

**PRELIMINARY DATA SHEET**

# SKY65152: 2.4-2.5 GHz WLAN Low Noise Amplifier

## Applications

- IEEE 802.11 b/g WLANs
- ISM band transmitters
- WCS fixed wireless
- Wireless access nodes

## Features

- EVM < 3% for P<sub>OUT</sub> > +27 dBm
- High gain = 31 dB
- Internal RF match with DC block and active bias circuits
- Internal on/off control circuit
- Single DC supply = +5 V
- Operating temperature = -40 °C to +85 °C
- Small, MCM (20-pin, 6 x 6 mm) Pb-free package (MSL3, 260 °C per JEDEC J-STD-020)

**NEW**

Skyworks offers lead (Pb)-free RoHS (Restriction of Hazardous Substances) compliant packaging.

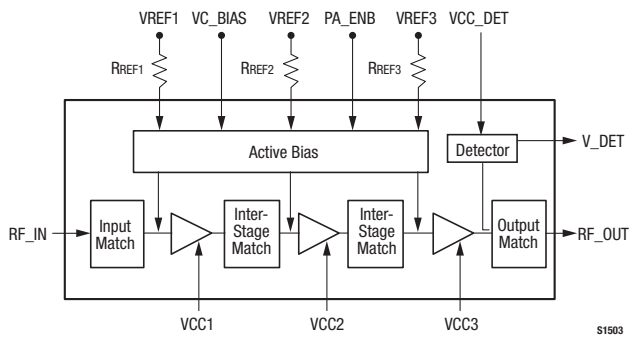

**Figure 1. SKY65152 Block Diagram**

## Description

The SKY65152 is a Microwave Monolithic Integrated Circuit (MMIC) Power Amplifier (PA) with superior output power, linearity, and efficiency. These features make the SKY65152 ideal for Wireless Local Area Network (WLAN) applications. The high linearity (low EVM) and high efficiency of this device makes it ideal for use in the transmit chain of WLAN access points or modems.

The SKY65152 is fabricated using Skyworks high reliability Aluminum (Al) Gallium Arsenide (GaAs) Heterojunction Bipolar Transistor (HBT) process, which allows for single supply operation while maintaining high efficiency and good linearity. The device is internally matched and mounted in a 20-pin, 6 x 6 mm Multi-Chip Module (MCM) Surface-Mounted Technology (SMT) package, which allows for a highly manufacturable low cost solution.

A functional block diagram is shown in Figure 1. The pin configuration and package are shown in Figure 2. Signal pin assignments and functional pin descriptions are provided in Table 1.

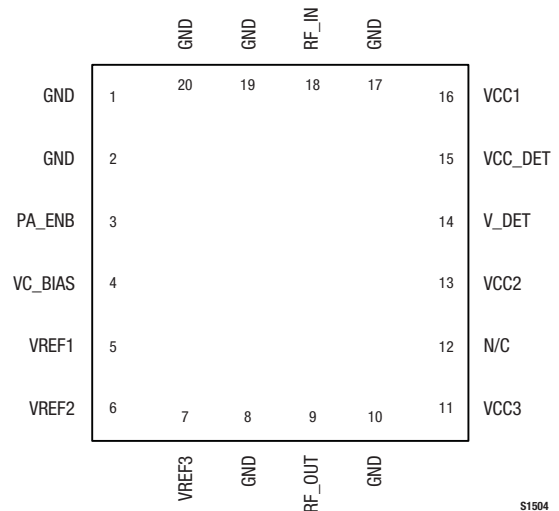

**Figure 2. SKY65152 Pinout – 20-Pin MCM (Top View)**

**Table 1. SKY65152 Signal Descriptions**

Pin #	Name	Description	Pin #	Name	Description
1	GND	Ground	11	VCC3	Stage 3 collector voltage
2	GND	Ground	12	N/C	No connection
3	PA_ENB	PA on/off control signal (on = +3 V to VCC; off = 0 to 0.5 V)	13	RF_OUT/BIAS	RF output/VCC bias
4	VC_BIAS	Bias voltage	14	VCC2	Stage 2 collector voltage
5	VREF1	Bias reference voltage 1	15	V_DET	Detector output signal
6	VREF2	Bias reference voltage 2	16	VCC_DET	Detector supply voltage
7	VREF3	Bias reference voltage 3	17	VCC1	Stage 1 collector voltage
8	GND	Ground	18	GND	Ground
9	RF_OUT	RF output	19	RF_IN	RF input
10	GND	Ground	20	GND	Ground

**Note:** The center attachment pad must have a low inductance and low thermal resistance connection to the printed circuit board ground plane.

### Functional Description

The SKY65152 is a three-stage, HBT InGaP device optimized for high linearity and power efficiency. It contains all of the needed RF matching and DC biasing circuits. An in-module active bias circuit is included within the device for all three amplifier stages, which provides excellent gain tracking over temperature and voltage variations.

The first, second, and output stages are independently supplied using the VCC1, VCC2, and VCC3 signals (pins 16, 13 and 11, respectively). The DC control voltage that sets the bias for all three stages is supplied by the VC\_BIAS signal (pin 4). The Evaluation Board includes shunt decoupling capacitors on these pins to suppress any possible bias affect on the RF signal at low frequencies.

The bias reference voltages for stages 1, 2, and 3 are supplied using the common lines VREF1, VREF2, and VREF3 (pins 5, 6, and 7, respectively). The maximum voltage for these pins is 4 V. Resistors R1, R2, and R3 on the Evaluation Board set the correct bias to these pins when attached to a 5 V power supply.

The SKY65152 includes an internal PA enable control pin (pin 3) for fast RF on/off control of < 0.5 μs. Zero volts turns off the PA while 3 to 5 V enables the PA. The device also provides an output power detector voltage, V\_DET, at pin 14. A bias voltage is

required to operate the detector. The detector supply voltage is provided through the VCC\_DET signal (pin 15). The maximum voltage for this pin is 4 V. Resistor R5 on the Evaluation Board sets the correct bias to this pin when attached to a 5 V power supply.

Pin 18 is the RF input and Pin 9 is the RF output. External DC blocking or RF matching is not required on the RF input and output. Grounding is through several ground pins and the package center ground.

These features make the device suitable for wideband digital applications where PA linearity and power consumption are of critical importance (e.g., WLANs). The device has been characterized with the highest specified data rates for 802.11b (11 Mbps) and 802.11g (54 Mbps). Under these stringent test conditions, the device exhibits excellent spectral purity and power efficiency.

### Electrical and Mechanical Specifications

The absolute maximum ratings of the SKY65152 are provided in Table 2. The recommended operating conditions are specified in Table 3 and electrical specifications are provided in Table 4.

**Table 2. SKY65152 Absolute Maximum Ratings (Note 1)**

Parameter	Symbol	Minimum	Typical	Maximum	Units
RF output power	P <sub>OUT</sub>		+28		dBm
Supply voltage (V <sub>CC</sub> , V <sub>C_BIAS</sub> , and PA_ENB) (Note 2)	V <sub>CC</sub>		5.5		V
Total supply current	I <sub>CC</sub>		850		mA
Reference voltage (Note 2)	V <sub>REF</sub>		4		V
Detector supply voltage (V <sub>CC_DET</sub> ) (Note 2)			4		V
Power dissipation	P <sub>D</sub>		1.1		W
Case temperature	T <sub>C</sub>	-40		+85	°C
Storage temperature	T <sub>STG</sub>	-55		+125	°C
Junction temperature	T <sub>J</sub>		+150		°C

**Note 1:** Exposure to maximum rating conditions for extended periods may reduce device reliability. There is no damage to device with only one parameter set at the limit and all other parameters set at or below their nominal value.

**Note 2:** Voltage levels measured at the pins of the package. The Evaluation Board supply voltage levels may be different. Refer to the Evaluation Board schematic diagram in this document.

**Table 3. SKY65152 Recommended Operating Conditions**

Parameter	Symbol	Minimum	Typical	Maximum	Units
RF input power	P <sub>IN</sub>			-3	dBm
Supply voltage (Note 1)	V <sub>CC</sub> , V <sub>C_BIAS</sub>		5		V
Reference voltage (Note 1)	V <sub>REF</sub>		2.5		V
Detector supply voltage (Note 1)	V <sub>CC_DET</sub>		3.6		V
Operating frequency	f	2412		2462	MHz
Case temperature	T <sub>C</sub>	-40	+25	+85	°C

**Note 1:** Voltage levels measured at the pins of the package. The Evaluation Board supply voltage levels may be different. Refer to the Evaluation Board schematic diagram in this document.

**Table 4. SKY65152 Electrical Specifications**

(VCC1 = VCC2 = VCC3 = VREF1 = VREF2 = VREF3 = VC\_BIAS = VCC\_DET = PA\_ENB = 5 V [Note 1], Characteristic Impedance [Z<sub>0</sub>] = 50 Ω, T<sub>c</sub> = 25 °C, Frequency = 2.442 GHz, Unless Otherwise Noted)

Parameter	Symbol	Test Condition	Min	Typical	Max	Units
<b>IEEE 802.11b Complimentary Code Keying Input Signal, Data Rate = 11 Mbps</b>						
Total supply current	I <sub>CC_TOTAL</sub>	Output power = P <sub>OUT</sub>		1070		mA
Output power (Note 2)	P <sub>OUT</sub>			+31		dBm
Power-added efficiency (Note 3)	PAE	Output power = P <sub>OUT</sub>		23		%
Ramp up/ramp down (Note 4)	TS	Small signal		<0.5		μs
<b>IEEE 802.11g Orthogonal Frequency Division Multiplexing Input Signal, Data Rate = 54 Mbps</b>						
Total supply current	I <sub>CC_TOTAL</sub>	Output power = P <sub>OUT</sub>		970		mA
Output power (Note 5)	P <sub>OUT</sub>			+30		dBm
Output power @ EVM = 2.5%	P <sub>OUT_EVM</sub>	Output power = P <sub>OUT</sub>		+27		dBm
Power-added efficiency (Note 3)	PAE	Output power = P <sub>OUT</sub>		20		%
<b>Continuous Wave Input Signal</b>						
Small signal gain	G	P <sub>IN</sub> = -25 dBm		31		dB
Gain flatness over band	P <sub>OUT</sub>	2.4 GHz to 2.5 GHz		±0.5		dB
Gain flatness over channel (16.25 MHz)	P <sub>OUT_EVM</sub>	Over any 16.25 MHz within band		±0.1		dB
Output power @ 1 dB compression	P1dB			+33		dBm
Output IP3	OIP3	P <sub>OUT/tone</sub> = +23 dBm, Δf = 5 MHz		+42		dBm
Quiescent current	I <sub>CCQ</sub>	No RF		465		mA
Noise Figure	NF			5		dB
Power-added efficiency	PAE	@ P1dB		33		%
Thermal resistance	Θ <sub>JC</sub>	Junction to case		20		°C/W
<b>Power Up/Down Control</b>						
Power up	PA_ENB on		3	5		V
Power down	PA_ENB off			0	0.5	V
Standby current	ISB	PA_ENB = 0 V		5		μA

**Note 1:** Voltage measured at Evaluation Board pins.

**Note 2:** Defined as the maximum power level for which the IEEE 802.11b transmit mask requirements are met.

**Note 3:** Measured at the specified average output RF power and modulation type.

**Note 4:** Ramp-up and ramp-down times are defined from the 10% to 90% power points.

**Note 5:** Defined as the maximum power level for which the IEEE 802.11g transmit mask requirements are met.

### Typical Performance Characteristics

(VCC1 = VCC2 = VCC3 = VREF1 = VREF2 = VREF3 = VC\_BIAS = VCC\_DET = PA\_ENB = 5 V [Note 1], Characteristic Impedance [Z<sub>0</sub>] = 50 Ω, T<sub>c</sub> = 25 °C, Frequency = 2.442 GHz, Unless Otherwise Noted)

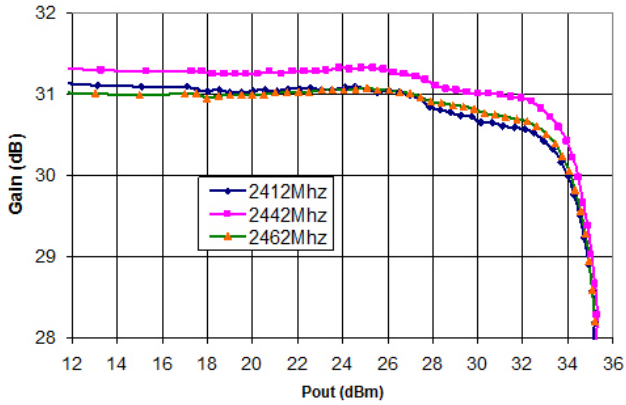

Figure 3. Gain vs Output Power Over Frequency

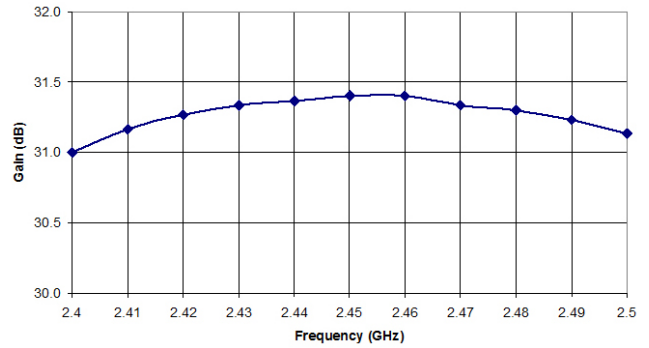

Figure 4. Small Signal Gain vs Frequency

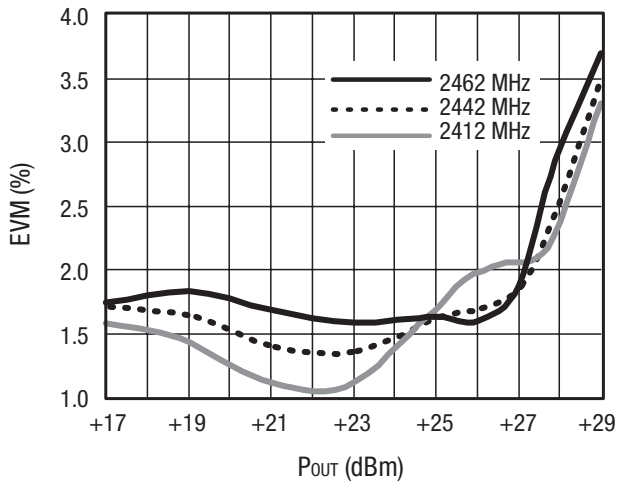

Figure 5. EVM vs Output Power Over Frequency

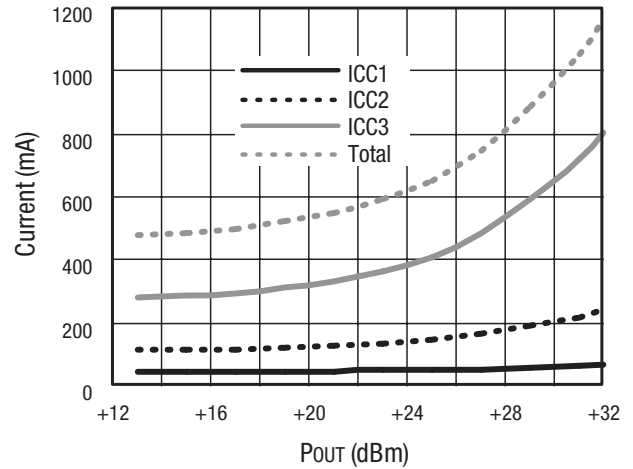
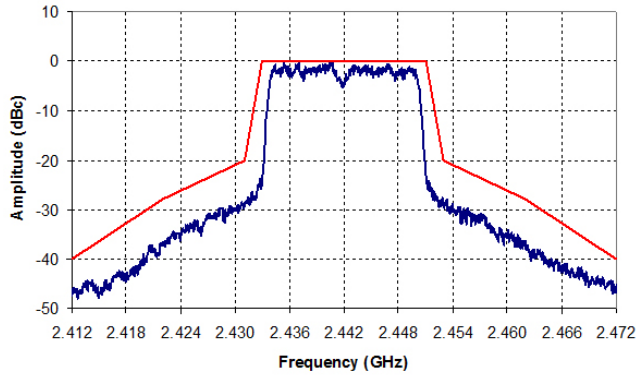
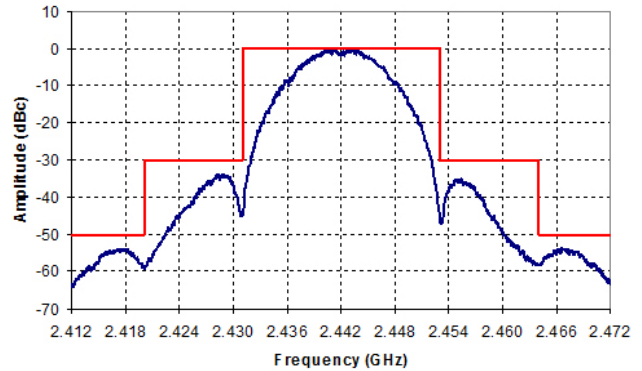

Figure 6. Current vs Output Power



**Figure 7. Spectral Response @ Pout = +30 dBm (802.11g, OFDM, 64 QAM @ 54 Mbps)**



**Figure 8. Spectral Response @ Pout = +31 dBm (802.11b, CCK @ 11 Mbps)**

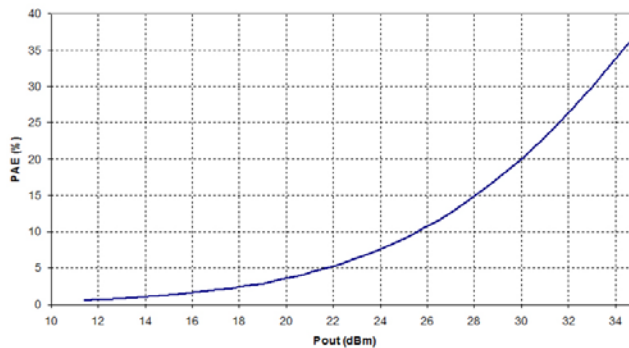

**Figure 9. PAE vs Output Power**

### Evaluation Board Description

The SKY65152 Evaluation Board is used to test the performance of the SKY65152 LNA. An Evaluation Board schematic diagram is provided in Figure 10. An assembly drawing for the Evaluation Board is shown in Figure 11.

An Evaluation Board layer detail drawing is shown in Figure 12. Layer detail physical characteristics are noted in Figure 13. Table 5 provides the Bill of Materials (BOM) list for Evaluation Board components.

### Circuit Design Considerations

The following design considerations are general in nature and must be followed regardless of final use or configuration:

1. Paths to ground should be made as short as possible.
2. The ground pad of the SKY65152 has special electrical and thermal grounding requirements. This pad is the main thermal conduit for heat dissipation. Since the circuit board acts as the heat sink, it must shunt as much heat as possible from the device. Therefore, design the connection to the ground

pad to dissipate the maximum wattage produced by the circuit board. Multiple vias to the grounding layer are required.

3. Bypass capacitors should be used on the DC supply lines. An RF inductor is required on the VCC supply line to block RF signals from the DC supply. Refer to the schematic drawing in Figure 10 for further details.
4. The RF lines should be well separated from each other with solid ground in between traces to maximize input-to-output isolation.

**NOTE:** A poor connection between the slug and ground increases junction temperature ( $T_J$ ), which reduces the lifetime of the device.

### Evaluation Board Test Procedure

- Step 1: Connect a +5 V supply to the VCC1, VCC2, VCC3, VREF1, VREF2, VREF3, VC\_BIAS, VCC\_DET, and PA\_ENB pins. If available, enable the current limiting function of the power supply to 850 mA.

- Step 2: If desired, connect a voltage meter to the V\_DET pin.
- Step 3: Connect a signal generator to the RF signal input port. Set it to the desired RF frequency at a power level of -15 dBm or less to the Evaluation Board. **DO NOT** enable the RF signal.
- Step 4: Connect a spectrum analyzer to the RF signal output port.
- Step 5: Enable the power supply.
- Step 6: Enable the RF signal.
- Step 7: Take measurements.

**CAUTION:** If the input signal exceeds the rated power, the SKY65152 Evaluation Board can be permanently damaged.

**NOTE:** It is important to adjust the VCC voltage source so that +5 V is measured at the board. The high collector currents will drop the collector voltage significantly if long leads are used. Adjust the bias voltage to compensate.

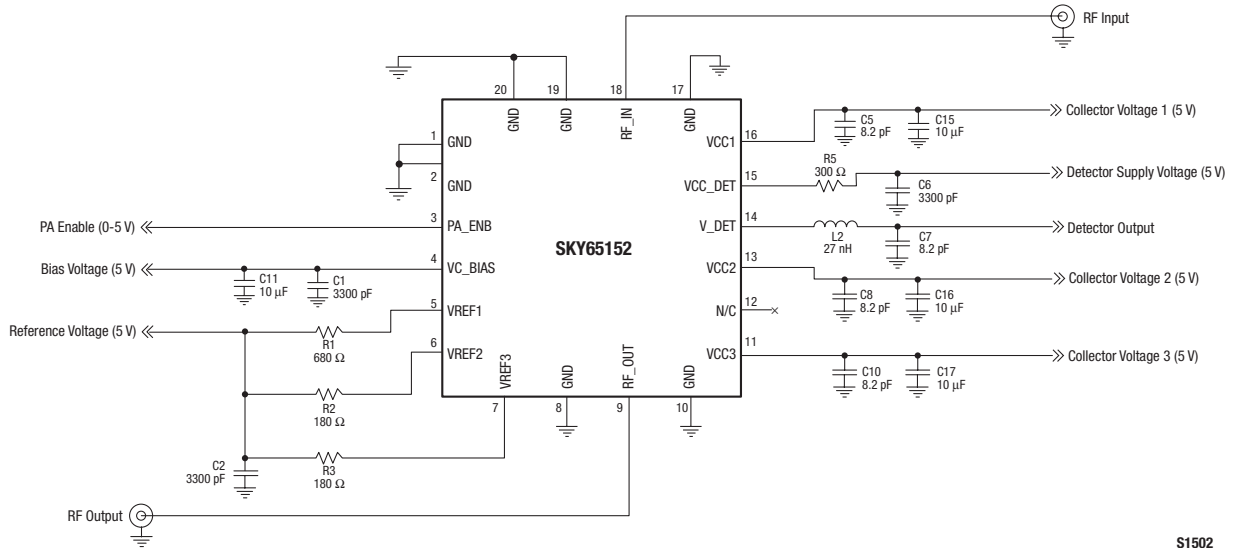

S1502

Figure 10. SKY65152 Evaluation Board Schematic

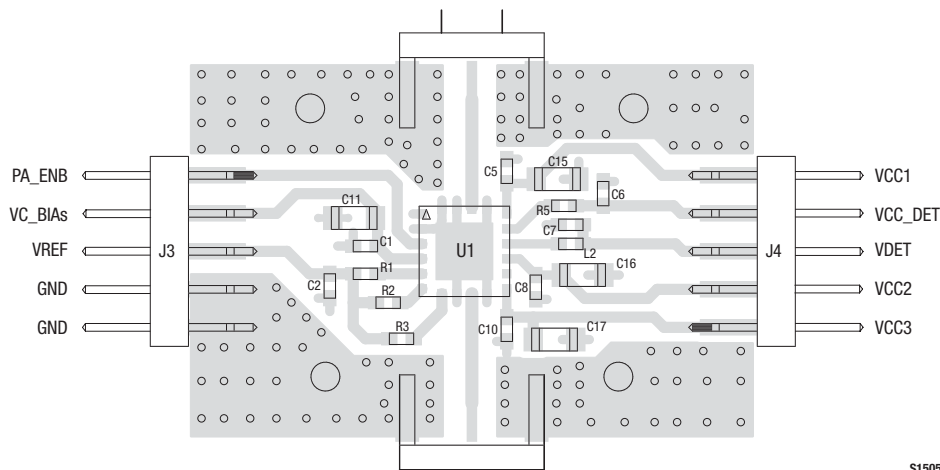

S1505

Figure 11. SKY65152 Evaluation Board Assembly Diagram

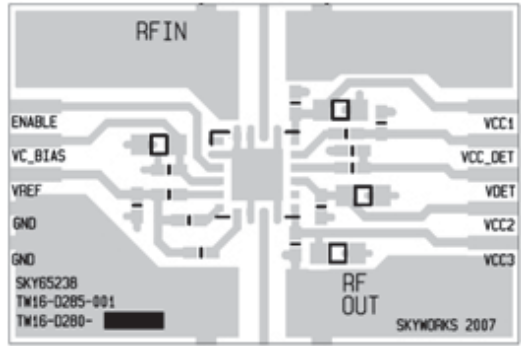

Layer 1: Silk Screen

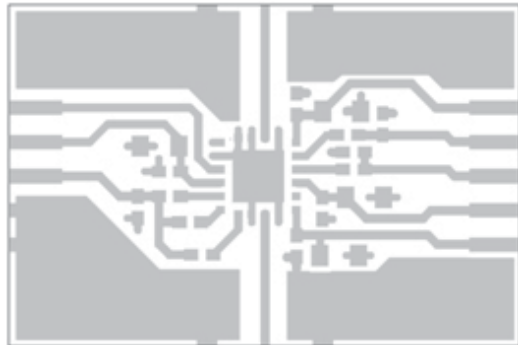

Layer 1: Top Metal

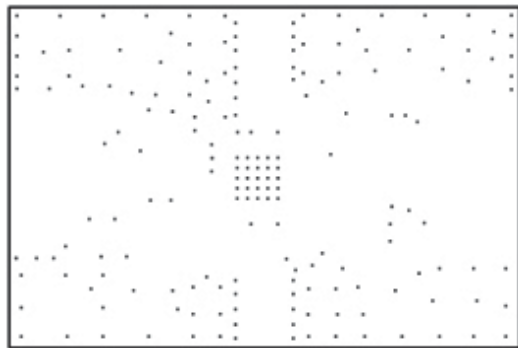

Layer 2 and 3: Ground

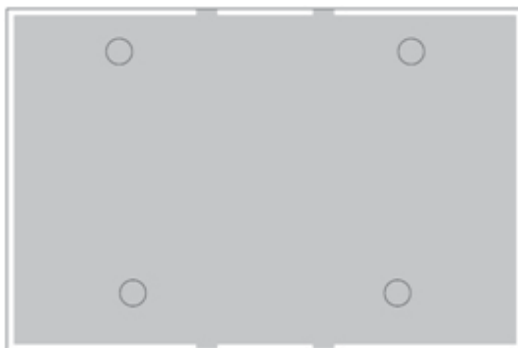

Layer 4: Backside Ground

S1508

Figure 12. SKY65152 Evaluation Board Layer Detail



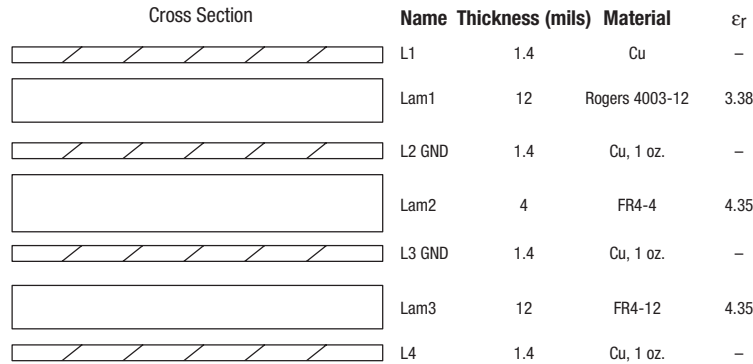

Figure 13. Layer Detail Physical Characteristics

Table 5. SKY65152 Evaluation Board Bill of Materials

Component	Value	Size	Product #	Manufacturer	Manufacturer's Part #	Characteristics
C1, C2, C6	3300 pF	0603	5404R28-015	Murata	GRM188R71H332KD01J	X7R, 50 V, $\pm 10\%$
C5, C7, C8, C10	8.2 pF	0603	5404R98-010	Murata	GRM1885C1H8R2CZ01D	C0G, 50 V, $\pm 0.25$ pF
C11, C15, C16, C17	10 $\mu$ F	0603	5404R91-005	TDK	C3216X5R0J106KT	X5R, 6 V, $\pm 10\%$
L2	27 nH	0603	5332R34-030	Taiyo-Yuden	HK160827NJ-T	$\pm 5\%$ , SRF 2200 MHz
R1	680 $\Omega$	0603	5424R20-045	Rohm	MCR03EZHUJ680	50 V, 0.063 W, $\pm 5\%$
R2, R3	180 $\Omega$	0603	5424R20-031	Rohm	MCR03EZHUJ180	50 V, 0.063 W, $\pm 5\%$
R5	300 $\Omega$	0603	5424R20-036	Rohm	MCR03EZHUJ300	50 V, 0.063 W, $\pm 5\%$

**Application Circuit Notes**

**Center Ground.** It is extremely important to sufficiently ground the bottom ground pad of the device for both thermal and stability reasons. Multiple small vias are acceptable and will work well under the device if solder migration is an issue.

**GND (pins 1, 2, 8, 10, 17, 19, and 20).** Attach all ground pins to the RF ground plane with the largest diameter and lowest inductance via that the layout allows. Multiple small vias are acceptable and will work well under the device if solder migration is an issue.

**PA\_ENB (pin 3).** Internal PA enable control pin for fast on/off control < 0.5  $\mu$ s (on = +3 V to VCC; off = 0 to 0.5 V).

**VC\_BIAS (pin 4).** The bias supply voltage for stages 1 and 2, typically set to +5 V.

**VREF1 (pin 5).** Bias reference voltage for amplifier stage 1. This signal should be operated over the same voltage range as VCC with a nominal voltage of +5 V.

**VREF2 (pin 6).** Bias reference voltage for amplifier stage 2. This signal should be operated over the same voltage range as VCC with a nominal voltage of +5 V.

**VREF3 (pin 7).** Bias reference voltage for amplifier stage 3. This signal should be operated over the same voltage range as VCC with a nominal voltage of +5 V.

**RF\_OUT (pin 9).** Amplifier RF output pin ( $Z_0 = 50 \Omega$ ). The module includes an onboard internal DC blocking capacitor. All impedance matching is provided internal to the module.

**VCC3 (pin 11).** Supply voltage for the output (final) stage collector bias (typically +5 V). To bypass VCC3, capacitors C10 and C17 (see Figure 10) should be placed in the approximate location shown on the Evaluation Board, although exact placement is not critical.

**N/C (pin 12).** This pin is open and may or may not be connected to ground.

**VCC2 (pin 13).** Supply voltage for the second stage collector bias (typically +5 V). To bypass VCC2, capacitors C8 and C16 (see Figure 10) should be placed in the approximate location shown on the Evaluation Board, although exact placement is not critical.

**V\_DET (pin 14).** The output power detector voltage signal. The detector load and settling time constant are set external to the device. Inductor L2 and capacitor C7 (see Figure 10) are set to yield a settling time of < 0.5  $\mu$ s.

**VCC\_DET (pin 15).** The power detector supply voltage signal. Resistor R5 and capacitor C5 (see Figure 10) are used for proper bias and bypassing of this pin, provided pin 15 is connected to the PA\_ENB supply (pin 3). The benefit of this is that the current draw consumed by the detector will not be wasted with the device in the off state.

**VCC1 (pin 16).** Supply voltage for the first stage collector bias (typically +5 V). To bypass VCC1, capacitors C5 and C15 (see Figure 10) should be placed in the approximate location shown on the Evaluation Board, although exact placement is not critical.

**RF\_IN (pin 18).** Amplifier RF input pin ( $Z_0 = 50 \Omega$ ). The module includes an onboard internal DC blocking capacitor. All impedance matching is provided internal to the module.

### Package Dimensions

The PCB layout footprint for the SKY65152 is shown in Figure 14. Typical case markings are shown in Figure 15. Package dimensions for the 20-pin MCM are shown in Figure 16, and tape and reel dimensions are provided in Figure 17.

### Package and Handling Information

Since the device package is sensitive to moisture absorption, it is baked and vacuum packed before shipping. Instructions on the shipping container label regarding exposure to moisture after the

container seal is broken must be followed. Otherwise, problems related to moisture absorption may occur when the part is subjected to high temperature during solder assembly.

THE SKY65152 is rated to Moisture Sensitivity Level 3 (MSL3) at 260 °C. It can be used for lead or lead-free soldering.

Care must be taken when attaching this product, whether it is done manually or in a production solder reflow environment. Production quantities of this product are shipped in a standard tape and reel format. For packaging details, refer to the Skyworks Application Note, *Tape and Reel Information – RF Modules*, document number 101568.

### Electrostatic Discharge (ESD) Sensitivity

The SKY65152 is a static-sensitive electronic device. Do not operate or store near strong electrostatic fields. Take proper ESD precautions.

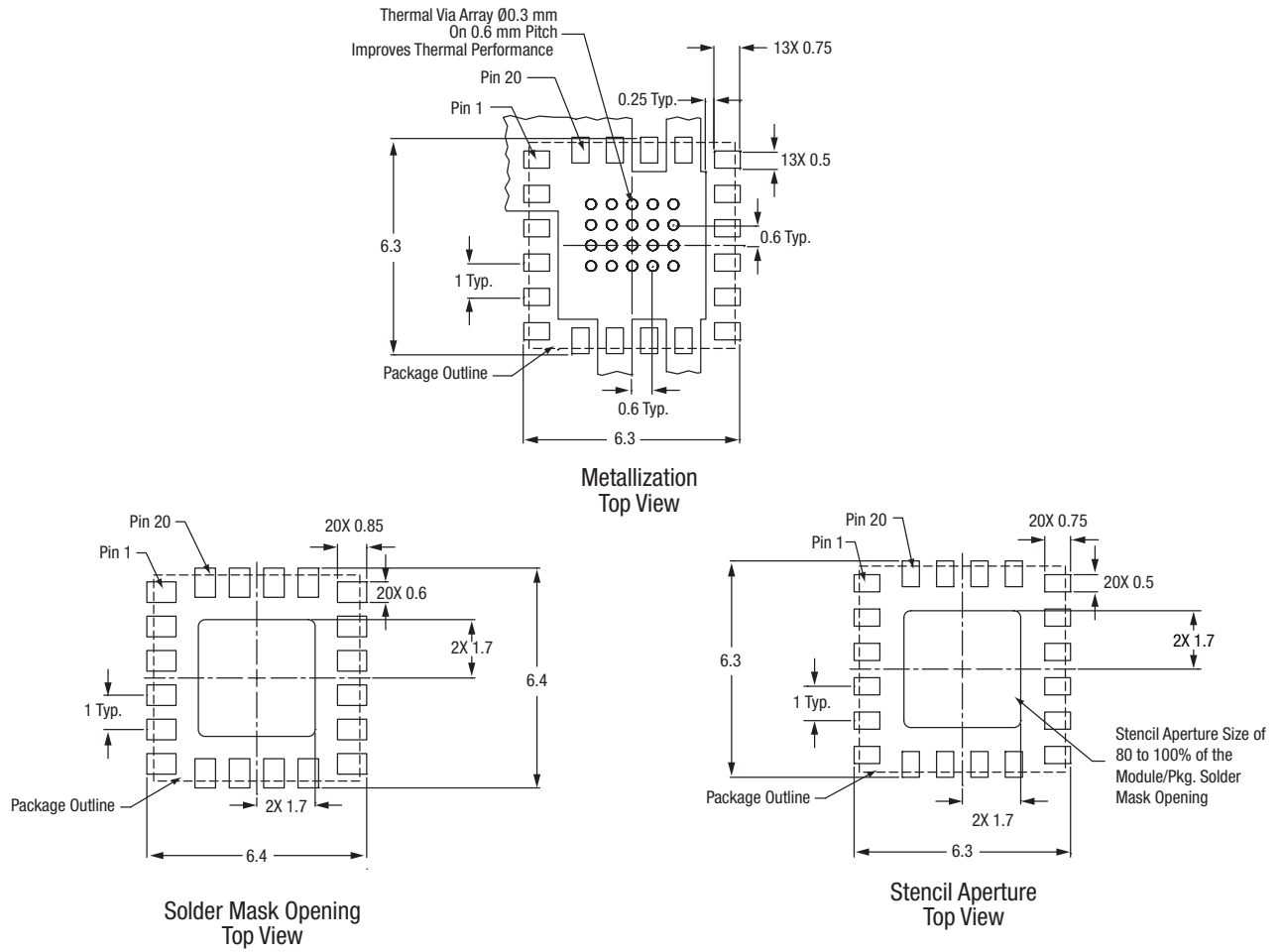

All dimensions are in millimeters

S1507

Figure 14. SKY65152 PCB Layout Footprint

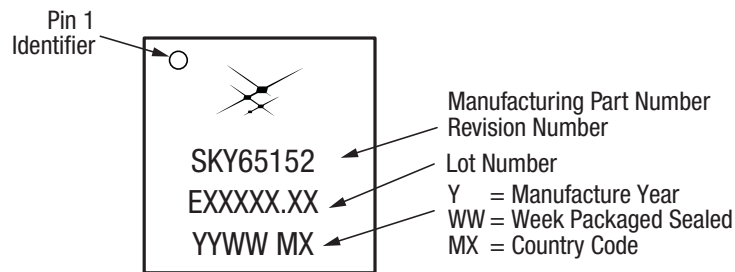
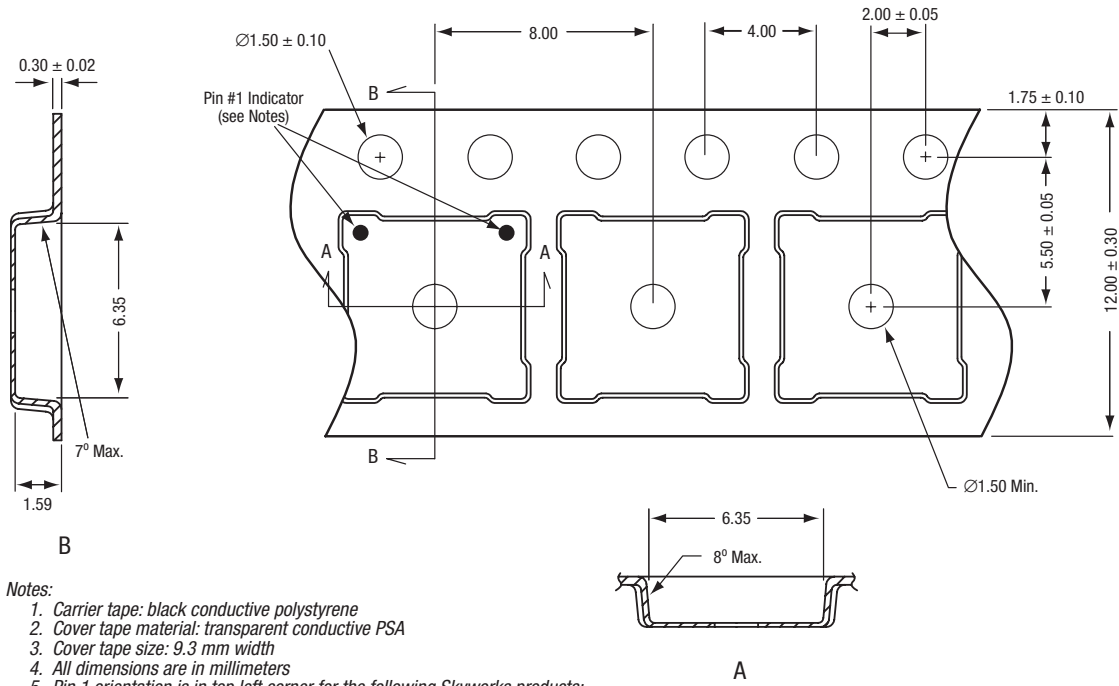

Figure 15. SKY65152 Typical Case Markings





S1183

Figure 17. SKY65152 20-Pin MCM Tape and Reel Dimensions

### Ordering Information

Model Name	Manufacturing Part Number	Evaluation Kit Part Number
SKY65152 WLAN Power Amplifier	SKY65152-xx (Pb-free package)	TW16-D280-031

Copyright © 2009 Skyworks Solutions, Inc. All Rights Reserved.

Information in this document is provided in connection with Skyworks Solutions, Inc. ("Skyworks") products or services. These materials, including the information contained herein, are provided by Skyworks as a service to its customers and may be used for informational purposes only by the customer. Skyworks assumes no responsibility for errors or omissions in these materials or the information contained herein. Skyworks may change its documentation, products, services, specifications or product descriptions at any time, without notice. Skyworks makes no commitment to update the materials or information and shall have no responsibility whatsoever for conflicts, incompatibilities, or other difficulties arising from any future changes.

No license, whether express, implied, by estoppel or otherwise, is granted to any intellectual property rights by this document. Skyworks assumes no liability for any materials, products or information provided hereunder, including the sale, distribution, reproduction or use of Skyworks products, information or materials, except as may be provided in Skyworks Terms and Conditions of Sale.

THE MATERIALS, PRODUCTS AND INFORMATION ARE PROVIDED "AS IS" WITHOUT WARRANTY OF ANY KIND, WHETHER EXPRESS, IMPLIED, STATUTORY, OR OTHERWISE, INCLUDING FITNESS FOR A PARTICULAR PURPOSE OR USE, MERCHANTABILITY, PERFORMANCE, QUALITY OR NON-INFRINGEMENT OF ANY INTELLECTUAL PROPERTY RIGHT; ALL SUCH WARRANTIES ARE HEREBY EXPRESSLY DISCLAIMED. SKYWORKS DOES NOT WARRANT THE ACCURACY OR COMPLETENESS OF THE INFORMATION, TEXT, GRAPHICS OR OTHER ITEMS CONTAINED WITHIN THESE MATERIALS. SKYWORKS SHALL NOT BE LIABLE FOR ANY DAMAGES, INCLUDING BUT NOT LIMITED TO ANY SPECIAL, INDIRECT, INCIDENTAL, STATUTORY, OR CONSEQUENTIAL DAMAGES, INCLUDING WITHOUT LIMITATION, LOST REVENUES OR LOST PROFITS THAT MAY RESULT FROM THE USE OF THE MATERIALS OR INFORMATION, WHETHER OR NOT THE RECIPIENT OF MATERIALS HAS BEEN ADVISED OF THE POSSIBILITY OF SUCH DAMAGE.

Skyworks products are not intended for use in medical, lifesaving or life-sustaining applications, or other equipment in which the failure of the Skyworks products could lead to personal injury, death, physical or environmental damage. Skyworks customers using or selling Skyworks products for use in such applications do so at their own risk and agree to fully indemnify Skyworks for any damages resulting from such improper use or sale.

Customers are responsible for their products and applications using Skyworks products, which may deviate from published specifications as a result of design defects, errors, or operation of products outside of published parameters or design specifications. Customers should include design and operating safeguards to minimize these and other risks. Skyworks assumes no liability for applications assistance, customer product design, or damage to any equipment resulting from the use of Skyworks products outside of stated published specifications or parameters.

Skyworks, the Skyworks symbol, and "Breakthrough Simplicity" are trademarks or registered trademarks of Skyworks Solutions, Inc., in the United States and other countries. Third-party brands and names are for identification purposes only, and are the property of their respective owners. Additional information, including relevant terms and conditions, posted at [www.skyworksinc.com](http://www.skyworksinc.com), are incorporated by reference.