

## FEATURES

- 3.3V, 5.0V, 12V, and Adjustable Output Versions
- Adjustable Version Output Voltage Range, 1.2 to 37V  
+/- 4%. Maximum Over Line and Load Conditions
- Guaranteed 3.0A Output Current
- Wide Input Voltage Range
- Requires Only 4 External Components
- 150kHz Fixed Frequency Internal Oscillator
- TTL Shutdown Capability, Low Power Standby Mode
- High Efficiency
- Uses Readily Available Standard Inductors
- Thermal Shutdown and Current Limit Protection
- Moisture Sensitivity Level 3

## Applications

- Simple High-Efficiency Step-Down(Buck) Regulator
- Efficient Pre-Regulator for Linear Regulators
- On-Card Switching Regulators
- Positive to Negative Converter(Buck-Boost)
- Negative Step-Up Converters
- Power Supply for Battery Chargers

## DESCRIPTION

The LM2596 series of regulators are monolithic integrated circuits ideally suited for easy and convenient design of a step-down switching regulator(buck converter).

All circuits of this series are capable of driving a 3.0A load with excellent line and load regulation. These devices are available in fixed output voltages of 3.3V, 5.0V,12V, and an adjustable output version.

These regulators were designed to minimize the number of external components to simplify the power supply design. Standard series of inductors optimized for use with the LM2596 are offered by several different inductor manufacturers.

Since the LM2596 converter is a switch-mode power supply, its efficiency is significantly higher in comparison with popular three-terminal linear regulators, especially with higher input voltages.

In many cases, the power dissipated is so low that no heatsink is required or its size could be reduced dramatically. A standard series of inductors optimized for use with the TJ2596 are available from several different manufacturers. This feature greatly simplifies the design of switch-mode power supplies. The LM2596 features include a guaranteed +/- 4% tolerance on output voltage within specified input voltages and output load conditions, and +/-15% on the oscillator frequency (+/- 2% over 0°C to 125°C).

External shutdown is included, featuring 80µA (typical) standby current. Self protection features include a two stage frequency reducing current limit for output switch and an over temperature shutdown for complete protection under fault conditions.

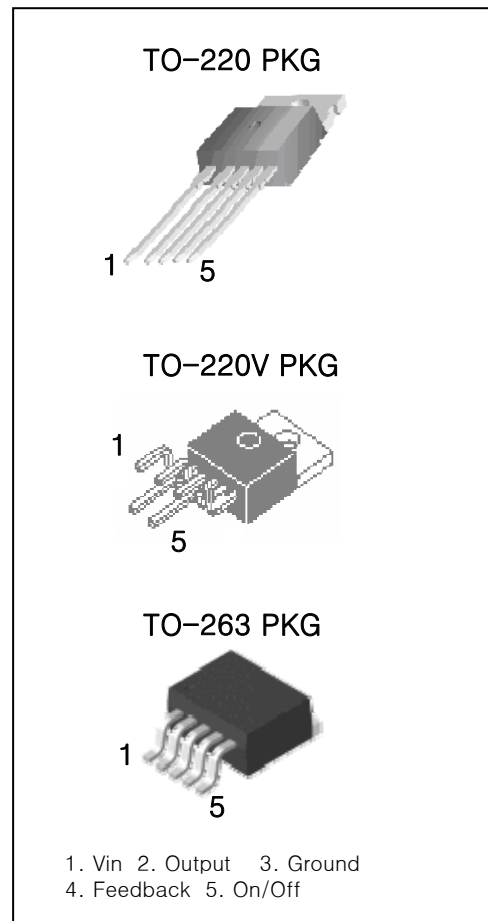

## ORDERING INFORMATION

Device	Marking	Package
LM2596T-X.X	LM2596-X.X	TO-220
LM2596TV-X.X	LM2596-X.X	TO-220V
LM2596R	LM2596-X.X	TO-263

Typical Application (Fixed Output Voltage Versions)

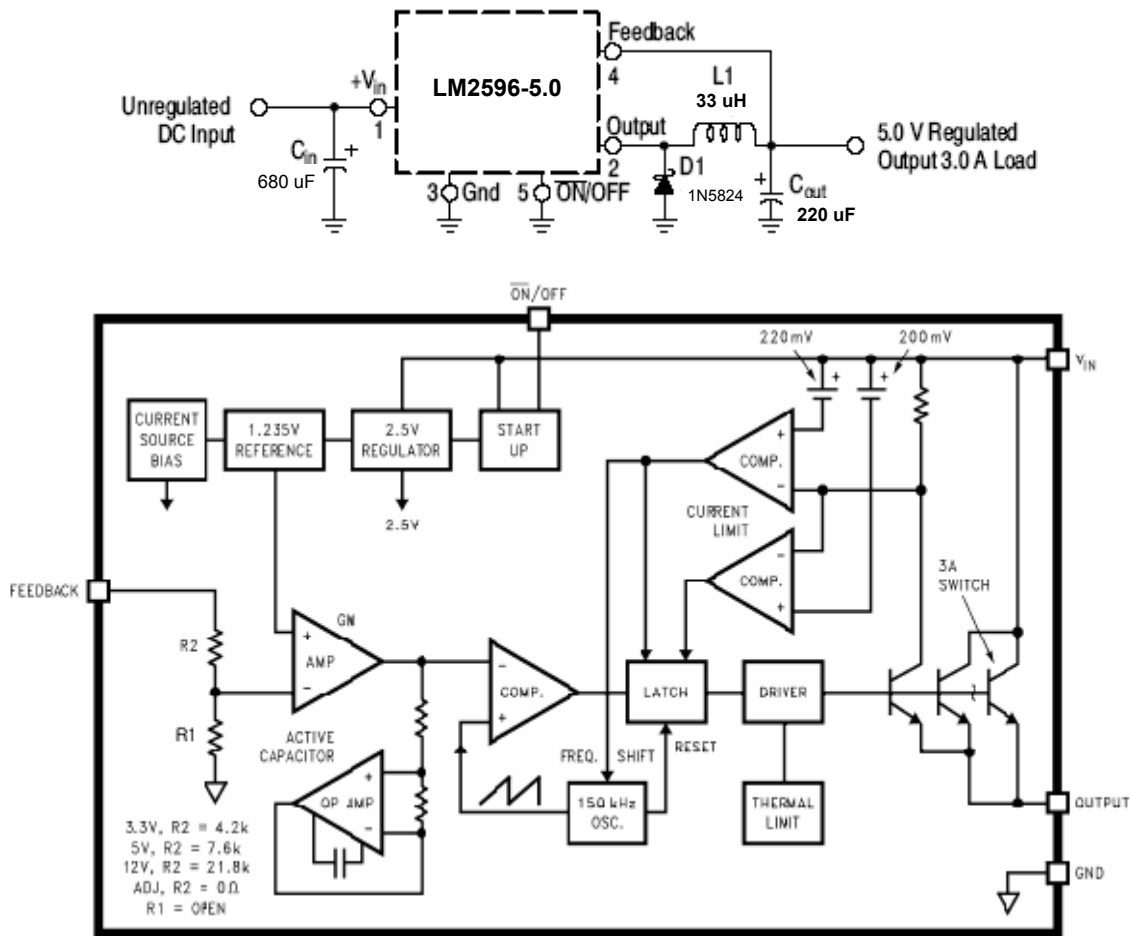

Figure 1. Block Diagram and Typical Application

**ABSOLUTE MAXIMUM RATINGS**

(Absolute Maximum Ratings indicate limits beyond which damage to the device may occur.)

Rating	Symbol	Value	Unit
Maximum Supply Voltage	V <sub>in</sub>	45	V
On/Off Pin Input Voltage	-	-0.3V ≤ V ≤ +V <sub>in</sub>	V
Output Voltage to Ground (Steady-State)	-	- 1.0	V
Power Dissipation			
TO-220 5Lead	P <sub>D</sub>	Internally Limited	W
Thermal Resistance, Junction to Ambient	P <sub>eJA</sub>	65	°C/W
Thermal Resistance, Junction to Case	P <sub>eJC</sub>	5.0	°C/W
TO-263 5Lead	P <sub>D</sub>	Internally Limited	W
Thermal Resistance, Junction to Ambient	P <sub>eJA</sub>	70	°C/W
Thermal Resistance, Junction to Case	P <sub>eJC</sub>	5.0	°C/W
Storage Temperature Range	T <sub>stg</sub>	-60 to +150	°C
Minimum ESD Rating(Human Body Model : C=100 pF, R=1.5kΩ)	-	2.0	kV
Lead Temperature (Soldering,10seconds)	-	260	°C
Maximum Junction Temperature	T <sub>J</sub>	150	°C

**OPERATING RATINGS** (Operating Ratings indicate conditions for which the device is intended to be functional, but do not guarantee specific performance limits. For guaranteed specifications and test conditions, see the Electrical Characteristics.)

Rating	Symbol	Value	Unit
Operating Junction Temperature Range	T <sub>J</sub>	-40 to +125	°C
Supply Voltage	V <sub>in</sub>	40	V

#### ELECTRICAL CHARACTERISTICS / SYSTEM PARAMETERS ([Note 1] Test Circuit Figure 2)

(Unless otherwise specified, V<sub>in</sub> = 12V for the 3.3V, 5.0V, and Adjustable version, V<sub>in</sub> = 25V for the 12V version. I<sub>LOAD</sub> = 500 mA. For typical values T<sub>J</sub> = 25°C, for min/max values T<sub>J</sub> is the operating junction temperature range that applies [Note 2], unless otherwise noted.)

Characteristics	Symbol	Min	TYP	Max	Unit
<b>LM2596-3.3V ([Note 1] Test Circuit Figure 2)</b>					
Output Voltage (V <sub>in</sub> = 12V, I <sub>LOAD</sub> =0.5A, T <sub>J</sub> =25°C)	V <sub>out</sub>	3.234	3.3	3.366	V
Output Voltage (6.0V ≤ V <sub>in</sub> ≤ 40V, 0.5A ≤ I <sub>LOAD</sub> ≤ 3.0A T <sub>J</sub> =25°C T <sub>J</sub> = -40°C ~ +125°C)	V <sub>out</sub>	3.168 3.135	3.3 -	3.432 3.465	V
Efficiency (V <sub>in</sub> =12V, I <sub>LOAD</sub> =3.0A)	η	-	73	-	%

<b>LM2596-5.0V ([Note 1] Test Circuit Figure 2)</b>					
Output Voltage (V <sub>in</sub> = 12V, I <sub>LOAD</sub> =0.5A, T <sub>J</sub> =25°C)	V <sub>out</sub>	4.9	5.0	5.1	V
Output Voltage (8.0V ≤ V <sub>in</sub> ≤ 40V, 0.5A ≤ I <sub>LOAD</sub> ≤ 3.0A T <sub>J</sub> =25°C T <sub>J</sub> = -40°C ~ +125°C)	V <sub>out</sub>	4.8 4.75	5.0 -	5.2 5.25	V
Efficiency (V <sub>in</sub> =12V, I <sub>LOAD</sub> =3.0A)	η	-	80	-	%

<b>LM2596-12V ([Note 1] Test Circuit Figure 2)</b>					
Output Voltage (V <sub>in</sub> = 25V, I <sub>LOAD</sub> =0.5A, T <sub>J</sub> =25°C)	V <sub>out</sub>	11.76	12	12.24	V
Output Voltage (15V ≤ V <sub>in</sub> ≤ 40V, 0.5A ≤ I <sub>LOAD</sub> ≤ 3.0A T <sub>J</sub> =25°C T <sub>J</sub> = -40°C ~ +125°C)	V <sub>out</sub>	11.52 11.4	12 -	12.48 12.6	V
Efficiency (V <sub>in</sub> =12V, I <sub>LOAD</sub> =3.0A)	η	-	90	-	%

<b>LM2596-ADJ ([Note 1] Test Circuit Figure 2)</b>					
Feedback Voltage (V <sub>in</sub> =12V, I <sub>LOAD</sub> =0.5A, T <sub>J</sub> =25°C)	V <sub>out</sub>	1.217	1.23	1.243	V
Feedback Voltage (8.0V ≤ V <sub>in</sub> ≤ 40V, 0.5A ≤ I <sub>LOAD</sub> ≤ 3.0A, V <sub>out</sub> =5.0V) T <sub>J</sub> =25°C T <sub>J</sub> = -40°C ~ +125°C)	V <sub>out</sub>	1.193 1.18	1.23 -	1.267 1.28	V
Efficiency (V <sub>in</sub> =12V, I <sub>LOAD</sub> =3.0A, V <sub>out</sub> =5.0V)	η	-	73	-	%

#### ELECTRICAL CHARACTERISTICS / Device Parameters

(Unless otherwise specified,  $V_{in} = 12V$  for the 3.3V, 5.0V, and Adjustable version,  $V_{in} = 25V$  for the 12V version.  $I_{Load} = 500\text{ mA}$ . For typical values  $T_J = 25^\circ\text{C}$ , for min/max values  $T_J$  is the operating junction temperature range that applies [Note 2], unless otherwise noted.)

Characteristics	Symbol	Min	TYP	Max	Unit
<b>All Output Voltage Versions</b>					
Feedback Bias Current ( $V_{out}=5.0V$ [Adjustable Version Only]) $T_J=25^\circ\text{C}$ $T_J= 0 \sim +125^\circ\text{C}$	$I_b$	11.52 11.4	12 –	12.48 12.6	nA
Oscillator Frequency [Note 3] $T_J=25^\circ\text{C}$ $T_J= 0 \sim +125^\circ\text{C}$	$F_{osc}$	127 110	150 –	173 173	kHz
Saturation Voltage ( $I_{out}=3.0A$ [note 4]) $T_J=25^\circ\text{C}$ $T_J= 0 \sim +125^\circ\text{C}$	$V_{sat}$	– –	1.16 –	1.4 1.5	V
Max Duty Cycle ("0") [Note 5]	DC	–	100	–	%
Current Limit (Peak Current [Note 3 and 4]) $T_J=25^\circ\text{C}$ $T_J= 0 \sim +125^\circ\text{C}$	$I_{CL}$	3.6 3.4	4.5 –	6.9 7.5	A
Output Leakage Current [Note 6 and 7], $T_J=25^\circ\text{C}$ Output = 0V Output = -1.0V	$I_L$	– –	– 2	50 30	mA
Quiescent Current [Note 6] $T_J=25^\circ\text{C}$ $T_J= 0 \sim +125^\circ\text{C}$	$I_Q$	– –	5 –	– 10	mA
Standby Quiescent Current (ON/OFF Pin = 5.0V ("off")) $T_J=25^\circ\text{C}$ $T_J= 0 \sim +125^\circ\text{C}$	$I_{STBY}$	– –	80 –	200 250	$\mu\text{A}$
ON/OFF Pin Logic Input Level (Test circuit Figure 2) $V_{out}=0V$ $T_J=25^\circ\text{C}$ $T_J= 0 \sim +125^\circ\text{C}$ $V_{out}=\text{Nominal Output Voltage}$ $T_J=25^\circ\text{C}$ $T_J= 0 \sim +125^\circ\text{C}$	$V_{IH}$   $V_{IL}$	2.0 2.0 – –	1.3 – 1.3 –	– – 0.6 0.6	V
ON/OFF Pin Input Current (Test Circuit Figure 2) $V_{LOGIC} = 2.5V$ (Regulator OFF) $V_{LOGIC} = 0.5V$ (Regulator ON)	$I_{IH}$ $I_{IL}$	– –	5 0.02	15 5.0	$\mu\text{A}$

- External components such as the catch diode, inductor, input and output capacitors can affect switching regulator system performance. When the LM2596 is used as shown in the Figure 1 test circuit, system performance will be as shown in system parameters section .
- Tested junction temperature range for the TJ2596 :  $T_{LOW} = -40^\circ\text{C}$   $T_{HIGH} = +125^\circ\text{C}$
- The oscillator frequency reduces to approximately 18kHz in the event of an output short or an overload which causes the regulated output voltage to drop approximately 40% from the nominal output voltage. This self protection feature lowers the average dissipation of the IC by lowering the minimum duty cycle from 5% down to approximately 2%.
- Output (Pin 2) sourcing current. No diode, inductor or capacitor connected to output pin.
- Feedback (Pin 4) removed from output and connected to 0 V.
- Feedback (Pin 4) removed from output and connected to +12V for the Adjustable, 3.3V, and 5.0V versions, and +25 V for the 12V versions, to force the output transistor "off".C195
- $V_{in} = 40\text{ V}$ .

## TYPICAL PERFORMANCE CHARACTERISTICS (Circuit of Figure 2)

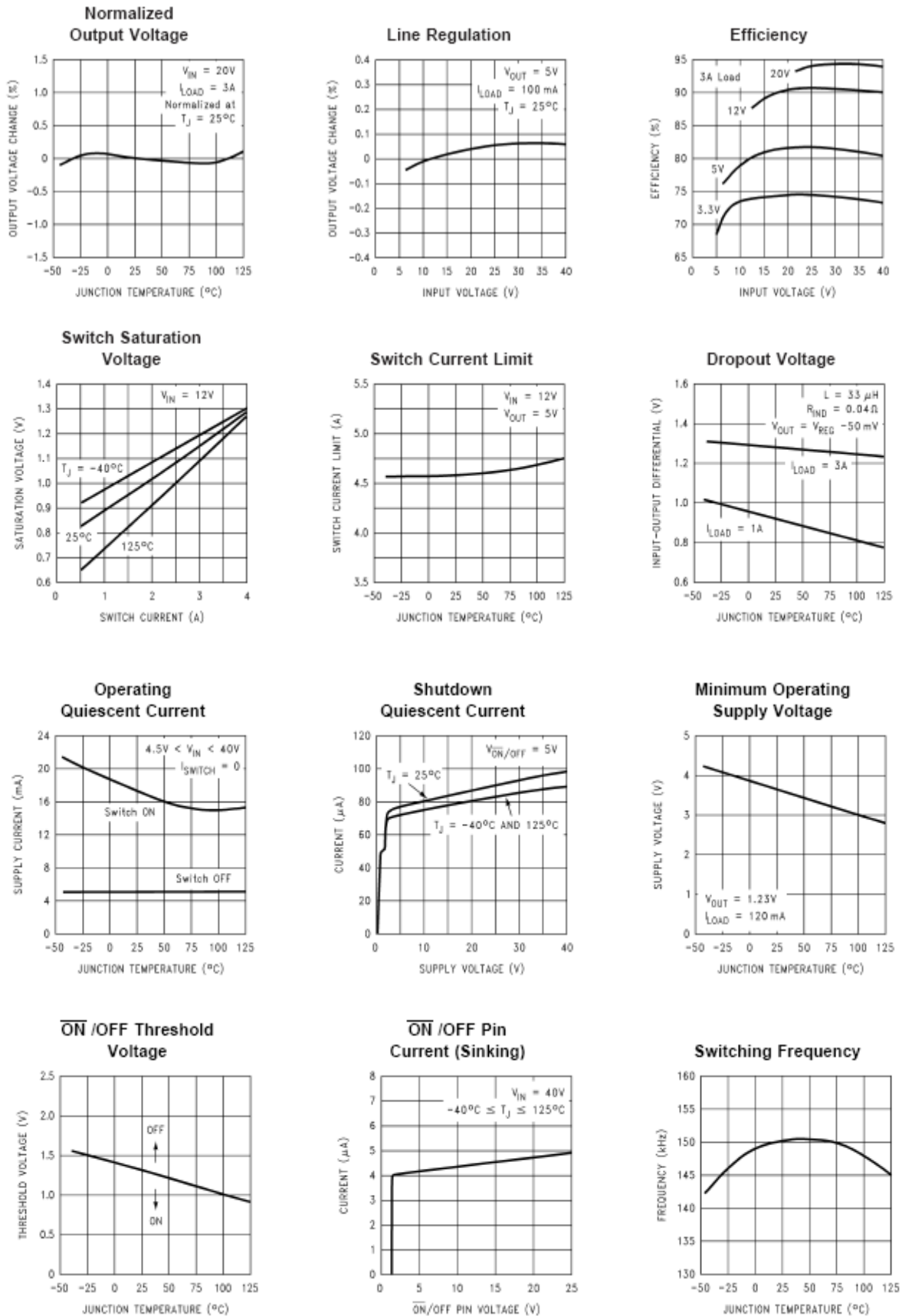

TYPICAL PERFORMANCE CHARACTERISTICS (Circuit of Figure 2)

Feedback Pin Bias Current

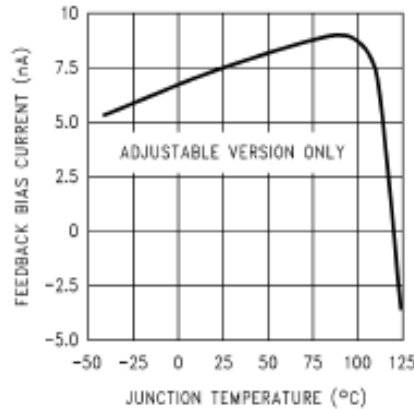

Continuous Mode Switching Waveforms

$V_{IN} = 20V, V_{OUT} = 5V, I_{LOAD} = 2A$   
 $L = 32 \mu H, C_{OUT} = 220 \mu F, C_{OUT} ESR = 50 m\Omega$

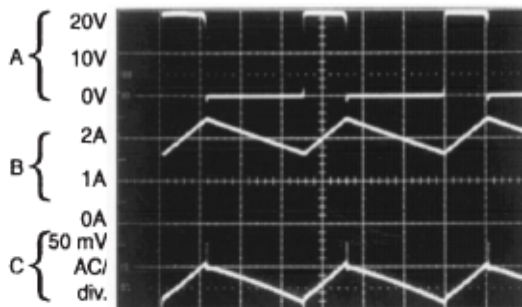

Horizontal Time Base: 2  $\mu s/div.$

A: Output Pin Voltage, 10V/div.  
 B: Inductor Current 1A/div.  
 C: Output Ripple Voltage, 50 mV/div.

Discontinuous Mode Switching Waveforms

$V_{IN} = 20V, V_{OUT} = 5V, I_{LOAD} = 500 mA$   
 $L = 10 \mu H, C_{OUT} = 330 \mu F, C_{OUT} ESR = 45 m\Omega$

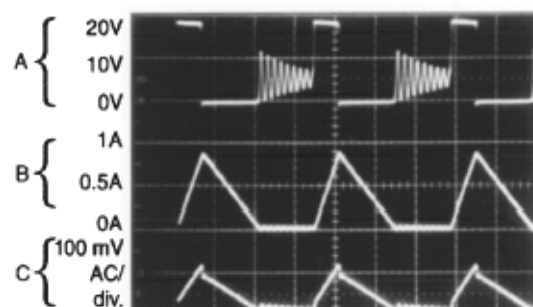

Horizontal Time Base: 2  $\mu s/div.$

A: Output Pin Voltage, 10V/div.  
 B: Inductor Current 0.5A/div.  
 C: Output Ripple Voltage, 100 mV/div.

Load Transient Response for Continuous Mode

$V_{IN} = 20V, V_{OUT} = 5V, I_{LOAD} = 500 mA \text{ to } 2A$   
 $L = 32 \mu H, C_{OUT} = 220 \mu F, C_{OUT} ESR = 50 m\Omega$

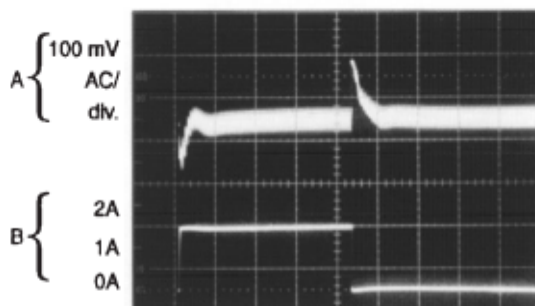

Horizontal Time Base: 100  $\mu s/div.$

A: Output Voltage, 100 mV/div. (AC)  
 B: 500 mA to 2A Load Pulse

Load Transient Response for Discontinuous Mode

$V_{IN} = 20V, V_{OUT} = 5V, I_{LOAD} = 500 mA \text{ to } 2A$   
 $L = 10 \mu H, C_{OUT} = 330 \mu F, C_{OUT} ESR = 45 m\Omega$

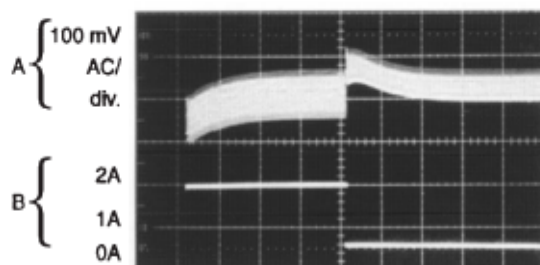

Horizontal Time Base: 200  $\mu s/div.$

A: Output Voltage, 100 mV/div. (AC)  
 B: 500 mA to 2A Load Pulse

Test Circuit and Layout Guidelines

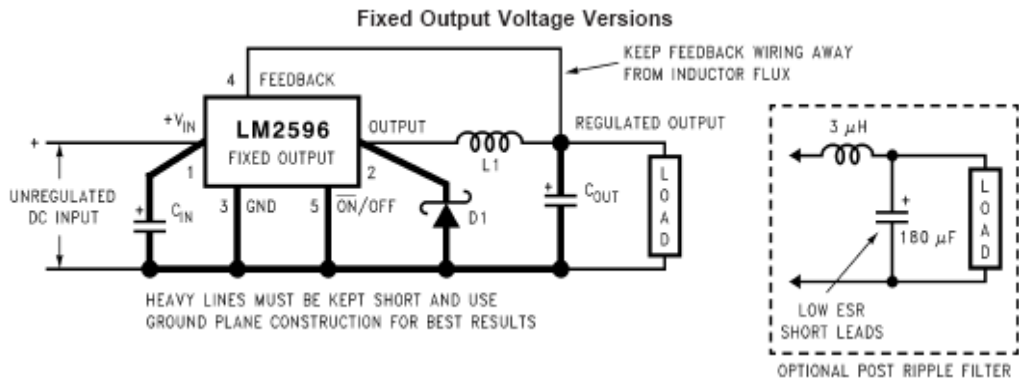

Cin = 470µF, 50V, Cout = 220µF, 25V (Aluminum Electrilytic Nichicon "PL Series")  
 D1 = 5A, 40V Schottky Rectifier, IN5825  
 L1 = 68uH, L38

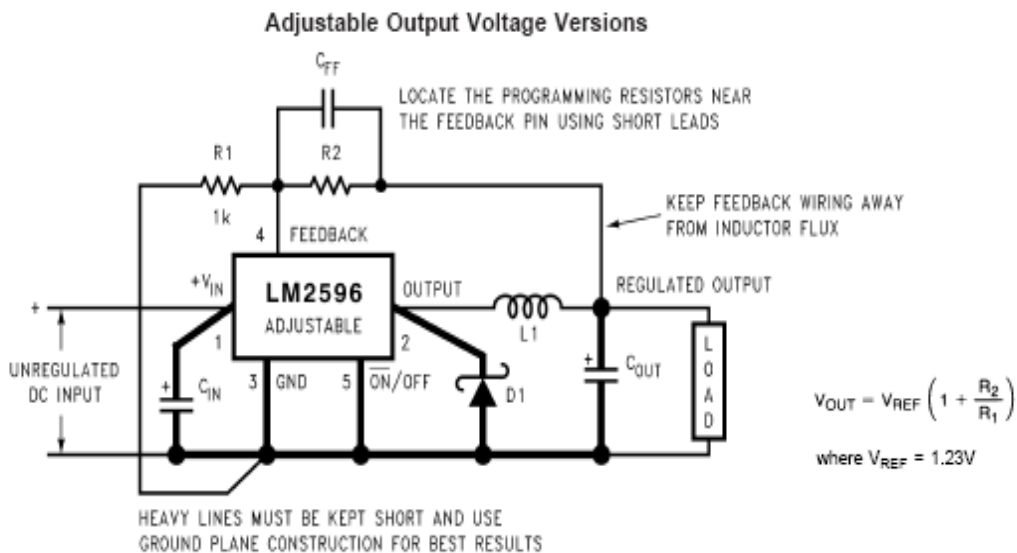

Cin = 470µF, 50V, Cout = 220µF, 35V (Aluminum Electrilytic Nichicon "PL Series")  
 D1 = 5A, 40V Schottky Rectifier, IN5825  
 L1 = 68uH, R1 = 1kΩ, 1% R2 = R1 x (Vout / Vref - 1)

Figure 2. Typical Test Circuits and Layout Guide

As in any switching regulator, layout is very important. Rapidly switching currents associated with wiring inductance can generate voltage transients which can cause problems. For minimal inductance and ground loops, the wires indicated by heavy lines should be wide printed circuit traces and should be kept as short as possible. For best results, external components should be located as close to the switching IC as possible using ground plane construction or single point grounding. If open core inductors are used, special care must be taken as to the location and positioning of this type of inductor. Allowing the inductor flux to intersect sensitive feedback, IC groundpath and COUT wiring can cause problems. When using the adjustable version, special care must be taken as to the location of the feedback resistors and the associated wiring. Physically locate both resistors near the IC, and route the wiring away from the inductor, especially an open core type of inductor.

## PIN FUNCTION DESCRIPTION

	Symbol	Description
1	Vin	This pin is the positive input supply for the LM2596 step-down switching regulator. In order to minimize voltage transients and to supply the switching currents needed by the regulator, a suitable input bypass capacitor must be present. (Cin in Figure 1).
2	Output	This is the emitter of the internal switch. The saturation voltage Vsat of this output switch is typically 1.5 V. It should be kept in mind that the PCB area connected to this pin should be kept to a minimum in order to minimize coupling to sensitive circuitry.
3	Gnd	Circuit ground pin. See the information about the printed circuit board layout.
4	Feedback	This pin senses regulated output voltage to complete the feedback loop. The signal is divided by the internal resistor divider network R2, R1 and applied to the non-inverting input of the internal error amplifier. In the Adjustable version of the LM2596 switching regulator this pin is the direct input of the error amplifier and the resistor network R2, R1 is connected externally to allow programming of the output voltage.
5	ON/OFF	It allows the switching regulator circuit to be shut down using logic level signals, thus dropping the total input supply current to approximately 80mA. The threshold voltage is typically 1.4V. Applying a voltage above this value (up to +Vin) shuts the regulator off. If the voltage applied to this pin is lower than 1.4V or if this pin is left open, the regulator will be in the "on" condition