

DATA SHEET

KA35S280;KA35S281
Lead-Acid Battery Charger

Product Specification

2011 Nov 18

Features:

- Optimum Control for Maximum Battery Capacity and Life
- Applicable to Various Types of Lead Battery
- Pin-Selectable Charge Algorithms (3 Step Voltage, Current, or Pulsed Charge)
- Automatically Shorted, Opened, or Damaged Cells Detections
- Automatically Battery Removal Detection
- Charge Condition LED Indicator Outputs (On, Pulsed, Off)
- Automatic Correction of Charging Current and Voltage Based on Current Temperature
- Maximum and Minimum Battery Temperature Protection
- Pre-Charge Qualification (Initial Trickle Charge for Deeply Discharged Batteries)
- Cycle/Float Button (For In-System Battery Charge Condition)
- Adjustable Charging Time Control by Changing the External Current Resistor
- Faster Charge Time Button
- Externally Disabling Charge Button
- Switch Mode Constant Current Generation
- Pb-Free (RoHS Compliant)

Applications:

- Handheld Equipment
- Portable Instruments and Communications
- Power Conditioning for Battery Systems
- Telecommunications
- Power Utility
- Emergency Lighting
- Control System
- Fire & Security
- Renewables
- UPS

Description:

The KA35S28X series of battery charger controllers contain all of the necessary circuitry to optimally control the charge and hold cycle for sealed lead-acid batteries. These integrated circuits monitor and control both the output voltage and current of the charger through three separate charge states; a high current bulk-charge state, a controlled over-charge, and a precision float-charge, or standby, state.

The Pulse-Width Modulator (PWM) provides control for high-efficiency current and voltage regulation. It allows the KA35S28X to control 3-step constant-voltage, constant current, or pulsed-current charging. A charge cycle begins when power is applied or the battery is replaced. For safety, charging is inhibited until the battery voltage is within configured limits. If the battery voltage is less than the low-voltage threshold, the KA35S28X provides trickle-current charging until the voltage rises into the allowed range. This procedure prevents high-current charging of cells that are possibly damaged or reversed.

Charging is inhibited anytime if the temperature of the battery is outside the configurable, allowed range. All voltage thresholds, in accordance with battery manufacturer's recommendations, are change proportional to the temperature conditions.

KA35S28X can receive the types of charging algorithm or stop charging commands from its mode selection pins. Also it can change the voltage thresholds when battery is connected to an electronic circuit or raises charge speed by 25% only by individual pins that named as "cycle/float" and "faster charge".

Ordering information:

Table 1. Ordering information

Type Number	Package				
	Temperature Range	Pins	Package	Material	Code
KA35S280-DN	-20°C to +85°C	14	DIP14	Plastic	SOT27-1
KA35S280-DI	-40°C to +125°C	14	DIP14	Plastic	SOT27-1
KA35S280-SN	-20°C to +85°C	14	SO14	Plastic	SOT108-1
KA35S280-SI	-40°C to +125°C	14	SO14	Plastic	SOT108-1
KA35S281-DN	-20°C to +85°C	14	DIP14	Plastic	SOT27-1
KA35S281-DI	-40°C to +125°C	14	DIP14	Plastic	SOT27-1
KA35S281-SN	-20°C to +85°C	14	SO14	Plastic	SOT108-1
KA35S281-SI	-40°C to +125°C	14	SO14	Plastic	SOT108-1

Pinning information

- Pining

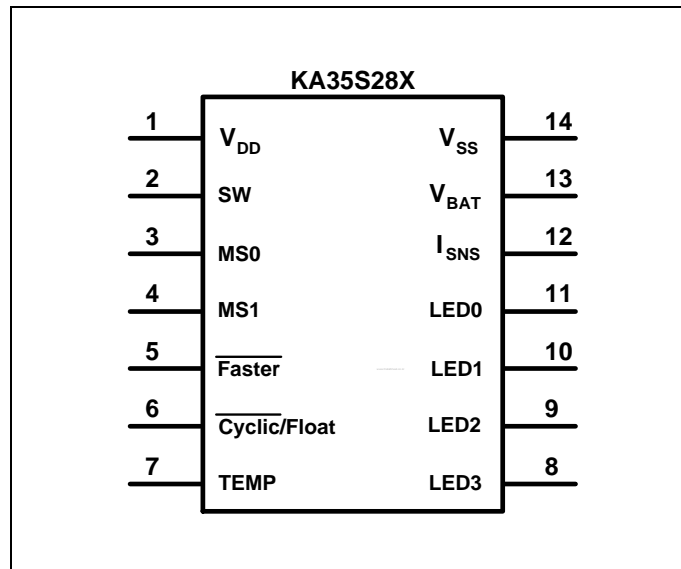

Figure 1 - Pin configuration

- Pin description

Table 2 – pin Description

Symbol	Pin	Description
V _{DD}	1	5.0V±10% power
SW	2	PWM Control Output
MS0	3	Mode Select 0
MS1	4	Mode Select 1
Faster	5	25% Faster Charging
Cyclic / Float	6	Select Between Cyclic and Float Applications
TEMP	7	Temperature Sense Input
LED3	8	Charge status output 3
LED2	9	Charge status output 2
LED1	10	Charge status output 1
LED0	11	Charge status output 0
I _{SNS}	12	Current Sense Input
V _{BAT}	13	Battery Voltage Sense Input
V _{SS}	14	System Ground

Functional diagram:

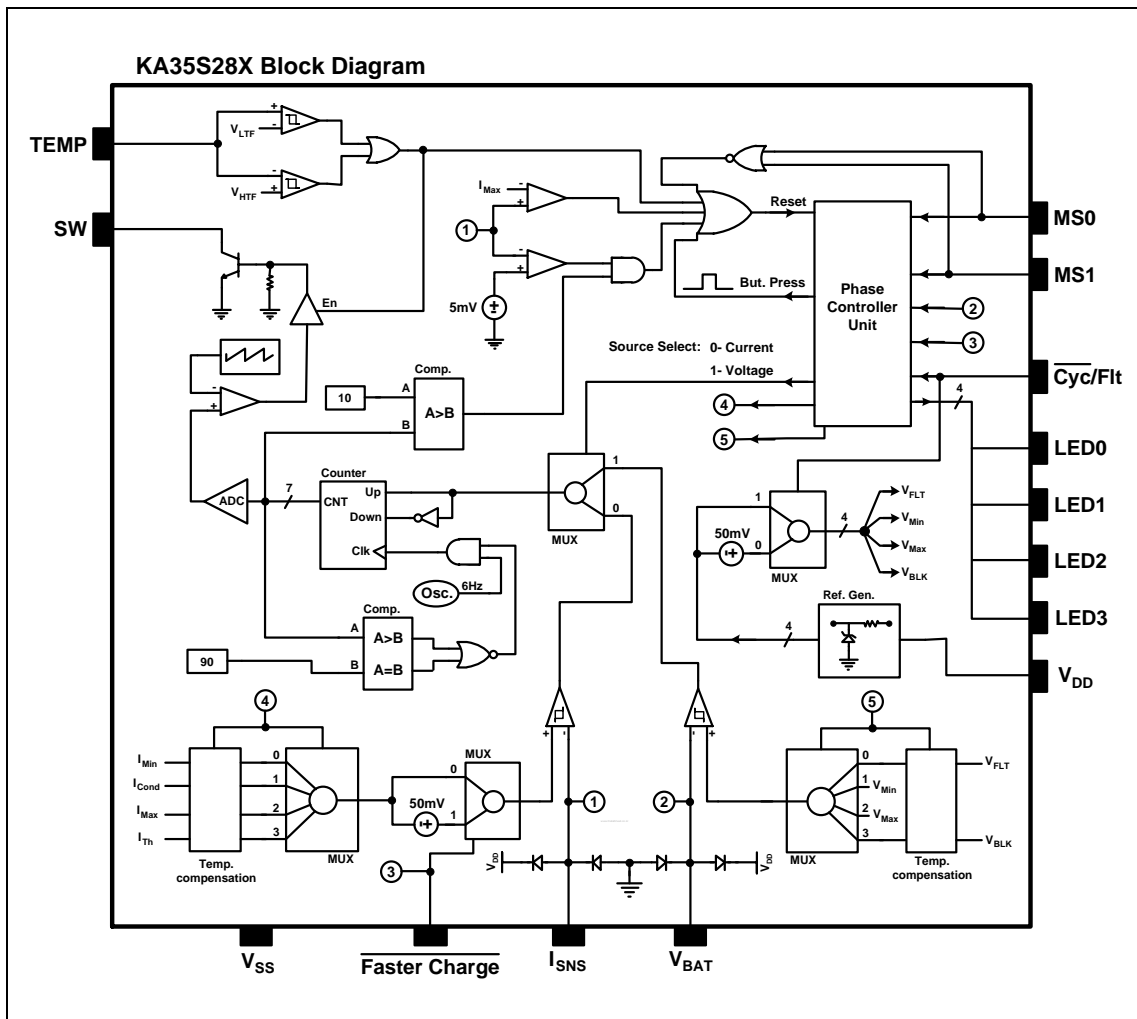

Figure 2 – KA35S28X Block Diagram

Functional description:

The KA35S28X functional operation is described in terms of:

- Pin configuration
 - Mode selection pins
 - Faster Charge pin
 - Cyclic/Float use pin
- Fixed and Configurable Thresholds
- Charge algorithms
 - 3-Step voltage charge
 - Current charge
 - Pulsed-current charge
- Temperature monitoring
 - Temperature compensation
 - Disabling Temperature Sensing
- Charge monitoring
- Fault detection
 - Battery insertion and removal
 - Shorted, opened, or damaged cells detections

- **Pin Configuration**
- **Mode selection pins**

The KA35S28X can be programmed into 3 different charge algorithm named as 3-step voltage, current and pulsed current by mode selection pins. Table 3 shows the relations between MS0/MS1 selection pins and IC operation.

Table 3 – Mode Selection pins

MS1	MS0	Mode	Description
0	0	0	Charge is disabled
0	1	1	3-step voltage charge
1	0	2	Current charge
1	1	3	Pulsed current Charge

- **Faster charge pin**

The faster charge pin can be change internal DC voltage threshold of max current by 25% (50mV). In normal condition it is configured to 200mV by internal voltage reference generator unit.

Table 4 – Mode Selection pins

Faster Pin	Description
0	Charge current increased by 25%
1	Normal current charge

- **Cyclic/Float use pin**

Due to recent design breakthroughs, the same battery may be used in either cyclic or standby applications and it is necessary to set the charge voltage according to it. Inaccurate voltage settings cause over- or under-charge. In applications where standby power is required to operate when the power has been interrupted, continuous float charging is recommended. Non-continuous cyclic charging is used primarily with portable equipment where charging on an intermittent basis is appropriate.

The cyclic/float pin can be change internal charge reference voltage and method of temperature compensation.

Table 5 – Mode Selection pins

Cyclic/Float Pin	Description
0	In cyclic use
1	In float use

- **Fixed and Configurable Thresholds**

The KA35S28X uses the following fixed thresholds:

- V_{MAX}** High-Cutoff Voltage: V_{BAT} rising above this level is interpreted as battery removal, cutting off charging current. $V_{MAX} = 0.6 * V_{CC}$.
- V_{MIN}** Low-Cutoff Voltage: V_{BAT} dropping below this level is interpreted as battery removal, cutting off charging current. $V_{MIN} = 0.2 * V_{CC}$.
- V_{TH}** Minimum Voltage: Used in pre-charge qualification. $V_{TH} = 0.34 * V_{CC}$.
- I_{COND}** Conditioning Current: Used in the maintenance phase of the Current algorithm and pre-charge qualification. $I_{COND} = I_{MAX}/5$. I_{MAX} is set by Equation 2.

Also the KA35S28X uses the following configurable thresholds:

- V_{BLK}** Upper voltage limit during fast charge, typically specified by the battery manufacturers to be 2.3V in float and 2.45 in cyclic applications per cell @ 25°C. KA35S28X uses 2.45V for V_{BLK} when Cyclic/Float pin is set 0.
- V_{FLT}** Minimum charge voltage required to compensate for the battery's self-discharge rate and maintain full charge on the battery.

I_{MAX} Fast charge current specified as a function of “C,” the capacity of the battery in Ampere-hours (e.g., a charge rate of 1C for a 5Ah battery is 5A). Typical values range from C/10 to C, although some battery vendors may approve higher charge rates.

The KA35S28X monitors battery pack voltage at the V_{BAT} pin. A voltage divider between the positive and negative terminals of the battery pack is used to present a scaled battery pack voltage to the V_{BAT} pin. The KA35S28X also uses the voltage across a sense resistor (R_{SNS}) between the negative terminal of the battery pack and ground to monitor current. See Figure 3 and below equations for the configuration of this network.

Equation 1:

$$\frac{RB_1}{RB_2} = \frac{N}{1.1} - 1$$

And I_{MAX} is determined by:

Equation 2:

$$I_{MAX} = \frac{0.2}{R_{SNS}}$$

Where:

N = Number of series cells in the battery pack

I_{MAX} = Desired maximum charge current

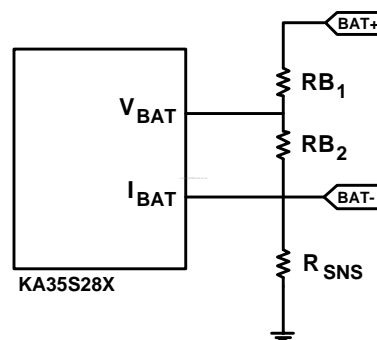

Figure 3 - Configuring the Battery Divider

The KA35S28X internal band-gap reference voltage at 25°C is 2.2V. This reference shifts with temperature at -3.9mV/°C to compensate for the negative temperature coefficient of lead-acid chemistry.

The total resistance presented by the divider between BAT+ and BAT- (RB1 + RB2) should be between 100KΩ and 1MΩ. The minimum value ensures that the divider network does not drain the battery excessively when the power source is disconnected. Exceeding the maximum value increases the noise susceptibility of the V_{BAT} pin. 1% resistors are recommended.

Table 6 shows the several examples of resistor selections.

Table 6 – RB₁, RB₂ Values by Number of Cells and R_{SNS} by Desired I_{MAX}

N	RB ₁ (KΩ)	RB ₂ (KΩ)	I _{MAX}	R _{SNS} (Ω)
3 (6V)	57KΩ	33KΩ	0.5	0.4Ω
6 (12V)	147KΩ	33KΩ	1A	0.2Ω
12 (24V)	327KΩ	33KΩ	1.5A	0.13Ω

- Charge algorithms
- 3-Step voltage charge

This algorithm consists of four phases (figure 4):

1. Phase1 - Qualification: The charging current is limited at I_{COND} ($=I_{MAX}/5$) until the cell voltage rises to V_{TH} to prevent battery damage. In this condition The KA35S28X enters the Charge Pending state and waits until the battery voltage rises to V_{TH} . Charge Pending is annunciated by LED0 and LED3 flashing.
2. Phase2 - Fast Charge 1: The charging current is limited at I_{MAX} ($1.25 I_{MAX}$ when faster pin is 0) until the cell voltage rises to V_{BLK} .
3. Phase3 - Fast Charge 2: The charging voltage is regulated at V_{BLK} until the charging current drops below I_{MIN} ($0.1I_{MAX}$)
4. Phase4 - Maintenance: The charging voltage is regulated at V_{FLT} .

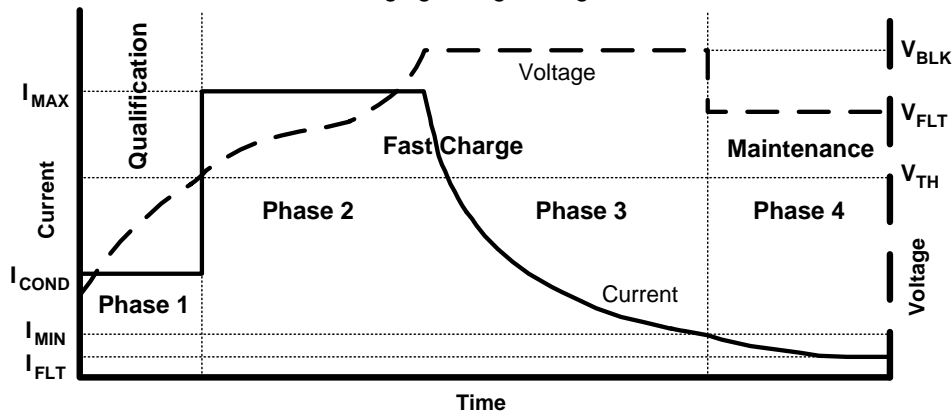

Figure 4 – 3-Step Voltage Charge

- Current charge

This algorithm consists of three phases (figure 5):

1. Phase1 - Qualification: The charging current is limited at I_{COND} ($=I_{MAX}/5$) until the cell voltage rises to V_{TH} to prevent battery damage. In this condition The KA35S28X enters the Charge Pending state and waits until the battery voltage rises to V_{TH} . Charge Pending is annunciated by LED0 and LED3 flashing.
2. Phase2 - Fast Charge: The charging current is regulated at I_{MAX} ($1.25 I_{MAX}$ when faster pin is 0) until the cell voltage rises to V_{BLK} or the “Second Difference” of cell voltage drops below $-8mV$ while V_{BAT} is over $2.0V$.
3. Phase3 - Maintenance: Fixed-width pulses of charging current = I_{COND} are modulated in frequency to achieve an average value of I_{MIN} ($0.1I_{MAX}$).

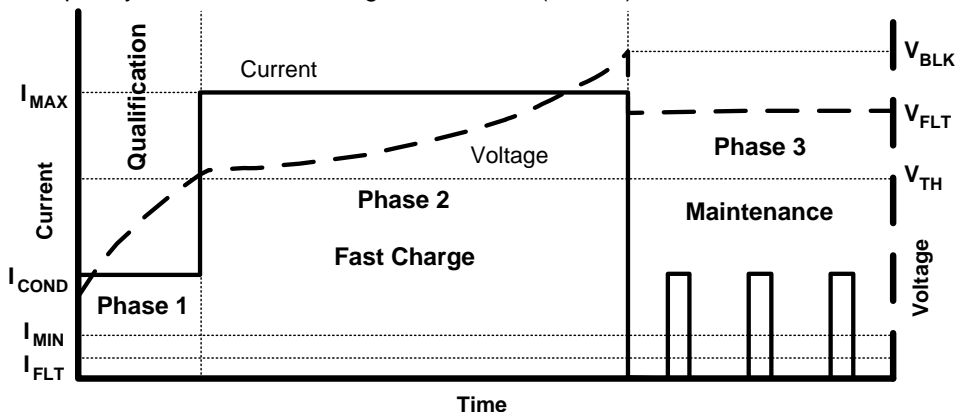

Figure 5 – Current Charge

- **Pulsed-current charge**

This algorithm consists of three phases (figure 6):

1. Phase1 - Qualification: The charging current is limited at I_{COND} ($=I_{MAX}/5$) until the cell voltage rises to V_{TH} to prevent battery damage. In this condition The KA35S28X enters the Charge Pending state and waits until the battery voltage rises to V_{TH} . Charge Pending is annunciated by LED0 and LED3 flashing.
2. Phase2 - Fast Charge: The charging current is regulated at I_{MAX} ($1.25 I_{MAX}$ when faster pin is 0) until the cell voltage rises to V_{BLK} .
3. Phase3 - Maintenance: Charging current is removed until the battery voltage falls to V_{FLT} ; charging current is then restored and regulated at I_{MAX} ($1.25 I_{MAX}$ when faster pin is 0) until the battery voltage once again rises to V_{BLK} . This cycle is repeated indefinitely.

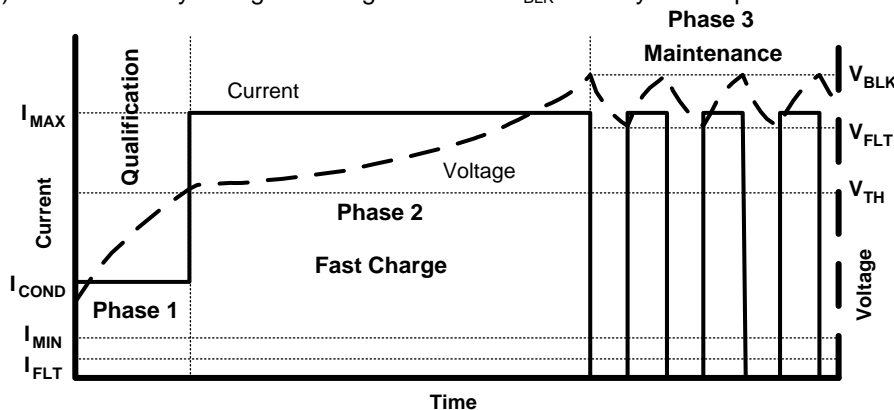

Figure 6 – Fast Charge

- **Temperature monitoring**
- **Temperature compensation**

The KA35S28X senses temperature by monitoring the voltage of TEMP pin. The KA35S28X assumes a Negative Temperature Coefficient (NTC) thermistor, so the voltage on the TEMP pin is inversely proportional to the temperature (see Figure 7). The temperature thresholds used by the KA35S28X and their corresponding TEMP pin voltage are:

TCO Temperature Cut-Off: Higher limit of the temperature range in which charging is allowed. $V_{TCO} = 0.12 * V_{CC}$.

HTF High-Temperature Fault: Threshold to which temperature must drop after Temperature Cut-Off is exceeded before charging can begin again. $V_{HTF} = 0.15 * V_{CC}$

LTF Low-Temperature Fault: Lower limit of the temperature range in which charging is allowed. $V_{LTF} = 0.35 * V_{CC}$.

A resistor-divider network must be implemented that presents the defined voltage levels to the TEMP pin at the desired temperatures (see Figure 8). The equations for determining RT_1 and RT_2 are:

Equation 1:

$$RT_1 = \frac{3.81R_{HTF}R_{LTF}}{R_{LTF} - R_{HTF}}$$

Equation 2:

$$RT_2 = \frac{0.67R_{HTF}R_{LTF}}{0.33R_{LTF} - R_{HTF}}$$

Where:

R_{LTF} = Thermistor resistance at LTF

R_{HTF} = Thermistor resistance at HTF

1% resistors are recommended. As an example, the resistor values for several temperature windows computed for a 3KΩ thermistor are shown in Table 7.

Table 7 – RT_1 and RT_2 Values for Temperature Thresholds

LTF (°C)	HTF (°C)	RT_1	RT_2
5 °C	45 °C	8.18K Ω	15.22K Ω
0 °C	50 °C	7.50K Ω	11.25K Ω
-5 °C	55 °C	6.85K Ω	8.72K Ω

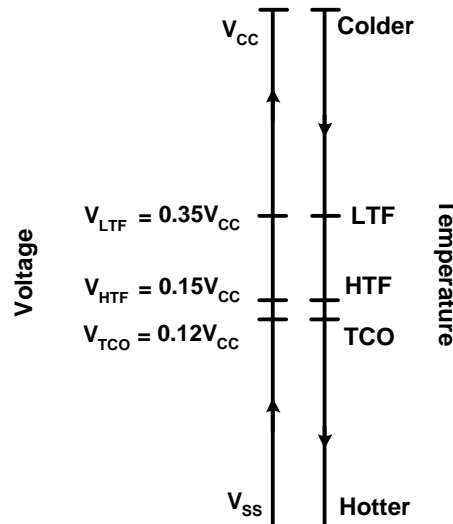

Figure 7 – Voltage Equivalent of Temperature Threshold

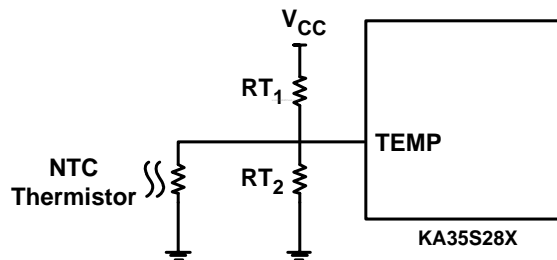

Figure 8 – Configuring Temperature Sensing

- Disabling Temperature Sensing

Temperature sensing may be disabled by removing the thermistor and use a single Pull up or Pull down resistor connected to TEMP pin as shown in figure 9.

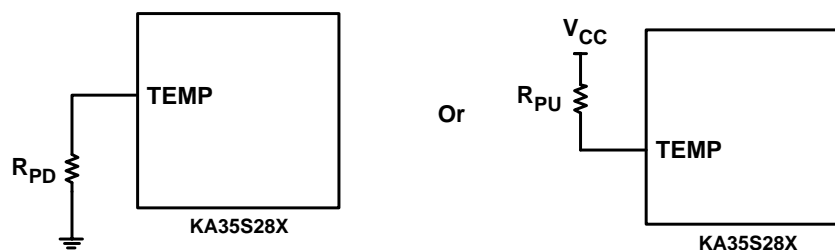

Figure 9 – Disabling Temperature Sensing

where:

R_{PU} = Pull up resistor (Can be select 1K Ω)
 R_{PD} = Pull down resistor (Can be select 1K Ω)

- **Charge monitoring**

Charge status (figure 10) is announced by the LED driver outputs LED1 - LED3 (figure 11)

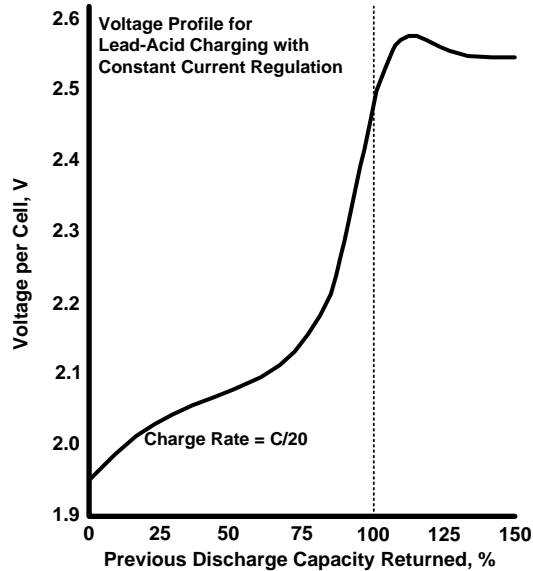

Figure 10 - Voltage Roll-Off In Constant Current Charging Profile

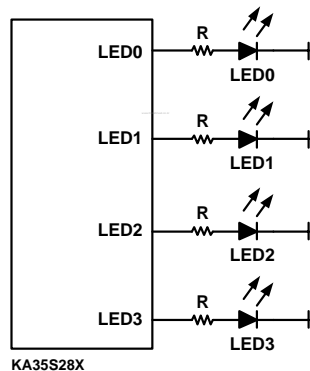

Figure 11 – LED Display

- **Fault detection**
- **Battery insertion and removal**

The KA35S28X uses V_{BAT} to detect the presence or absence of a battery. The KA35S28X determines that a battery is present when V_{BAT} is between the High-Voltage Cutoff and the Low-Voltage Cutoff. When V_{BAT} is outside this range, the KA35S28X determines that no battery is present and transitions to the Fault state. Also, sudden changes in battery voltage can cause the fault state.

- **Shorted, opened, or damaged cells detections**

The KA35S28X can be detect shorted, opened, and damaged cells by using one of the following below state:

1. High current detection
2. Non-rechargeable batteries detection
3. Changing in any of the buttons

Typical Application

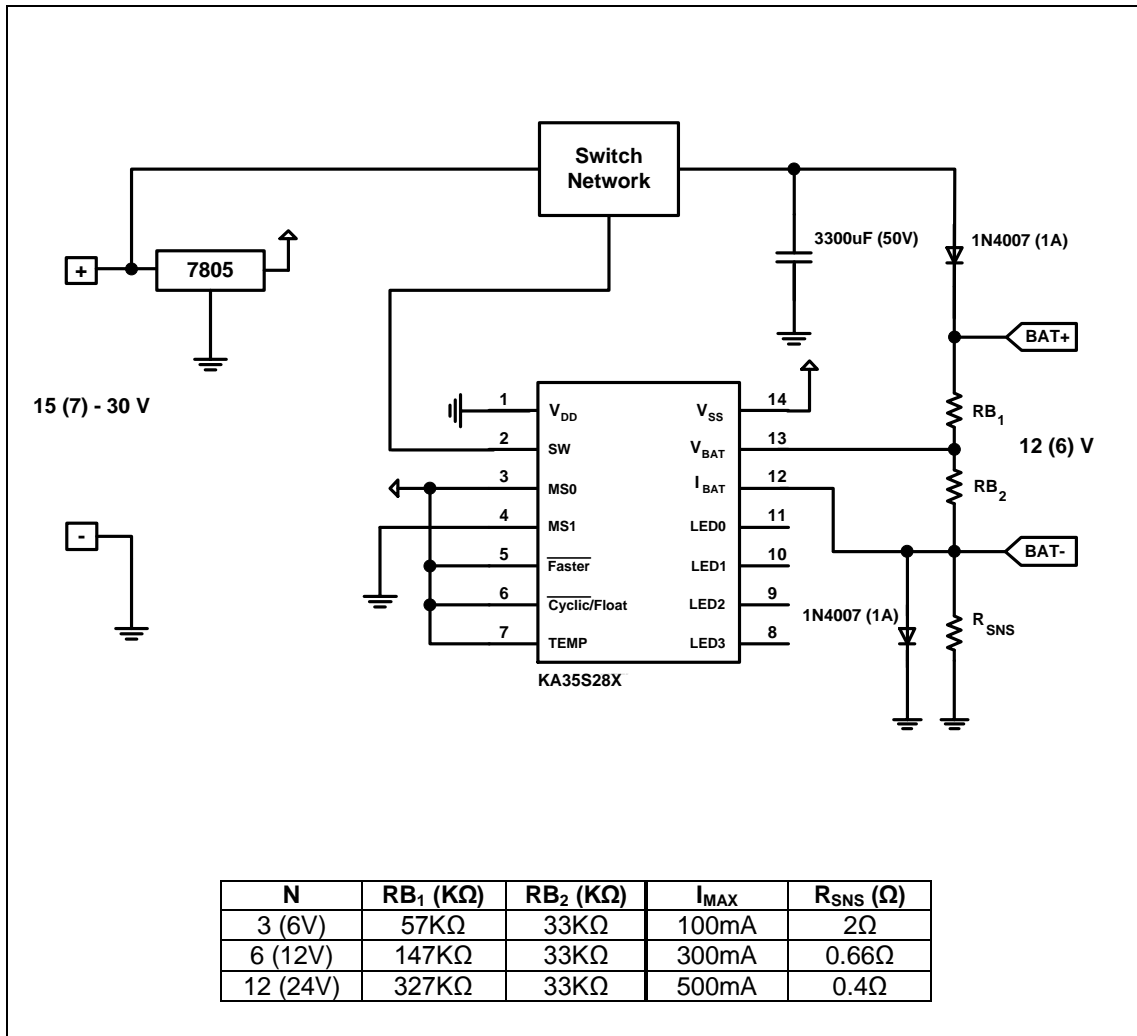

Figure 12 – A Very Simple High Power 3-Step Voltage Lead-Acid Battery Charger

Typical Application

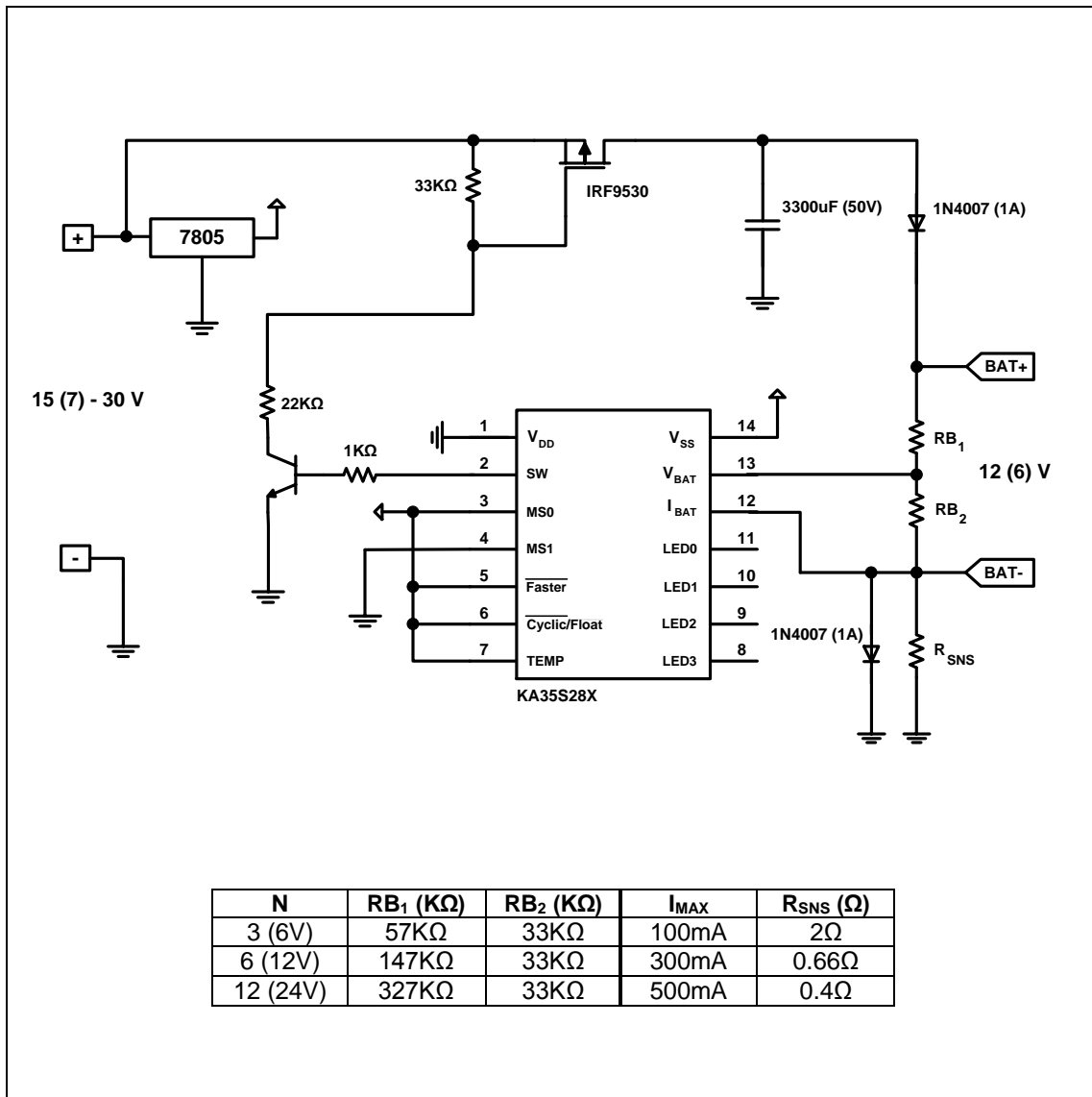

Figure 13 – Schematic Diagram of A Very Simple High Power 3-Step Voltage Lead-Acid Battery Charger

Typical Application

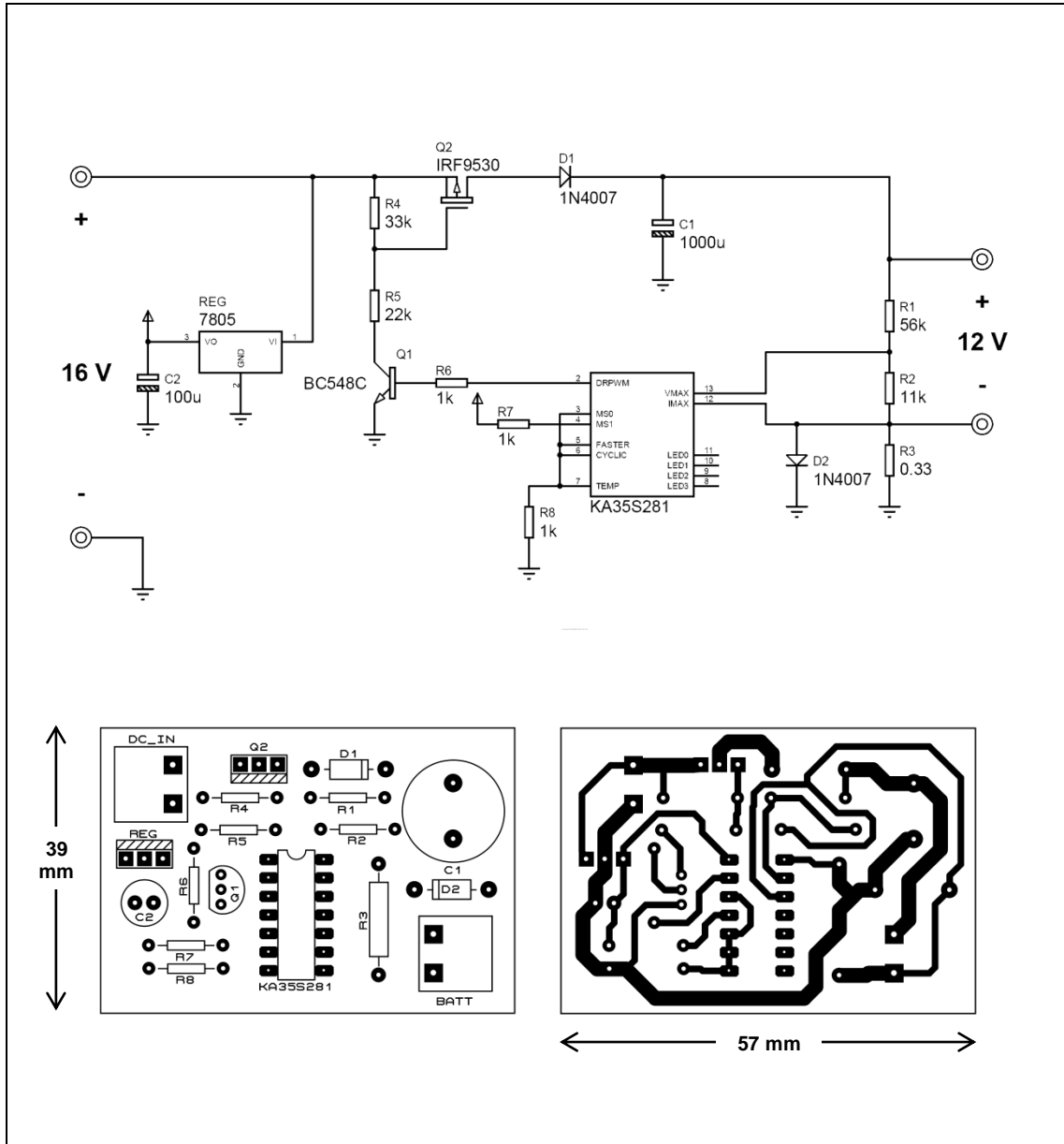

Figure 14 – Schematic Diagram and PCB Layout of a Very Simple 3-Step Voltage of Lead-Acid Battery Charger

Typical Application

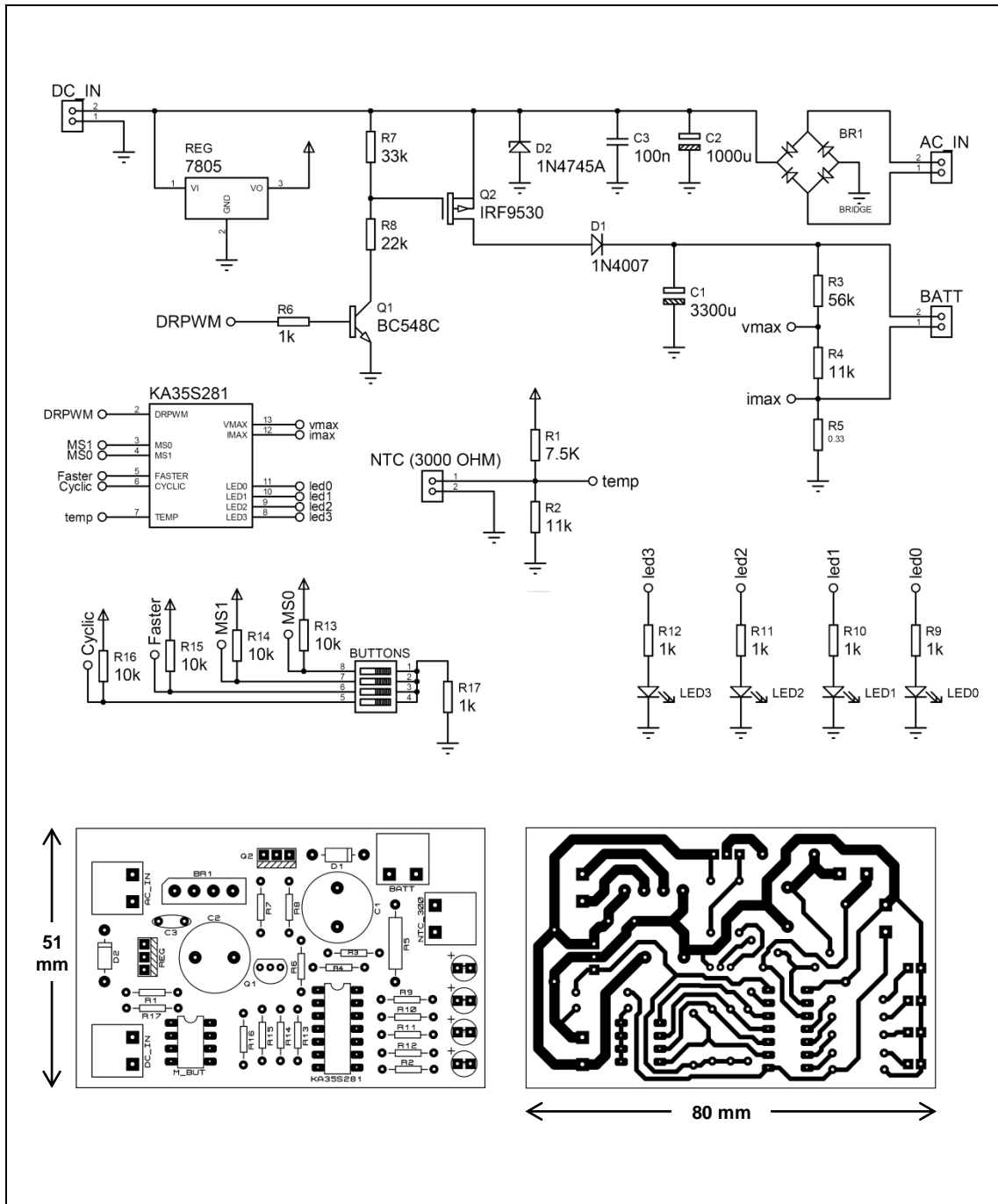

Figure 15 – Schematic Diagram and PCB Layout of Lead-Acid Battery Charger with Programmable Charge Algorithm, Faster and Cyclic Charge Buttons, LED Display, Selectable DC or AC Power Input and Temperature Sensor

Absolute Maximum Ratings:

Table 8 – Absolute Maximum Ratings

Symbol	Parameter	Min.	Max.	Unit	Note
V _{DD}	V _{CC} relative to V _{SS}	-0.3	6.5	V	
V _T	DC voltage applied on any pin excluding V _{DD} relative to V _{SS}	-0.3	6.5	V	
T _{OPR}	Operating ambient temperature	-20 (-40°)	+85 (+125°)	°C	
T _{STG}	Storage temperature	-55	+125 (+150)	°C	
T _{SOLDER}	Soldering temperature	---	+260	°C	10 s. max.

*- In KA35S28X-XI series.

DC Thresholds:

Table 9 – Absolute Maximum Ratings

Symbol	Parameter	Rating	Unit	Tolerance	Note
V _{REF}	Internal reference voltage	2.00	V	1%	T _A =25°C
	Temperature coefficient	-3.9	mV/°C	10%	
V _{LTF}	TEMP maximum threshold	0.35*V _{DD}	V	±0.02V	
V _{HTF}	TEMP hysteresis threshold	0.15*V _{DD}	V	±0.02V	
V _{TCO}	TEMP minimum threshold	0.12*V _{DD}	V	±0.02V	
V _{MAX}	High cutoff voltage	0.6*V _{DD}	V	±0.02V	
V _{MIN}	Under-voltage threshold at BAT	0.2*V _{DD}	V	±0.02V	
V _{TH}	Low cutoff voltage	0.34*V _{DD}	V	±0.02V	
V _{SNS}	Current sense at SNS	0.200	V	10%	I _{MAX}
		0.040	V	10%	I _{Cond}

Recommended operating conditions:

Table 10 – Absolute Maximum Ratings

Symbol	Parameter	KA35S28X-XN			KA35S28X-XI			Unit
		Min.	Typ.	Max.	Min.	Typ.	Max.	
V _{DD}	Supply voltage	4.5	5.0	5.5	4.5	5.0	5.5	V
V _{TEMP}	TEMP voltage potential	0	-	V _{DD}	0	-	V _{DD}	V
V _{BAT}	Battery voltage potential	0	-	V _{DD}	0	-	V _{DD}	V
I _{CC}	Supply current	-	3	5	-	3	5	V
V _{IH}	Logic input high	V _{DD} -0.6	-	-	V _{DD} -0.6	-	-	V
V _{IL}	Logic input low	-	-	V _{SS} +0.3	-	-	V _{SS} +0.3	V
V _{OH}	LEDX output high	V _{DD} -0.7	-	-	V _{DD} -0.7	-	-	V
V _{OL}	LEDX output low	-	-	V _{SS} +0.5	-	-	V _{SS} +0.5	V
I _{OH}	LEDX output source	-15	-	-	-15	-	-	mA
I _{OL}	LEDX output sink	15	-	-	15	-	-	mA
I _{IL}	logic input low source	-	-	35	-	-	35	µA
I _{IH}	logic input high source	-	-	-40	-	-	-40	µA

Package outline:

DIP16: plastic dual in-line package; 16 leads (300 mil)

SOT27-1

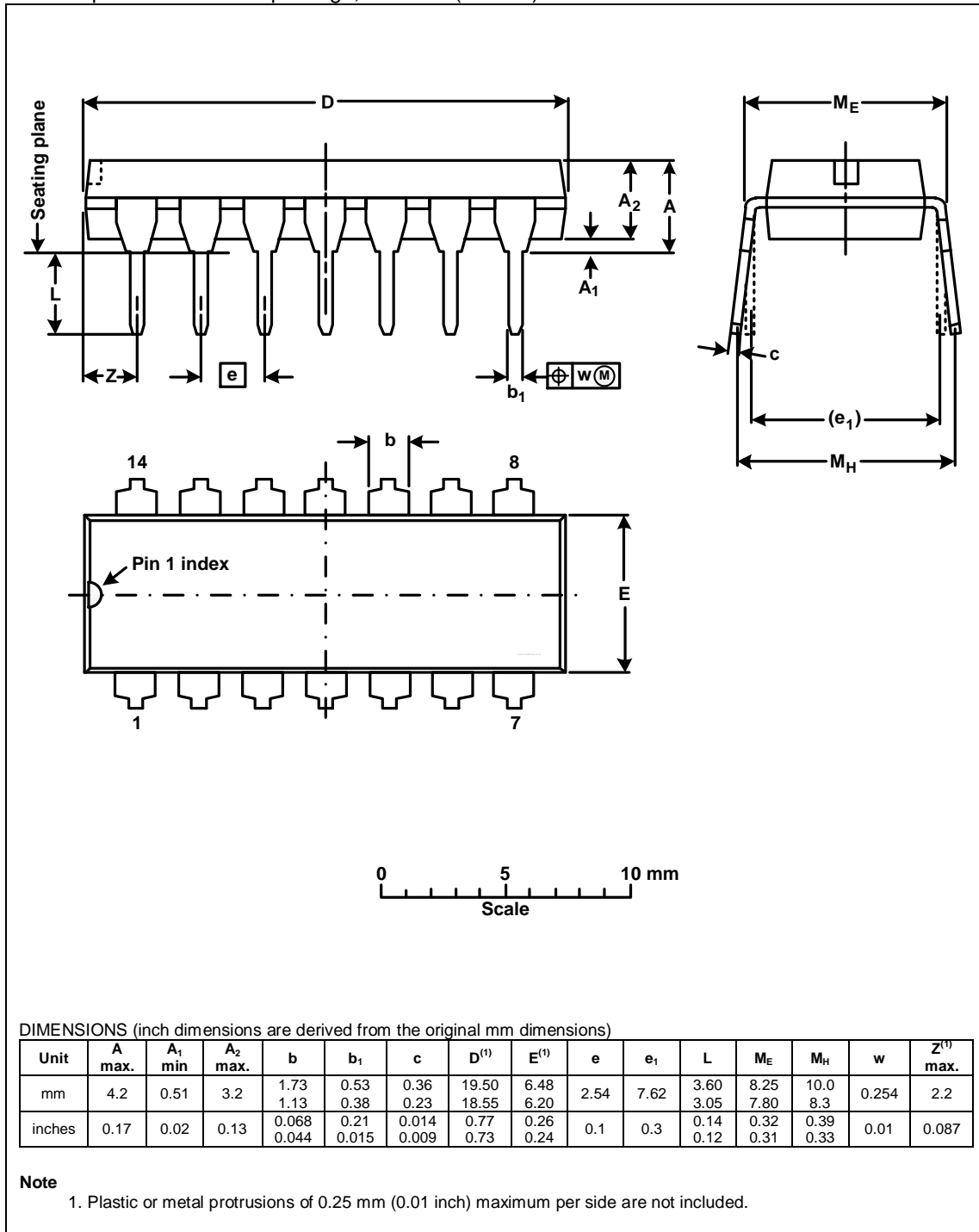
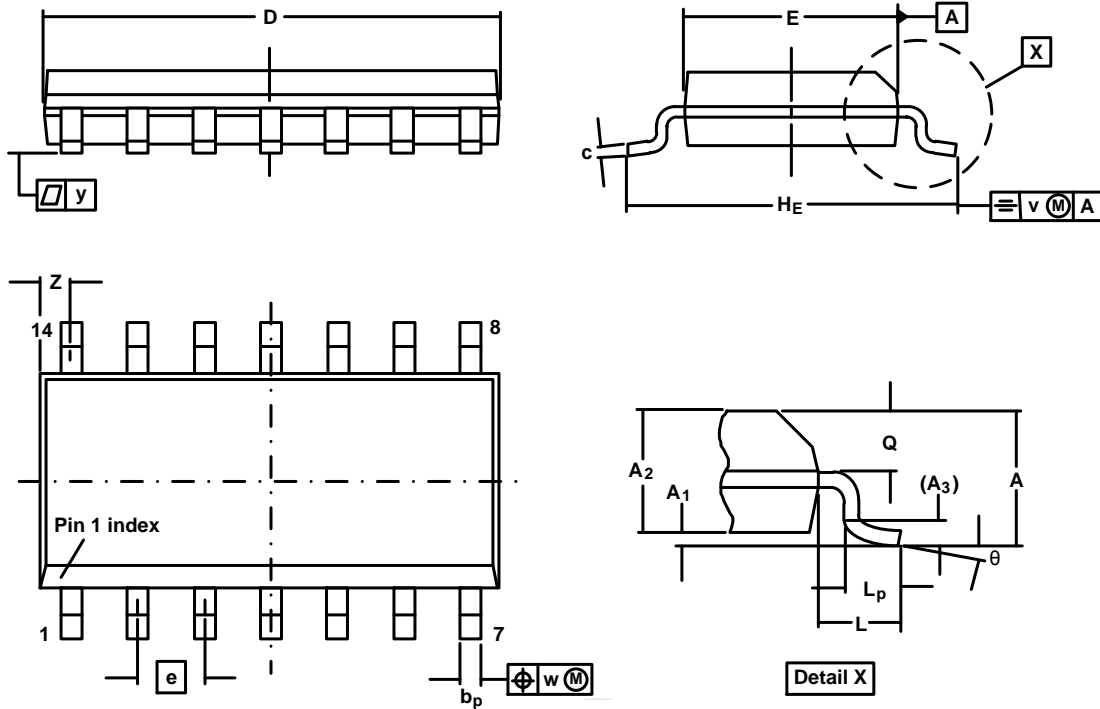

Figure 16 - Package outline SOT27-1

SO14: plastic small outline package; 14 leads; body width 3.9 mm

SOT108-1



DIMENSIONS (inch dimensions are derived from the original mm dimensions)

Unit	A max.	A ₁	A ₂	A ₃	b _p	c	D ⁽¹⁾	E ⁽¹⁾	e	H _E	L	L _p	Q	v	w	y	Z ⁽¹⁾ max.	θ
mm	1.75	0.25 0.10	1.45 1.25	0.25	0.49 0.36	0.25 0.19	8.75 8.55	4.0 3.8	1.27	6.2 5.8	1.05	1.0 0.4	0.7 0.6	0.25	0.25	0.1	0.7 0.3	8°
inches	0.069	0.010 0.004	0.057 0.049	0.01	0.019 0.014	0.010 0.007	0.35 0.34	0.16 0.15	0.05	0.244 0.228	0.041	0.039 0.016	0.028 0.024	0.01	0.01	0.004	0.028 0.012	0°

Note

1. Plastic or metal protrusions of 0.15 mm (0.006 inch) maximum per side are not included.

Figure 17 - Package outline SOT108-1

DATA SHEET STATUS

LEVEL	DATA SHEET STATUS ⁽¹⁾	PRODUCT STATUS ⁽²⁾⁽³⁾	DEFINITION
I	Objective data	Development	This data sheet contains data from the objective specification for product development. Kasin Corporation reserves the right to change the specification in any manner without notice.
II	Preliminary data	Qualification	This data sheet contains data from the preliminary specification. Supplementary data will be published at a later date. Kasin Corporation reserves the right to change the specification without notice, in order to improve the design and supply the best possible product.
III	Product data	Production	This data sheet contains data from the product specification. Kasin Corporation reserves the right to make changes at any time in order to improve the design, manufacturing and supply. Relevant changes will be communicated via a Customer Product/Process Change Notification (CPCN).

Notes

1. Please consult the most recently issued data sheet before initiating or completing a design.
2. The product status of the device(s) described in this data sheet may have changed since this data sheet was published. The latest information is available on the Internet at URL <http://www.kasincorp.com>.
3. For data sheets describing multiple type numbers, the highest-level product status determines the data sheet status.

DEFINITIONS

Short-form specification - The data in a short-form specification is extracted from a full data-sheet with the same type number and title. For detailed information see the relevant data sheet or data handbook.

Limiting values definition - Limiting values given are in accordance with the Absolute Maximum Rating System (IEC 60134). Stress above one or more of the limiting values may cause permanent damage to the device. These are stress ratings only and operation of the device at these or at any other conditions above those given in the Characteristics sections of the specification is not implied. Exposure to limiting values for extended periods may affect device reliability.

Application information - Applications that are described herein for any of these products are for illustrative purposes only. Kasin Corporation make no representation or warranty that such applications will be suitable for the specified use without further testing or modification.

DISCLAIMERS

Life support applications - These products are not designed for use in life support appliances, devices, or systems where malfunction of these products can reasonably be expected to result in personal injury. Kasin Corporation customers using or selling these products for use in such applications do so at their own risk and agree to fully indemnify Kasin Corporation for any damages resulting from such application.

Right to make changes - Kasin Corporation reserves the right to make changes in the products including circuits, standard cells, and/or software described or contained herein in order to improve design and/or performance. When the product is in full production (status 'Production'), relevant changes will be communicated via a Customer Product/Process Change Notification (CPCN). Kasin Corporation assumes no responsibility or liability for the use of any of these products, conveys no licence or title under any patent, copyright, or mask work right to these products, and makes no representations or warranties that these products are free from patent, copyright, or mask work right infringement, unless otherwise specified.

Notes:

Contact information:

For additional information please visit: <http://www.kasincorp.com>.
For sales offices addresses send e-mail to: sales@kasincorp.com.

© Kasin Corporation Electronics N.V. 2011

All rights are reserved. Reproduction in whole or in part is prohibited without the prior written consent of the copyright owner.
The information presented in this document does not form part of any quotation or contract, is believed to be accurate and reliable and may be changed without notice. No liability will be accepted by the publisher for any consequence of its use. Publication thereof does not convey nor imply any license under patent- or other industrial or intellectual property rights.