

FEATURES

- -33 to +5 dB Gain (user adjustable)
- Accepts single-ended or differential inputs
- Differential output
- High Linearity, Low Distortion
- 37 dB of Gain Control Range
- Wideband Operation: to Above 1.1 GHz
- 4.5 dB Typical Noise Figure at 5 dB Gain
- Single +5 V Supply
- RoHS Compliant/Lead-Free Package
- 3 mm x 3 mm x 1 mm QFN Package

APPLICATIONS

- CATV Digital Set Top Boxes
- Television Receiver Front-Ends
- Replacement for Passive Balun with Separate Gain Stage

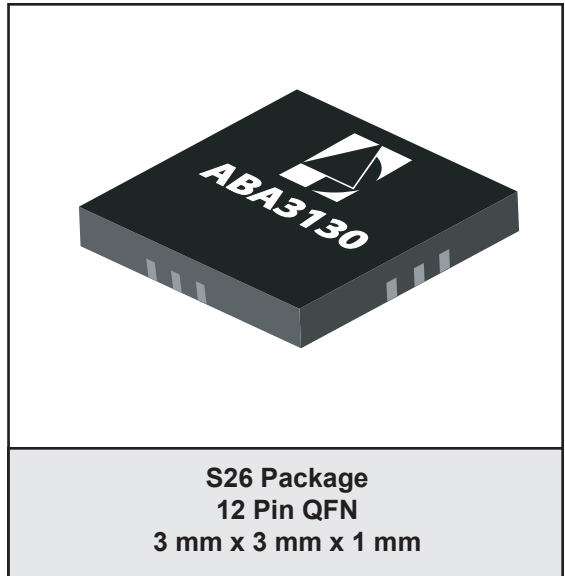

PRODUCT DESCRIPTION

The ABA3130 is a low noise amplifier with gain control that accepts a single-ended or differential RF input in the 50 MHz to 1.1 GHz frequency range and provides a balanced RF output with minimal degradation in signal quality. This highly integrated device amplifies the input signal using a highly linear, low noise amplification stage. Alternately, it can be used as a signal attenuator using the appropriate gain/attenuation control voltage. The overall linearity is maintained across a wide gain

control range, ensuring low distortion effects on the output signal. Requiring a single +5 V supply, the ABA3130 design is implemented using ANADIGICS' own high-reliability GaAs MESFET process. The small, surface mount QFN packaging makes this device ideal for use in Cable TV set-top boxes, television receiver front-ends, and other low noise applications. The device is characterized for both 75 Ω and 50 Ω systems.

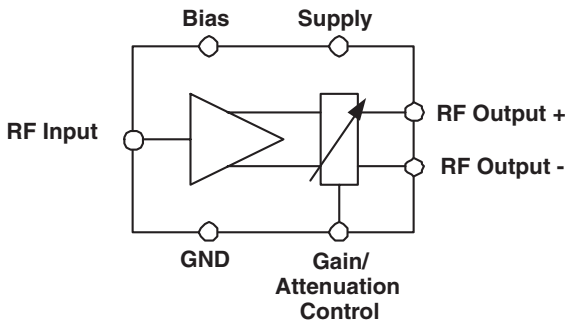

Single Ended Input
(No balun required)

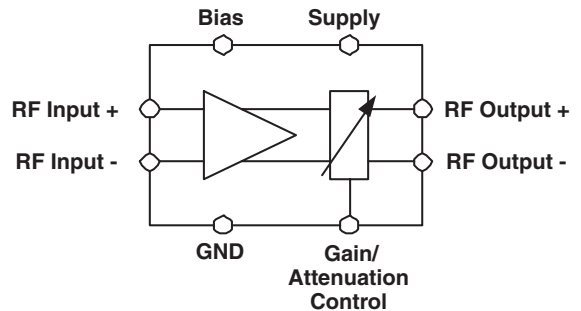

Differential Input

Figure 1: Functional Block Diagrams

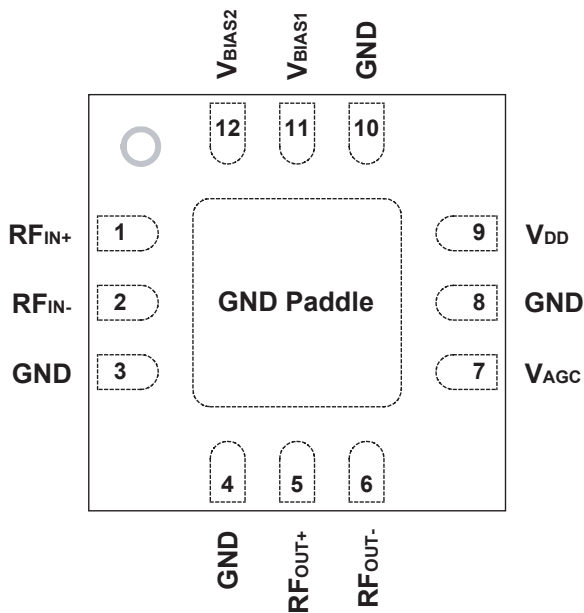

Figure 2: Pinout (X-ray Top View)

Table 1: Pin Description

PIN	NAME	DESCRIPTION
1	RF _{IN+}	RF Input (+)
2	RF _{IN-}	RF Input (-)
3	GND	Ground
4	GND	Ground
5	RF _{OUT+}	RF Output (+)
6	RF _{OUT-}	RF Output (-)
7	V _{AGC}	Gain/Attenuation Control
8	GND	Ground
9	V _{DD}	Supply Voltage
10	GND	Ground
11	V _{BIAS1}	Bias1 Voltage
12	V _{BIAS2}	Bias2 Voltage

ELECTRICAL CHARACTERISTICS

Table 2: Absolute Minimum and Maximum Ratings

PARAMETER	MIN	MAX	UNIT	COMMENTS
Supply Voltage (V_{CC})	0	+8	V	
AGC Input Voltage (V_{AGC})	0	+5	V	
RF Input Power (P_{IN})	-	+25	dBmV	

Stresses in excess of the absolute ratings may cause permanent damage. Functional operation is not implied under these conditions. Exposure to absolute ratings for extended periods of time may adversely affect reliability.

Table 3: Operating Ranges

PARAMETER	MIN	TYP	MAX	UNIT	COMMENTS
Operating Frequency (f)	50	-	1100	MHz	
Supply Voltage (V_{DD})	+3.3	+5.0	+5.5	V	
AGC Input Voltage (V_{AGC})	0	-	+5	V	
RF Input Power (P_{IN})	-15	-	+15	dBmV	
Case Temperature (T_C)	-40	-	+85	°C	

The device may be operated safely over these conditions; however, parametric performance is guaranteed only over the conditions defined in the electrical specifications.

Table 4: Electrical Specifications - 75 Ω system
 (T_c = +25 °C, V_{DD} = +5 V, I_{DD} = 80 mA)

PARAMETER	MIN	TYP	MAX	UNIT	COMMENTS
Gain at Maximum V _{AGC}	4	4.3	6	dB	at 55 MHz
Gain at Maximum V _{AGC}	2.8	-	-	dB	at 853 MHz
Gain at Minimum V _{AGC}	-41	-33	-30	dB	at 55 MHz
Gain Flatness	-	±1	-	dB	
AGC Input Voltage (V _{AGC})	0.3	-	3.0	V	Max. Gain at +3 V
Noise Figure at Maximum Gain	-	4.5	5	dB	V _{AGC} = +3 V
CTB ⁽¹⁾	-	-63	-50	dBc	
CSO ⁽¹⁾	-	-62	-48	dBc	
XMOD ⁽¹⁾	-	-63	-	dBc	
Reverse Isolation	-	-30	-	dB	
Input Return Loss	-13	-	-	dB	75 Ω , single-ended
Output Return Loss	-13	-	-	dB	75 Ω , differential
Supply Current (I _{DD})	50	80	100	mA	

Notes:

(1) 79 flat analog channels at +15 dBmV input power, plus 53 digital channels at +9 dBmV input power, and an output power of -7 dBmV.

Table 5: Electrical Specifications - 50 Ω system
 ($T_c = +25\text{ }^\circ\text{C}$, $V_{DD} = +5\text{ V}$, $I_{DD} = 78\text{ mA}$)

PARAMETER	MIN	TYP	MAX	UNIT	COMMENTS
Gain at Maximum V_{AGC}	-	4.2	-	dB	at 450 MHz
Gain at Minimum V_{AGC}	-	-34	-	dB	at 450 MHz
Gain Flatness	-	± 1	-	dB	
AGC Input Voltage (V_{AGC})	0.3	-	3.0	V	Max. Gain at +3 V
Noise Figure at Maximum Gain	-	4.2	5.5	dB	$V_{AGC} = +3.0\text{ V}$
OIP3	-	15.5	-	dBm	two tones: 510 and 511 MHz
	-	15.0	-	dBm	two tones: 860 and 861 MHz P_{OUT} per tone = -5 dBm
OIP2	-	51.0	-	dBm	two tones: 222 and 228 MHz
	-	48.6	-	dBm	two tones: 427 and 433 MHz P_{OUT} per tone = -5 dBm
P1dB (Output power at 1dB compression)	-	8.3	-	dBm	at 450 MHz, $V_{AGC} = 3.0\text{ V}$

Notes:

(1) 50 Ω tests measured using Figure 18, but with $C1 = 0.5\text{ pF}$ and $L3 = 5.6\text{ nH}$.

(2) Tested with balun on output (see Figure 18).

PERFORMANCE DATA - 75 Ω System

Figure 3: Gain (S21) vs. Frequency
(T_C = +25 °C, V_{DD} = +5 V)

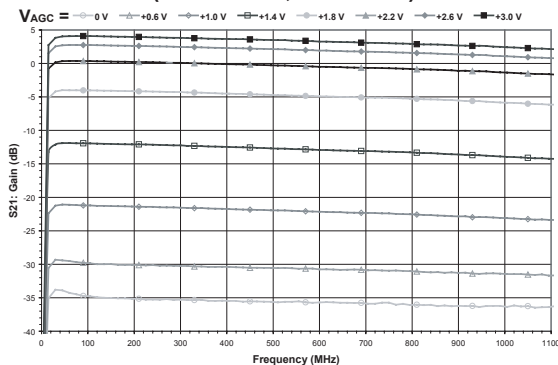

Figure 4: Input Return Loss (S11) vs. Frequency
(T_C = +25 °C, V_{DD} = +5 V)

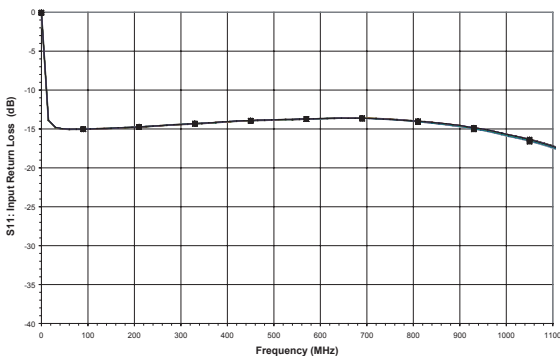

Figure 5: Reverse Isolation (S12) vs. Frequency
(T_C = +25 °C, V_{DD} = +5 V, V_{AGC} = +3 V)

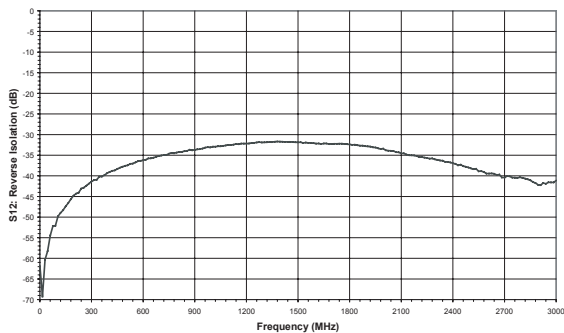

Figure 6: Output Return Loss (S22) vs. Frequency
(T_C = +25 °C, V_{DD} = +5 V)

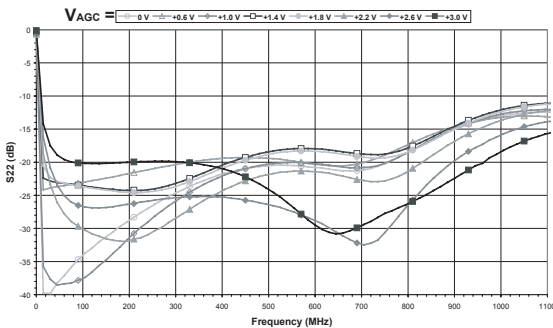

Figure 7: Noise Figure vs. Frequency
(T_C = +25 °C, V_{DD} = +5 V, V_{AGC} = +3 V)

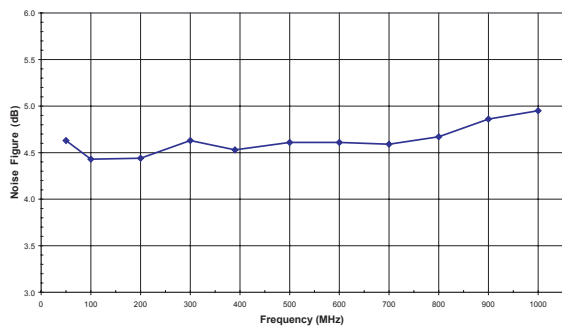

Figure 8: Gain vs. AGC Voltage
(T_C = +25 °C, V_{DD} = +5 V, at 495 MHz)

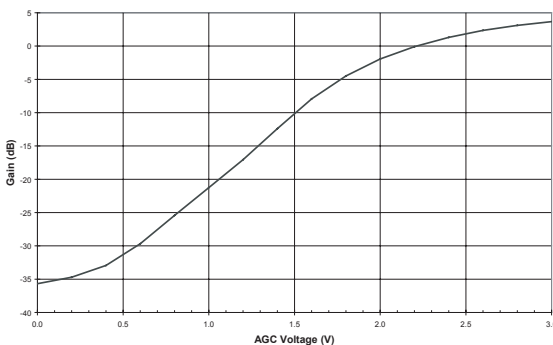

Figure 9: CTB vs. Frequency
 (T_C = +25 °C, V_{DD} = +5 V, 132 channels,
 +15 dBmV input, +6dBmV output)

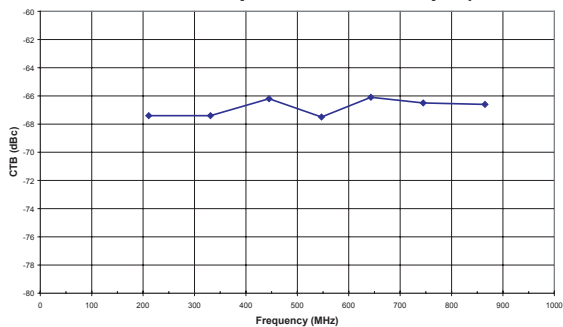

Figure 10 CSO vs. Frequency
 (T_C = +25 °C, V_{DD} = +5 V, 132 channels,
 +15 dBmV input, +6dBmV output)

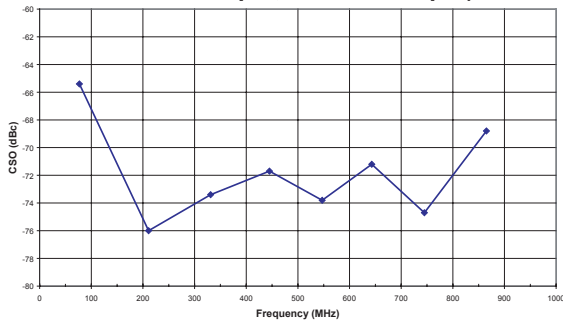

Figure 11: Gain Flatness at V_{AGC} = 0 V
 (T_C = +25 °C, V_{CC} = +5 V)

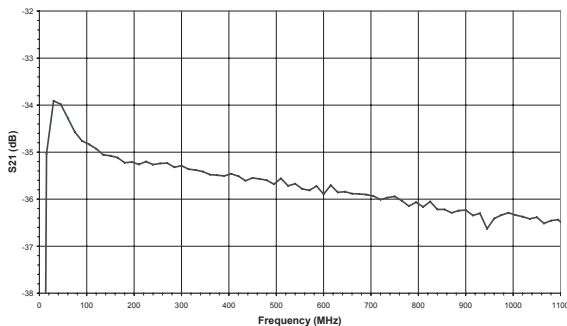
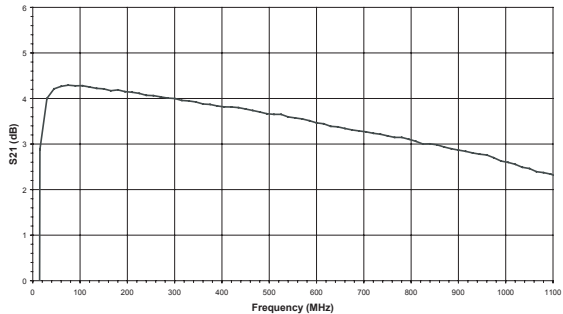

Figure 12: Gain Flatness at V_{AGC} = +3 V
 (T_C = +25 °C, V_{DD} = +5 V)



PERFORMANCE DATA - 50 Ω System

Figure 13: Gain (S21) vs. Frequency
(T_C = +25 °C, V_{DD} = +5 V)

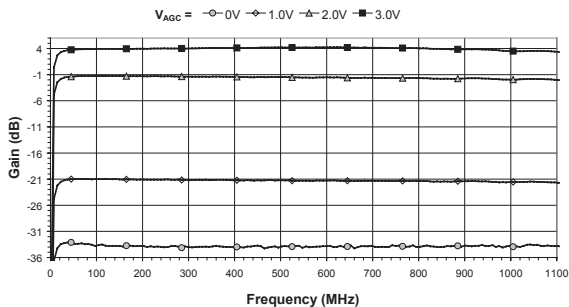

Figure 14: Input Return Loss (S11) vs. Frequency
(T_C = +25 °C, V_{DD} = +5 V)

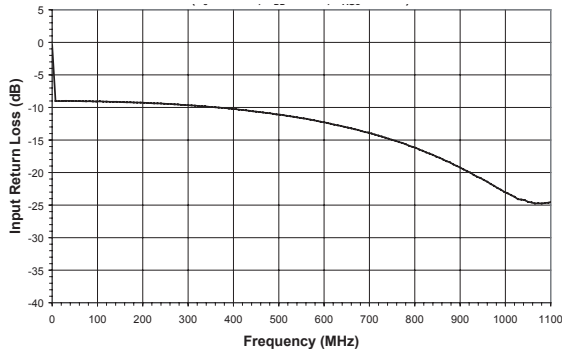

Figure 15: Reverse Isolation (S12) vs. Frequency
(T_C = +25 °C, V_{DD} = +5 V, V_{AGC} = +3 V)

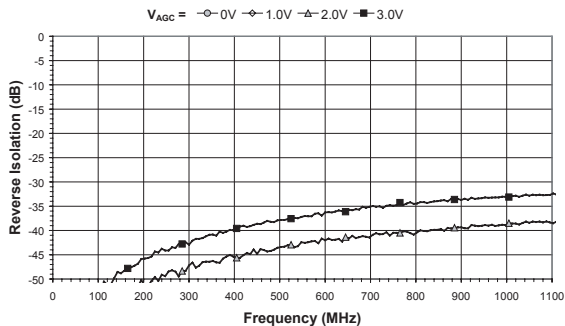

Figure 16: Output Return Loss (S22) vs. Frequency
(T_C = +25 °C, V_{DD} = +5 V)

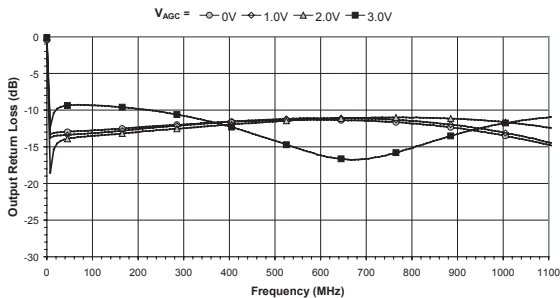
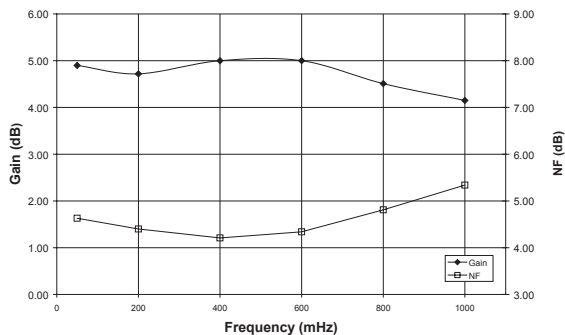

Figure 17: Gain and Noise Figure vs. Frequency
(V_{DD} = +5 V, V_{AGC} = +3 V, I_{DD} = 75mA)



Note:

50 Ω characterization is for reference only. Part is not tested at 50 Ω in production.

APPLICATION INFORMATION

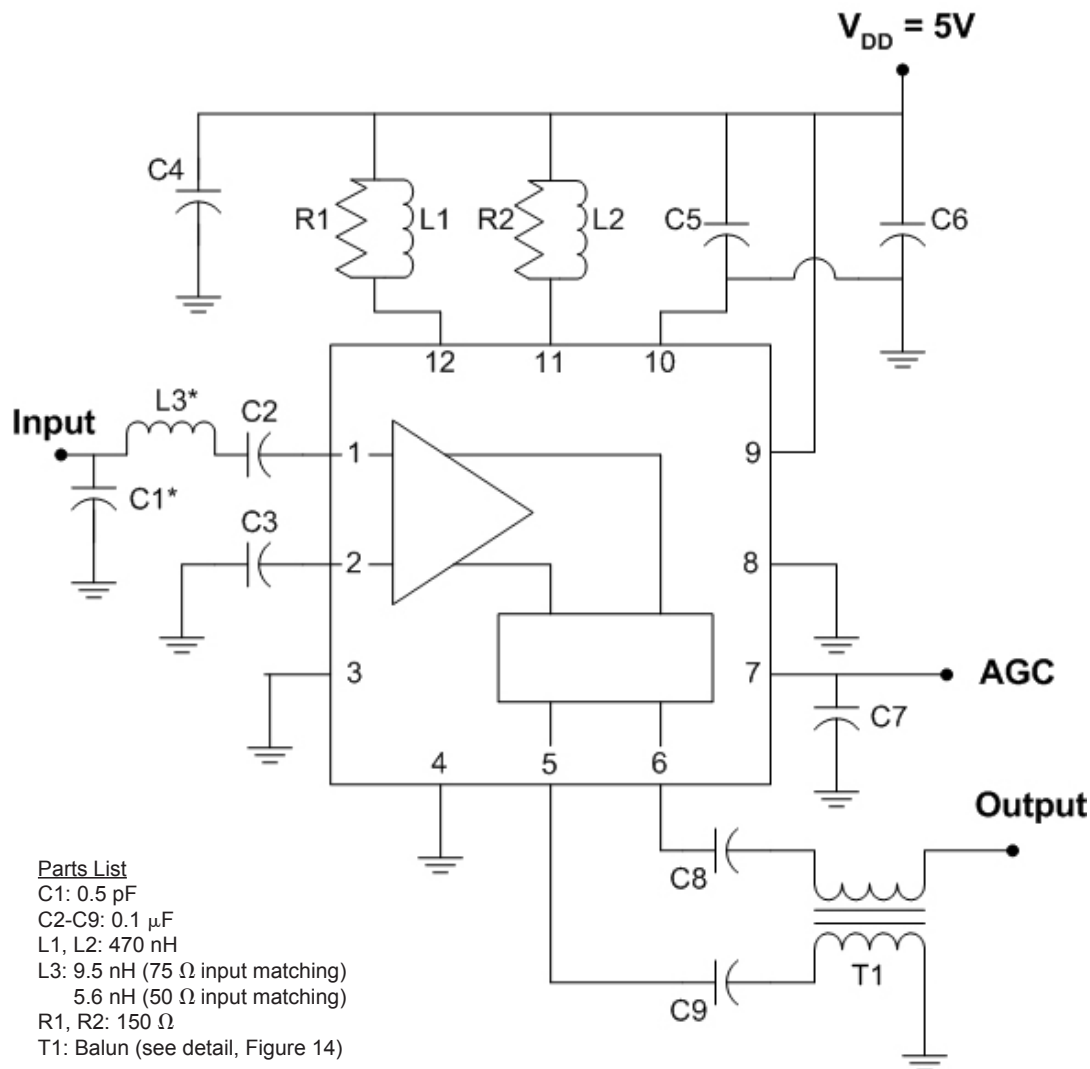

Figure 18: Test Circuit

*Note: C1 & L3 are required for matching to a 75 Ω low cost F connector at the RF Input. Higher quality connectors may not require such matching.

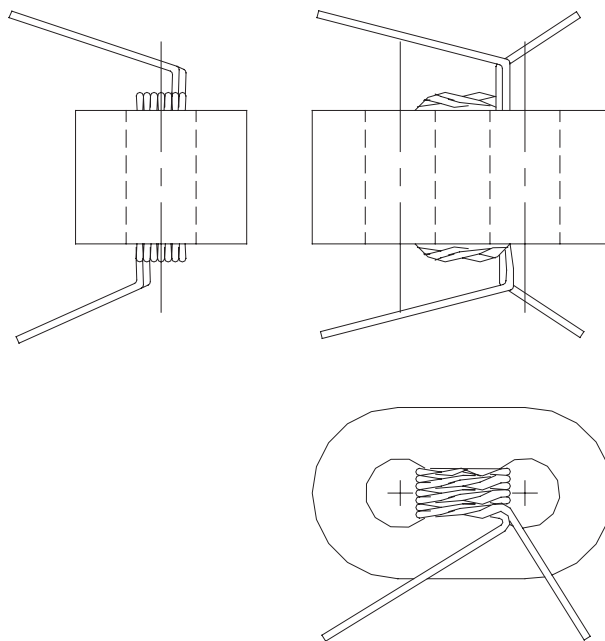

Figure 19: Balun Detail - 3.5 turn (P8002458)

Notes:

Ferrite core: FAIR-RITE #2843002702

Wire: MWS WIRE IND. #T-2361429-20

Balun Winding - 3 1/2 turns through core

PACKAGE OUTLINE

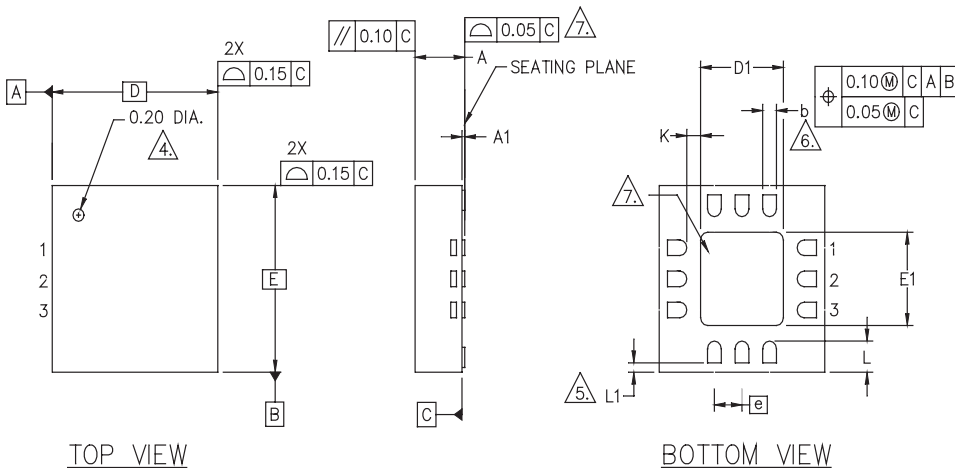
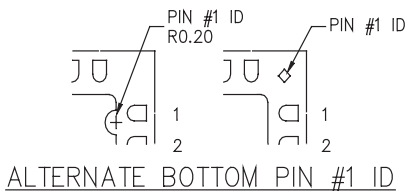

NOTES :

1. ALL DIMENSIONS ARE IN MILLIMETERS.
2. MAX. PACKAGE WARPAGE IS 0.05 mm.
3. MAXIMUM ALLOWABLE BURRS IS 0.076 mm IN ALL DIRECTIONS.
4. PIN #1 ID ON TOP WILL BE LASER MARKED.
5. A MAXIMUM 0.15mm PULL BACK (L1) MAYBE PRESENT. L MINUS L1 TO BE EQUAL TO OR GREATER THAN 0.30mm.
6. DIMENSION b APPLIES TO METALLIZED TERMINAL AND IS MEASURED BETWEEN 0.15 AND 0.30mm FROM TERMINAL TIP. IF THE TERMINAL HAS THE OPTIONAL RADIUS ON THE OTHER END OF THE TERMINAL, THE DIMENSION b SHOULD NOT BE MEASURED IN THAT RADIUS AREA.
7. BILATERAL COPLANARITY ZONE APPLIES TO THE EXPOSED HEAT SINK SLUG AS WELL AS THE TERMINALS.
8. REFERENCE JEDEC OUTLINE MO-220.

SYMBOL	DIMENSIONS—MM		SYMBOL	DIMENSIONS—INCHES	
	MIN.	MAX.		MIN.	MAX.
A	0.80	1.00	A	0.031	0.039
A1	0.00	0.05	A1	0.000	0.001
b	0.18	0.30	b	0.007	0.011
D	3.00 BSC		D	0.118 BSC	
D1	1.30	1.70	D1	0.051	0.067
E	3.00 BSC		E	0.118 BSC	
E1	1.30	1.70	E1	0.051	0.067
⌀	0.50 BSC		⌀	0.019 BSC	
K	0.20 MIN.		K	0.007 MIN.	
L	0.35	0.55	L	0.014	0.022
L1		0.15 MAX.	L1		0.006 MAX.

Figure 15: S26 Package Outline - 12 Pin 3 mm x 3 mm x 1 mm QFN

ORDERING INFORMATION

ORDER NUMBER	TEMPERATURE RANGE	PACKAGE DESCRIPTION	COMPONENT PACKAGING
ABA3130RS26Q1	-40 °C to +85 °C	RoHS Compliant 12 Pin 3 mm x 3 mm x 1 mm QFN Package	Tape and Reel, 1000 pieces per Reel

**ANADIGICS, Inc.**

141 Mount Bethel Road
Warren, New Jersey 07059, U.S.A.

Tel: +1 (908) 668-5000

Fax: +1 (908) 668-5132

URL: <http://www.anadigics.com>

IMPORTANT NOTICE

ANADIGICS, Inc. reserves the right to make changes to its products or to discontinue any product at any time without notice. The product specifications contained in Advanced Product Information sheets and Preliminary Data Sheets are subject to change prior to a product's formal introduction. Information in Data Sheets have been carefully checked and are assumed to be reliable; however, ANADIGICS assumes no responsibilities for inaccuracies. ANADIGICS strongly urges customers to verify that the information they are using is current before placing orders.

WARNING

ANADIGICS products are not intended for use in life support appliances, devices or systems. Use of an ANADIGICS product in any such application without written consent is prohibited.