



DATA SHEET

SEMICONDUCTOR

MMBZ52xxB Series

225 mW SOT-23

Zener Voltage Regulator Diodes

GENERAL DATA APPLICABLE TO ALL SERIES IN THIS GROUP

Zener Voltage Regulator Diodes



SOT-23 (TO-236AB)

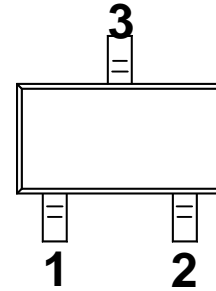

MAXIMUM CASE TEMPERATURE FOR SOLDERING

PURPOSES: 260°C for 10 seconds

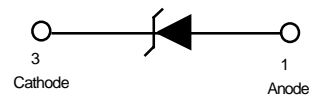

THERMAL CHARACTERISTICS

Characteristic	Symbol	Max	Unit
Total Device Dissipation FR-5 Board* T _A = 25°C	P _D	225	mW
Derate above 25°C		1.8	mW/°C
Thermal Resistance Junction to Ambient	R _{θJA}	556	°C/W
Total Device Dissipation Alumina Substrate,** T _A = 25°C	P _D	300	mW
Derate above 25°C		2.4	mW/°C
Thermal Resistance Junction to Ambient	R _{θJA}	417	°C/W
Junction and Storage Temperature	T _J , T _{stg}	150	°C

**FR-5 = 1.0 x 0.75 x 0.62 in.

**Alumina = 0.4 x 0.3 x 0.024 in. 99.5% alumina.

MMBZ52xxB Series

ELECTRICAL CHARACTERISTICS

(Pinout: 1-Anode, 2-NC, 3-Cathode) ($V_F = 0.9\text{ V Max @ } I_F = 10\text{ mA}$ for all types.)

Device	Marking	Test Current I_{ZT} mA	Zener Voltage VZ(+5%) Nominal (Note1)	Z_{Zk} $I_Z=0.25\text{mA}$ ΩMax	Z_{Zk} $I_Z=I_{ZT}@10\%\text{Mod}$ ΩMax	Max I_R μA	@	V_R V
MMBZ5221B	18A	20	2.4	1200	30	100		1
MMBZ5222B	18B	20	2.5	1250	30	100		1
MMBZ5223B	18C	20	2.7	1300	30	75		1
MMBZ5224B	18D	20	2.8	1400	30	75		1
MMBZ5225B	18E	20	3	1600	29	50		1
MMBZ5226B	8A	20	3.3	1600	28	25		1
MMBZ5227B	8B	20	3.6	1700	24	15		1
MMBZ5228B	8C	20	3.9	1900	23	10		1
MMBZ5229B	8D	20	4.3	2000	22	5		1
MMBZ5230B	8E	20	4.7	1900	19	5		2
MMBZ5231B	8F	20	5.1	1600	17	5		2
MMBZ5232B	8G	20	5.6	1600	11	5		3
MMBZ5233B	8H	20	6	1600	7	5		3.5
MMBZ5234B	8J	20	6.2	1000	7	5		4
MMBZ5235B	8K	20	6.8	750	5	3		5
MMBZ5236B	8L	20	7.5	500	6	3		6
MMBZ5237B	8M	20	8.2	500	8	3		6.5
MMBZ5238B	8N	20	8.7	600	8	3		6.5
MMBZ5239B	8P	20	9.1	600	10	3		7
MMBZ5240B	8Q	20	10	600	17	3		8
MMBZ5241B	8R	20	11	600	22	2		8.4
MMBZ5242B	8S	20	12	600	30	1		9.1
MMBZ5243B	8T	9.5	13	600	13	0.5		9.9
MMBZ5244B	8U	9	14	600	15	0.1		10
MMBZ5245B	8V	8.5	15	600	16	0.1		11
MMBZ5246B	8W	7.8	16	600	17	0.1		12
MMBZ5247B	8X	7.4	17	600	19	0.1		13
MMBZ5248B	8Y	7	18	600	21	0.1		14
MMBZ5249B	8Z	6.6	19	600	23	0.1		14
MMBZ5250B	81A	6.2	20	600	25	0.1		15
MMBZ5251B	81B	5.6	22	600	29	0.1		17
MMBZ5252B	81C	5.2	24	600	33	0.1		18
MMBZ5253B	81D	5	25	600	35	0.1		19
MMBZ5254B	81E	4.6	27	600	41	0.1		21
MMBZ5255B	81F	4.5	28	600	44	0.1		21
MMBZ5256B	81G	4.2	30	600	49	0.1		23
MMBZ5257B	81H	3.8	33	700	58	0.1		25
MMBZ5258B	81J	3.4	36	700	70	0.1		27
MMBZ5259B	81K	3.2	39	800	80	0.1		30
MMBZ5260B	18F	3	43	900	93	0.1		33
MMBZ5261B	81M	2.7	47	1000	105	0.1		36
MMBZ5262B	81N	2.5	51	1100	125	0.1		39
MMBZ5263B	81P	2.2	56	1300	150	0.1		43
MMBZ5264B	81Q	2.1	60	1400	170	0.1		46
MMBZ5265B	81R	2	62	1400	185	0.1		47
MMBZ5266B	81S	1.8	68	1600	230	0.1		52
MMBZ5267B	81T	1.7	75	1700	270	0.1		56
MMBZ5268B	81U	1.5	82	2000	330	0.1		62
MMBZ5269B	81V	1.4	87	2200	370	0.1		68
MMBZ5270B	81W	1.4	91	2300	400	0.1		69

NOTE 1. Zener voltage is measured with a pulse test current (I_{ZT}) applied at an ambient temperature of 25 °C

DEVICE CHARACTERISTICS

MMBZ52xxB Series

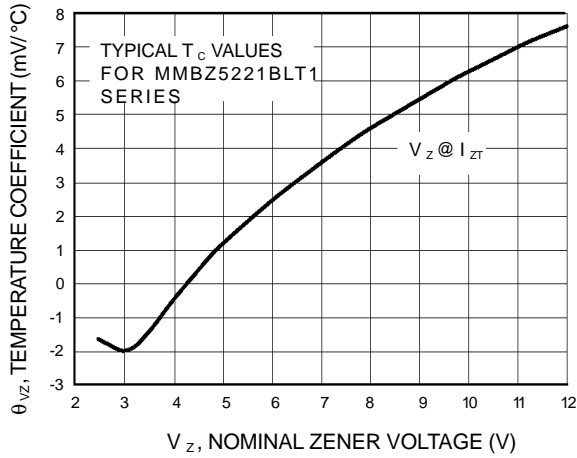

Figure 1. Temperature Coefficients
(Temperature Range -55°C to $+150^{\circ}\text{C}$)

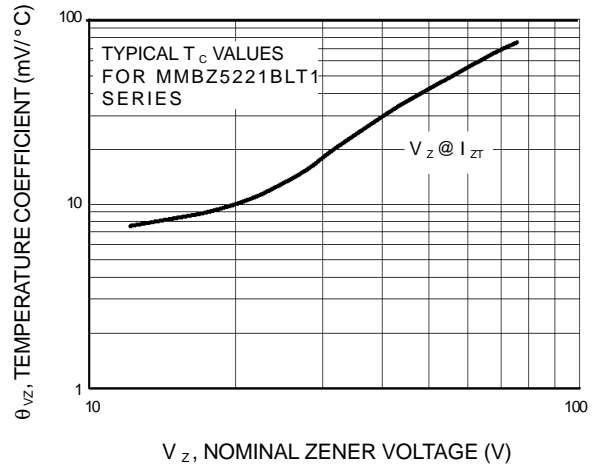

Figure 2. Temperature Coefficients
(Temperature Range -55°C to $+150^{\circ}\text{C}$)

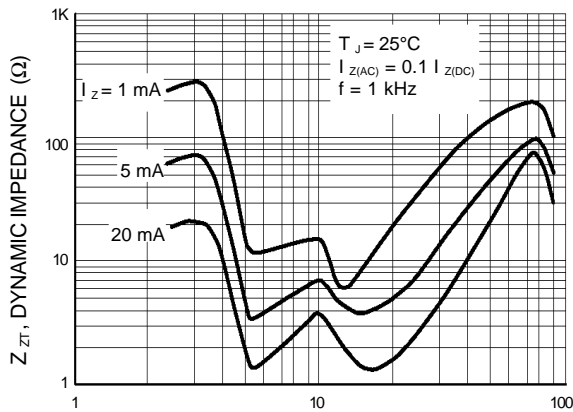

Figure 3. Effect of Zener Voltage on Zener Impedance

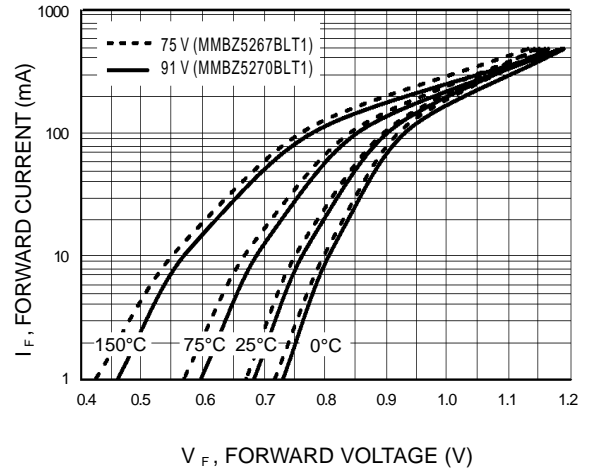
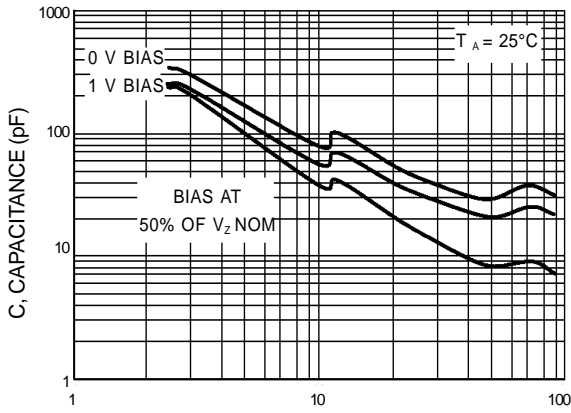

Figure 4. Typical Forward Voltage

DEVICE CHARACTERISTICS

MMBZ52xxB Series



V_Z , NOMINAL ZENER VOLTAGE (V)
Figure 5. Typical Capacitance

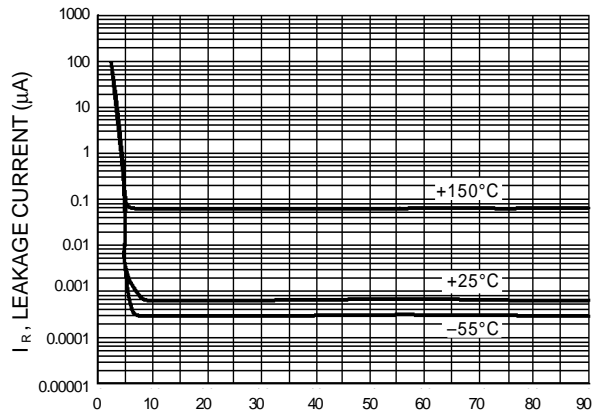

V_Z , NOMINAL ZENER VOLTAGE (V)
Figure 6. Typical Leakage Current

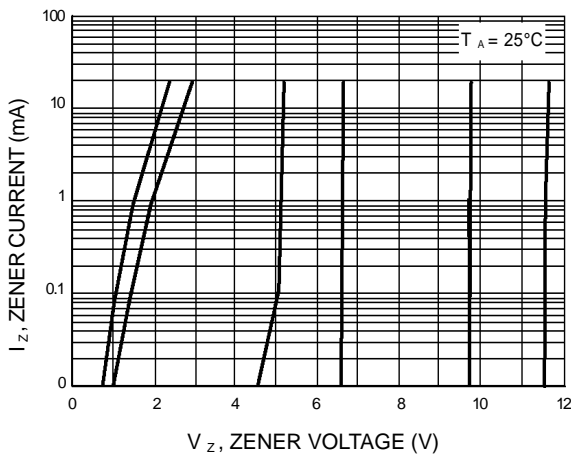

V_Z , ZENER VOLTAGE (V)
**Figure 7. Zener Voltage versus Zener Current
 (V_Z Up to 12 V)**

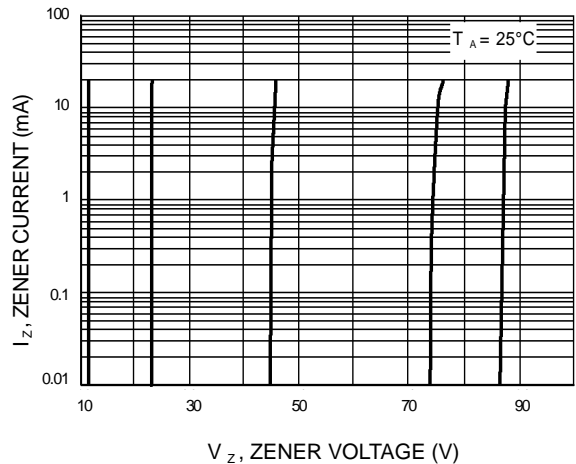

V_Z , ZENER VOLTAGE (V)
**Figure 8. Zener Voltage versus Zener Current
 (12 V to 91 V)**

PACKAGE OUTLINE & DIMENSIONS

MMBZ52xxB Series

NOTES:

1. DIMENSIONING AND TOLERANCING PER ANSI Y14.5M, 1982.
2. CONTROLLING DIMENSION: INCH.
3. MAXIMUM LEAD THICKNESS INCLUDES LEAD FINISH THICKNESS. MINIMUM LEAD THICKNESS IS THE MINIMUM THICKNESS OF BASE MATERIAL.

DIM	INCHES		MILLIMETERS	
	MIN	MAX	MIN	MAX
A	0.1102	0.1197	2.80	3.04
B	0.0472	0.0551	1.20	1.40
C	0.0350	0.0440	0.89	1.11
D	0.0150	0.0200	0.37	0.50
G	0.0701	0.0807	1.78	2.04
H	0.0005	0.0040	0.013	0.100
J	0.0034	0.0070	0.085	0.177
K	0.0180	0.0236	0.45	0.60
L	0.0350	0.0401	0.89	1.02
S	0.0830	0.0984	2.10	2.50
V	0.0177	0.0236	0.45	0.60

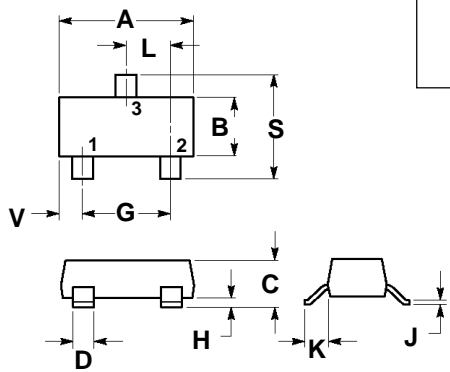

**CASE 318-07
PLASTIC**

STYLE 8:
PIN 1. ANODE
2. NO CONNECTION
3. CATHODE

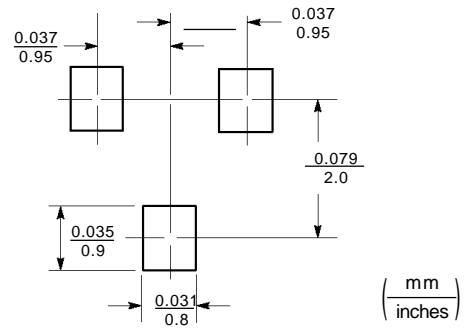

SOT-23 Footprint

(Refer to Section 10 for Surface Mount, Thermal Data and Footprint Information.)