



Model 1772 DWDM High Power CW Source Laser

The 1772 laser component is characterized for use as a CW optical source in CATV and DWDM networks. The 1772 is dc-coupled with a built-in TEC, thermistor, and monitor photodiode. The device is mounted in a 14-pin, OC-48 pinout compatible butterfly package with the optical isolator mounted on the TEC. The 1772 incorporates a high efficiency coupling scheme to deliver 40 mW, 50 mW, and 63 mW of CW optical power.

Applications

- DWDM
- CATV
- Free space optics

Features

- 40, 50, 63 mW optical output power
- OC-48 pinout compatible
- *Telcordia Technologies™* GR-468 compliant
- PM fiber
- -20°C to +65°C operating temperature range
- Monitor photodiode

Performance Highlights

Parameter	Min	Typ	Max	Units
Operating Case Temperature	-20	25	+65	°C
Wavelength	See Page 4			nm
Optical Output Power	40	-	-	mW
	50	-	-	
	63	-	-	
Threshold Current	-	-	40	mA
Operating Current	-	-	380	mA
RIN	-	-	-163	dB/Hz
RIN Through 65 km Fiber	-	-	-155	dB/Hz
SMSR	30	-	-	dB
Polarization Extinction Ratio (PMF pigtail)	17	-	-	dB
Optical Isolation	32	-	-	dB
Optical Return Loss	40	-	-	dB

See page 2 for specific test conditions.



For more information on this and other products:

Contact Sales at Emcore 626-293-3400, or visit www.emcore.com.

Absolute Maximum Ratings

Stresses in excess of the absolute maximum ratings can cause permanent damage to the device. These are absolute stress ratings only. Functional operation of the device is not implied at these or any other conditions in excess of those given in the operational sections of the data sheet. Exposure to absolute maximum ratings for extended periods can adversely affect device reliability.

Parameter	Symbol	Condition	Min	Max	Units
Operating Case Temperature	T_{OP}	continuous	-20	+65	°C
Storage Temperature	T_{STG}	continuous	-40	+85	°C
Laser Forward dc Current	-	continuous	-	450	mA
Photodiode Reverse Voltage	$V_{R,MPD}$	continuous	-	10	V
Laser Reverse Voltage	-	continuous	-	2	V
TEC current	I_{TEC}	continuous	-	1.7	A
ESD	-	HBM: R = 1500 Ω , C = 100 pF	-500	500	V

Electrical/Optical Characteristics

Parameter	Symbol	Condition	Min	Typ	Max	Unit
Operating Case Temperature ¹	T_{OP}	-	-20	25	65	°C
Optical Output Power	P_O	40 mW version, $T = T_{set}, I_F = I_{OP}$ 50 mW version, $T = T_{set}, I_F = I_{OP}$ 63 mW version, $T = T_{set}, I_F = I_{OP}$	40 50 63	- - -	- - -	mW
Threshold Current	I_{TH}	BOL	-	-	40	mA
Operating Current	I_{OP}	40 mW version, BOL 50 mW version, BOL 63 mW version, BOL	- - -	- - -	330 380 380	mA
Laser Bias Forward Voltage	V_{OP}	BOL, $I_F = I_{OP}$	-	-	2.5	V
Wavelength	λ_{OP}	$T = T_{set}, I_F = I_{OP}$	See Page 4			nm
Spectral Linewidth	$\Delta\lambda$	$T = T_{set}, I_F = I_{OP}$, FWHM	-	-	1.0	MHz
Optical Isolation	ISO	-	32	-	-	dB
Optical Return Loss	ORL	-	40	-	-	dB
Sidemode Suppression Ratio	SMSR	-	30	-	-	dB
Polarization Extinction Ratio	PER	$I_F = I_{OP}$	17	-	-	dB
Wavelength Drift Over T_C Range	$\Delta\lambda_{TOP}$	$T = T_{OP}$	-	-	40	pm
Relative Intensity Noise	RIN	-	-	-	-163	dB/Hz
Monitor PD Current	I_{MPD}	$I_F = I_{OP}, V_{MPD} = -5 V$	100	-	2500	μA
Monitor PD Dark Current	I_D	$I_{OP} = 0 mA, V_{MPD} = -5 V$	-	-	0.2	μA
Thermistor Resistance	R_{TH}	$T_{OP} = 25\text{ }^\circ C$	9.5	10.0	10.5	$K\Omega$
Thermistor Temp. Coefficients	TC_{TH}	$T_{OP} = 25\text{ }^\circ C$	-	-4.4	-	%/ $^\circ C$
TEC Current	I_{TEC}	$-20\text{ }^\circ C < T_C < +65\text{ }^\circ C$	-1.0	-	+1.5	A
TEC Voltage	V_{TEC}	$-20\text{ }^\circ C < T_C < +65\text{ }^\circ C$	-2.0	-	+3.0	V

Outline Drawing

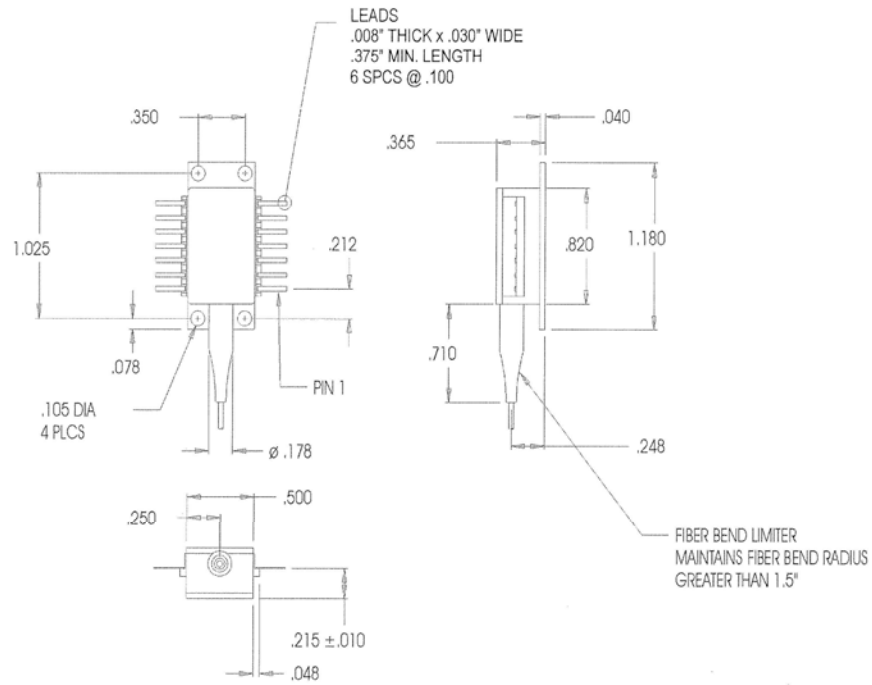

Pin Assignments

Pin	Function
1	Thermistor
2	Thermistor
3	Laser DC Bias (-)
4	MPD Anode
5	MPD Cathode
6	TEC (+, current in cools)
7	TEC (-)
8	Case Ground
9	Case Ground
10	No Connection
11	Laser Common (+)
12	Laser Modulation (-)
13	Laser Common (+)
14	No Connection

ITU Grid Channel Numbering

Please contact Emcore Sales for ITU wavelength channel availability.

Package Schematic

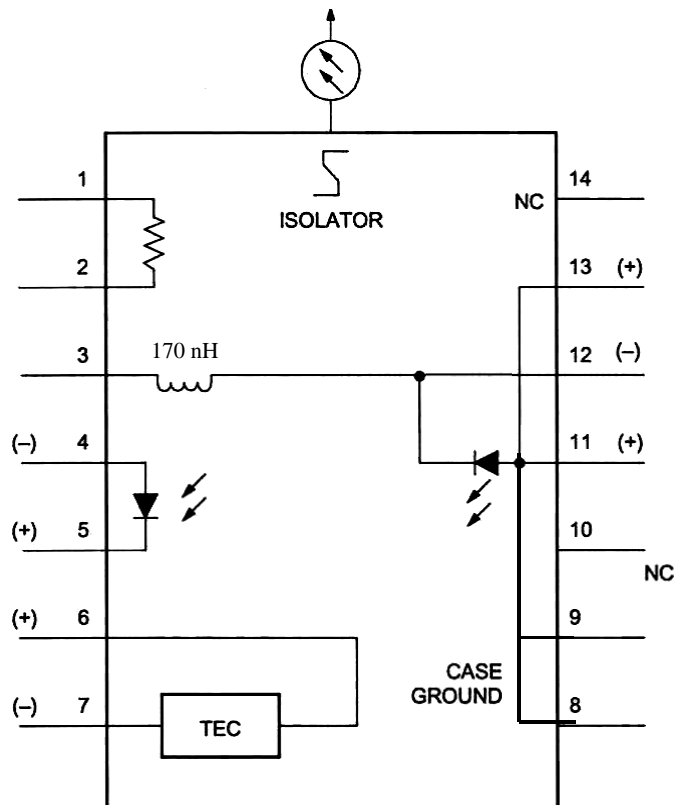

Laser Safety

Class IIIb Laser Product

This product meets the appropriate standard in Title 21 of the Code of Federal Regulations (CFR). FDA/CDRH Class IIIb laser product. This device has been classified with the FDA/CDRH under accession number 0220732.

Single-mode fiber pigtail with FC/APC connectors (standard).

Wavelength = 1.5 μm .

Maximum power = 100 mW.

Because of size constraints, laser safety labeling (including an FDA class IIIb label) is not affixed to the module, but attached to the outside of the shipping carton.

Product is not shipped with power supply.

Caution: Use of controls, adjustments and procedures other than those specified herein may result in hazardous laser radiation exposure.

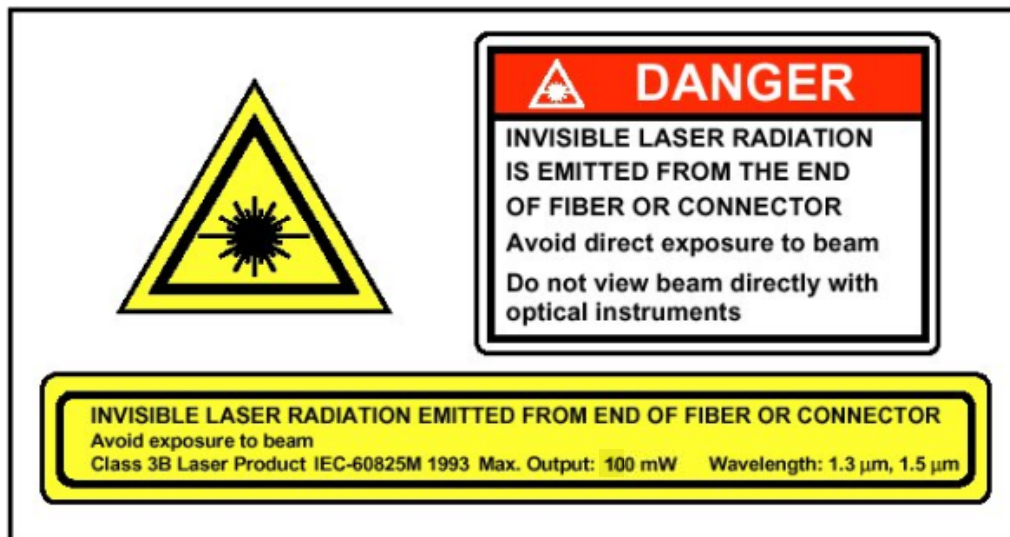

Ordering Code Definitions

1772-NM-xx-yy-FC-PM

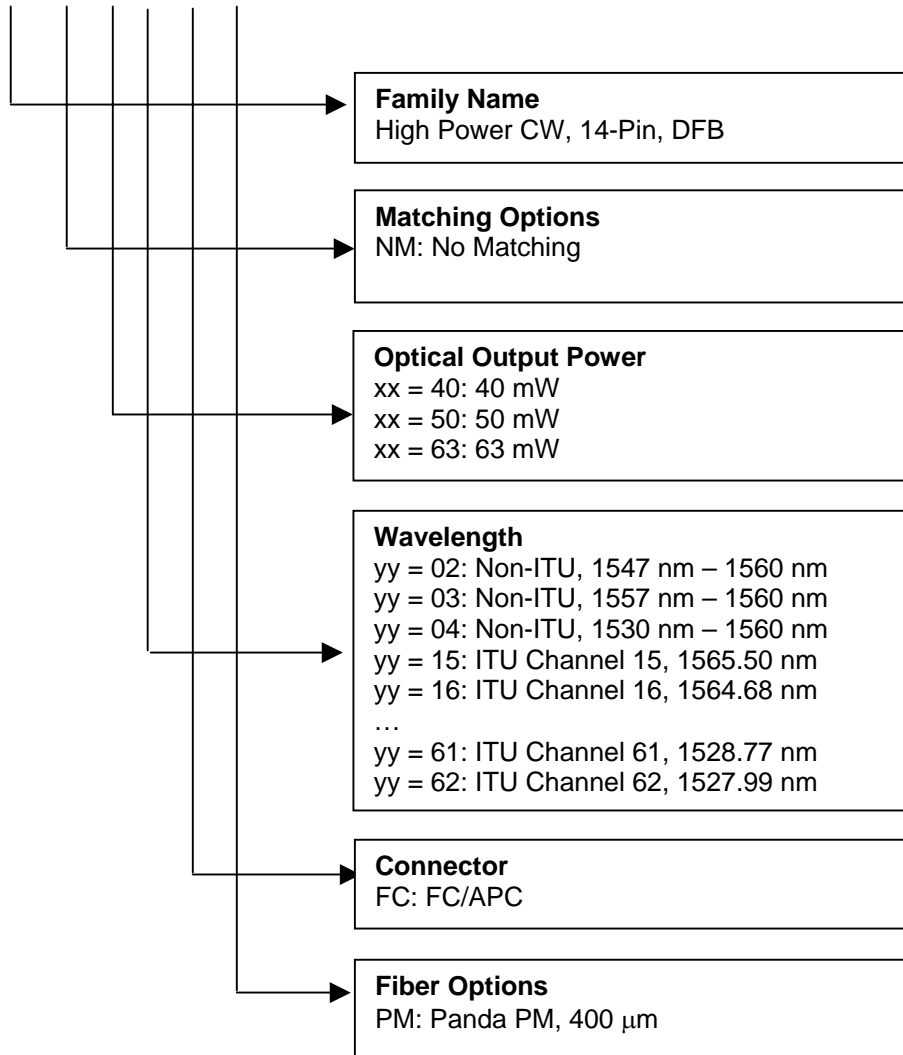

Example

1772-NM-63-43-FC-PM: 1772, 63 mW minimum output power, ITU channel 43, 1542.94 nm, FC/APC, Panda PM, 400 micron buffer. Please contact Emcore Sales for current ITU wavelength channel availability.

Information contained herein is deemed to be reliable and accurate as of issue date. EMCORE reserves the right to change the design or specifications of the product at any time without notice. EMCORE and the EMCORE logo are trademarks of EMCORE Corporation.

