

## Small Signal Schottky Diodes, Single & Dual

### Features

- These diodes feature very low turn-on voltage and fast switching
- These devices are protected by a PN junction guard ring against excessive voltage, such as electrostatic discharges
- AEC-Q101 qualified
- Compliant to RoHS directive 2002/95/EC and in accordance to WEEE 2002/96/EC



**RoHS**  
COMPLIANT

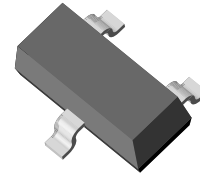

### Mechanical Data

**Case:** SOT-23

**Weight:** approx. 8.8 mg

#### Packaging Codes/Options:

GS18 / 10 k per 13" reel (8 mm tape), 10 k/box

GS08 / 3 k per 7" reel (8 mm tape), 15 k/box

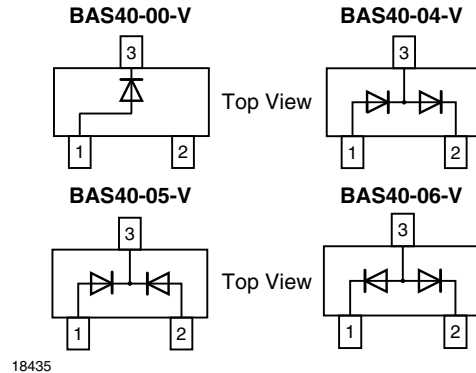

### Parts Table

Part	Ordering code	Type Marking	Remarks
BAS40-00-V	BAS40-00-V-GS18 or BAS40-00-V-GS08	43	Tape and Reel
BAS40-04-V	BAS40-04-V-GS18 or BAS40-04-V-GS08	44	Tape and Reel
BAS40-05-V	BAS40-05-V-GS18 or BAS40-05-V-GS08	45	Tape and Reel
BAS40-06-V	BAS40-06-V-GS18 or BAS40-06-V-GS08	46	Tape and Reel

### Absolute Maximum Ratings

$T_{amb} = 25\text{ }^{\circ}\text{C}$ , unless otherwise specified

Parameter	Test condition	Symbol	Value	Unit
Repetitive peak reverse voltage		$V_{RRM} = V_{RWM} = V_R$	40	V
Forward continuous current		$I_F$	200 <sup>1)</sup>	mA
Surge forward current	$t_p < 1\text{ s}$	$I_{FSM}$	600 <sup>1)</sup>	mA
Power dissipation <sup>1)</sup>		$P_{tot}$	200 <sup>1)</sup>	mW

<sup>1)</sup> Device on fiberglass substrate, see layout on next page.

### Thermal Characteristics

$T_{amb} = 25\text{ }^{\circ}\text{C}$ , unless otherwise specified

Parameter	Test condition	Symbol	Value	Unit
Thermal resistance junction to ambient air		$R_{thJA}$	500 <sup>1)</sup>	K/W
Junction temperature		$T_j$	125	$^{\circ}\text{C}$
Storage temperature range		$T_{stg}$	- 65 to + 150	$^{\circ}\text{C}$

<sup>1)</sup> Device on fiberglass substrate, see layout on next page.

### Electrical Characteristics

$T_{amb} = 25\text{ }^{\circ}\text{C}$ , unless otherwise specified

Parameter	Test condition	Symbol	Min	Typ.	Max	Unit
Reverse breakdown voltage	$I_R = 10\text{ }\mu\text{A}$ (pulsed)	$V_{(BR)}$	40			V
Leakage current	Pulse test $V_R = 30\text{ V}$ , $t_p < 300\text{ }\mu\text{s}$	$I_R$		20	100	nA
Forward voltage	Pulse test $t_p < 300\text{ }\mu\text{s}$ , $I_F = 1\text{ mA}$	$V_F$			380	mV
	Pulse test $t_p < 300\text{ }\mu\text{s}$ , $I_F = 40\text{ mA}$	$V_F$			1000	mV
Diode capacitance	$V_R = 0\text{ V}$ , $f = 1\text{ MHz}$	$C_D$		4	5	pF
Reverse recovery time	$I_F = I_R = 10\text{ mA}$ , $i_R = 1\text{ mA}$ , $R_L = 100\text{ }\Omega$	$t_{rr}$			5	ns

### Layout for $R_{thJA}$ test

Thickness:

Fiberglass 1.5 mm (0.059 in.)

Copper leads 0.3 mm (0.012 in.)

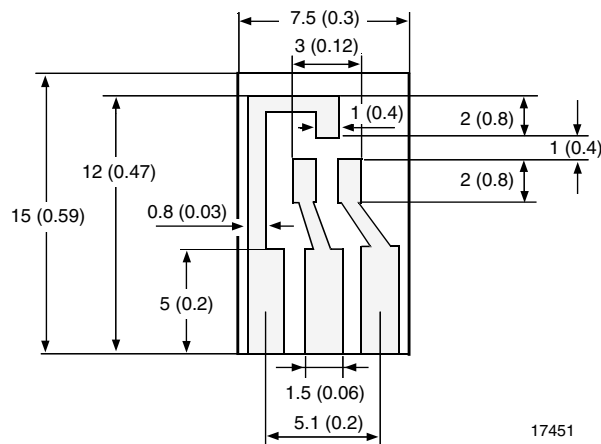

17451

## Package Dimensions in millimeters (inches): SOT-23

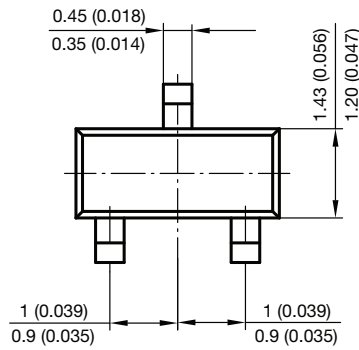
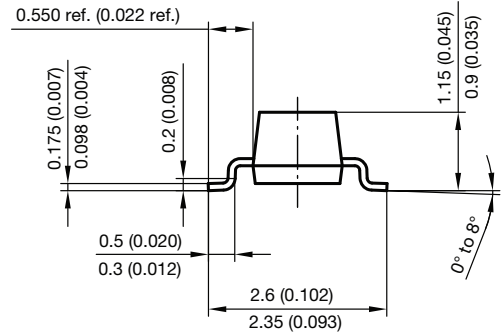
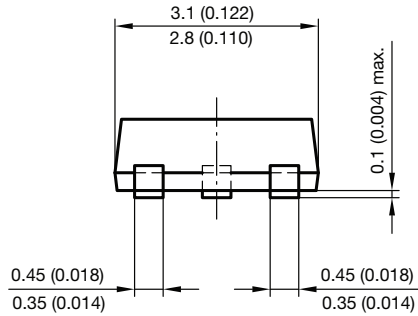

Foot print recommendation:

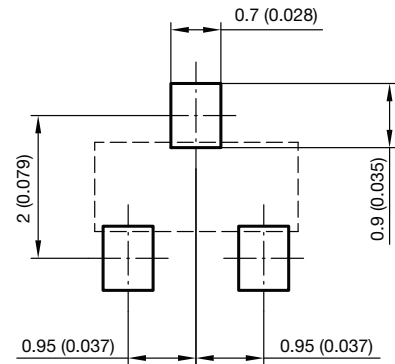

Document no.: 6.541-5014.01-4

Rev. 8 - Date: 23.Sept.2009

17418



### Disclaimer

All product specifications and data are subject to change without notice.

Vishay Intertechnology, Inc., its affiliates, agents, and employees, and all persons acting on its or their behalf (collectively, "Vishay"), disclaim any and all liability for any errors, inaccuracies or incompleteness contained herein or in any other disclosure relating to any product.

Vishay disclaims any and all liability arising out of the use or application of any product described herein or of any information provided herein to the maximum extent permitted by law. The product specifications do not expand or otherwise modify Vishay's terms and conditions of purchase, including but not limited to the warranty expressed therein, which apply to these products.

No license, express or implied, by estoppel or otherwise, to any intellectual property rights is granted by this document or by any conduct of Vishay.

The products shown herein are not designed for use in medical, life-saving, or life-sustaining applications unless otherwise expressly indicated. Customers using or selling Vishay products not expressly indicated for use in such applications do so entirely at their own risk and agree to fully indemnify Vishay for any damages arising or resulting from such use or sale. Please contact authorized Vishay personnel to obtain written terms and conditions regarding products designed for such applications.

Product names and markings noted herein may be trademarks of their respective owners.