

Type 3632 Series

Type 3632 Series

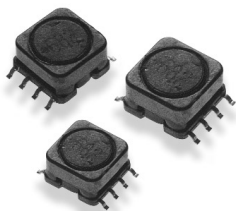

The 3632 series offers a range of high current shielded inductors suitable for a broad range of Industrial applications. The low profile package makes this product very effective in space – conscious applications and designs. These inductors are frequently chosen for new applications in Power Supply design.

Key Features

- Wide value range up to 15000uH
- Ferrite Core
- Up to 5.6A
- Taped and Reeled
- High reliability
- Ferrite Core

Electrical Characteristics - 3632A Series

Inductance Code	Inductance (µH)	Tolerance	Q Ref.	Test Freq. (Hz)		S.R.F. (MHz) Typ.	R.D.C. (Ω) Max.	I.D.C. (A) Max.
				L	Q			
2R7	2.7	±20%	23	1K	7.960M	85.00	0.032	3.20
3R5	3.5	±20%	23	1K	7.960M	80.00	0.036	2.90
4R7	4.7	±20%	23	1K	7.960M	70.00	0.040	2.70
5R6	5.6	±20%	23	1K	7.960M	57.00	0.046	2.50
6R8	6.8	±20%	23	1K	7.960M	38.00	0.050	2.30
8R2	8.2	±20%	23	1K	7.960M	30.00	0.055	2.10
100	10.0	±20%	35	1K	2.520M	29.00	0.080	1.80
120	12.0	±20%	35	1K	2.520M	26.00	0.085	1.70
150	15.0	±20%	35	1K	2.520M	29.00	0.100	1.60
180	18.0	±20%	35	1K	2.520M	22.00	0.110	1.50
220	22.0	±20%	35	1K	2.520M	19.00	0.130	1.40
270	27.0	±20%	35	1K	2.520M	17.00	0.140	1.30
330	33.0	±20%	35	1K	2.520M	15.00	0.150	1.20
390	39.0	±20%	35	1K	2.520M	14.00	0.160	1.10
470	47.0	±20%	35	1K	2.520M	12.00	0.180	1.00
560	56.0	±20%	35	1K	2.520M	12.00	0.300	0.93
680	68.0	±20%	40	1K	2.520M	9.00	0.350	0.85
820	82.0	±20%	40	1K	2.520M	8.00	0.370	0.78
101	100	±15%	40	1K	0.796M	7.50	0.420	0.70
121	120	±15%	40	1K	0.796M	7.00	0.480	0.65
151	150	±15%	40	1K	0.796M	6.00	0.550	0.60
181	180	±15%	40	1K	0.796M	5.50	0.820	0.52
221	220	±15%	40	1K	0.796M	5.00	1.000	0.48
271	270	±15%	40	1K	0.796M	5.00	1.100	0.44
331	330	±15%	40	1K	0.796M	4.50	1.300	0.40
391	390	±15%	40	1K	0.796M	4.20	1.400	0.38
471	470	±15%	40	1K	0.796M	4.00	1.600	0.35
561	560	±15%	60	1K	0.796M	3.20	2.700	0.28
681	680	±15%	60	1K	0.796M	2.70	3.200	0.25
821	820	±15%	85	1K	0.796M	2.60	3.500	0.23
102	1000	±15%	100	1K	0.252M	2.30	4.000	0.22
122	1200	±15%	100	1K	0.252M	2.30	4.400	0.20
152	1500	±15%	100	1K	0.252M	2.00	5.200	0.18
182	1800	±15%	100	1K	0.252M	1.70	7.000	0.17
222	2200	±15%	100	1K	0.252M	1.50	8.500	0.16
272	2700	±15%	100	1K	0.252M	1.40	9.200	0.14
332	3300	±15%	100	1K	0.252M	1.30	11.000	0.12
392	3900	±15%	100	1K	0.252M	1.20	16.000	0.11
472	4700	±15%	100	1K	0.252M	1.00	19.000	0.10
562	5600	±15%	100	1K	0.252M	0.90	21.000	0.09
682	6800	±15%	100	1K	0.252M	0.90	24.000	0.09
822	8200	±15%	100	1K	0.252M	0.80	31.000	0.08
103	10000	±15%	100	1K	79.60K	0.70	38.000	0.07

Type 3632 Series

**Electrical Characteristics -
3632B Series**

Inductance Code	Inductance (µH)	Tolerance	Q Ref.	Test Freq. (Hz)		S.R.F. (MHz) Typ.	R.D.C. (Ω) Max.	I.D.C. (A) Max.
				L	Q			
1R5	1.50	±20%	20	1K	7.960M	65.00	0.014	5.600
2R7	2.70	±20%	20	1K	7.960M	50.00	0.019	4.800
3R9	3.90	±20%	20	1K	7.960M	35.00	0.021	4.400
5R6	5.60	±20%	18	1K	7.960M	25.00	0.027	3.800
7R5	7.50	±20%	18	1K	7.960M	15.00	0.032	3.400
100	10.0	±20%	33	1K	2.520M	11.00	0.040	3.000
120	12.0	±20%	40	1K	2.520M	11.00	0.050	2.500
150	15.0	±20%	45	1K	2.520M	8.50	0.065	2.200
180	18.0	±20%	40	1K	2.520M	8.50	0.075	2.000
220	22.0	±20%	35	1K	2.520M	6.00	0.080	1.900
270	27.0	±20%	45	1K	2.520M	6.00	0.090	1.800
330	33.0	±20%	40	1K	2.520M	5.00	0.100	1.700
390	39.0	±20%	45	1K	2.520M	5.00	0.135	1.500
470	47.0	±20%	40	1K	2.520M	4.00	0.150	1.400
560	56.0	±20%	35	1K	2.520M	3.00	0.165	1.350
680	68.0	±20%	30	1K	2.520M	2.50	0.184	1.250
820	82.0	±20%	30	1K	2.520M	2.40	0.260	1.050
101	100	±15%	40	1K	0.796M	6.00	0.280	1.000
121	120	±15%	42	1K	0.796M	5.70	0.340	0.900
151	150	±15%	45	1K	0.796M	4.60	0.450	0.800
181	180	±15%	35	1K	0.796M	4.20	0.500	0.700
221	220	±15%	30	1K	0.796M	3.80	0.600	0.650
271	270	±15%	30	1K	0.796M	3.40	0.700	0.600
331	330	±15%	30	1K	0.796M	3.00	0.800	0.550
391	390	±15%	33	1K	0.796M	2.60	1.000	0.500
471	470	±15%	30	1K	0.796M	2.30	1.150	0.450
561	560	±15%	35	1K	0.796M	2.20	1.500	0.380
681	680	±15%	30	1K	0.796M	2.00	1.700	0.350
821	820	±15%	35	1K	0.796M	1.90	2.200	0.320
102	1000	±15%	80	1K	0.252M	1.80	2.500	0.300
152	1500	±15%	120	1K	0.252M	1.30	4.000	0.250
222	2200	±15%	95	1K	0.252M	1.00	5.000	0.200
332	3300	±15%	95	1K	0.252M	0.90	8.000	0.150
472	4700	±15%	90	1K	0.252M	0.80	12.000	0.120
682	6800	±15%	90	1K	0.252M	0.60	16.500	0.100
822	8200	±15%	85	1K	0.252M	0.50	24.000	0.097
103	10000	±15%	110	1K	79.60K	0.50	26.000	0.095
153	15000	±15%	130	1K	79.60K	0.40	40.000	0.075

Environmental Characteristics -

Storage Temp:	-40°C to +125°C
Operating Temp:	-25°C to +105°C
Rated Current:	Based on temp. rise & $\Delta L/L=10\%$ max.
Temp. Rise:	40°C max.

Type 3632 Series

Dimensions

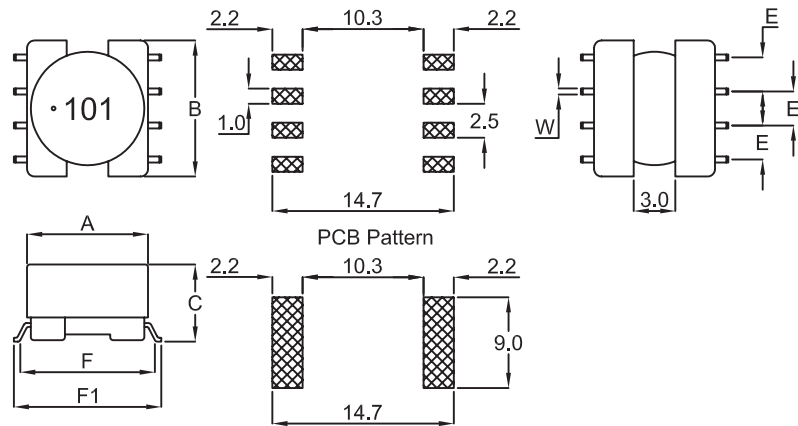

Series	A ±0.3	B nom.	C ±0.3	E ±0.3	F ±0.5	F1 ±0.8	W ±0.1
3632A	9.5	10.5	6.0	2.5	11.0	12.7	0.7
3632B	9.5	10.5	7.5	2.5	11.0	12.7	0.7

How to Order

3632	A	1R5	M
Common Part	Style	Inductance	Tolerance
3632	A or B	See Relevant Table for Inductance Code	L - ±15% M - 20%