

# DATA SHEET



## **SAA7111** Video Input Processor (VIP)

Product specification  
Supersedes data of 1996 Oct 30  
File under Integrated Circuits, IC22

1998 May 15

## Video Input Processor (VIP)

SAA7111

<b>CONTENTS</b>		
1	FEATURES	
2	APPLICATIONS	
3	GENERAL DESCRIPTION	
4	QUICK REFERENCE DATA	
5	ORDERING INFORMATION	
6	BLOCK DIAGRAM	
7	PINNING	
8	FUNCTIONAL DESCRIPTION	
8.1	Analog input processing	16.2.10 Subaddress 0A
8.2	Analog control circuits	16.2.11 Subaddress 0B
8.2.1	Clamping	16.2.12 Subaddress 0C
8.2.2	Gain control	16.2.13 Subaddress 0D
8.3	Chrominance processing	16.2.14 Subaddress 0E
8.4	Luminance processing	16.2.15 Subaddress 10
8.5	RGB matrix	16.2.16 Subaddress 11
8.6	VPO-bus (digital outputs)	16.2.17 Subaddress 12
8.7	Synchronization	16.2.18 Subaddress 1A (read-only register)
8.8	Clock generation circuit	16.2.19 Subaddress 1B (read-only register)
8.9	Power-on reset and CE input	16.2.20 Subaddress 1C (read-only register)
8.10	RTCO output	16.2.21 Subaddress 1F (read-only register)
8.11	The Line-21 text slicer	
8.11.1	Suggestions for I <sup>2</sup> C-bus interface of the display software reading line-21 data	17 FILTER CURVES
9	GAIN CHARTS	17.1 Anti-alias filter curve
10	LIMITING VALUES	17.2 Luminance filter curves
11	CHARACTERISTICS	17.3 Chrominance filter curves
12	TIMING DIAGRAMS	18 I <sup>2</sup> C START SET-UP
13	CLOCK SYSTEM	19 PACKAGE OUTLINE
13.1	Clock generation circuit	20 SOLDERING
13.2	Power-on control	20.1 Introduction
14	OUTPUT FORMATS	20.2 Reflow soldering
15	APPLICATION INFORMATION	20.3 Wave soldering
15.1	Layout hints	20.3.1 PLCC
16	I <sup>2</sup> C-BUS DESCRIPTION	20.3.2 QFP
16.1	I <sup>2</sup> C-bus format	20.3.3 Method (PLCC and QFP)
16.2	I <sup>2</sup> C-bus detail	20.4 Repairing soldered joints
16.2.1	Subaddress 00	21 DEFINITIONS
16.2.2	Subaddress 02	22 LIFE SUPPORT APPLICATIONS
16.2.3	Subaddress 03	23 PURCHASE OF PHILIPS I <sup>2</sup> C COMPONENTS
16.2.4	Subaddress 04	
16.2.5	Subaddress 05	
16.2.6	Subaddress 06	
16.2.7	Subaddress 07	
16.2.8	Subaddress 08	
16.2.9	Subaddress 09	

# Video Input Processor (VIP)

# SAA7111

## 1 FEATURES

- Four analog inputs, internal analog source selectors, e.g.  $4 \times$  CVBS or  $2 \times$  Y/C or ( $1 \times$  Y/C and  $2 \times$  CVBS)
- Two analog preprocessing channels
- Fully programmable static gain for the main channels or automatic gain control for the selected CVBS or Y/C channel
- Switchable white peak control
- Two built-in analog anti-aliasing filters
- Two 8-bit video CMOS analog-to-digital converters (ADCs)
- On-chip clock generator
- Line-locked system clock frequencies
- Digital PLL for H-sync processing and clock generation
- Requires only one crystal (24.576 MHz) for all standards
- Horizontal and vertical sync detection
- Automatic detection of 50/60 Hz field frequency and automatic switching between standards PAL and NTSC
- Luminance and chrominance signal processing for PAL BGHI, PAL N, PAL M, NTSC M, NTSC N and NTSC 4.43
- User programmable luminance peaking or aperture correction
- Cross-colour reduction for NTSC by chrominance comb filtering
- PAL delay line for correcting PAL phase errors
- Real time status information output (RTCO)
- Brightness Contrast Saturation (BCS) control on-chip
- The YUV (CCIR-601) bus supports a data rate of:
  - $864 \times f_H = 13.5$  MHz for 625 line sources
  - $858 \times f_H = 13.5$  MHz for 525 line sources.
- Data output streams for 16, 12 or 8-bit width with the following formats:
  - 411 YUV (12-bit)
  - 422 YUV (16-bit)
  - 422 YUV [CCIR-656] (8-bit)
  - 565 RGB (16-bit) with dither
  - 888 RGB (24-bit) with special application.
- 720 active samples per line on the YUV bus
- One user programmable general purpose switch on an output pin
- Built in line-21 text slicer
- Power-on control



- Two switchable outputs for the digitized CVBS or Y/C input signals AD1 (7 to 0) and AD2 (7 to 0) via the I<sup>2</sup>C-bus
- Chip enable function (reset for the clock generator)
- Compatible with memory-based features (line-locked clock)
- Boundary scan test circuit complies with the *IEEE Std. 1149.1 – 1990* (ID-Code = 0 7111 02 B)
- I<sup>2</sup>C-bus controlled (full read-back ability by an external controller).

## 2 APPLICATIONS

- Desktop video
- Multimedia
- Digital television
- Image processing
- Video phone.

## 3 GENERAL DESCRIPTION

The Video Input Processor (VIP) is a combination of a two-channel analog preprocessing circuit including source selection, anti-aliasing filter and ADC, an automatic clamp and gain control, a Clock Generation Circuit (CGC), a digital multi-standard decoder (PAL BGHI, PAL M, PAL N, NTSC M and NTSC N), a brightness/contrast/saturation control circuit and a colour space matrix (see Fig.1).

The CMOS circuit SAA7111, analog front-end and digital video decoder, is a highly integrated circuit for desktop video applications. The decoder is based on the principle of line-locked clock decoding and is able to decode the colour of PAL and NTSC signals into CCIR-601 compatible colour component values. The SAA7111 accepts as analog inputs CVBS or S-video (Y/C) from TV or VTR sources. The circuit is I<sup>2</sup>C-bus controlled.

## Video Input Processor (VIP)

SAA7111

## 4 QUICK REFERENCE DATA

SYMBOL	PARAMETER	MIN.	TYP.	MAX.	UNIT
V <sub>DDD</sub>	digital supply voltage	4.5	5.0	5.5	V
V <sub>DDA</sub>	analog supply voltage	4.75	5.0	5.25	V
T <sub>amb</sub>	operating ambient temperature	0	25	70	°C
P <sub>A+D</sub>	analog and digital power	0.77	1.0	1.26	W

## 5 ORDERING INFORMATION

TYPE NUMBER	PACKAGE		
	NAME	DESCRIPTION	VERSION
SAA7111WP	PLCC68	plastic leaded chip carrier; 68 leads	SOT188-2
SAA7111H	QFP64	plastic quad flat package; 64 leads (lead length 1.6 mm); body 14 × 14 × 2.7 mm	SOT393-1

# Video Input Processor (VIP)

# SAA7111

## 6 BLOCK DIAGRAM

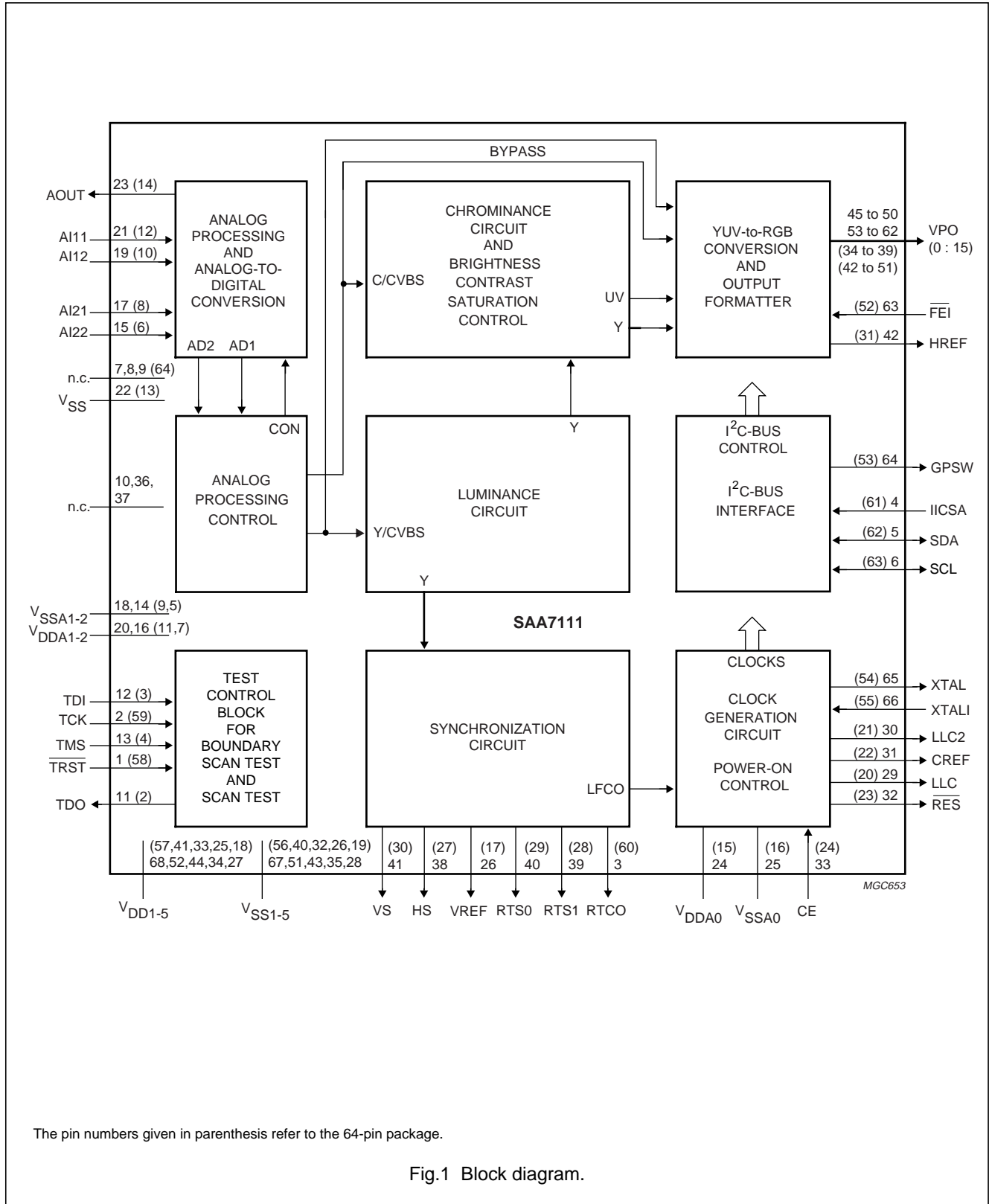

The pin numbers given in parenthesis refer to the 64-pin package.

Fig.1 Block diagram.

## Video Input Processor (VIP)

SAA7111

## 7 PINNING

SYMBOL	PINS		I/O	DESCRIPTION
	PLCC68	QFP64		
TRST	1	58	I	Test reset input not (active LOW), for boundary scan test; notes 1, 2, 3 and 4.
TCK	2	59	I	Test clock input for boundary scan test; note 3.
RTCO	3	60	O	Real time control output: contains information about actual system clock frequency, subcarrier frequency and phase and PAL sequence.
IICSA	4	61	I	I <sup>2</sup> C-bus slave address select input; 0 → 48H for write, 49H for read, 1 → 4AH for write, 4BH for read.
SDA	5	62	I/O	I <sup>2</sup> C-bus serial data input/output.
SCL	6	63	I/O	I <sup>2</sup> C-bus serial clock input/output.
n.c.	7	64	–	Not connected.
n.c.	8	–	–	Not connected.
n.c.	9	–	–	Not connected.
n.c.	10	1	–	Not connected.
TDO	11	2	O	Test data output for boundary scan test; note 3.
TDI	12	3	I	Test data input for boundary scan test; note 3.
TMS	13	4	I	Test mode select input for boundary scan test or scan test; note 3.
V <sub>SSA2</sub>	14	5	GND	Ground for analog supply voltage channel 2.
AI22	15	6	I	Analog input 22.
V <sub>DDA2</sub>	16	7	P	Positive supply voltage (+5 V) for analog channel 2.
AI21	17	8	I	Analog input 21.
V <sub>SSA1</sub>	18	9	GND	Ground for analog supply voltage channel 1.
AI12	19	10	I	Analog input 12.
V <sub>DDA1</sub>	20	11	P	Positive supply voltage (+5 V) for analog channel 1.
AI11	21	12	I	Analog input 11.
V <sub>SSS</sub>	22	13	GND	Substrate (connected to analog ground).
AOUT	23	14	O	Analog test output; for testing the analog input channels.
V <sub>DDA0</sub>	24	15	P	Positive supply voltage (+5 V) for internal CGC.
V <sub>SSA0</sub>	25	16	GND	Ground for internal CGC.
VREF	26	17	O	Vertical reference output signal (I <sup>2</sup> C-bit COMPO = 0) or inverse composite blank signal (I <sup>2</sup> C-bit COMPO = 1) (enabled via I <sup>2</sup> C-bit OEHV).
V <sub>DD5</sub>	27	18	P	Positive digital supply voltage 5 (+5 V).
V <sub>SS5</sub>	28	19	GND	Digital ground for positive supply voltage 5.
LLC	29	20	O	Line-locked system clock output (27 MHz).
LLC2	30	21	O	Line-locked clock 1/2 output (13.5 MHz).
CREF	31	22	O	Clock reference output: this is a clock qualifier signal distributed by the CGC for a data rate of LLC2. Using CREF all interfaces on the VPO-bus are able to generate a bus timing with identical phase. If CCIR-656 format is selected (OFTS0 = 1 and OFTS1 = 1) an inverse composite blank signal (pixel qualifier) is provided on this pin.

## Video Input Processor (VIP)

## SAA7111

SYMBOL	PINS		I/O	DESCRIPTION
	PLCC68	QFP64		
$\overline{\text{RES}}$	32	23	O	Reset output (active LOW); sets the device into a defined state. All data outputs are in high impedance state. The I <sup>2</sup> C-bus is reset (waiting for start condition) note 4.
CE	33	24	I	Chip enable; connection to ground forces a reset.
V <sub>DD4</sub>	34	25	P	Positive digital supply voltage 4 (+5 V).
V <sub>SS4</sub>	35	26	GND	Digital ground for positive supply voltage 4.
n.c.	36	–	–	Not connected.
n.c.	37	–	–	Not connected.
HS	38	27	O	Horizontal sync output signal (programmable); the positions of the positive and negative slopes are programmable in 8 LLC increments over a complete line (equals 64 $\mu$ s) via I <sup>2</sup> C-bus bytes HSB and HSS. Fine position adjustment in 2 LLC increments can be performed via I <sup>2</sup> C-bits HDEL1 and HDEL0.
RTS1	39	28	O	Two functions output; controlled by I <sup>2</sup> C-bit RTSE1. RTSE1 = 0: PAL line identifier (LOW = PAL line); indicates the inverted and non-inverted R – Y component for PAL signals. RTSE1 = 1: H-PLL locked indicator; a high state indicates that the internal horizontal PLL has locked.
RTS0	40	29	O	Two functions output; controlled by I <sup>2</sup> C-bit RTSE0. RTSE0 = 0: odd/even field identification (HIGH = odd field). RTSE0 = 1: vertical locked indicator; a HIGH state indicates that the internal VNL has locked.
VS	41	30	O	Vertical sync output signal (enabled via I <sup>2</sup> C-bit OEHV); this signal indicates the vertical sync with respect to the YUV output. The HIGH period of this signal is approximately six lines if the vertical noise limiter (VNL) function is active. The positive slope contains the phase information for a deflection controller.
HREF	42	31	O	Horizontal reference output signal (enabled via I <sup>2</sup> C-bit OEHV); this signal is used to indicate data on the digital YUV bus. The positive slope marks the beginning of a new active line. The HIGH period of HREF is 720 Y samples long. HREF can be used to synchronize data multiplexer/demultiplexers. HREF is also present during the vertical blanking interval.
V <sub>SS3</sub>	43	32	GND	Digital ground for positive supply voltage 3.
V <sub>DD3</sub>	44	33	P	Positive digital supply voltage 3 (+5 V).
VPO (15 to 10)	45 to 50	34 to 39	O	Digital VPO-bus (Video Port Out) output signal; higher bits of the 16-bit YUV-bus or the 16-bit RGB-bus output signal. The output data rate, the format and multiplexing scheme of the VPO-bus are controlled via I <sup>2</sup> C-bits OFTS0 and OFTS1. With I <sup>2</sup> C-bit VIPB = 1 the six MSBs of the digitized input signal (AD1 [7 to 2]) are connected to these outputs.
V <sub>SS2</sub>	51	40	GND	Digital ground for positive supply voltage 2.
V <sub>DD2</sub>	52	41	P	Positive digital supply voltage 2 (+5 V).

## Video Input Processor (VIP)

SAA7111

SYMBOL	PINS		I/O	DESCRIPTION
	PLCC68	QFP64		
VPO (9 to 0)	53 to 62	42 to 51	O	Digital VPO-bus output signal; lower bits of the 16-bit YUV-bus or the 16-bit RGB-bus output signal. The output data rate, the format and multiplexing schema of the VPO-bus are controlled via I <sup>2</sup> C-bits OFTS0 and OFTS1. With I <sup>2</sup> C-bit VIPB = 1 the digitized input signals (AD1 [1 and 0] and AD2 [7 to 0]) are connected to these outputs.
$\overline{\text{FEI}}$	63	52	I	Fast enable input signal (active LOW); this signal is used to control fast switching on the digital YUV-bus. A HIGH at this input forces the IC to set its Y and UV outputs to the high impedance state; note 4.
GPSW	64	53	O	General purpose switch output; the state of this signal is set via I <sup>2</sup> C-bus control and the levels are TTL compatible.
XTAL	65	54	O	Second output terminal of crystal oscillator; not connected if external clock signal is used.
XTALI	66	55	I	Input terminal for 24.576 MHz crystal oscillator or connection of external oscillator with CMOS compatible square wave clock signal.
V <sub>SS1</sub>	67	56	GND	Digital ground for positive supply voltage 1.
V <sub>DD1</sub>	68	57	P	Positive digital supply voltage 1 (+5 V).

**Notes**

1. For board design without boundary scan implementation (pin compatibility with the SAA7110) connect the  $\overline{\text{TRST}}$  pin to ground.
2. This pin provides easy initialization of BST circuit.  $\overline{\text{TRST}}$  can be used to force the TAP (Test Access Port) controller to the Test-Logic-Reset state (normal operation) at once.
3. In accordance with the *IEEE1149.1* standard the pads TCK, TDI, TMS and  $\overline{\text{TRST}}$  are input pads with an internal pull-up transistor and TDO a 3-state output pad.
4. All pin names that carry an 'overscore' have been renamed due to Philips pin name conventions. In previous data sheet versions these pins were marked by the suffix 'N', e.g.  $\overline{\text{TRST}}$  = TRSTN.



Video Input Processor (VIP)

SAA7111

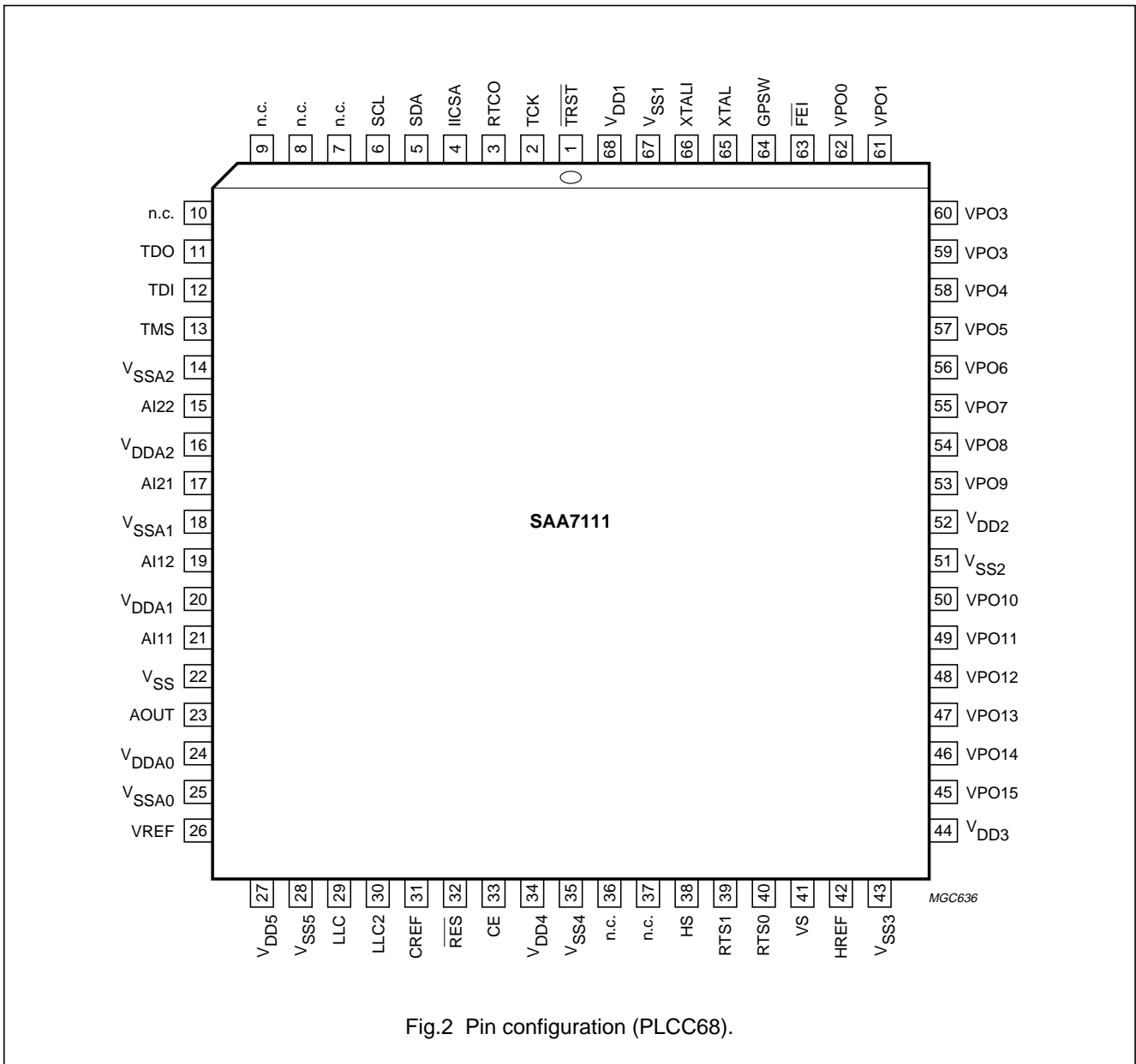

Fig.2 Pin configuration (PLCC68).

Video Input Processor (VIP)

SAA7111

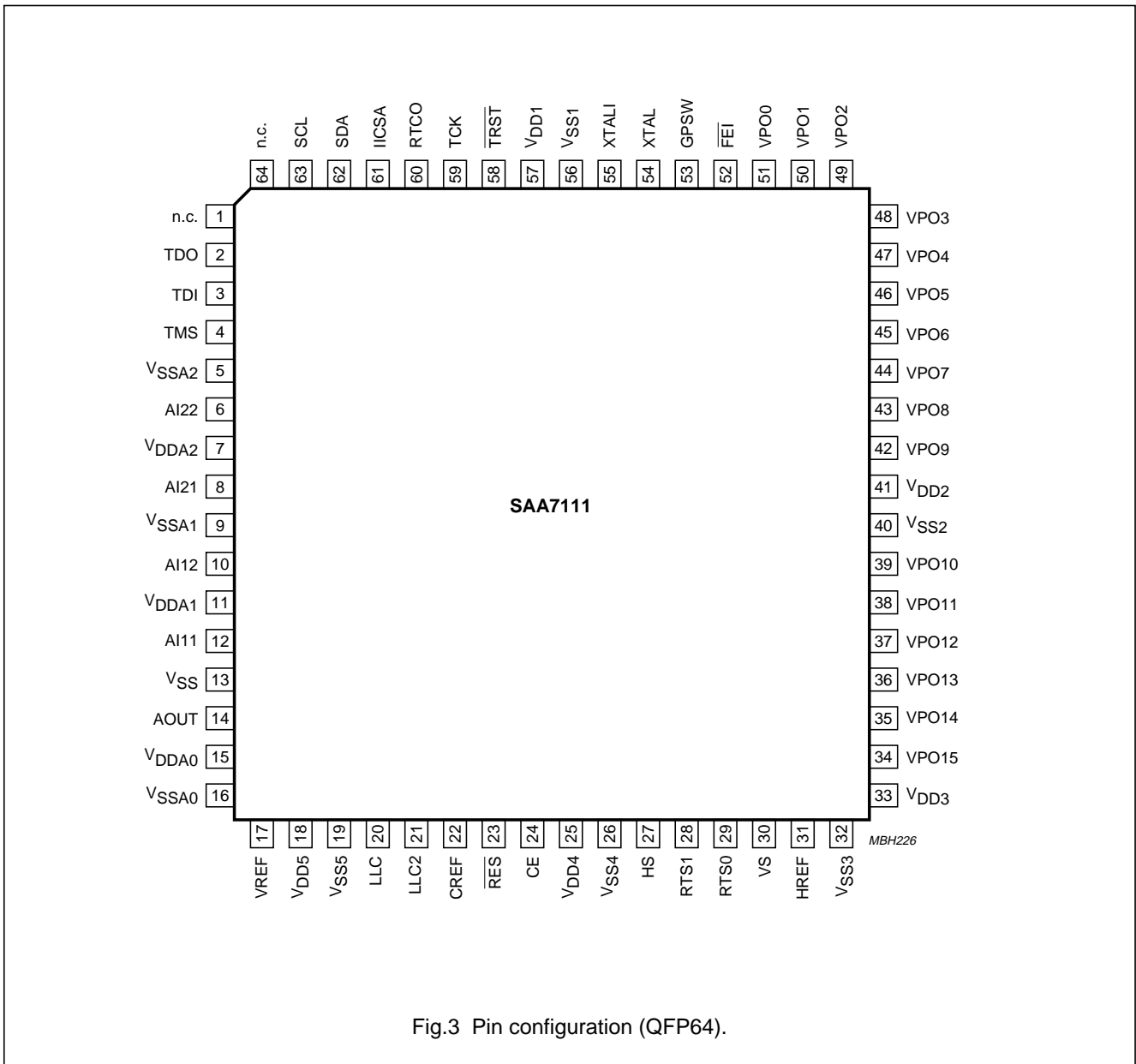

Fig.3 Pin configuration (QFP64).

# Video Input Processor (VIP)

# SAA7111

## 8 FUNCTIONAL DESCRIPTION

### 8.1 Analog input processing

The SAA7111 offers four analog signal inputs, two analog main channels with clamp circuit, analog amplifier, anti-alias filter and video CMOS ADC (see Fig.6).

### 8.2 Analog control circuits

The anti-alias filters are adapted to the line-locked clock frequency with help from a filter control. During the vertical blanking, time gain and clamping control are frozen.

#### 8.2.1 CLAMPING

The clamp control circuit controls the correct clamping of the analog input signals. The coupling capacitor is also used to store and filter the clamping voltage. An internal digital clamp comparator generates the information with respect to clamp-up or clamp-down. The clamping levels for the two ADC channels are fixed for luminance (60) and chrominance (128). Clamping time in normal use is set with the HCL pulse at the back porch of the video signal.

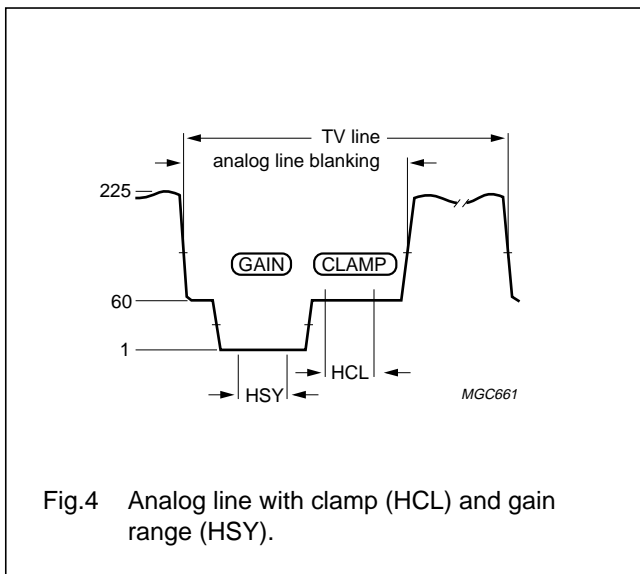

Fig.4 Analog line with clamp (HCL) and gain range (HSY).

#### 8.2.2 GAIN CONTROL

Signal (white) peak control limits the gain at signal overshoots. The flow charts (see Figs 10 and 11) show more details of the AGC. The influence of supply voltage variation within the specified range is automatically eliminated by clamp and automatic gain control.

The gain control circuit receives (via the I<sup>2</sup>C-bus) the static gain levels for the two analog amplifiers or controls one of these amplifiers automatically via a built-in automatic gain

control (AGC) as part of the Analog Input Control (AICO). The AGC (automatic gain control for luminance) is used to amplify a CVBS or Y signal to the required signal amplitude, matched to the ADCs input voltage range. The AGC active time is the sync bottom of the video signal.

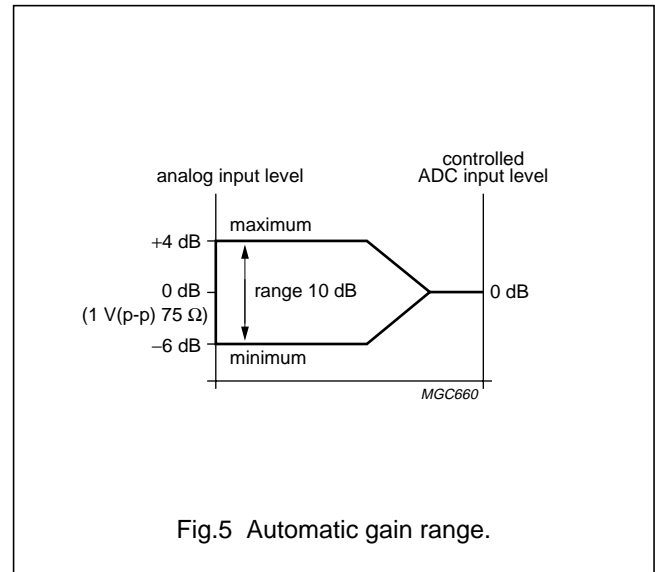

Fig.5 Automatic gain range.

### 8.3 Chrominance processing

The 8-bit chrominance signal is fed to the multiplication inputs of a quadrature demodulator, where two subcarrier signals from the local oscillator DTO1 are applied (0 and 90° phase relationship to the demodulator axis). The frequency is dependent on the present colour standard. The output signals of the multipliers are low-pass filtered (four programmable characteristics) to achieve the desired bandwidth for the colour difference signals.

The colour difference signals are fed to the Brightness/Contrast/Saturation block (BCS), which includes the following five functions;

1. AGC (automatic gain control for chrominance)
2. Chroma amplitude matching [different gain factors for (R-Y) and (B-Y) to achieve CCIR-601 levels Cr and Cb]
3. Chroma saturation control
4. Luminance contrast and brightness
5. Limiting YUV to the values 1 (min.) and 254 (max.) to fulfil CCIR-601 requirements.

## Video Input Processor (VIP)

SAA7111

The burst processing block provides the feedback loop of the chroma PLL and contains;

- Burst gate accumulator
- Colour identification and killer
- Comparison nominal/actual burst amplitude
- Loop filter chroma gain control
- Loop filter chroma PLL
- PAL sequence generation
- Increment generation for DTO1 with divider to generate stable subcarrier for non-standard signals.

The chroma comb filter block eliminates crosstalk between the chrominance channels in accordance with the PAL standard requirements. For NTSC colour standards the chroma comb filter can be used to eliminate crosstalk from luminance to chrominance (cross-colour) for vertical structures. The comb filter can be switched off if desired.

The resulting signals are fed to the variable Y-delay compensation, RGB matrix, dithering circuit and output interface, which contains the VPO output formatter and the output control logic (see Fig.7).

### 8.4 Luminance processing

The 8-bit luminance signal, a digital CVBS format or a luminance format (S-VHS, HI8), is fed through a switchable prefilter. High frequency components are emphasized to compensate for loss. The following chrominance trap filter ( $f_0 = 4.43$  or  $3.58$  MHz centre frequency selectable) eliminates most of the colour carrier signal, therefore, it must be bypassed for S-video (S-VHS, HI8) signals.

The high frequency components of the luminance signal can be peaked (control for sharpness improvement via I<sup>2</sup>C-bus) in two band-pass filters with selectable transfer characteristic. This signal is then added to the original (unpeaked) signal. A switchable amplifier achieves common DC amplification, because the DC gains are different in both chrominance trap modes. The improved luminance signal is fed to the BCS control located in the chrominance processing block (see Fig.8).

### 8.5 RGB matrix

Y, Cr and Cb-data are converted after interpolation into RGB data in accordance with CCIR-601 recommendation. The realized matrix equations consider the digital quantization:

$$R = Y + 1.371 Cr$$

$$G = Y - 0.336 Cb - 0.698 Cr$$

$$B = Y + 1.732 Cb.$$

After dithering (noise shaping) the RGB data is fed to the output interface within the VPO-bus output formatter.

### 8.6 VPO-bus (digital outputs)

The 16-bit VPO-bus transfers digital data from the output interfaces to a feature box or a field memory, a digital colour space converter (SAA7192 DCSC), a video enhancement and digital-to-analog processor (SAA7165 VEDA2) or a colour graphics board (Targa-format) as a graphical user interface.

The output data formats are controlled via the I<sup>2</sup>C-bus bits OFTS0, OFTS1 and RGB888. Timing for the data stream formats, 411 YUV (12-bit), 422 YUV (16-bit), 565 RGB (16-bit) and 888 RGB (24-bit) with an LLC2 data rate, is achieved by marking each second positive rising edge of the clock LLC in conjunction with CREF (clock reference) (except RGB 888, see special application in Fig.27). The higher output signals VPO15 to VPO8 in the YUV format perform the digital luminance signal.

The lower output signals VPO7 to VPO0 in the YUV format are the bits of the multiplexed colour difference signals (B-Y) and (R-Y). The arrangement of the RGB 565 and RGB 888 data stream bits on the VPO-bus is given in Table 5.

The data stream format 422 YUV (the 8 higher output signals VPO15 to VPO8) in LLC data rate fulfils the CCIR-656 standard with its own timing reference code at the start and end of each video data block.

A pixel in the format tables is the time required to transfer a full set of samples. In the event of a 4 : 2 : 2 format two luminance samples are transmitted in comparison to one (B-Y) and one (R-Y) sample within a pixel. The time frames are controlled by the HREF signal.

## Video Input Processor (VIP)

## SAA7111

Fast enable is achieved by setting input  $\overline{\text{FEI}}$  to LOW. The signal is used to control fast switching on the digital VPO-bus. HIGH on this pin forces the YUV outputs to a high-impedance state (see Figs 15 and 17).

The digitized analog PAL or NTSC signals AD1 (7 to 0) and AD2 (7 to 0) are connected directly to the VPO-bus via I<sup>2</sup>C-bit VIPB = 1.

AD1 (7 to 0) → VPO (15 to 8) and  
AD2 (7 to 0) → VPO (7 to 0)

The selection of the analog input channels are controlled via I<sup>2</sup>C-bus subaddress 02 MODE select.

### 8.7 Synchronization

The prefiltered luminance signal is fed to the synchronization stage. Its bandwidth is reduced to 1 MHz in a low-pass filter. The sync pulses are sliced and fed to the phase detectors where they are compared with the sub-divided clock frequency. The resulting output signal is applied to the loop filter to accumulate all phase deviations. Internal signals (e.g. HCL and HSY) are generated in accordance with analog front-end requirements. The output signals HS, VS, and PLIN are locked to the timing reference, guaranteed between the input signal and the HREF signal, as further improvements to the circuit may change the total processing delay. It is therefore not recommended to use them for applications which require absolute timing accuracy on the input signals. The loop filter signal drives an oscillator to generate the line frequency control signal LFCO (see Fig.8).

### 8.8 Clock generation circuit

The internal CGC generates all clock signals required for the video input processor. The internal signal LFCO is a digital-to-analog converted signal provided by the horizontal PLL. It is the multiple of the line frequency ( $6.75 \text{ MHz} = 432 \times f_h$ ). Internally the LFCO signal is multiplied by a factor of 2 or 4 in the PLL circuit (including phase detector, loop filtering, VCO and frequency divider) to obtain the LLC and LLC2 output clock signals. The rectangular output clocks have a 50% duty factor (see Fig.22).

### 8.9 Power-on reset and CE input

A missing clock, insufficient digital or analog  $V_{\text{DDA0}}$  supply voltages (below 3.5 V) will initiate the reset sequence; all outputs are forced to 3-state. The indicator output  $\overline{\text{RES}}$  is LOW for approximately 128 LLC after the internal reset and can be applied to reset other circuits of the digital TV system.

It is possible to force a reset by pulling the CE (chip enable) to ground. After the rising edge of CE and sufficient power supply voltage, the outputs LLC, LLC2, CREF, RTCO, RTS0, RTS1, GPSW and SDA return from 3-state to active, while HREF, VREF, HS and VS remain in 3-state and have to be activated via I<sup>2</sup>C-bus programming (see Table 4).

### 8.10 RTCO output

The real time control and status output signal contains serial information about the actual system clock (increment of the HPLL), subcarrier frequency [increment and phase (via reset) of the FSC-PLL] and PAL sequence bit. The signal can be used for various applications in external circuits, e.g. in a digital encoder to achieve clean encoding (see Fig.16).

### 8.11 The Line-21 text slicer

The text slicer block detects and acquires Line-21 closed captioning data from a 525-line CVBS signal. Extended data services on Line-21 Field 2 are also supported. If valid data is detected the two data bytes are stored in two I<sup>2</sup>C-bus registers. A parity check is also performed and the result is stored in the MSB of the corresponding byte. A third I<sup>2</sup>C-bus register is provided for data valid and data ready flags. The two bits F1VAL and F2VAL indicate that the input signal carries valid Closed Captioning data on the corresponding fields. The data ready bits F1RDY and F2RDY have to be evaluated if asynchronous I<sup>2</sup>C-bus reading is used.

#### 8.11.1 SUGGESTIONS FOR I<sup>2</sup>C-BUS INTERFACE OF THE DISPLAY SOFTWARE READING LINE-21 DATA

There are two methods by which the software can acquire the data;

1. Synchronous reading once per frame (or once per field): It can use either the rising edge (Line-21 Field 1) or both edges (Line-21 Field 1 or 2) of the ODD signal (pin RTS0) to initiate an I<sup>2</sup>C-bus read transfer of the three registers 1A, 1B and 1C
2. Asynchronous reading: It can poll either the F1RDY bit (Line-21 Field 1) or both F1RDY/F2RDY bits (Line-21 Field 1 or 2). After valid data has been read the corresponding F\*RDY bit is set to LOW until new data has arrived. The polling frequency has to be slightly higher than the frame or field frequency, respectively.

Video Input Processor (VIP)

SAA7111

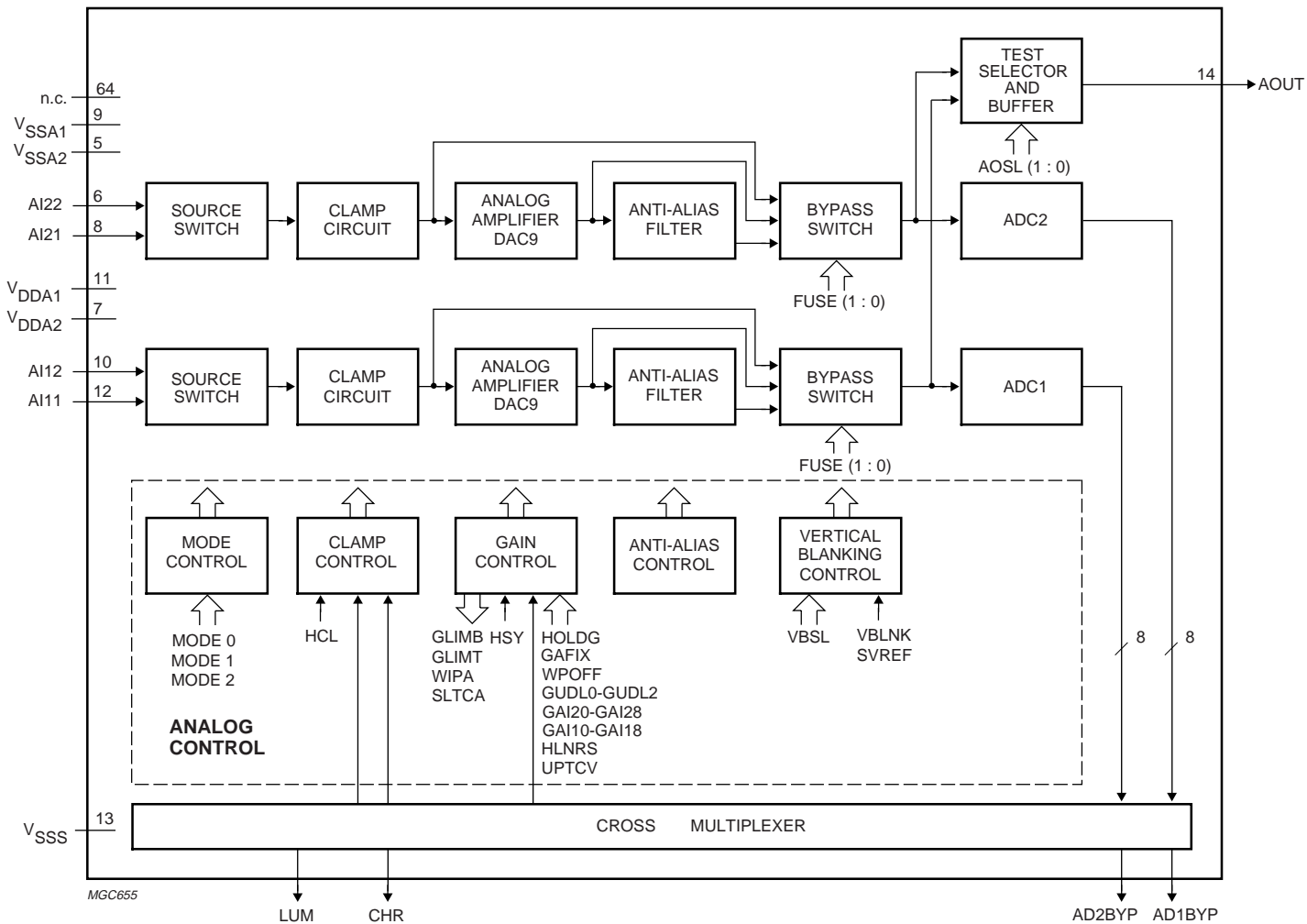

The pin numbers given in parenthesis refer to the 64-pin package.

Fig.6 Analog input processing.

Video Input Processor (VIP)

SAA7111

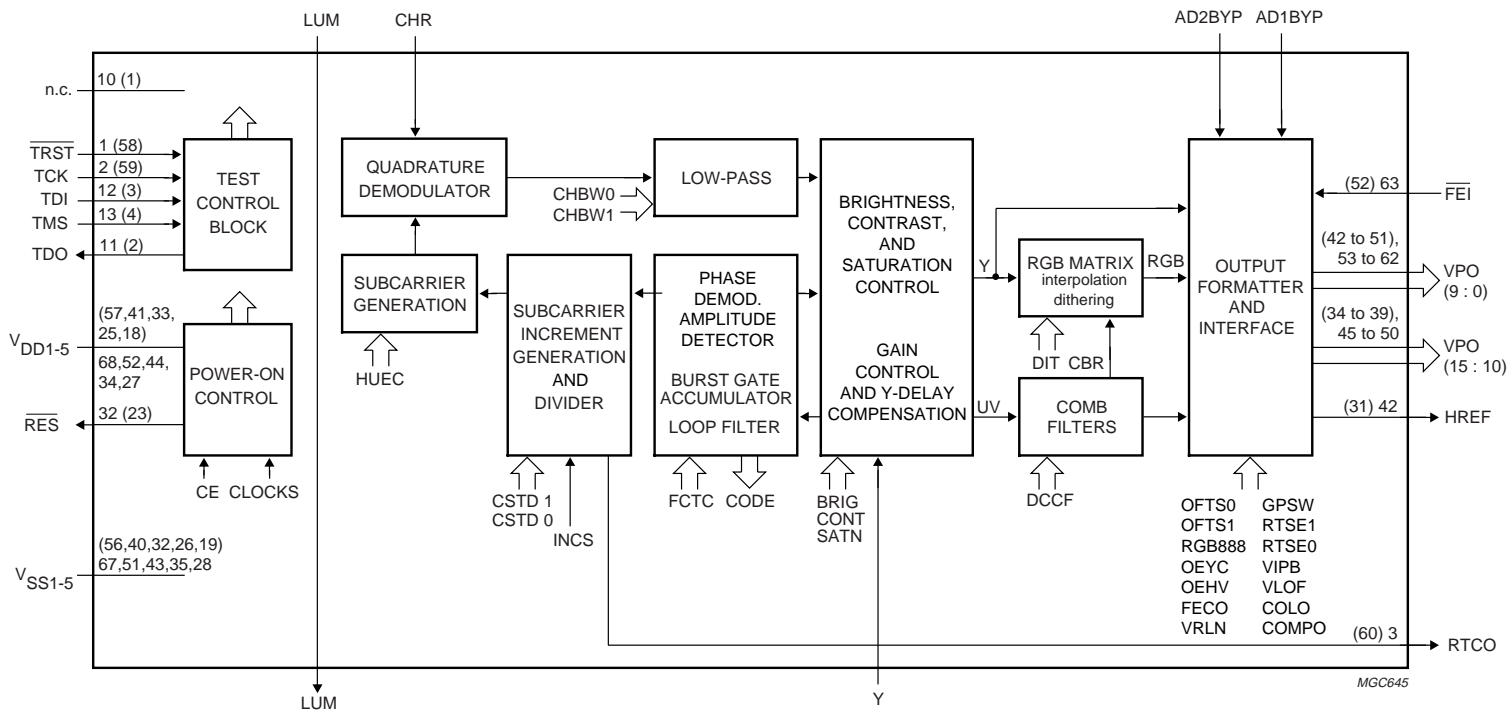

The pin numbers given in parenthesis refer to the 64-pin package.

Fig.7 Chrominance circuit.

Video Input Processor (VIP)

SAA7111

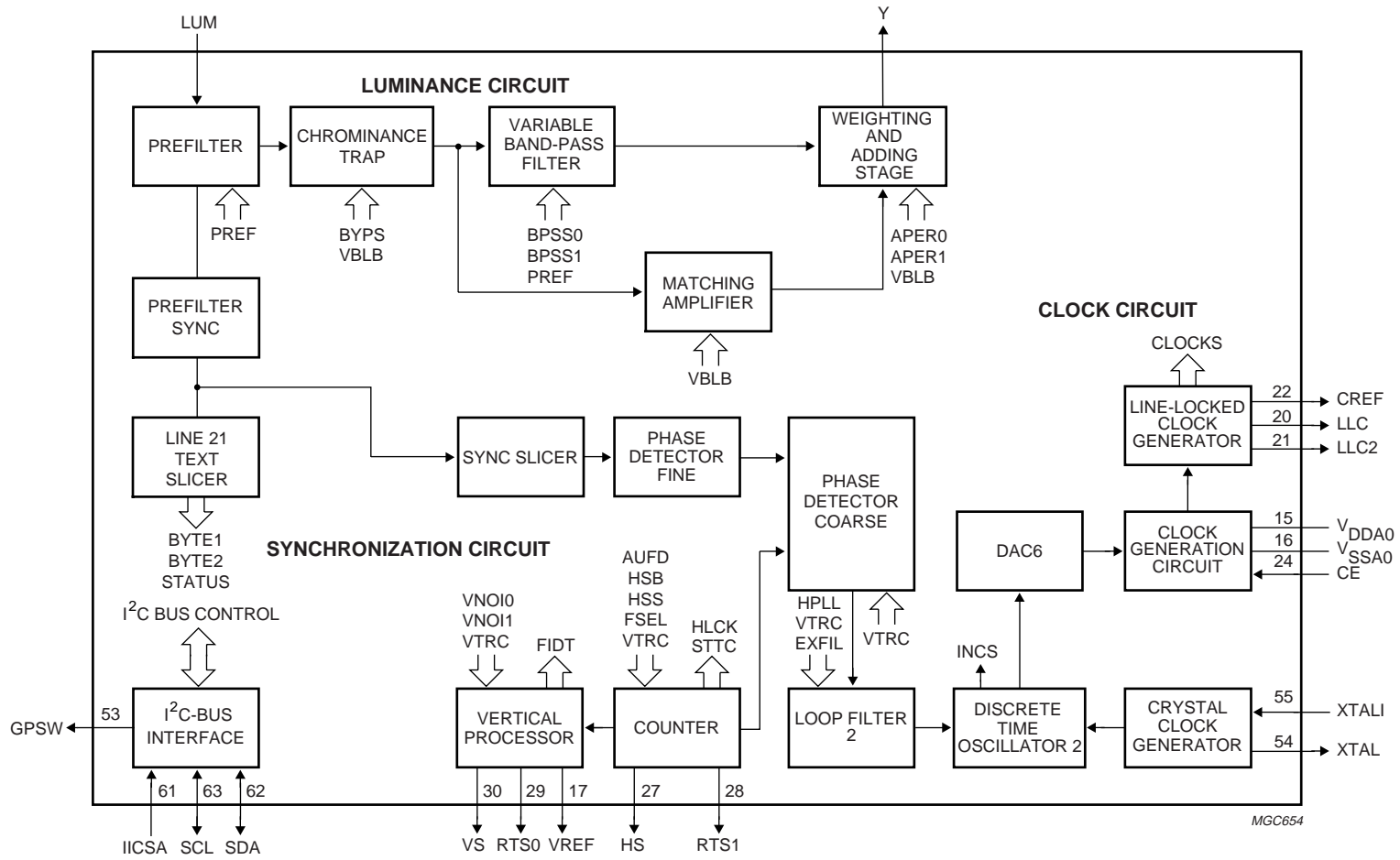

The pin numbers given in parenthesis refer to the 64-pin package.

Fig.8 Luminance and sync processing.



Video Input Processor (VIP)

SAA7111

9 GAIN CHARTS

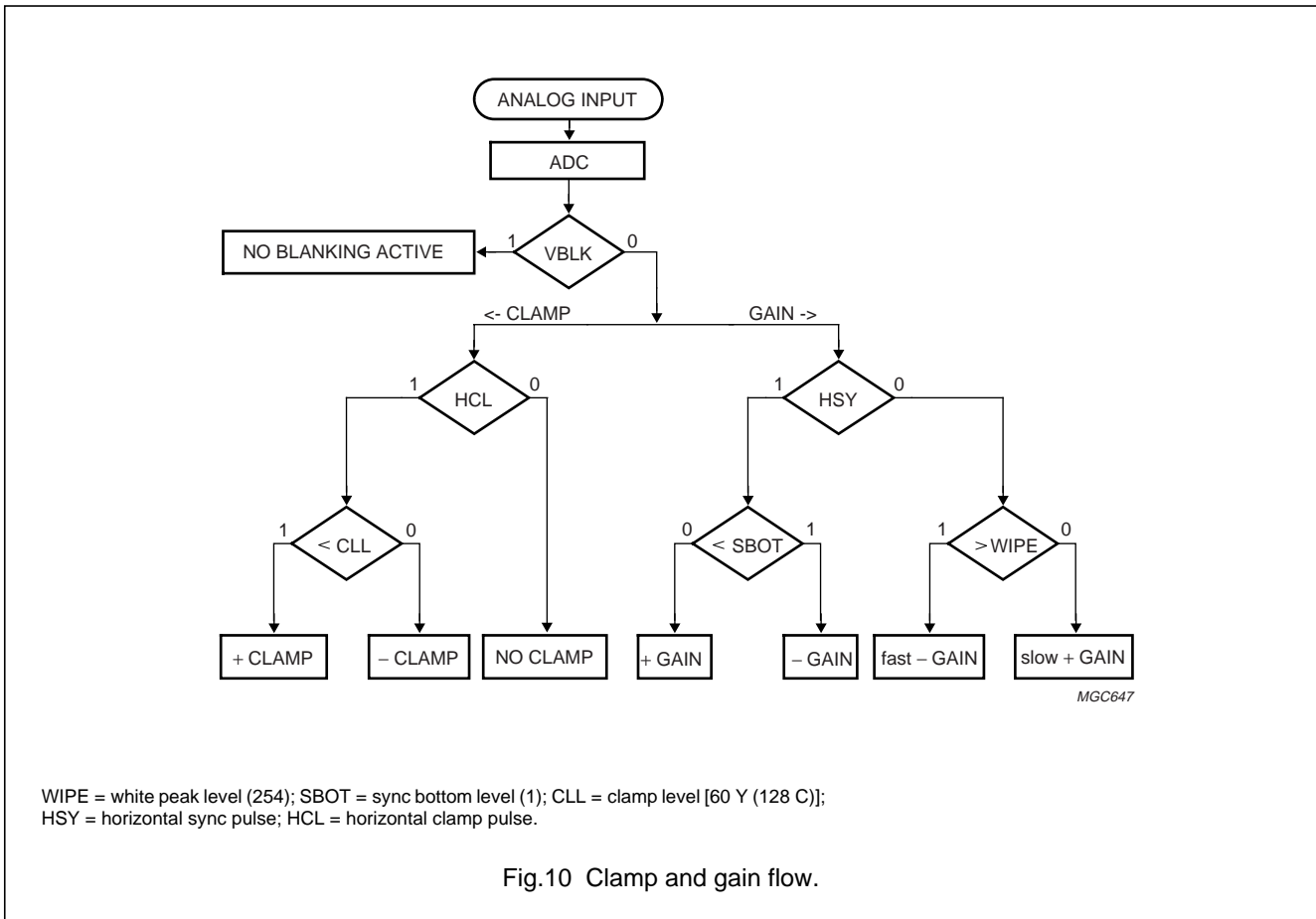
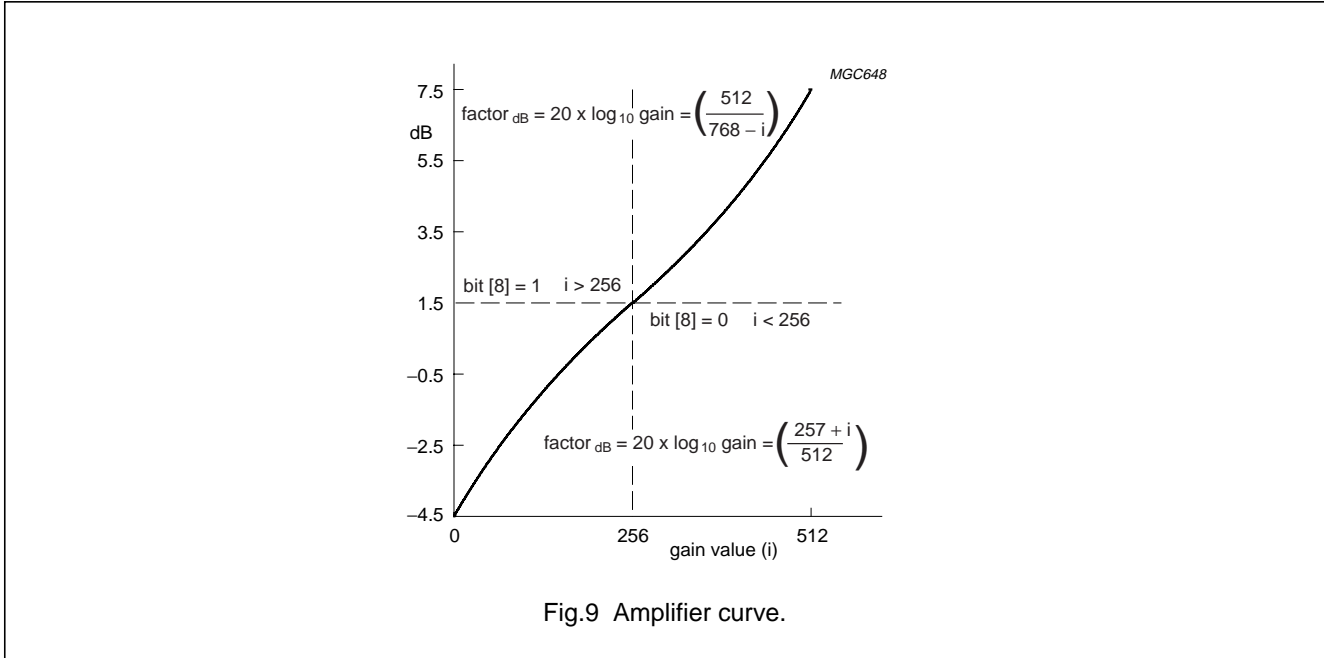

Video Input Processor (VIP)

SAA7111

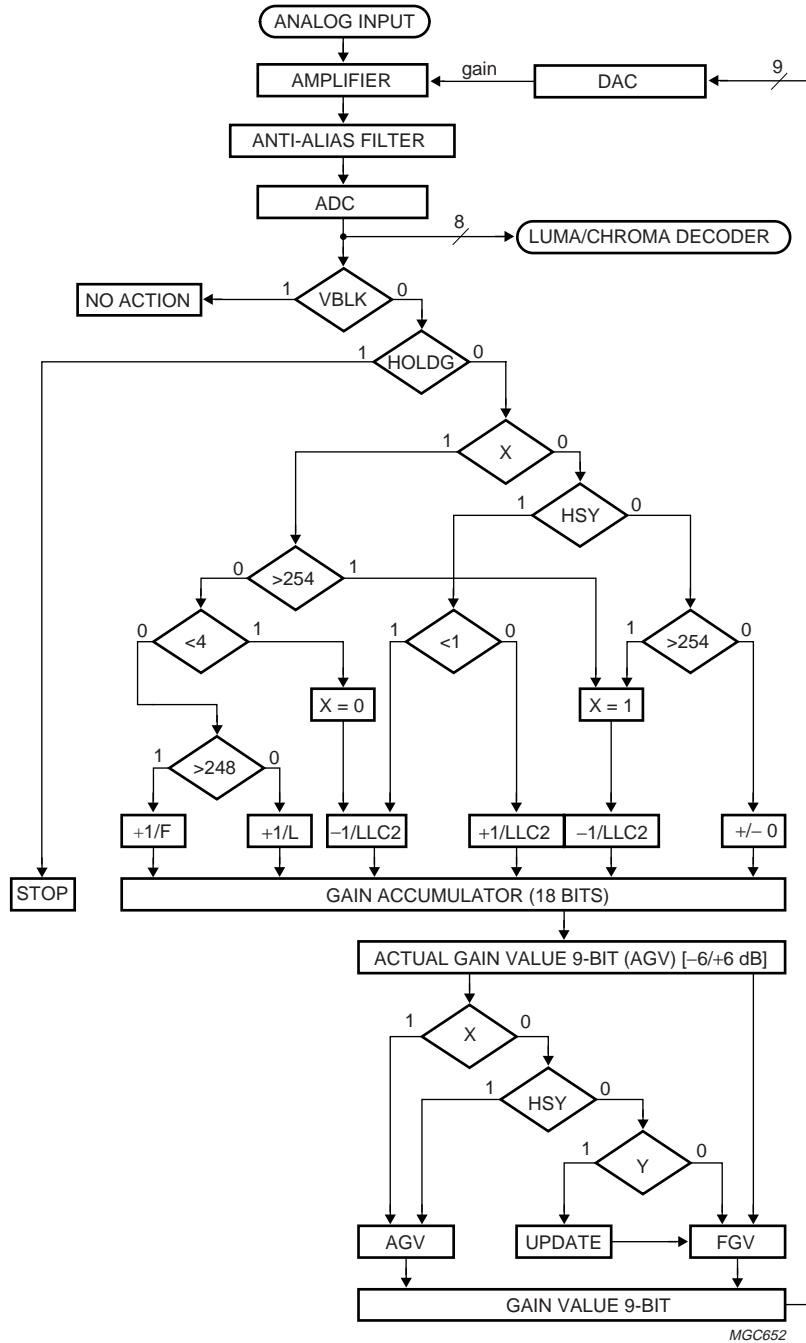

X = system variable; Y = AGV - FGV > GUDL; VBLK = vertical blanking pulse; HSY = horizontal sync pulse; AGV = actual gain value; FGV = frozen gain value.

Fig.11 Gain flow chart.

## Video Input Processor (VIP)

SAA7111

**10 LIMITING VALUES**

In accordance with the Absolute Maximum Rating System (IEC 134).

SYMBOL	PARAMETER	CONDITIONS	MIN.	MAX.	UNIT
V <sub>DDD</sub>	digital supply voltage		-0.5	+6.5	V
V <sub>DDA</sub>	analog supply voltage		-0.5	+6.5	V
V <sub>diff</sub>	voltage difference between V <sub>SSAall</sub> and V <sub>SSall</sub>		-	100	mV
T <sub>stg</sub>	storage temperature		-65	+150	°C
T <sub>amb</sub>	operating ambient temperature		0	70	°C
T <sub>amb(bias)</sub>	operating ambient temperature under bias		-10	+80	°C
V <sub>ESD</sub>	electrostatic discharge all pins	note 1	-2000	+2000	V

**Note**

- Human body model: equivalent to discharging a 100 pF capacitor through a 1.5 kΩ resistor.

**11 CHARACTERISTICS**V<sub>DDD</sub> = 4.5 to 5.5 V; V<sub>DDA</sub> = 4.75 to 5.25 V; T<sub>amb</sub> = 25 °C; unless otherwise specified.

SYMBOL	PARAMETER	CONDITIONS	MIN.	TYP.	MAX.	UNIT
<b>Supplies</b>						
V <sub>DDD</sub>	digital supply voltage		4.5	5.0	5.5	V
I <sub>DDD</sub>	digital supply current		100	130	160	mA
P <sub>D</sub>	digital power		0.45	0.65	0.88	W
V <sub>DDA</sub>	analog supply voltage		4.75	5.0	5.25	V
I <sub>DDA</sub>	analog supply current		60	70	80	mA
P <sub>A</sub>	analog power		0.32	0.35	0.38	W
P <sub>A+D</sub>	analog and digital power		0.77	1.0	1.26	W
<b>Analog part</b>						
I <sub>clamp</sub>	clamping current	V <sub>I</sub> = 1.25 V DC	-	2	-	μA
V <sub>I(p-p)</sub>	input voltage (peak-to-peak value), AC coupling required	coupling capacitor = 10 nF; note 1	0.55	1.0	1.5	V
Z <sub>i</sub>	input impedance	clamping current off	200	-	-	kΩ
C <sub>i</sub>	input capacitance		-	-	10	pF
α <sub>CS</sub>	channel crosstalk	f <sub>i</sub> = 5 MHz	-	-50	-	dB
<b>Analog-to-digital converters</b>						
B	bandwidth	at -3 dB	-	15	-	MHz
φ <sub>diff</sub>	differential phase (amplifier plus anti-alias filter = bypass)		-	2	-	deg
G <sub>diff</sub>	differential gain (amplifier plus anti-alias filter = bypass)		-	2	-	%
f <sub>ADC</sub>	ADC clock frequency		11	-	16	MHz
DLE	DC differential linearity error		-	0.5	-	LSB
ILE	DC integral linearity error		-	1	-	LSB

## Video Input Processor (VIP)

## SAA7111

SYMBOL	PARAMETER	CONDITIONS	MIN.	TYP.	MAX.	UNIT
<b>Digital inputs</b>						
$V_{IL}$	LOW-level input voltage pins SDA and SCL		-0.5	-	+1.5	V
$V_{IH}$	HIGH-level input voltage pins SDA and SCL		$0.7V_{DDDD}$	-	$V_{DDDD} + 0.5$	V
$V_{IL(xtall)}$	LOW-level CMOS input voltage pin XTALI		-	-	$0.3V_{DDDD}$	V
$V_{IH(xtall)}$	HIGH-level CMOS input voltage pin XTALI		$0.7V_{DDDD}$	-	-	V
$V_{ILn}$	LOW-level input voltage all other inputs		-0.5	-	+0.8	V
$V_{IHn}$	HIGH-level input voltage all other inputs		2.0	-	$V_{DDDD} + 0.5$	V
$I_{LI}$	input leakage current		-	-	1	$\mu$ A
$C_{i(I/O)}$	input capacitance	inputs and outputs at high-impedance	-	-	8	pF
$C_{i(n)}$	input capacitance all other inputs		-	-	8	pF
<b>Digital outputs</b>						
$V_{OL}$	LOW-level output voltage pins SDA and SCL	SDA/SCL at 3 mA sink current	-	-	0.4	V
$V_{OL}$	LOW-level output voltage	note 2	0	-	0.6	V
$V_{OH}$	HIGH-level output voltage	note 2	2.4	-	$V_{DDDD}$	V
$V_{OL(clk)}$	LOW-level output voltage for clocks		-0.5	-	+0.6	V
$V_{OH(clk)}$	HIGH-level output voltage for clocks		2.6	-	$V_{DDDD} + 0.5$	V
<b><math>\overline{FEI}</math> input timing</b>						
$t_{SU;DAT}$	input data set-up time		13	-	-	ns
$t_{HD;DAT}$	input data hold time		3	-	-	ns
<b>Data and control output timing</b>						
$C_L$	output load capacitance		15	-	50	pF
$t_{OHD;DAT}$	output hold time	$C_L = 15$ pF	5	-	-	ns
$t_{PD}$	propagation delay	$C_L = 40$ pF	-	-	21	ns
$t_{PDZ}$	propagation delay to 3-state		-	-	21	ns

## Video Input Processor (VIP)

## SAA7111

SYMBOL	PARAMETER	CONDITIONS	MIN.	TYP.	MAX.	UNIT
<b>Clock output timing (LLC and LLC2)</b>						
$C_{L(LLC)}$	output load capacitance		15	–	40	pF
$T_{cy}$	cycle time	LLC	35	–	39	ns
		LLC2	70	–	78	ns
$\delta_{LLC}$	duty factors for $t_{LLCH}/t_{LLC}$ and $t_{LLC2H}/t_{LLC2}$	$C_L = 40$ pF	40	–	60	%
$t_r$	rise time	$V_i = 0.6$ to $2.6$ V	–	–	5	ns
$t_f$	fall time	$V_i = 2.6$ to $0.6$ V	–	–	5	ns
$t_{dLLC2}$	delay time LLC output to LLC2 output	$V_i = 1.5$ V; LLC/LLC2 = 40 pF	–1	–	+1	ns
<b>Data qualifier output timing (CREF)</b>						
$t_{OHD;CREF}$	output hold time	$C_L = 15$ pF	4	–	–	ns
$t_{PD;CREF}$	propagation delay from positive edge of LLC	$C_L = 40$ pF	–	–	20	ns
<b>Clock input timing (XTALI)</b>						
$\delta_{XTALI}$	duty factor for $t_{XTALIH}/t_{XTALI}$	nominal frequency	40	–	60	%
<b>Horizontal PLL</b>						
$f_{Hn}$	nominal line frequency	50 Hz field	–	15625	–	Hz
		60 Hz field	–	15734	–	Hz
$\Delta f_H/f_{Hn}$	permissible static deviation		–	–	5.7	%
<b>Subcarrier PLL</b>						
$f_{SCn}$	nominal subcarrier frequency	PAL BGHI and NTSC 443	–	4433619	–	Hz
		NTSC M	–	3579545	–	Hz
		PAL M	–	3575612	–	Hz
		PAL N	–	3582056	–	Hz
$\Delta f_{SCH}/f_{SCHn}$	lock-in range		$\pm 400$	–	–	Hz

Video Input Processor (VIP)

SAA7111

SYMBOL	PARAMETER	CONDITIONS	MIN.	TYP.	MAX.	UNIT
<b>Crystal oscillator</b>						
$f_n$	nominal frequency	3rd harmonic	–	24.576	–	MHz
$\Delta f/f_n$	permissible nominal frequency deviation		–	–	$\pm 50$	$10^{-6}$
$\Delta f/f_n(T)$	permissible nominal frequency deviation with temperature		–	–	$\pm 20$	$10^{-6}$
CRYSTAL SPECIFICATION (X1)						
$T_{ambX1}$	operating ambient temperature		0	–	70	$^{\circ}C$
$C_L$	load capacitance		8	–	–	pF
$R_s$	series resonance resistor		–	40	80	$\Omega$
$C_1$	motional capacitance		–	$1.5 \pm 20\%$	–	fF
$C_0$	parallel capacitance		–	$3.5 \pm 20\%$	–	pF

**Notes**

1. The levels must be measured with load circuits; 1.2 k $\Omega$  at 3 V (TTL load);  $C_L = 50$  pF.
2. The effects of rise and fall times are included in the calculation of  $t_{OHD,DAT}$ ,  $t_{PD}$  and  $t_{PDZ}$ . Timings and levels refer to drawings and conditions illustrated in Figs 12 and 13.

**Table 1** Processing delay

FUNCTION	TYPICAL ANALOG DELAY AI22 $\rightarrow$ ADCIN (AOUT) (ns)	DIGITAL DELAY ADCIN $\rightarrow$ VPO (LLC-CLOCKS) [YDEL(2 to 0) = 000]
Without amplifier or anti-alias filter	14	139
With amplifier, without anti-alias filter	30	
With amplifier plus anti-alias filter	72	

Video Input Processor (VIP)

SAA7111

12 TIMING DIAGRAMS

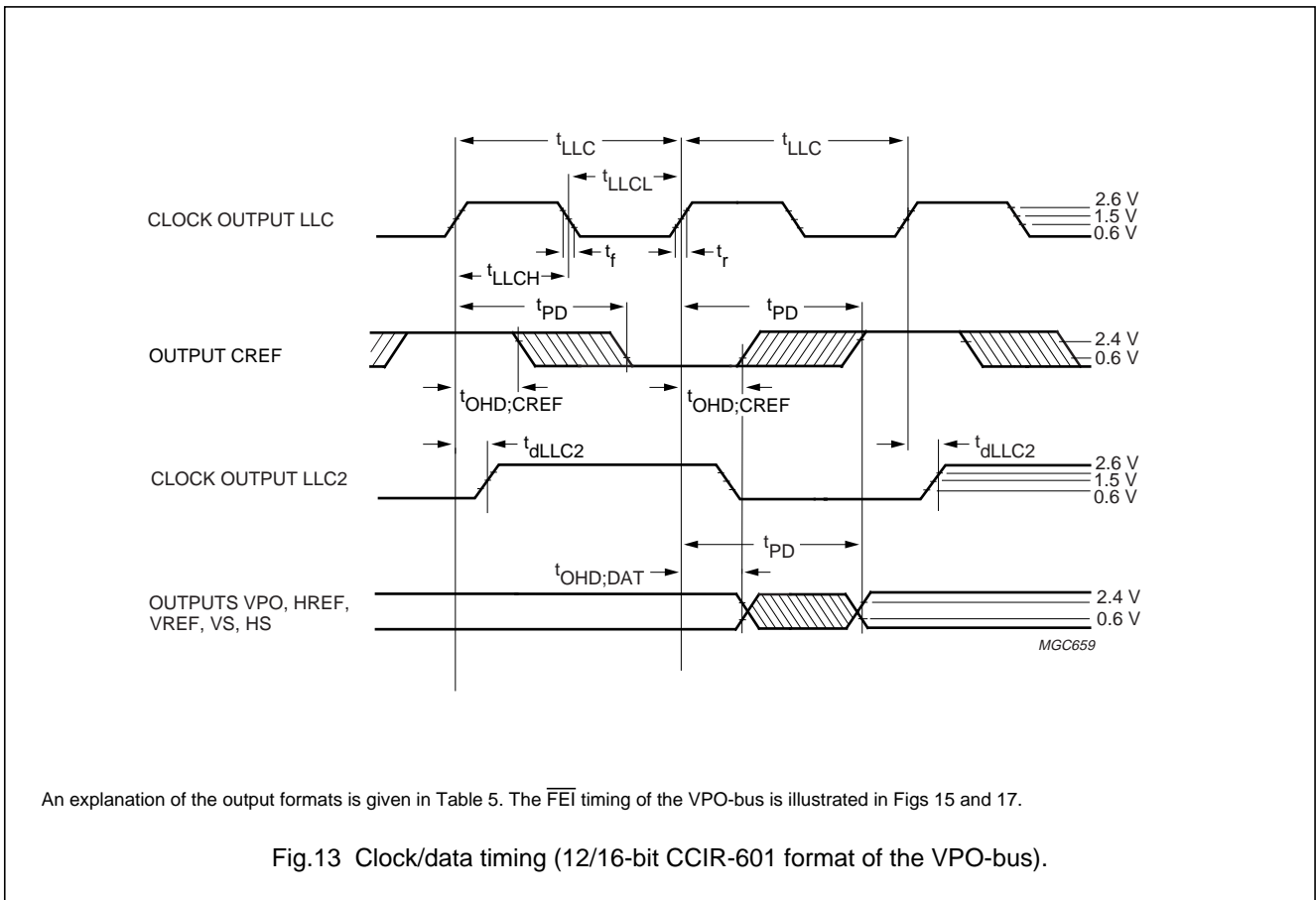
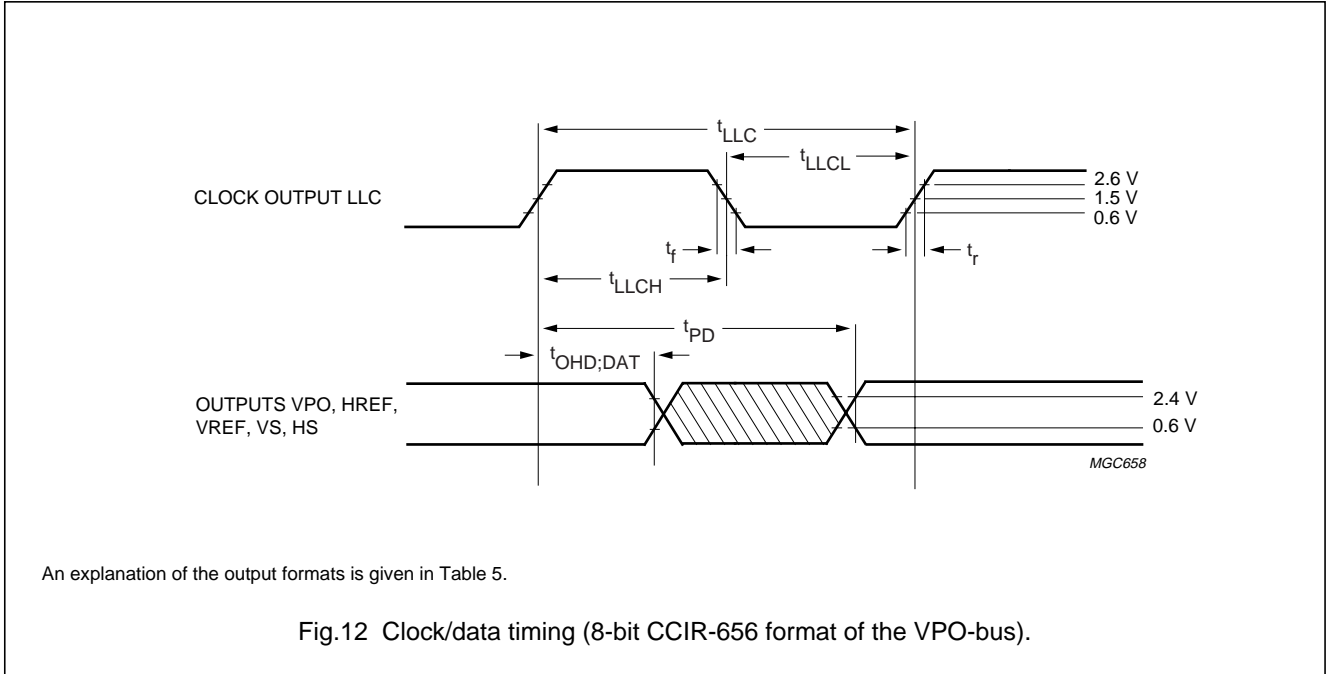

Video Input Processor (VIP)

SAA7111

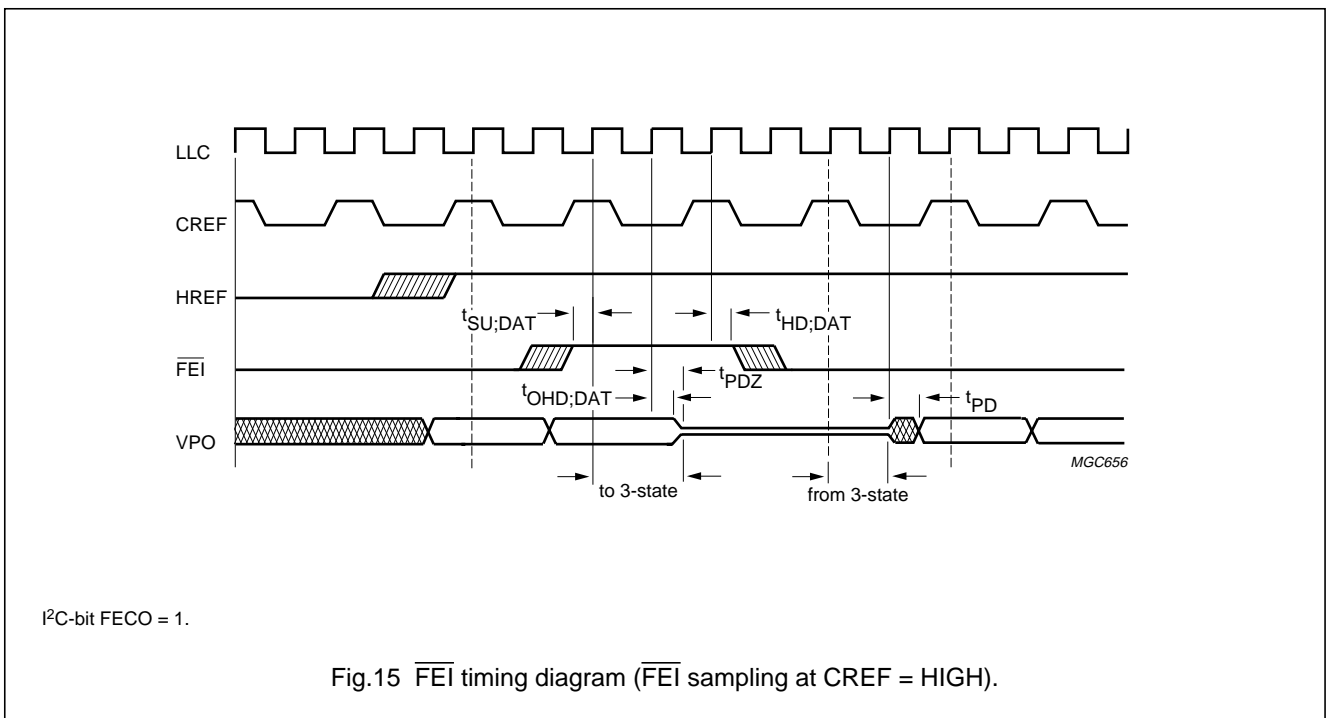
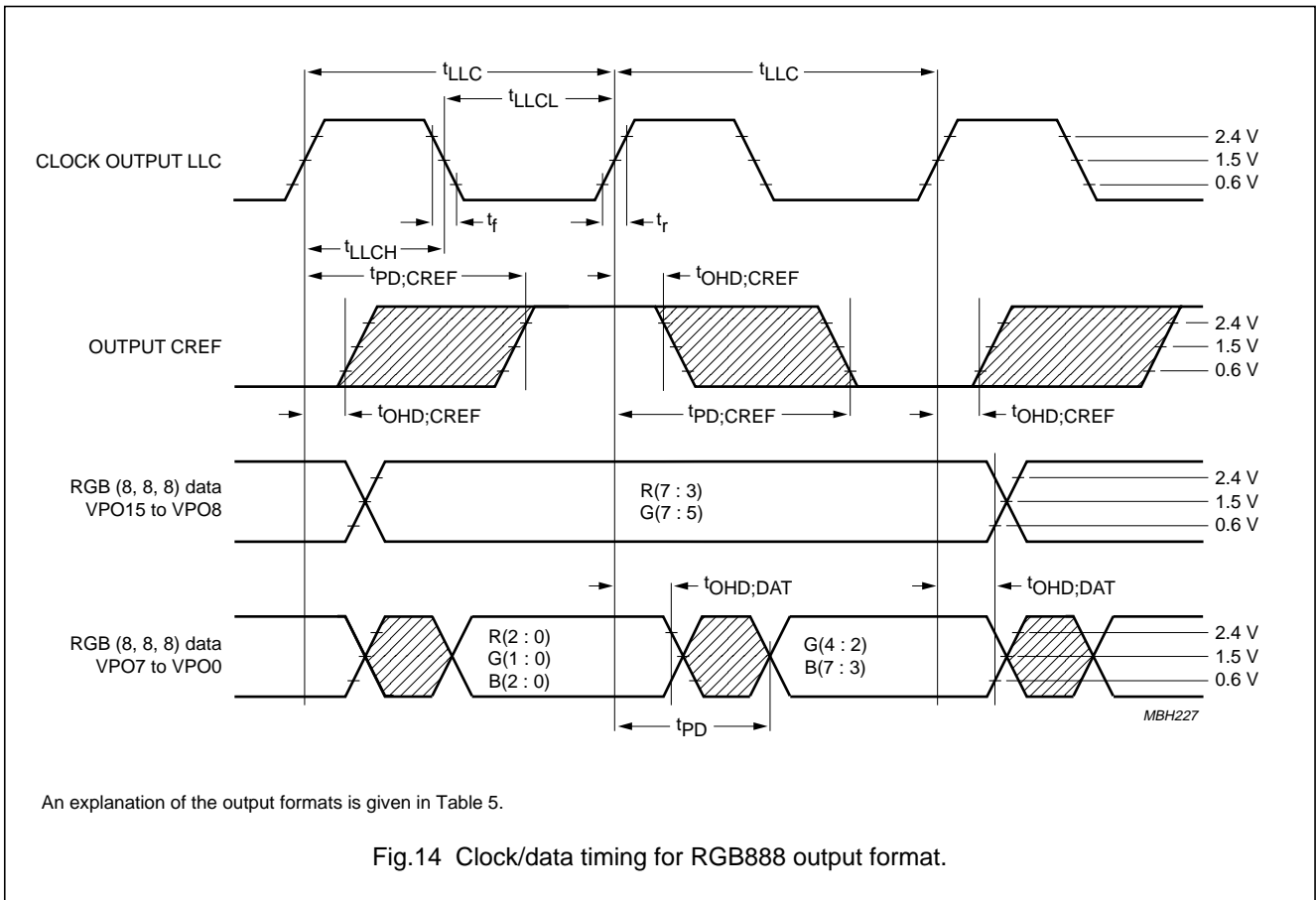



Video Input Processor (VIP)

SAA7111

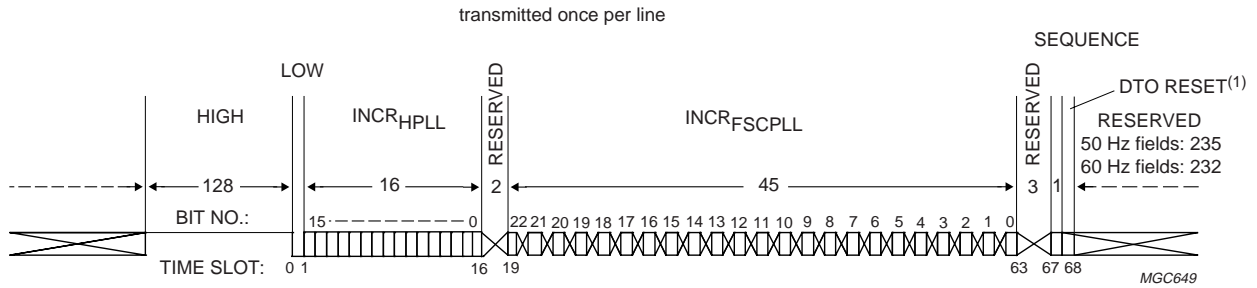

(1) Set to zero for one transmission, if a phase reset of the  $f_{sc}$  - DTO is applied via I<sup>2</sup>C-bit CDTO. RTCO sequence is generated in LLC/4. The HPLL increment represents the actual LFCO frequency ( $f_{LFCO} \times 4 = f_{LLC}$ ); 16 LSB from 20, upper four bits are fixed to 0100b

$$f_{LFCO} = \frac{INCR_{HPLL} \times f_{XTAL}}{2^{\text{word length DTO2}}}$$

Where:  $f_{XTAL} = 24.576$  MHz, word length DTO2 = 20 bits.

The  $f_{sc}$  increment represents the actual subcarrier frequency (related to the actual clock); 23 LSB from 24, MSB is 0b.

$$f_{sc} = \frac{INCR_{FSCPLL} \times f_{XTAL}}{2^{\text{word length DTO1}}} \times \frac{INCR_{HPLL}}{2^{19}}$$

Where: word length DTO1 = 24 bits.

Fig.16 Real time control output.

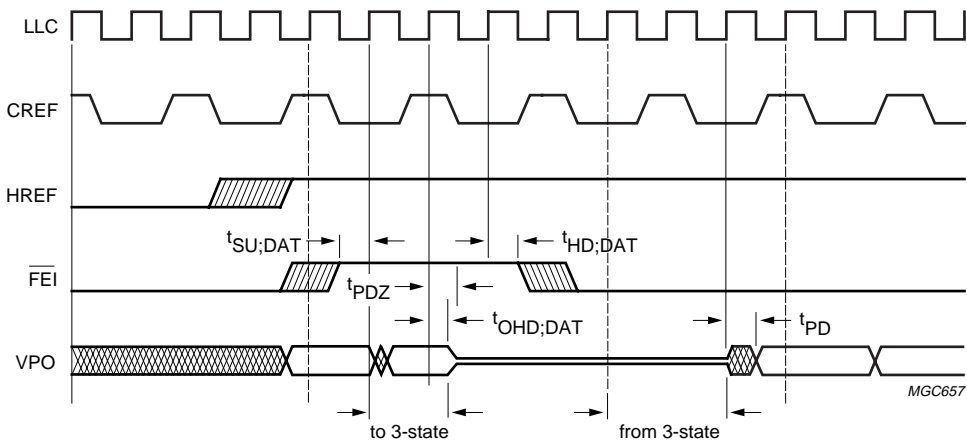

Timing is compatible with SAA7110; I<sup>2</sup>C-bit FECO = 0.

Fig.17 FEI timing diagram (FEI sampling at CREF = LOW).

Video Input Processor (VIP)

SAA7111

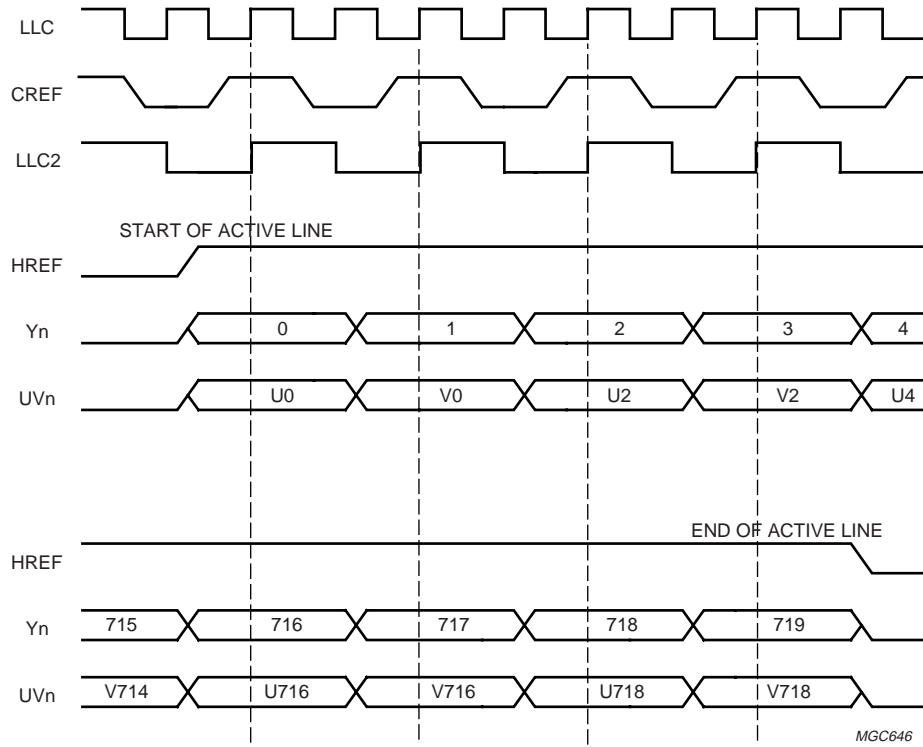
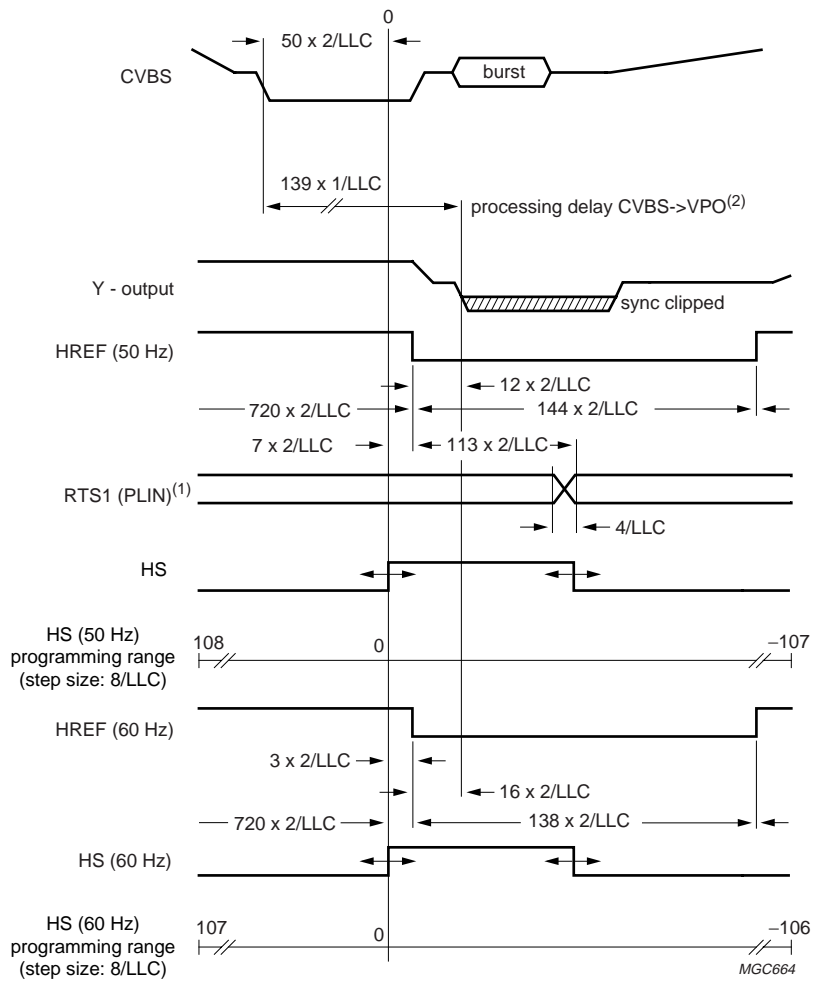

Fig.18 HREF timing diagram.

Video Input Processor (VIP)

SAA7111



(1) PLIN is switched to output RTS1 via I<sup>2</sup>C-bit RTSE1 = 0.  
 (2) See Table 1.

Fig.19 Horizontal timing diagram.

Video Input Processor (VIP)

SAA7111

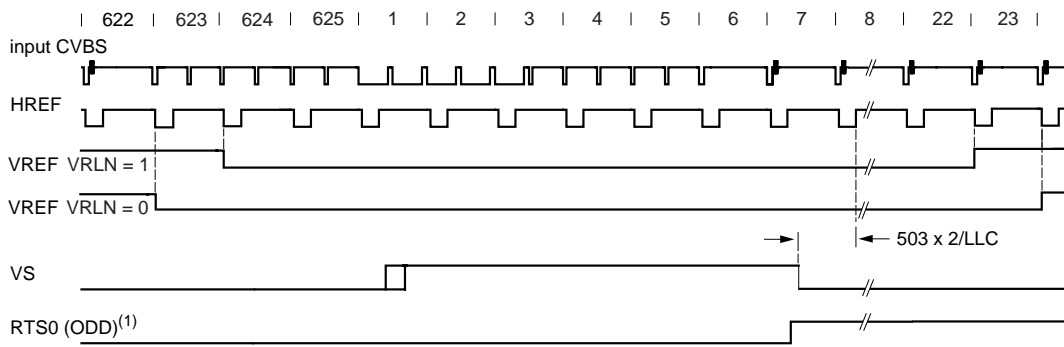

a: 1st field

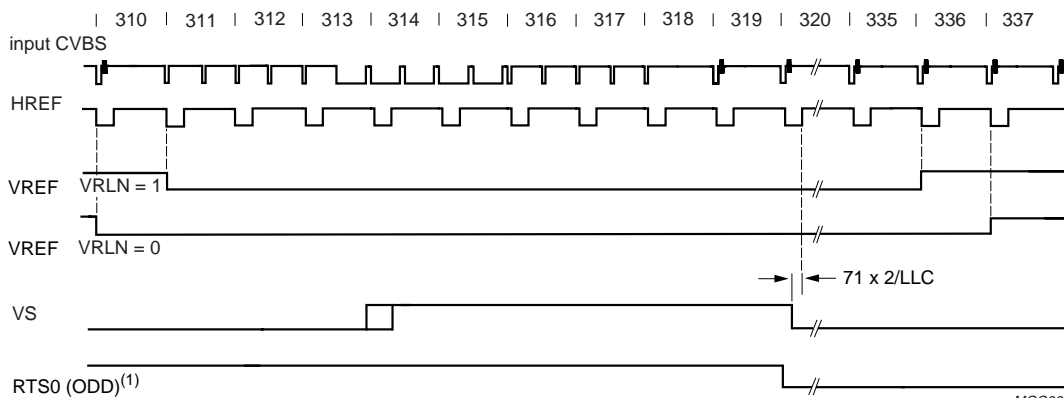

b: 2nd field

MGC662

(1) ODD is switched to output RTS0 via I<sup>2</sup>C-bit RTSE0 = 0.

The luminance peaking and the chrominance trap are bypassed during VREF = 0 if I<sup>2</sup>C-bit VBLB is set to logic 1.

The chrominance delay line (chroma-comb filter for NTSC, phase error correcting for PAL) is disabled during VREF = 0.

Fig.20 Vertical timing diagram for 50 Hz [nominal input signal VNL in normal mode (VNOI = 00b)].

Video Input Processor (VIP)

SAA7111

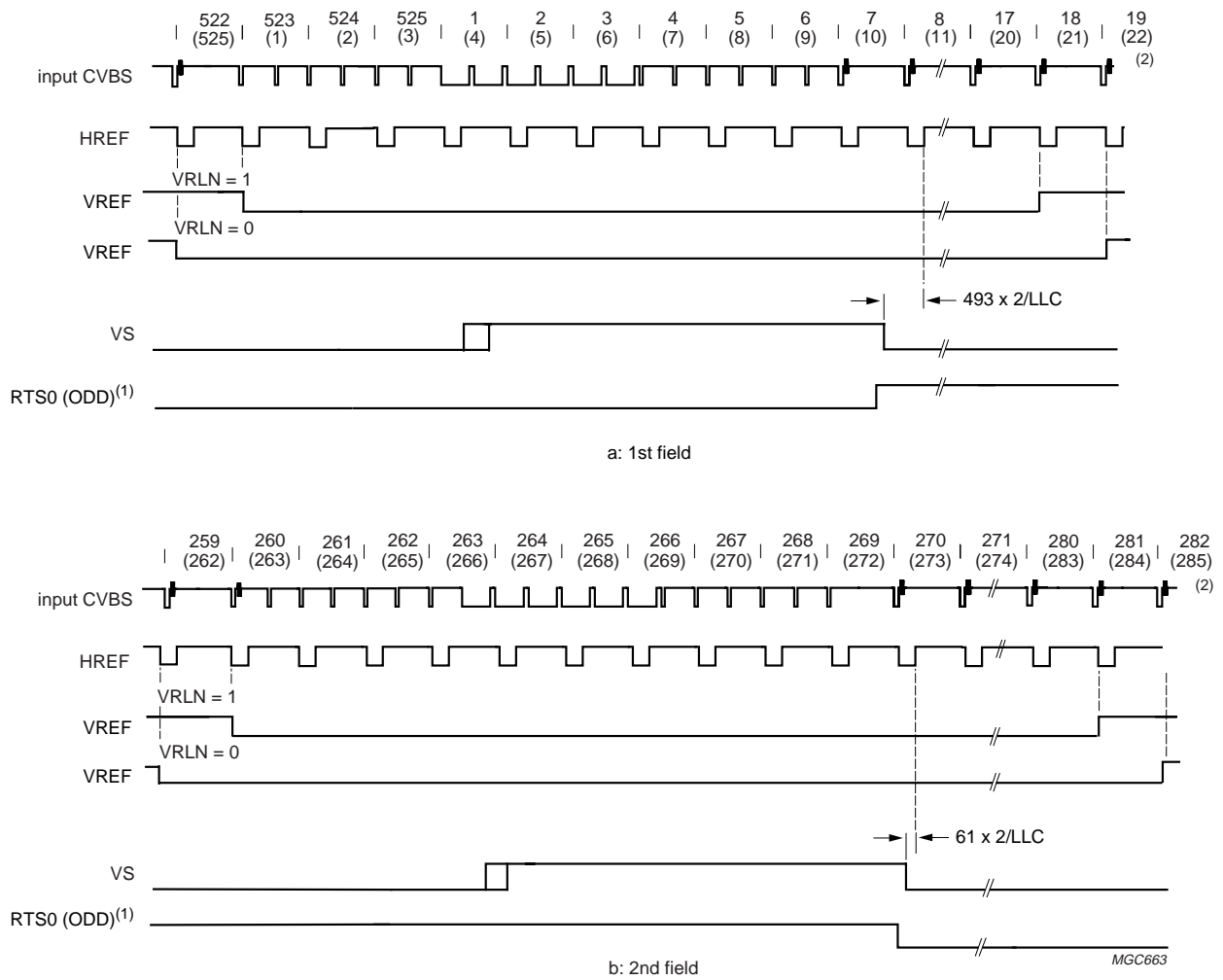

(1) ODD is switched to output RTS0 via I<sup>2</sup>C-bit RTSE0 = 0.

(2) Line numbers in parenthesis refer to CCIR line counting.

The luminance peaking and the chrominance trap are bypassed during VREF = 0 if I<sup>2</sup>C-bit VBLB is set to logic 1.

The chrominance delay line (chroma-comb filter for NTSC, phase error correcting for PAL) is disabled during VREF = 0.

Fig.21 Vertical timing diagram for 60 Hz [nominal input signal VNL in normal mode (VNOI = 00b)].

# Video Input Processor (VIP)

# SAA7111

**Table 2** Digital output control

OEYC	$\overline{FEI}$	VPO		
		15 to 0 <sup>(1)</sup>	15 to 8 <sup>(2)</sup>	7 to 0 <sup>(2)</sup>
0	0	Z	Z	Z
1	0	active	active	Z
0	1	Z	Z	Z
1	1	Z	active	Z

**Table 3** Clock frequencies

CLOCK	FREQUENCY (MHz)
XTAL	24.576
LLC	27
LLC2	13.5
LLC4	6.75
LLC8	3.375

**Notes**

- 1. OFTS(1 : 0) = 10 or 01 or 00.
- 2. OFTS(1 : 0) = 11.

### 13 CLOCK SYSTEM

#### 13.1 Clock generation circuit

The internal CGC generates the system clocks LLC, LLC2 and the clock reference signal CREF. The internal generated LFCO (triangular waveform) is multiplied by 2 or 4 via the analog PLL (including phase detector, loop filter, VCO and frequency divider). The rectangular output signals have a 50% duty factor.

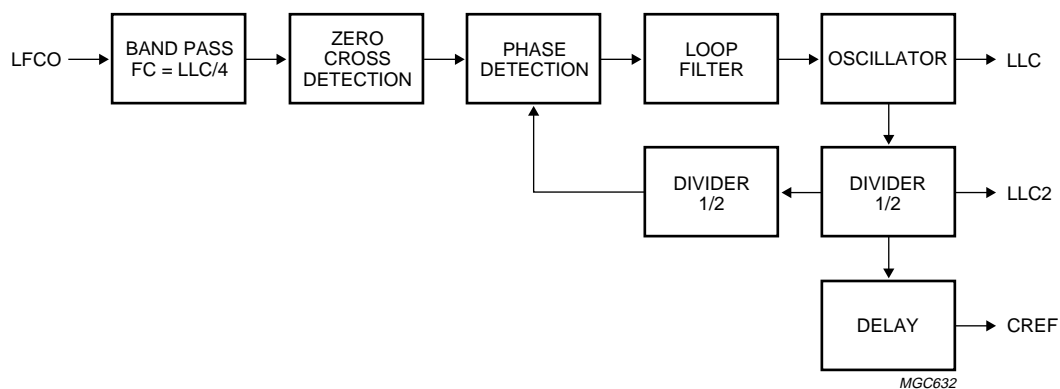

Fig.22 Block diagram of clock generation circuit.

Video Input Processor (VIP)

SAA7111

13.2 Power-on control

Power-on reset is activated at power-on, chip enable, PLL clock generation failure and if the supply voltage falls below 3.5 V. The  $\overline{\text{RES}}$  signal can be applied to reset other circuits of the digital picture processing system.

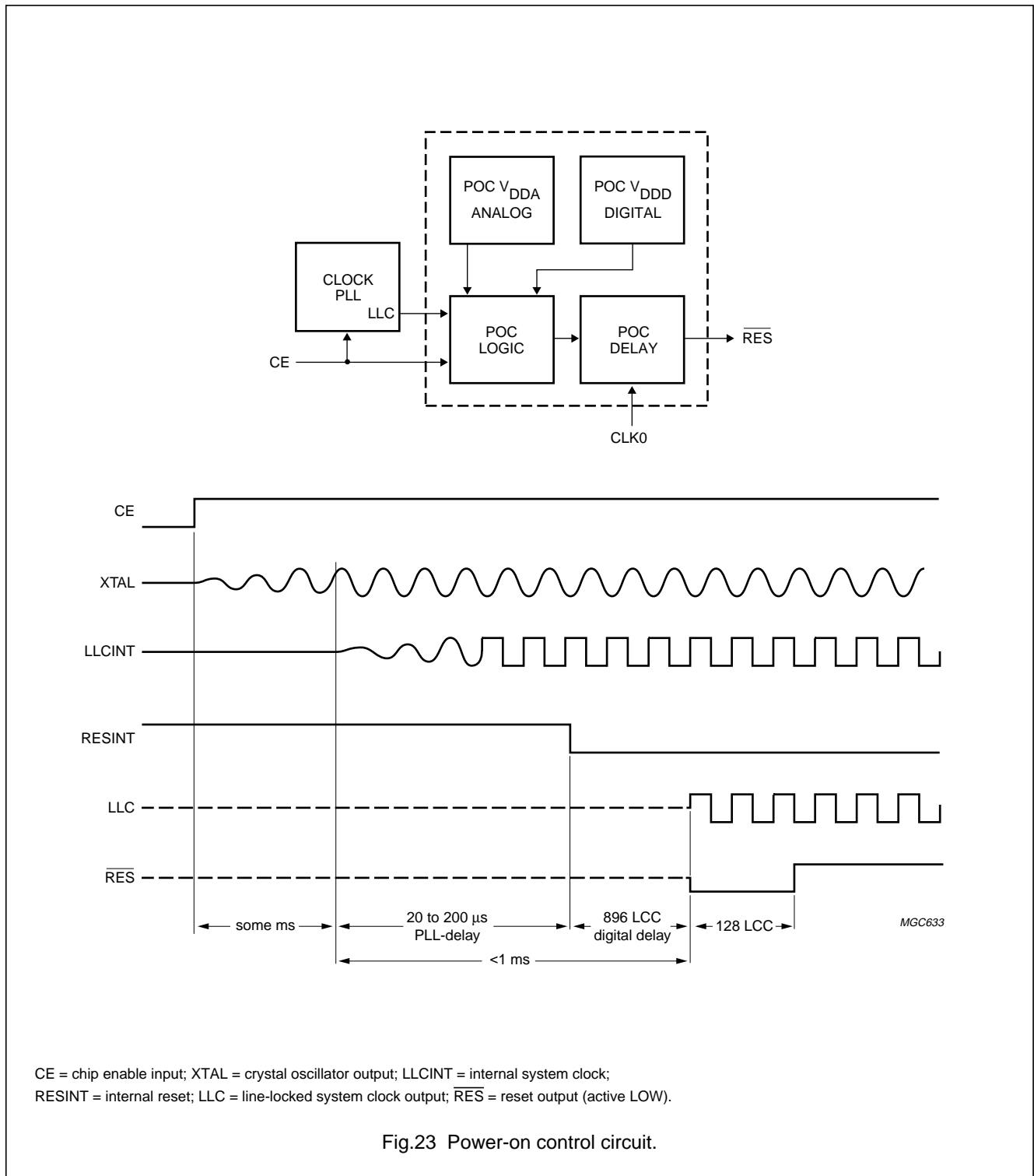

## Video Input Processor (VIP)

## SAA7111

**Table 4** Power-on control sequence

INTERNAL POWER-ON CONTROL SEQUENCE	PIN OUTPUT STATUS	FUNCTION
Directly after power-on asynchronous reset	VPO15 to VPO0, RTCO, RTS0, RTS1, GPSW, HREF, VREF, HS, VS, LLC, LLC2 and CREF are in high-impedance state	direct switching to high impedance for 20 to 200 ms
Synchronous reset sequence	LLC, LLC2, CREF, RTCO, RTS0, RTS1, GPSW and SDA become active; VPO15 to VPO0, HREF, VREF, HS and VS are held in high-impedance state	internal reset sequence
Status after power-on control sequence	VPO15 to VPO0, HREF, VREF, HS and VS are held in high-impedance state	after power-on (reset sequence) a complete I <sup>2</sup> C-bus transmission is required

**14 OUTPUT FORMATS****Table 5** Output formats

BUS SIGNAL	411 (12-BIT)				422 (16-BIT) <sup>(1)</sup>		CCIR-656 (8-BIT) <sup>(2)</sup>				RGB (16-BIT) <sup>(3)</sup>		RGB (24-BIT) <sup>(3)</sup>	
VPO15	Y <sub>07</sub>	Y <sub>17</sub>	Y <sub>27</sub>	Y <sub>37</sub>	Y <sub>07</sub>	Y <sub>17</sub>	U <sub>07</sub>	Y <sub>07</sub>	V <sub>07</sub>	Y <sub>17</sub>	R4	R7	R7	
VPO14	Y <sub>06</sub>	Y <sub>16</sub>	Y <sub>26</sub>	Y <sub>36</sub>	Y <sub>06</sub>	Y <sub>16</sub>	U <sub>06</sub>	Y <sub>06</sub>	V <sub>06</sub>	Y <sub>16</sub>	R3	R6	R6	
VPO13	Y <sub>05</sub>	Y <sub>15</sub>	Y <sub>25</sub>	Y <sub>35</sub>	Y <sub>05</sub>	Y <sub>15</sub>	U <sub>05</sub>	Y <sub>05</sub>	V <sub>05</sub>	Y <sub>15</sub>	R2	R5	R5	
VPO12	Y <sub>04</sub>	Y <sub>14</sub>	Y <sub>24</sub>	Y <sub>34</sub>	Y <sub>04</sub>	Y <sub>14</sub>	U <sub>04</sub>	Y <sub>04</sub>	V <sub>04</sub>	Y <sub>14</sub>	R1	R4	R4	
VPO11	Y <sub>03</sub>	Y <sub>13</sub>	Y <sub>23</sub>	Y <sub>33</sub>	Y <sub>03</sub>	Y <sub>13</sub>	U <sub>03</sub>	Y <sub>03</sub>	V <sub>03</sub>	Y <sub>13</sub>	R0	R3	R3	
VPO10	Y <sub>02</sub>	Y <sub>12</sub>	Y <sub>22</sub>	Y <sub>32</sub>	Y <sub>02</sub>	Y <sub>12</sub>	U <sub>02</sub>	Y <sub>02</sub>	V <sub>02</sub>	Y <sub>12</sub>	G5	G7	G7	
VPO9	Y <sub>01</sub>	Y <sub>11</sub>	Y <sub>21</sub>	Y <sub>31</sub>	Y <sub>01</sub>	Y <sub>11</sub>	U <sub>01</sub>	Y <sub>01</sub>	V <sub>01</sub>	Y <sub>11</sub>	G4	G6	G6	
VPO8	Y <sub>00</sub>	Y <sub>10</sub>	Y <sub>20</sub>	Y <sub>30</sub>	Y <sub>00</sub>	Y <sub>10</sub>	U <sub>00</sub>	Y <sub>00</sub>	V <sub>00</sub>	Y <sub>10</sub>	G3	G5	G5	
VPO7	U <sub>07</sub>	U <sub>05</sub>	U <sub>03</sub>	U <sub>01</sub>	U <sub>07</sub>	V <sub>07</sub>	X	X	X	X	G2	G4	R2	
VPO6	U <sub>06</sub>	U <sub>04</sub>	U <sub>02</sub>	U <sub>00</sub>	U <sub>06</sub>	V <sub>06</sub>	X	X	X	X	G1	G3	R1	
VPO5	V <sub>07</sub>	V <sub>05</sub>	V <sub>03</sub>	V <sub>01</sub>	U <sub>05</sub>	V <sub>05</sub>	X	X	X	X	G0	G2	R0	
VPO4	V <sub>06</sub>	V <sub>04</sub>	V <sub>02</sub>	V <sub>00</sub>	U <sub>04</sub>	V <sub>04</sub>	X	X	X	X	B4	B7	G1	
VPO3	X	X	X	X	U <sub>03</sub>	V <sub>03</sub>	X	X	X	X	B3	B6	G0	
VPO2	X	X	X	X	U <sub>02</sub>	V <sub>02</sub>	X	X	X	X	B2	B5	B2	
VPO1	X	X	X	X	U <sub>01</sub>	V <sub>01</sub>	X	X	X	X	B1	B4	B1	
VPO0	X	X	X	X	U <sub>00</sub>	V <sub>00</sub>	X	X	X	X	B0	B3	B0	
Pixel order Y	0	1	2	3	0	1	0	1			–	note 4	note 5	
Pixel order UV	0				0		0				–		–	
Data rates	LLC2				LLC2		LLC				LLC2		LLC	
I <sup>2</sup> C-bus control signals	OFTS0 = 0				OFTS0 = 1		OFTS0 = 1				OFTS0 = 0		OFTS0 = 0	
	OFTS1 = 1				OFTS1 = 0		OFTS1 = 1				OFTS1 = 0		OFTS1 = 0	
	RGB888 = X				RGB888 = X		RGB888 = X				RGB888 = 0		RGB888 = 1	

**Notes**

- Values in accordance with CCIR-601.
- Before and after the video data, video timing codes are inserted in accordance with CCIR-656.
- Values not defined during HREF = LOW.
- CREF = 0 (see Fig.14).
- CREF = 1 (see Fig.14).



Video Input Processor (VIP)

SAA7111

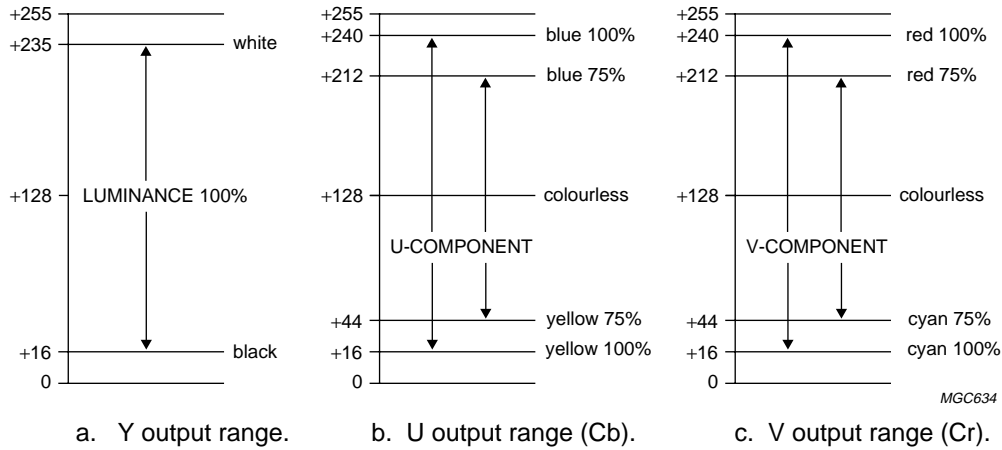

CCIR Rec. 602 digital levels.

Equations for modification to the YUV levels via BCS control I<sup>2</sup>C bytes BRIG, CONT and SATN.

Luminance:

$$Y_{OUT} = \text{Int} \left[ \frac{\text{CONT}}{71} \times (Y - 128) \right] + \text{BRIG}$$

Chrominance:

$$UV_{OUT} = \text{Int} \left[ \frac{\text{SATN}}{64} \times (Cr, Cb - 128) \right] + 128$$

It should be noted that the resulting levels are limited to 1 to 254 in accordance with CCIR-601/656 standard.

Fig.24 VPO output signal range with default BCS settings.

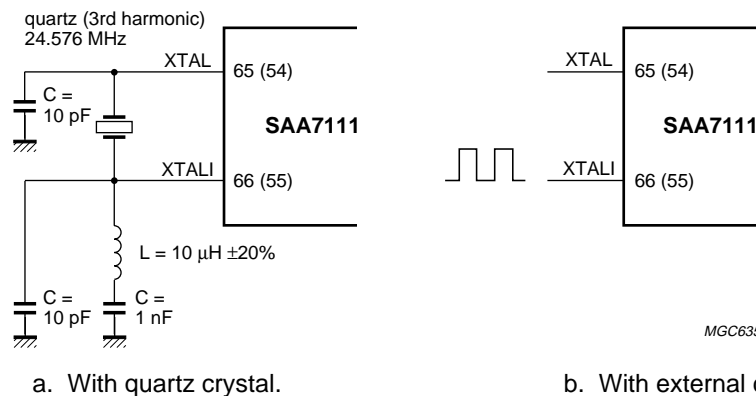

The pin numbers given in parenthesis refer to the 64-pin package.

Fig.25 Oscillator application.

Video Input Processor (VIP)

SAA7111

15 APPLICATION INFORMATION

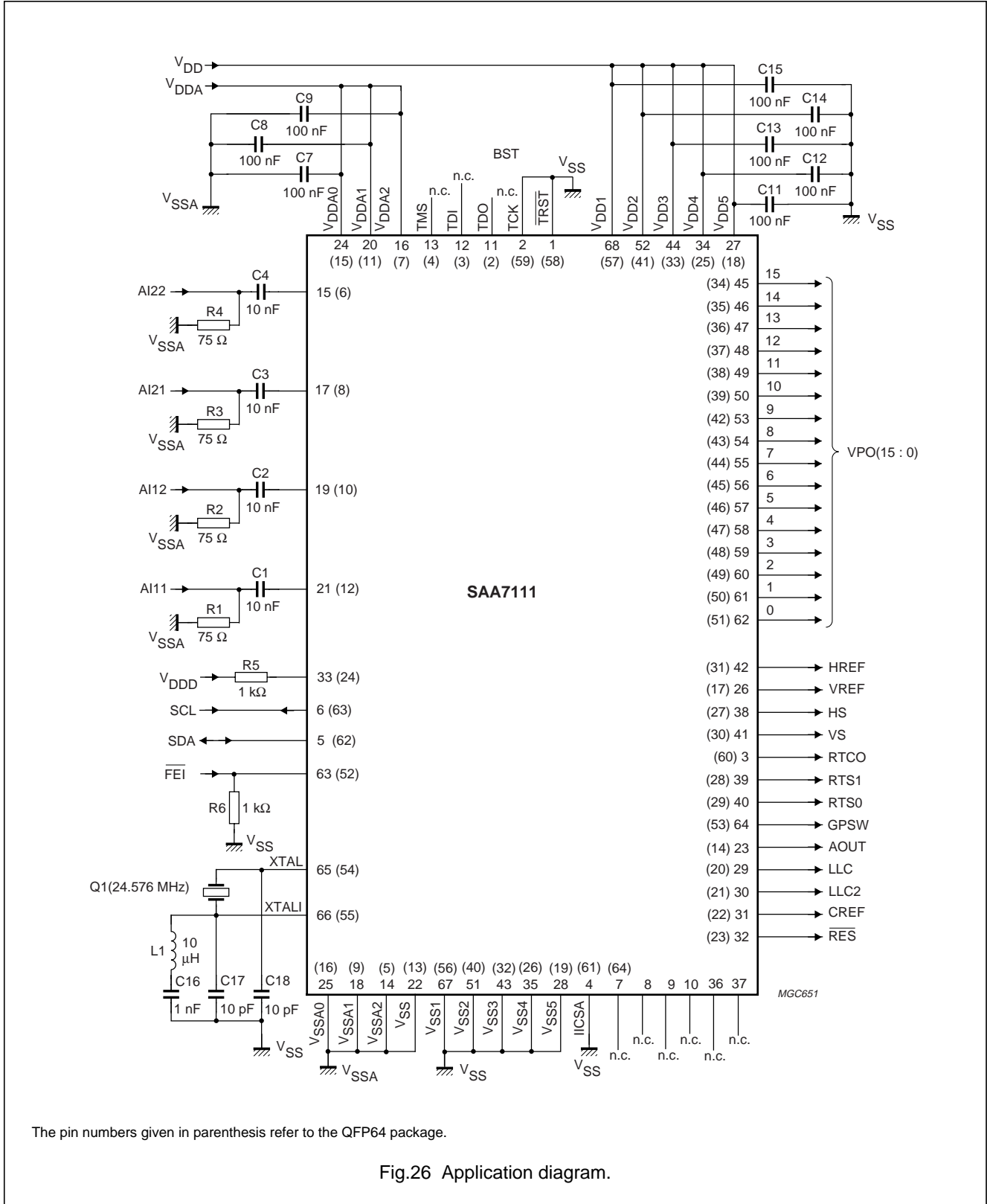

The pin numbers given in parenthesis refer to the QFP64 package.

Fig.26 Application diagram.

Video Input Processor (VIP)

SAA7111

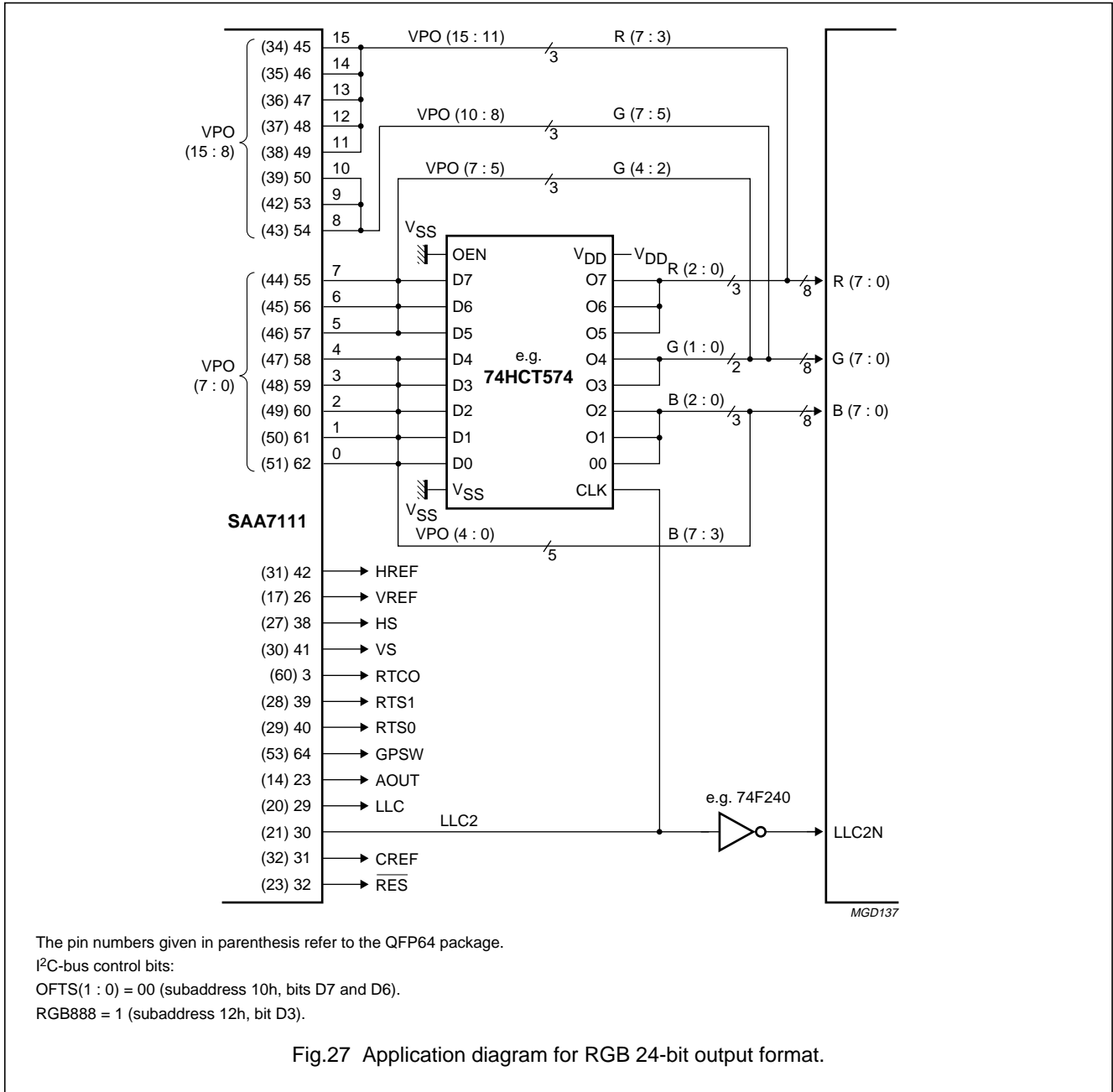

15.1 Layout hints

Use separate ground planes for analog and digital ground. Connect these planes at one point directly under the device, by using a zero Ω resistor. Use separate supply lines for analog and digital supply. Place the supply decoupling capacitors nearby the supply pins.

Place the coupling (clamp) capacitors close to the analog input pins. Place the termination resistors close to the coupling capacitors. Care should be exercised concerning the hidden layout capacitors around the crystal application. To avoid reflection effects use serial resistors in the clock, sync and data lines.

## Video Input Processor (VIP)

SAA7111

**16 I<sup>2</sup>C-BUS DESCRIPTION****16.1 I<sup>2</sup>C-bus format****Table 6** Write procedure

S	SLAVE ADDRESS W	ACK(s)	SUBADDRESS	ACK(s)	DATA (N BYTES)	ACK(s)	P
---	-----------------	--------	------------	--------	----------------	--------	---

**Table 7** Read procedure (combined format)

S	SLAVE ADDRESS W	ACK(s)	SUBADDRESS	ACK(s)		
Sr	SLAVE ADDRESS R	ACK(s)	DATA (N BYTES)	ACK(m)	P	

**Table 8** Description of I<sup>2</sup>C-bus format

CODE	DESCRIPTION	
S	START condition	
Sr	repeated START condition	
Slave address W	0100 1000b (IICSA = LOW) or 0100 1010b (IICSA = HIGH)	
Slave address R	0100 1001b (IICSA = LOW) or 0100 1011b (IICSA = HIGH)	
ACK(s)	acknowledge generated by the slave	
ACK(m)	acknowledge generated by the master	
Subaddress	subaddress byte; see Table 9	
Data	data byte, see; note 1 and Table 9	
P	STOP condition	
X = LSB slave address	read/write control bit; X = 0, order to write (the circuit is slave receiver); X = 1, order to read (the circuit is slave transmitter)	
Slave address	read = 49H or 4BH; note 2	
	write = 48H or 4AH	
	IICSA = 0 or 1	
Subaddress	00H chip version	read and write; note 3
	01H reserved	–
	02H to 05H front-end part	read and write
	06H to 12H decoder part	read and write
	13H to 19H reserved	–
	1AH to 1CH Line-21 text slicer part	read only
	1DH to 1EH reserved	–
	1FH status byte	read only

**Notes**

1. If more than one byte DATA is transmitted then the auto-increment of the subaddress is performed.
2. During slave transmitter mode the SCL-LOW period may be extended by pulling SCL to LOW (in accordance with the I<sup>2</sup>C-bus specification).
3. The I<sup>2</sup>C-bus subaddress 00 has to be initialized with 0 before being read.

## Video Input Processor (VIP)

## SAA7111

**Table 9** I<sup>2</sup>C-bus receiver/transmitter overview

SLAVE ADDRESS		READ		WRITE		IICSA			
		49H and 4BH		48H and 4AH		0 and 1			
REGISTER FUNCTION	SUB-ADDR.	D7	D6	D5	D4	D3	D2	D1	D0
Chip version	00	ID07	ID06	ID05	ID04	ID03	ID02	ID01	ID00
Reserved	01	(1)	(1)	(1)	(1)	(1)	(1)	(1)	(1)
Analog input control 1	02	FUSE1	FUSE0	GUDL2	GUDL1	GUDL0	MODE2	MODE1	MODE0
Analog input control 2	03	(1)	HLNRS	VBSL	WPOFF	HOLDG	GAFIX	GAI28	GAI18
Analog input control 3	04	GAI17	GAI16	GAI15	GAI14	GAI13	GAI12	GAI11	GAI10
Analog input control 4	05	GAI27	GAI26	GAI25	GAI24	GAI23	GAI22	GAI21	GAI20
Horizontal sync start	06	HSB7	HSB6	HSB5	HSB4	HSB3	HSB2	HSB1	HSB0
Horizontal sync stop	07	HSS7	HSS6	HSS5	HSS4	HSS3	HSS2	HSS1	HSS0
Sync control	08	AUFD	FSEL	EXFIL	(1)	VTRC	HPLL	VNOI1	VNOI0
Luminance control	09	BYPS	PREF	BPSS1	BPSS0	VBLB	UPTCV	APER1	APER0
Luminance brightness	0A	BRIG7	BRIG6	BRIG5	BRIG4	BRIG3	BRIG2	BRIG1	BRIG0
Luminance contrast	0B	CONT7	CONT6	CONT5	CONT4	CONT3	CONT2	CONT1	CONT0
Chroma saturation	0C	SATN7	SATN6	SATN5	SATN4	SATN3	SATN2	SATN1	SATN0
Chroma Hue control	0D	HUEC7	HUEC6	HUEC5	HUEC4	HUEC3	HUEC2	HUEC1	HUEC0
Chroma control	0E	CDTO	CM99	CSTD1	CSTD0	DCCF	FCTC	CHBW1	CHBW0
Reserved	0F	(1)	(1)	(1)	(1)	(1)	(1)	(1)	(1)
Format/delay control	10	OFTS1	OFTS0	HDEL1	HDEL0	VRLN	YDEL2	YDEL1	YDEL0
Output control 1	11	GPSW	(1)	FECO	COMPO	OEYC	OEHV	VIPB	COLO
Output control 2	12	RTSE1	RTSE0	(1)	CBR	RGB888	DIT	AOSL1	AOSL0
Reserved	13-19	(1)	(1)	(1)	(1)	(1)	(1)	(1)	(1)
Text slicer status	1A	(1)	(1)	(1)	(1)	F2VAL	F2RDY	F1VAL	F1RDY
Decoded bytes of the text slicer	1B	P1	BYTE16	BYTE15	BYTE14	BYTE13	BYTE12	BYTE11	BYTE10
	1C	P2	BYTE26	BYTE25	BYTE24	BYTE23	BYTE22	BYTE21	BYTE20
Reserved	1D-1E	(1)	(1)	(1)	(1)	(1)	(1)	(1)	(1)
Status byte	1F	STTC	HLCK	FIDT	GLIMT	GLIMB	WIPA	SLTCA	CODE

**Note**

1. All unused control bits must be programmed with 0.

**16.2 I<sup>2</sup>C-bus detail**

The I<sup>2</sup>C-bus receiver slave address is 48H/49H. Subaddresses 0F, 1D, 1E and 13 to 19 are reserved; subaddress 01 is reserved for chip version.

## Video Input Processor (VIP)

SAA7111

## 16.2.1 SUBADDRESS 00

**Table 10** Chip version SA 00, D7 to D0

FUNCTION	CONTROL BITS							
	ID07	ID06	ID05	ID04	ID03	ID02	ID01	ID00
Chip version in read mode <sup>(1)</sup>	0	0	0	0	X	X	X	X
	chip version number				reserved for chip name			

**Note**

- The I<sup>2</sup>C-bus subaddress 00 has to be initialized with 0 prior to reading it.

## 16.2.2 SUBADDRESS 02

**Table 11** Analog control 1 (mode select; see Figs 28 to 35) SA 02, D2 to D0; note 1

FUNCTION	CONTROL BITS D2 TO D0		
	MODE 2	MODE 1	MODE 0
Mode 0: CVBS (automatic gain)	0	0	0
Mode 1: CVBS (automatic gain)	0	0	1
Mode 2: CVBS (automatic gain)	0	1	0
Mode 3: CVBS (automatic gain)	0	1	1
Mode 4: Y (automatic gain) + C (gain channel 2 fixed to GAI2 level)	1	0	0
Mode 5: Y (automatic gain) + C (gain channel 2 fixed to GAI2 level)	1	0	1
Mode 6: Y (automatic gain) + C (gain channel 2 adapted to Y gain)	1	1	0
Mode 7: Y (automatic gain) + C (gain channel 2 adapted to Y gain)	1	1	1

**Note**

- For modes 0 to 3 use BYPS (SA 09, D7) = 0 (chrominance trap active) and for modes 4 to 7 use BYPS = 1 (chrominance trap bypassed).

**Table 12** Analog control 1 SA 02, D5 to D3 (see Fig.11)

DECIMAL VALUE	UPDATE HYSTERESIS FOR 9-BIT GAIN	CONTROL BITS D5 TO D3		
		GUDL 2	GUDL 1	GUDL 0
0....	off	0	0	0
....7	±7 LSB	1	1	1

**Table 13** Analog control 1 SA 02, D7 and D6

ANALOG FUNCTION SELECT FUSE	CONTROL BITS D7 AND D6	
	FUSE 1	FUSE 0
Amplifier plus anti-alias filter bypassed	0	0
	0	1
Amplifier active	1	0
Amplifier plus anti-alias filter active	1	1

Video Input Processor (VIP)

SAA7111

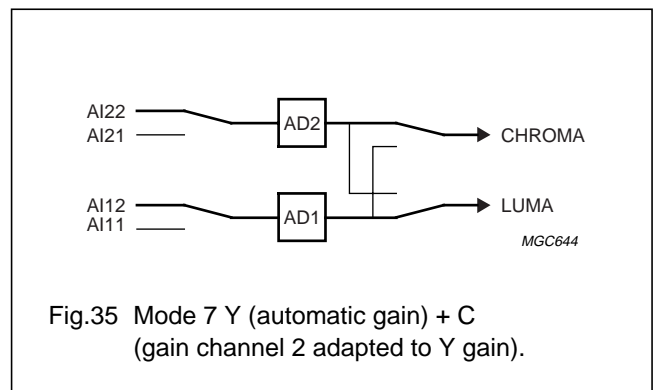
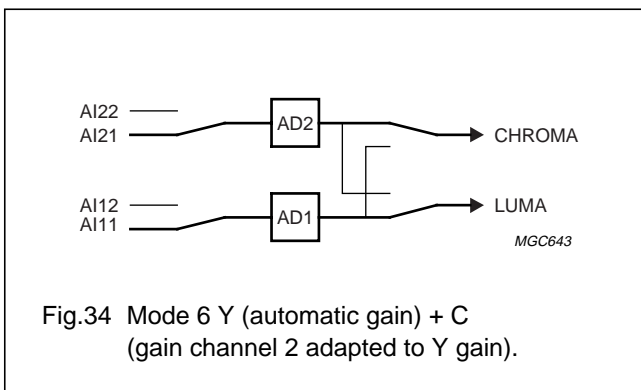
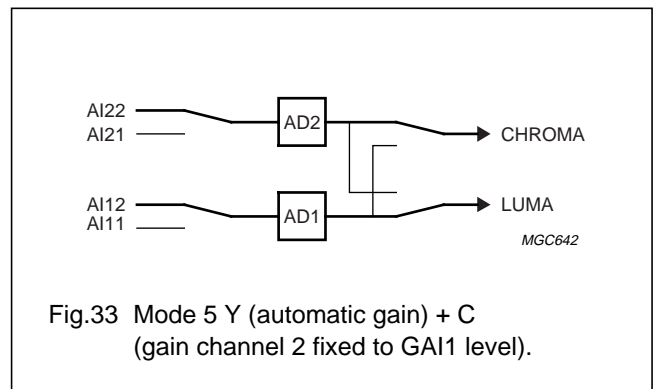
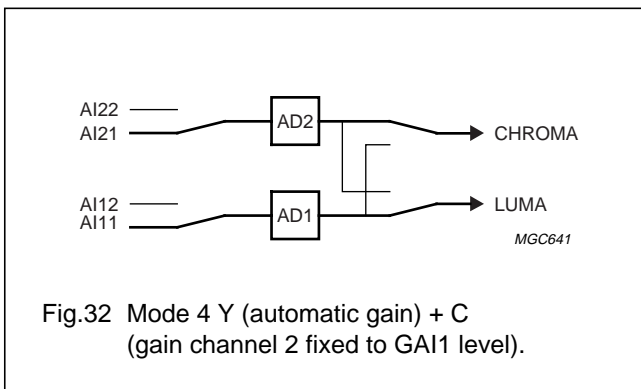
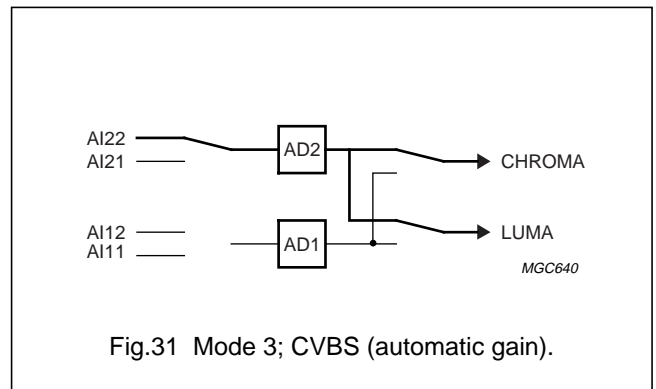
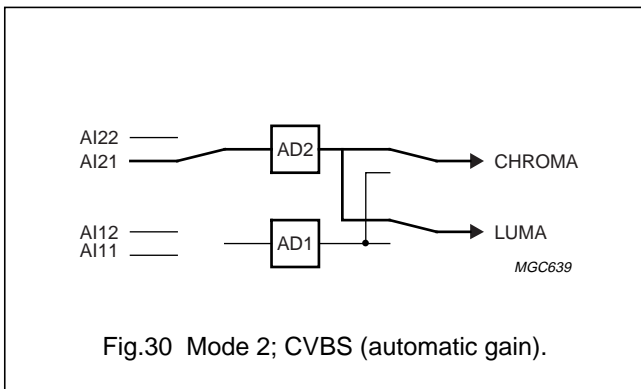
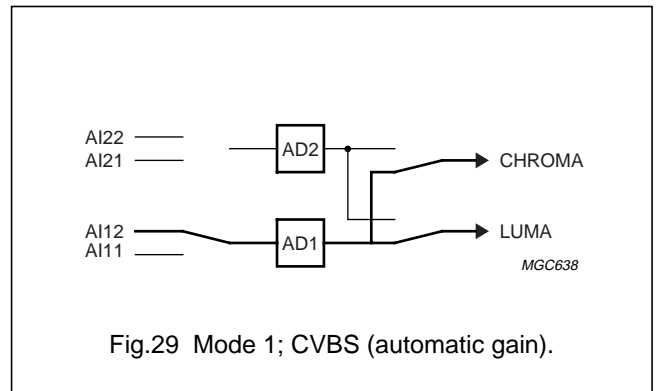
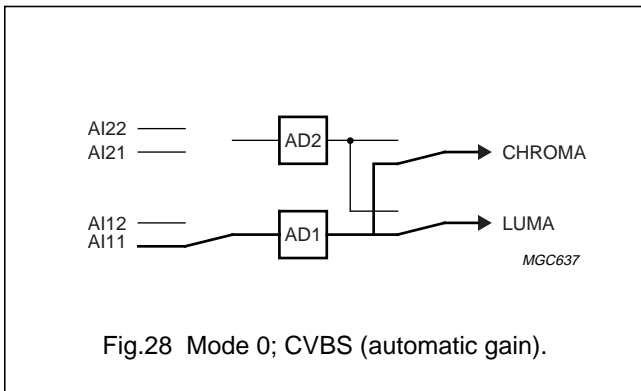

## Video Input Processor (VIP)

SAA7111

## 16.2.3 SUBADDRESS 03

**Table 14** Analog control 2 (AICO2)

FUNCTION	BIT NAME	LOGIC LEVEL	CONTROL BIT
<b>Static gain control channel 1 (GAI18)</b>			
Sign bit of gain control	GAI18	see Table 15	D0
<b>Static gain control channel 2 (GAI28)</b>			
Sign bit of gain control	GAI28	see Table 16	D1
<b>Gain control fix (GAFIX)</b>			
Automatic gain controlled by MODE 1 and MODE 0	GAFIX	0	D2
Gain control is user programmable via GAI1 + GAI2	GAFIX	1	D2
<b>Automatic gain control integration (HOLDG)</b>			
AGC active	HOLDG	0	D3
AGC integration hold (freeze)	HOLDG	1	D3
<b>White peak off (WPOFF)</b>			
White peak control active	WPOFF	0	D4
White peak off	WPOFF	1	D4
<b>Vertical blanking select (VBSL)</b>			
Long vertical blanking	VBSL	0	D5
Short vertical blanking	VBSL	1	D5
<b>HL not reference select (HLNRS)</b>			
Normal clamping by HL not	HLNRS	0	D6
Reference select by HL not	HLNRS	1	D6

## 16.2.4 SUBADDRESS 04

**Table 15** Gain control analog (AIC03); static gain control channel 1 GAI1 SA 04, D7 to D0

DECIMAL VALUE	GAIN (dB)	SIGN BIT	CONTROL BITS D7 TO D0							
		GAI18	GAI17	GAI16	GAI15	GAI14	GAI13	GAI12	GAI11	GAI10
0....	-5.98	0	0	0	0	0	0	0	0	0
....255	0	0	1	1	1	1	1	1	1	1
256....	0	1	0	0	0	0	0	0	0	0
....511	5.98	1	1	1	1	1	1	1	1	1



## Video Input Processor (VIP)

## SAA7111

## 16.2.5 SUBADDRESS 05

**Table 16** Gain control analog (AIC04); static gain control channel 2 GAI2 SA 05

DECIMAL VALUE	GAIN (dB)	SIGN BIT (SA 03, D1)	CONTROL BITS D7 to D0							
			GAI28	GAI27	GAI26	GAI25	GAI24	GAI23	GAI22	GAI21
0....	-5.98	0	0	0	0	0	0	0	0	0
....255	0	0	1	1	1	1	1	1	1	1
256....	0	1	0	0	0	0	0	0	0	0
....511	5.98	1	1	1	1	1	1	1	1	1

## 16.2.6 SUBADDRESS 06

**Table 17** Horizontal sync begin SA 06, D7 to D0

DELAY TIME (STEP SIZE = 8/LLC)	CONTROL BITS D7 to D0								
	HSB7	HSB6	HSB5	HSB4	HSB3	HSB2	HSB1	HSB0	
-128...-108	forbidden (outside available central counter range)								
-107...	1	0	0	1	0	1	0	1	
...108 (50 Hz)	0	1	1	0	1	1	0	0	
...107 (60 Hz)	0	1	1	0	1	0	1	1	
109...127 (50 Hz) 108...127 (60 Hz)	forbidden (outside available central counter range)								

## 16.2.7 SUBADDRESS 07

**Table 18** Horizontal sync stop SA 07

DELAY TIME (STEP SIZE = 8/LLC)	CONTROL BITS D7 to D0								
	HSS7	HSS6	HSS5	HSS4	HSS3	HSS2	HSS1	HSS0	
-128...-108	forbidden (outside available central counter range)								
-107...	1	0	0	1	0	1	0	1	
...108 (50 Hz)	0	1	1	0	1	1	0	0	
...107 (60 Hz)	0	1	1	0	1	0	1	1	
109...127 (50 Hz) 108...127 (60 Hz)	forbidden (outside available central counter range)								

## Video Input Processor (VIP)

SAA7111

## 16.2.8 SUBADDRESS 08

**Table 19** Sync control SA 08, D7 to D5, D3 to D0

FUNCTION	BIT NAME	LOGIC LEVEL	CONTROL BIT
<b>Vertical noise reduction (VNOI)</b>			
Normal mode	VNOI1	0	D1
	VNOI0	0	D0
Searching mode	VNOI1	0	D1
	VNOI0	1	D0
Free running mode	VNOI1	1	D1
	VNOI0	0	D0
Vertical noise reduction bypassed	VNOI1	1	D1
	VNOI0	1	D0
<b>Horizontal PLL (HPLL)</b>			
PLL closed	HPLL	0	D2
PLL open, horizontal frequency fixed	HPLL	1	D2
<b>TV/VTR mode select (VTRC)</b>			
TV mode (recommended for poor quality TV signals only)	VTRC	0	D3
VTR mode (recommended as default setting)	VTRC	1	D3
<b>Extended loop filter (EXFIL)</b>			
Word width of the loop filter (LF2) amplification = 16-bit	EXFIL	0	D5
Word width of the loop filter (LF2) amplification = 14-bit	EXFIL	1	D5
<b>Field selection (FSEL)</b>			
50 Hz and 625 lines	FSEL	0	D6
60 Hz and 525 lines	FSEL	1	D6
<b>Automatic field detection (AUFD)</b>			
Field state directly controlled via FSEL	AUFD	0	D7
Automatic field detection	AUFD	1	D7

## Video Input Processor (VIP)

SAA7111

## 16.2.9 SUBADDRESS 09

**Table 20** Luminance control

FUNCTION	BIT NAME	LOGIC LEVEL	CONTROL BIT
<b>Aperture factor (APER)</b>			
Aperture factor = 0	APER1	0	D1
	APER0	0	D0
Aperture factor = 0.25	APER1	0	D1
	APER0	1	D0
Aperture factor = 0.5	APER1	1	D1
	APER0	0	D0
Aperture factor = 1.0	APER1	1	D1
	APER0	1	D0
<b>Update time interval for AGC value (UPTCV)</b>			
Horizontal update (once per line)	UPTCV	0	D2
Vertical update (once per field)	UPTCV	1	D2
<b>Vertical blanking luminance bypass (VBLB)</b>			
Active luminance processing	VBLB	0	D3
Luminance bypass during vertical blanking	VBLB	1	D3
<b>Aperture band-pass (centre frequency) (BPSS) D5 and D4</b>			
Centre frequency = 4.1 MHz	BPSS1	0	D5
	BPSS0	0	D4
Centre frequency = 3.8 MHz; note 1	BPSS1	0	D5
	BPSS0	1	D4
Centre frequency = 2.6 MHz; note 1	BPSS1	1	D5
	BPSS0	0	D4
Centre frequency = 2.9 MHz; note 1	BPSS1	1	D5
	BPSS0	1	D4
<b>Prefilter active (PREF)</b>			
Bypassed	PREF	0	D6
Active	PREF	1	D6
<b>Chrominance trap bypass (BYPS)</b>			
Chrominance trap active; default for CVBS mode	BYPS	0	D7
Chrominance trap bypassed; default for S-Video mode	BYPS	1	D7

**Note**

1. Not to be used with bypassed chrominance trap.

## Video Input Processor (VIP)

## SAA7111

## 16.2.10 SUBADDRESS 0A

**Table 21** Luminance brightness control BRIG7 to BRIG0 SA 0A

OFFSET	CONTROL BITS D7 to D0							
	BRIG7	BRIG6	BRIG5	BRIG4	BRIG3	BRIG2	BRIG1	BRIG0
255 (bright)	1	1	1	1	1	1	1	1
128 (CCIR level)	1	0	0	0	0	0	0	0
0 (dark)	0	0	0	0	0	0	0	0

## 16.2.11 SUBADDRESS 0B

**Table 22** Luminance contrast control CONT7 to CONT0 SA 0B

GAIN	CONTROL BITS D7 to D0							
	CONT7	CONT6	CONT5	CONT4	CONT3	CONT2	CONT1	CONT0
1.999 (maximum)	0	1	1	1	1	1	1	1
1.109 (CCIR level)	0	1	0	0	0	1	1	1
1.0	0	1	0	0	0	0	0	0
0 (luminance off)	0	0	0	0	0	0	0	0
-1 (inverse luminance)	1	1	0	0	0	0	0	0
-2 (inverse luminance)	1	0	0	0	0	0	0	0

## 16.2.12 SUBADDRESS 0C

**Table 23** Chrominance saturation control SATN7 to SATN0 SA 0C

GAIN	CONTROL BITS D7 to D0							
	SATN7	SATN6	SATN5	SATN4	SATN3	SATN2	SATN1	SATN0
1.999 (maximum)	0	1	1	1	1	1	1	1
1.0 (CCIR level)	0	1	0	0	0	0	0	0
0 (colour off)	0	0	0	0	0	0	0	0
-1 (inverse chroma)	1	1	0	0	0	0	0	0
-2 (inverse chroma)	1	0	0	0	0	0	0	0

## 16.2.13 SUBADDRESS 0D

**Table 24** Chrominance hue control HUEC7 to HUEC0 SA 0D

HUE PHASE (DEG)	CONTROL BITS D7 to D0							
	HUEC7	HUEC6	HUEC5	HUEC4	HUEC3	HUEC2	HUEC1	HUEC0
+178.6....	0	1	1	1	1	1	1	1
....0....	0	0	0	0	0	0	0	0
....-180	1	0	0	0	0	0	0	0

## Video Input Processor (VIP)

SAA7111

## 16.2.14 SUBADDRESS 0E

Table 25 Chrominance control SA 0E

FUNCTION	BIT NAME	LOGIC LEVEL	CONTROL BIT
<b>Chroma bandwidth (CHBW0 and CHBW1)</b>			
Small bandwidth ( $\approx 620$ kHz)	CHBW1	0	D1
	CHBW0	0	D0
Nominal bandwidth ( $\approx 800$ kHz)	CHBW1	0	D1
	CHBW0	1	D0
Medium bandwidth ( $\approx 920$ kHz)	CHBW1	1	D1
	CHBW0	0	D0
Wide bandwidth ( $\approx 1\,000$ kHz)	CHBW1	1	D1
	CHBW0	1	D0
<b>Fast colour time constant (FCTC)</b>			
Nominal time constant	FCTC	0	D2
Fast time constant	FCTC	1	D2
<b>Disable chroma comb filter (DCCF)</b>			
Chroma comb filter on (during VREF = 1) (see Figures 20 and 21)	DCCF	0	D3
Chroma comb filter off	DCCF	1	D3
<b>Colour standard (CSTD0 and CSTD1)</b>			
Colour standard control automatic switching between PAL BGHI and NTSC M	CSTD1	0	D5
	CSTD0	0	D4
Colour standard control automatic switching between NTSC 4.43 (50 Hz) and PAL 4.43 (60 Hz)	CSTD1	0	D5
	CSTD0	1	D4
Colour standard control automatic switching between PAL N and NTSC 4.43 (60 Hz)	CSTD1	1	D5
	CSTD0	0	D4
Colour standard control automatic switching between NTSC N and PAL M	CSTD1	1	D5
	CSTD0	1	D4
<b>Compatibility to SAA7199 (CM99)</b>			
Default value	CM99	0	D6
To be set if SAA7199 (digital encoder) is used for re-encoding in conjunction with RTCO	CM99	1	D6
<b>Clear DTO (CDTO)</b>			
Disabled	CDTO	0	D7
Every time CDTO is set, the internal subcarrier DTO phase is reset to $0^\circ$ and the RTCO output generates a logic 0 at time slot 68 (see RTCO description Fig.16). So an identical subcarrier phase can be generated by an external device (e.g. an encoder).	CDTO	1	D7

## Video Input Processor (VIP)

SAA7111

## 16.2.15 SUBADDRESS 10

**Table 26** Format/delay control SA 10

LUMINANCE DELAY COMPENSATION (STEPS IN 2/LLC)	CONTROL BITS D2 to D0		
	YDEL2	YDEL1	YDEL0
-4...	1	0	0
...0...	0	0	0
...3	0	1	1

**Table 27** VREF pulse position and length VRLN SA 10 (D3)

VRLN	VREF at 60 HZ 525 LINES <sup>(1)</sup>				VREF at 50 HZ 625 LINES			
	0		1		0		1	
Length	240		242		286		288	
Line number	first	last	first	last	first	last	first	last
Field 1	19 (22)	258 (261)	18 (21)	259 (262)	24	309	23	310
Field 2	282 (285)	521 (524)	281 (284)	522 (525)	337	622	336	623

**Note**

1. The numbers given in parenthesis refer to CCIR line counting.

**Table 28** Fine position of HS HDEL0 and HDEL1 SA 10

FINE POSITION OF HS WITH A STEP SIZE OF 2/LLC	CONTROL BITS D5 and D4	
	HDEL1	HDEL0
0	0	0
1	0	1
2	1	0
3	1	1

**Table 29** Output format selection OFTS0 and OFTS1 SA 10

FORMATS	CONTROL BITS D7 and D6	
	OFTS1	OFTS0
RGB 565, RGB 888 (dependent on control bit RGB888) see Table 31	0	0
YUV 422 16 bits	0	1
YUV 411 12 bits	1	0
YUV CCIR-656 8 bits	1	1

## Video Input Processor (VIP)

SAA7111

## 16.2.16 SUBADDRESS 11

**Table 30** Output control 1 SA 11

FUNCTION	BIT NAME	LOGIC LEVEL	CONTROL BIT
<b>Colour on (COLO)</b>			
Automatic colour killer	COLO	0	D0
Colour forced on	COLO	1	D0
<b>Decoder VIP bypassed (VIPB)</b>			
DMSD data to YUV output	VIPB	0	D1
ADC data to YUV output; dependent on mode settings	VIPB	1	D1
<b>Output enable horizontal/vertical sync (OEHV)</b>			
HS, HREF, VREF and VS high impedance inputs	OEHV	0	D2
Outputs HS, HREF, VREF and VS active	OEHV	1	D2
<b>Output enable YUV data (OEYC)</b>			
VPO-bus high-impedance inputs	OEYC	0	D3
Output VPO-bus active	OEYC	1	D3
<b>Inverse composite blank (COMPO)</b>			
VREF is vertical reference	COMPO	0	D4
VREF is inverse composite blank	COMPO	1	D4
<b>FEI control (FECO)</b>			
$\overline{\text{FEI}}$ sampling at CREF = LOW (SAA7110 compatible; see Fig.17)	FECO	0	D5
$\overline{\text{FEI}}$ sampling at CREF = HIGH	FECO	1	D5
<b>General purpose switch (GPSW)</b>			
Switches directly pin 64 (53) GPSW; note 1	GPSW	0	D7
	GPSW	1	D7

**Note**

1. The pin number given in parenthesis refers to the 64-pin package.

## Video Input Processor (VIP)

SAA7111

## 16.2.17 SUBADDRESS 12

**Table 31** Output control 2 SA 12

FUNCTION	BIT NAME	LOGIC LEVEL	CONTROL BIT
<b>Analog test select (AOSL)</b>			
AOUT connected to internal test point 1	AOSL1	0	D1
	AOSL0	0	D0
AOUT connected to input AD1	AOSL1	0	D1
	AOSL0	1	D0
AOUT connected to input AD2	AOSL1	1	D1
	AOSL0	0	D0
AOUT connected to internal test point 2	AOSL1	1	D1
	AOSL0	1	D0
<b>Dithering (noise shaping) control (DIT)</b>			
Dithering off	DIT	0	D2
Dithering on	DIT	1	D2
<b>RGB output format selection (RGB888)</b>			
RGB565	RGB888	0	D3
RGB888	RGB888	1	D3
<b>Chroma interpolation filter function (CBR)</b>			
Cubic interpolation (default)	CBR	0	D4
Linear interpolation (lower bandwidth)	CBR	1	D4
<b>Real time outputs mode select (RTSE0)</b>			
ODD switched to output pin 40 (29); note 1	RTSE0	0	D6
VL switched to output pin 40 (29); note 1	RTSE0	1	D6
<b>Real time outputs mode select (RTSE1)</b>			
PLIN switched to output pin 39 (28); note 1	RTSE1	0	D7
HL switched to output pin 39 (28); note 1	RTSE1	1	D7

**Note**

1. The pin number given in parenthesis refers to the 64-pin package.



## Video Input Processor (VIP)

## SAA7111

## 16.2.18 SUBADDRESS 1A (READ-ONLY REGISTER)

**Table 32** Line-21 text slicer status SA 1A

I <sup>2</sup> C-BUS STATUS BIT NAME	FUNCTION	STATUS BIT
F1RDY	new data on field 1 has been acquired (for asynchronous reading); active HIGH	D0
F1VAL	Line-21 of field 1 carries valid data; active HIGH	D1
F2RDY	new data on field 2 has been acquired (for asynchronous reading); active HIGH	D2
F2VAL	Line-21 of field 2 carries valid data; active HIGH	D3

## 16.2.19 SUBADDRESS 1B (READ-ONLY REGISTER)

**Table 33** First decoded data byte of the text slicer SA 1B

I <sup>2</sup> C-BUS TEXT DATA BITS	FUNCTION	DATA BITS
BYTE1 (6 to 0)	data bit 6 to 0 of first data byte	D6 to D0
P1	parity error flag bit; bit goes HIGH when a parity error has occurred	D7

## 16.2.20 SUBADDRESS 1C (READ-ONLY REGISTER)

**Table 34** Second decoded data byte of the text slicer SA 1C

I <sup>2</sup> C-BUS TEXT DATA BITS	FUNCTION	DATA BITS
BYTE2 (6 to 0)	data bit 6 to 0 of second data byte	D6 to D0
P2	parity error flag bit; bit goes HIGH when a parity error has occurred	D7

## 16.2.21 SUBADDRESS 1F (READ-ONLY REGISTER)

**Table 35** Status byte SA 1F

I <sup>2</sup> C-BUS STATUS BIT NAME	FUNCTION	STATUS BIT
CODE	colour signal according to selected standard has been detected; active HIGH	D0
SLTCA	slow time constant active in WIPA-mode; active HIGH	D1
WIPA	white peak loop is activated; active HIGH	D2
GLIMB	gain value for active luminance channel is limited [min (bottom)]; active HIGH	D3
GLIMT	gain value for active luminance channel is limited [max (top)]; active HIGH	D4
FIDT	identification bit for detected field frequency; LOW = 50 Hz and HIGH = 60 Hz	D5
HLCK	status bit for locked horizontal frequency; LOW = locked and HIGH = unlocked	D6
STTC	status bit for horizontal phase loop; LOW = TV time-constant and HIGH = VTR time-constant	D7

Video Input Processor (VIP)

SAA7111

17 FILTER CURVES

17.1 Anti-alias filter curve

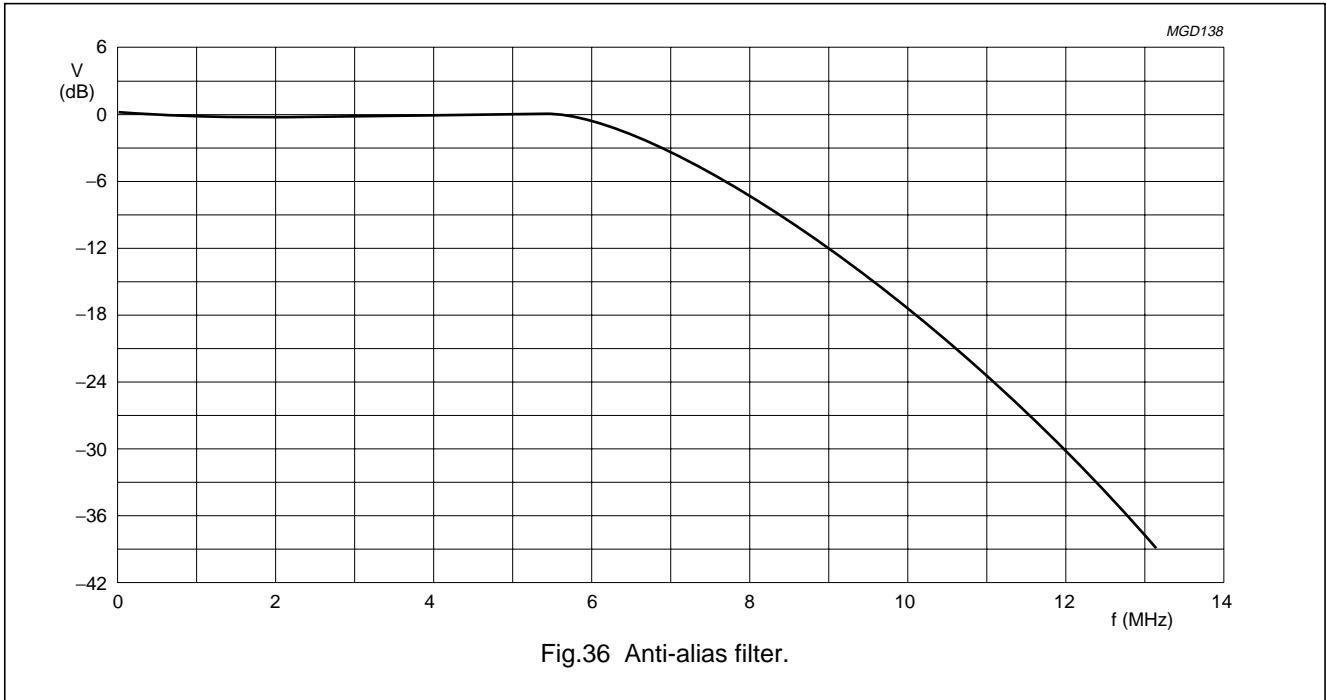

17.2 Luminance filter curves

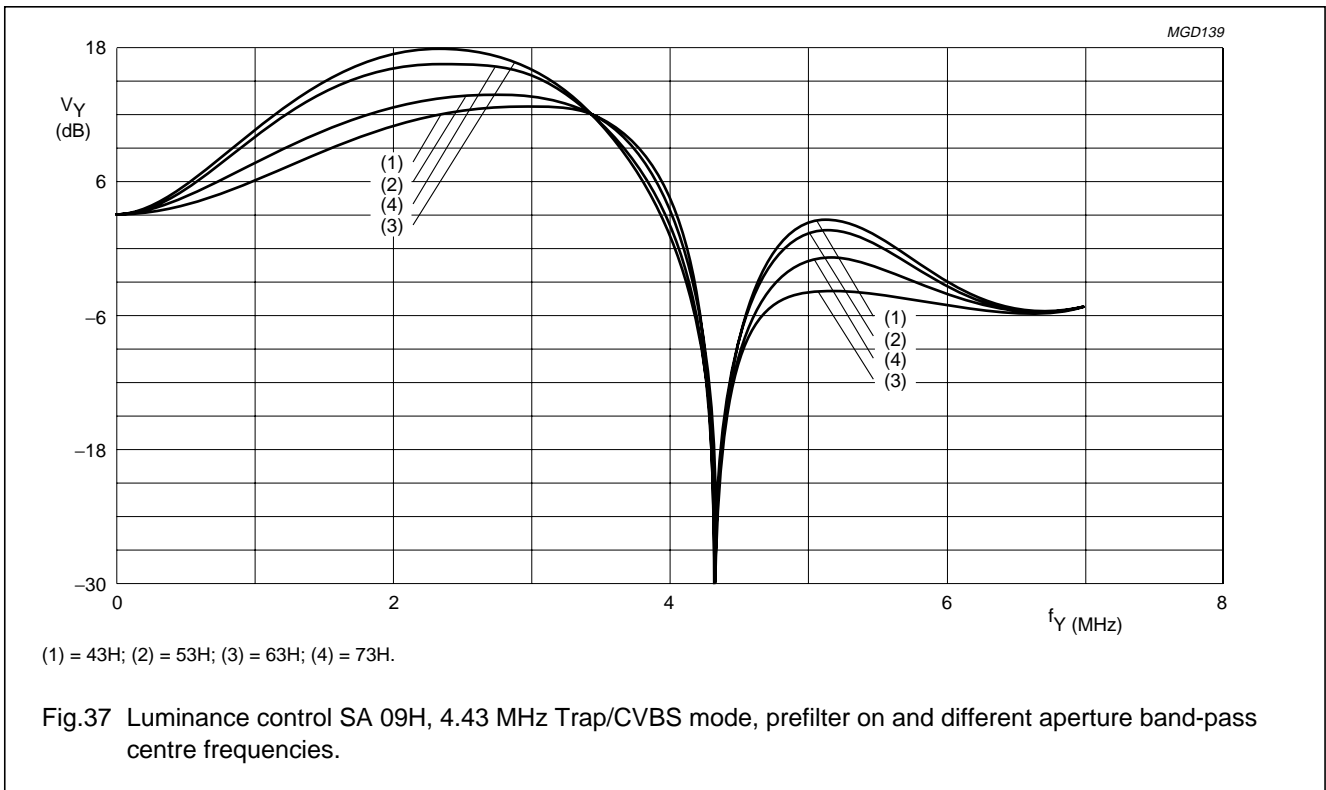

Video Input Processor (VIP)

SAA7111

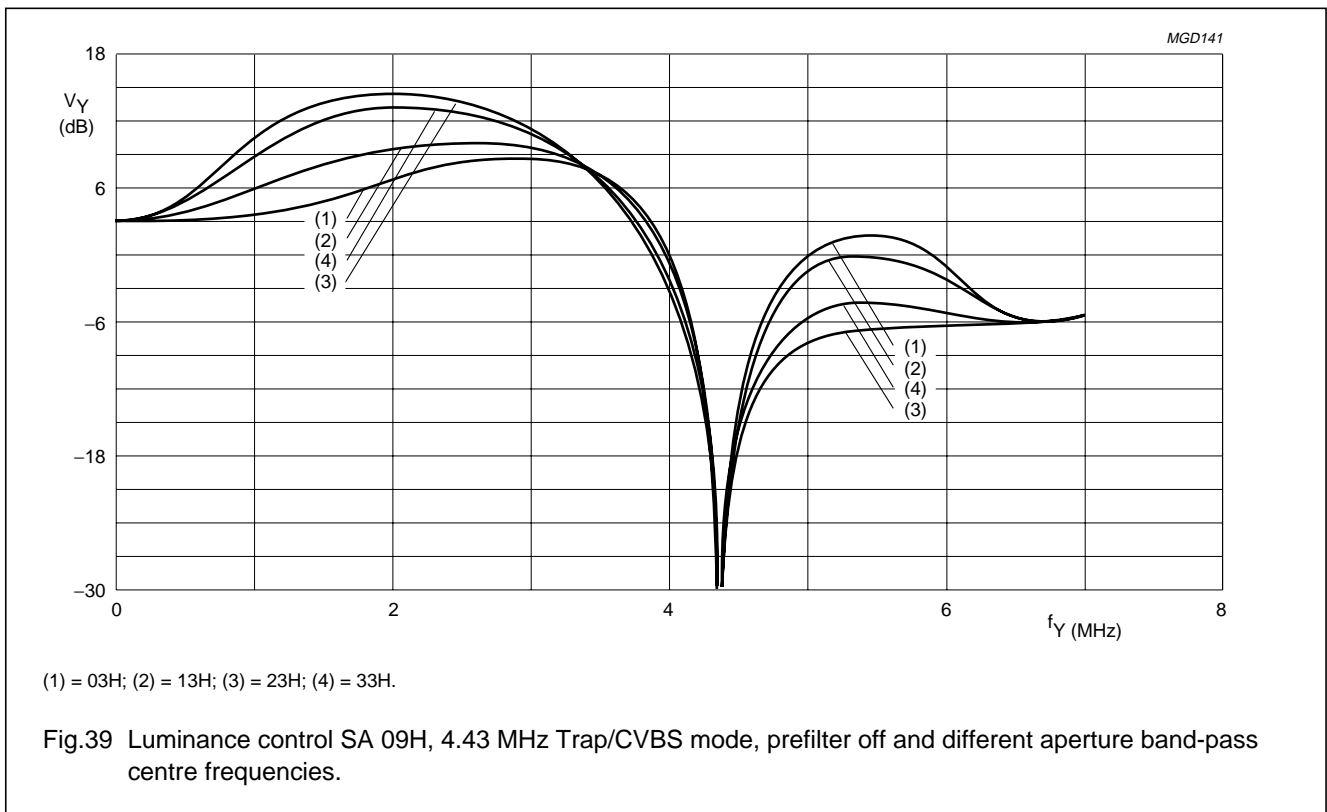
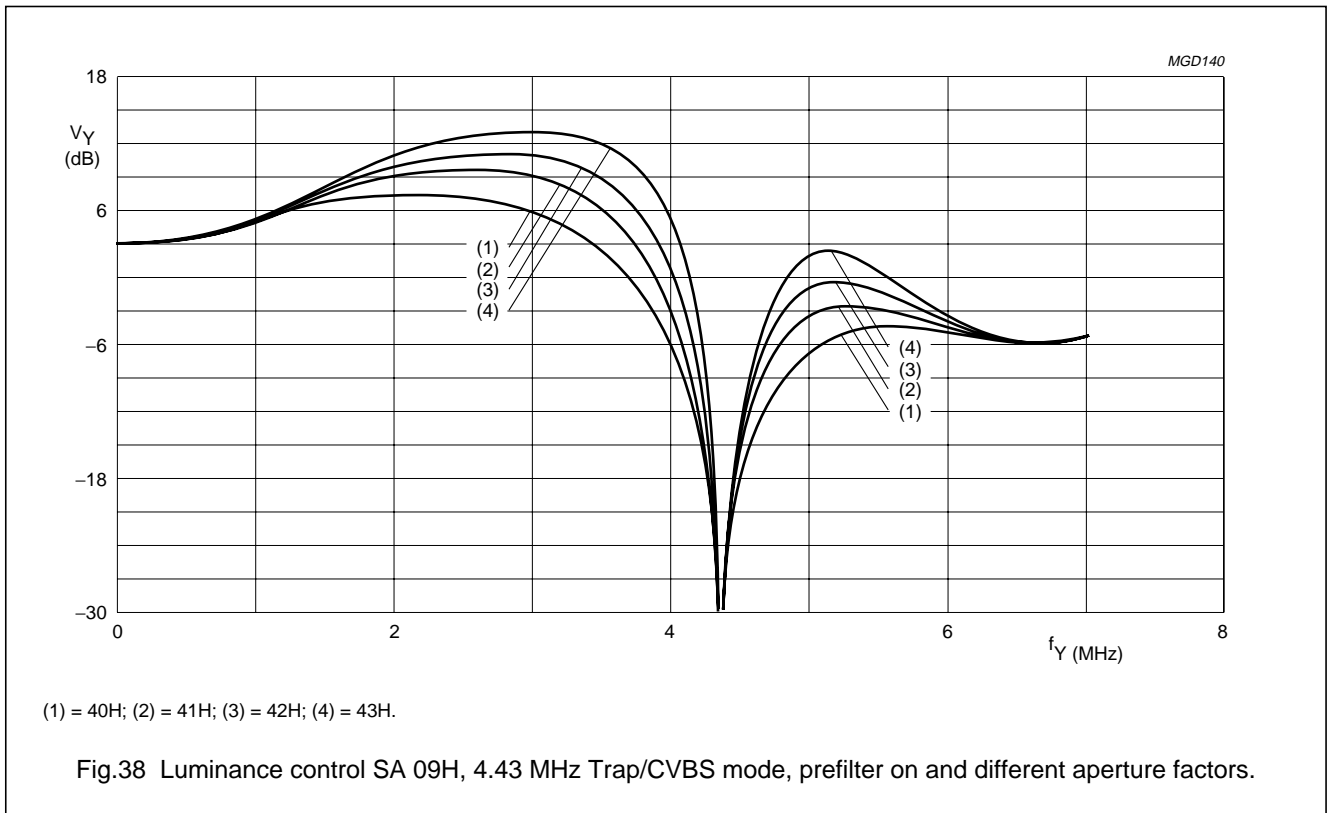

Video Input Processor (VIP)

SAA7111

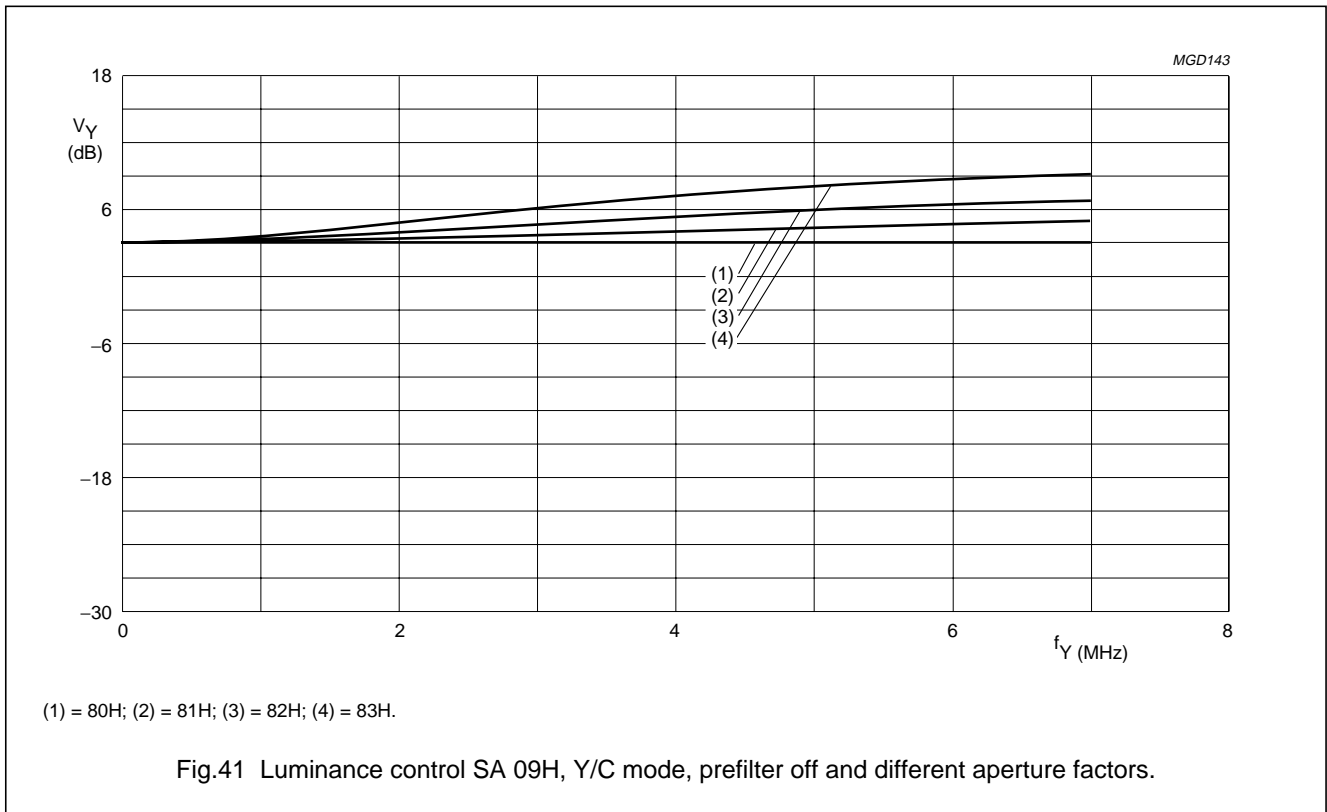
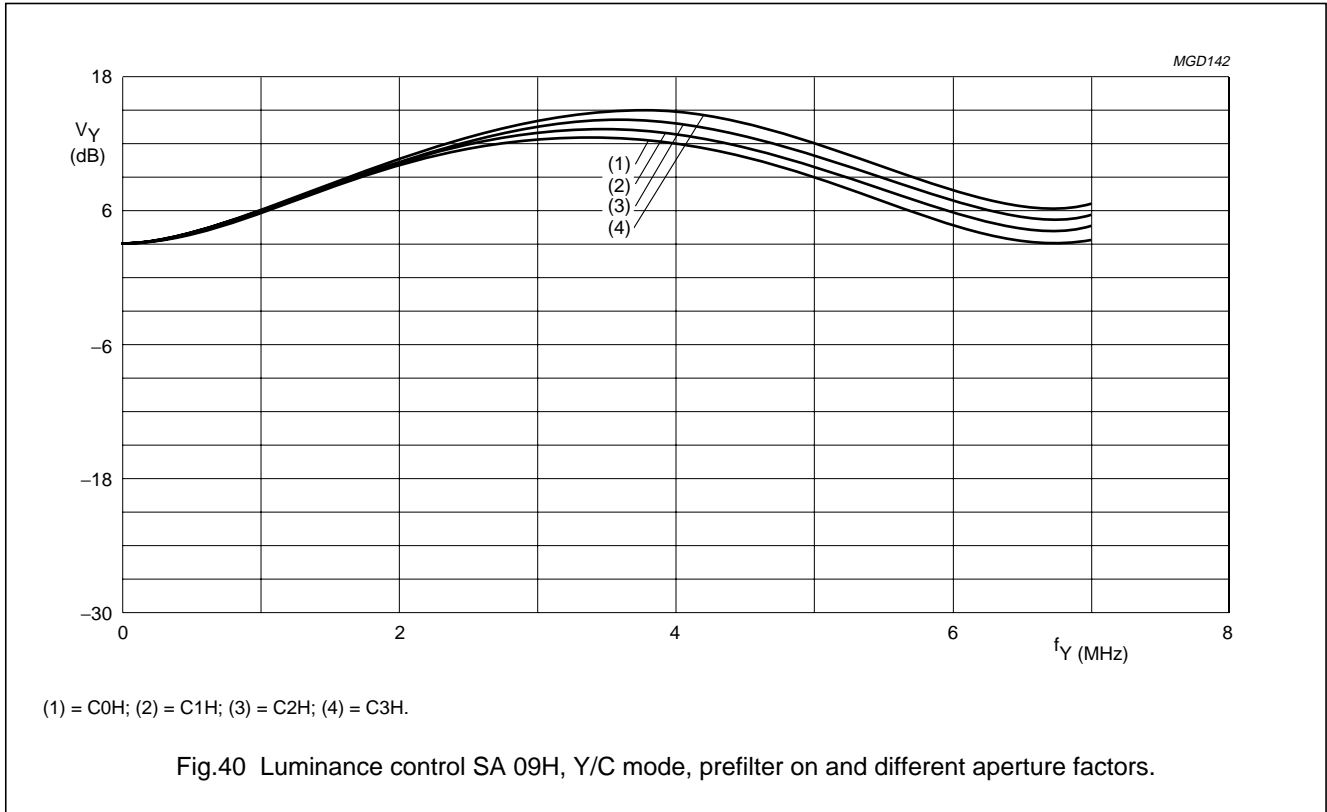

Video Input Processor (VIP)

SAA7111

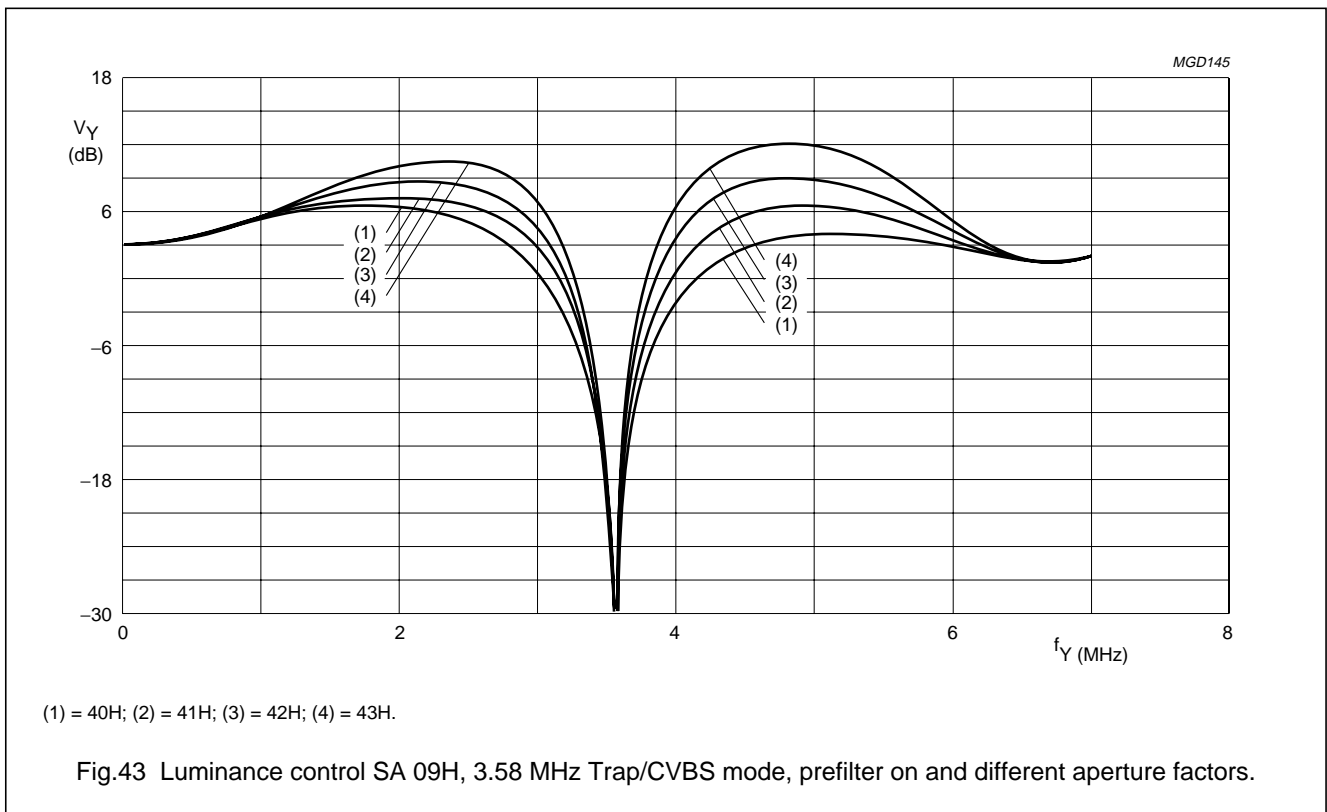
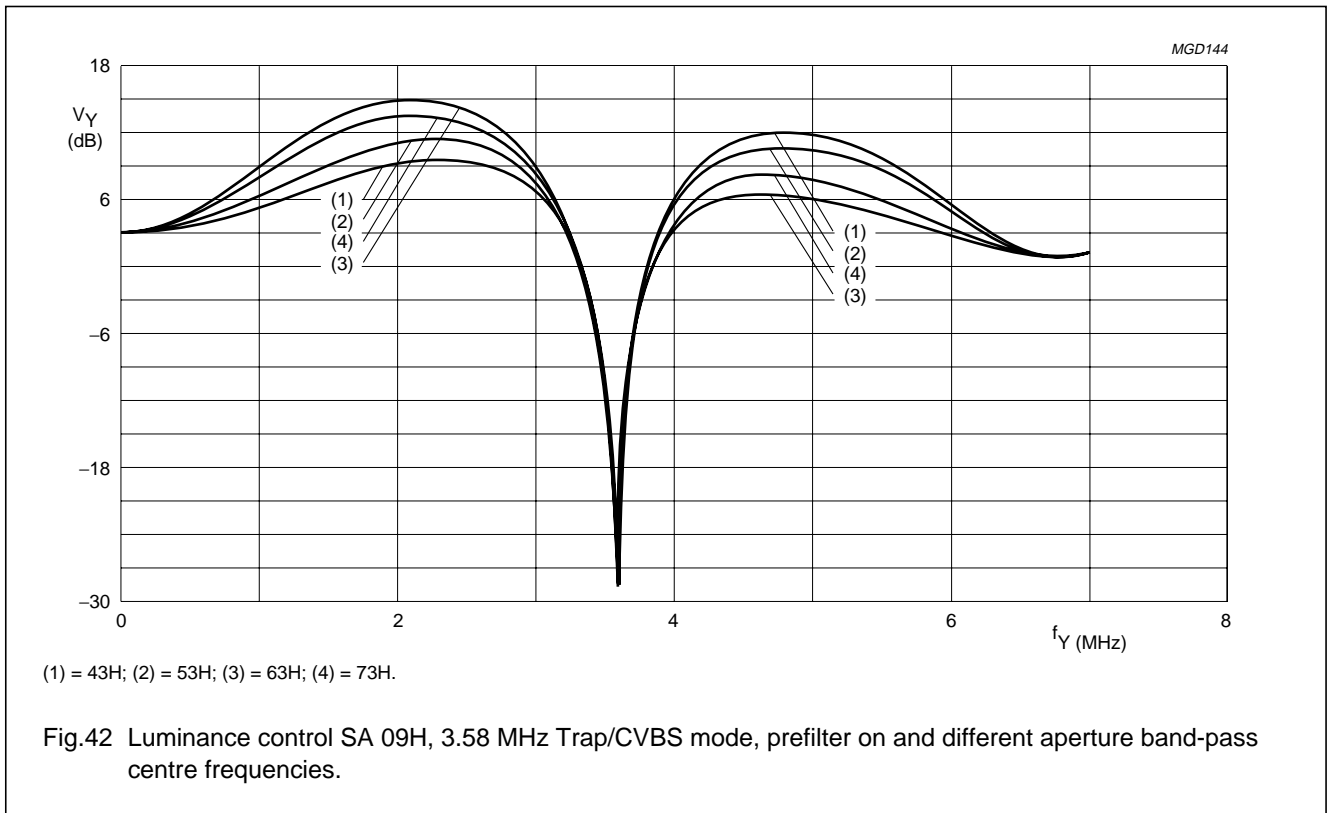

Video Input Processor (VIP)

SAA7111

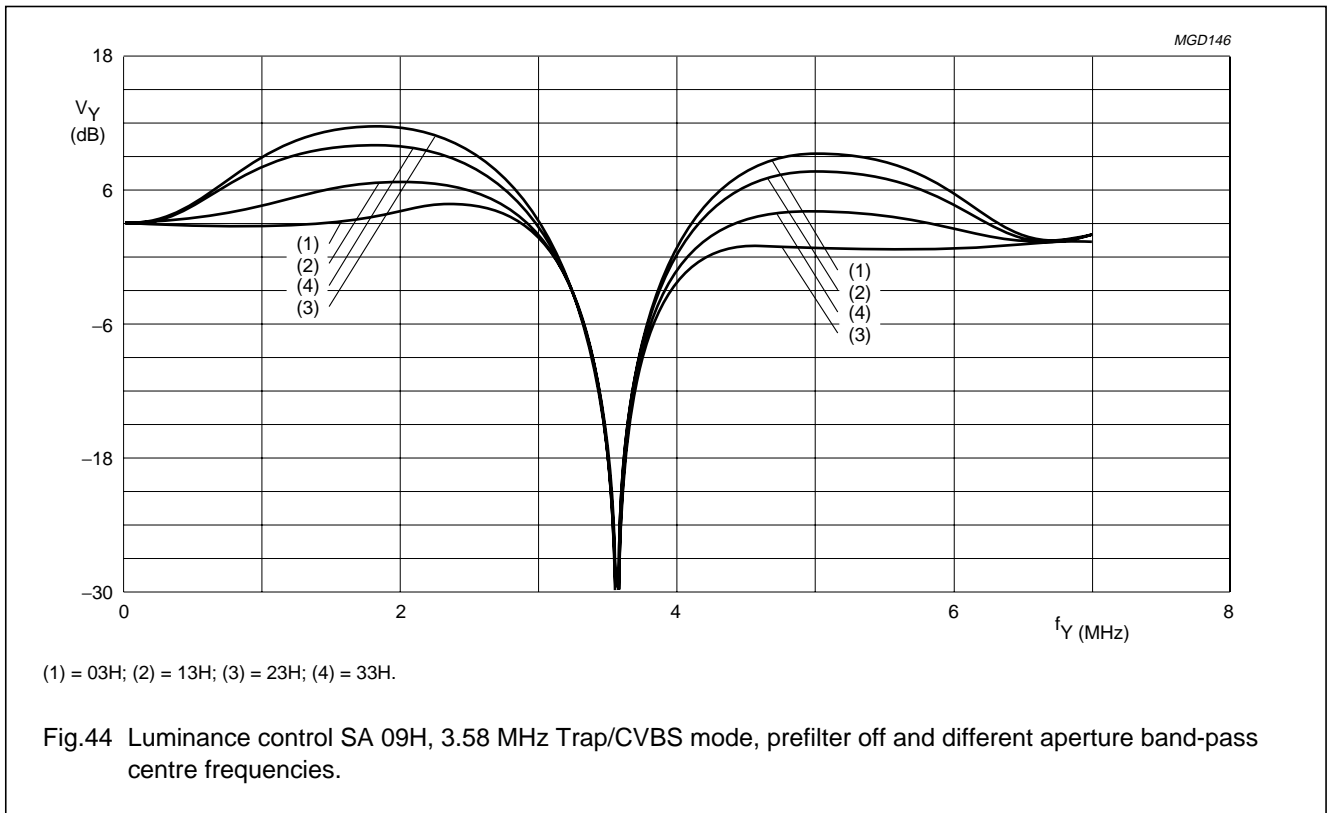

## Video Input Processor (VIP)

## SAA7111

## 17.3 Chrominance filter curves

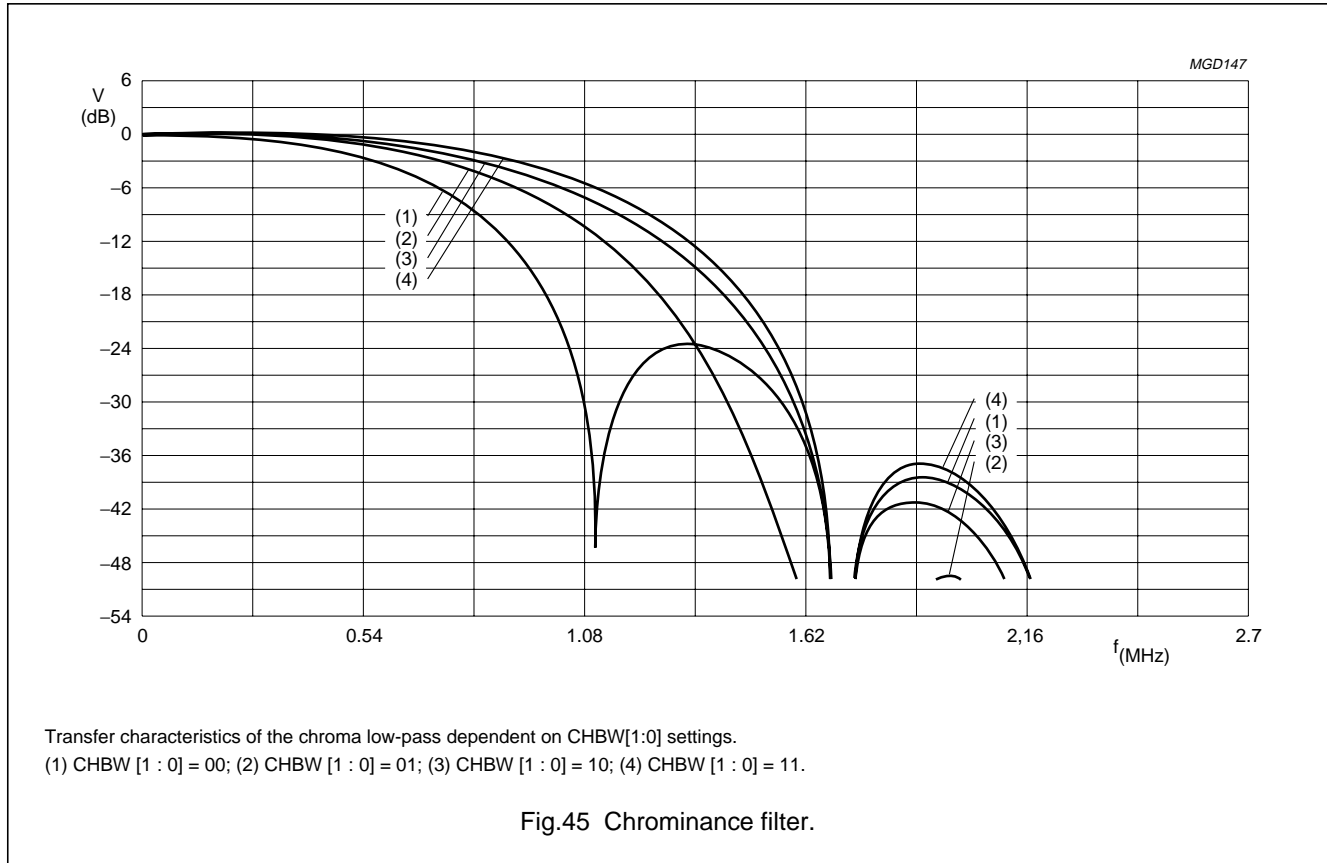
18 I<sup>2</sup>C-BUS START SET-UP

- The given values force the following behaviour of the SAA7111:
  - The analog input AI11 expects a signal in CVBS format; analog anti-alias filter active
  - Automatic field detection
  - YUV 422/16-bit output format enabled
  - Outputs HS, HREF, VREF and VS active
  - Contrast, brightness and saturation control in accordance with CCIR standards
  - Chrominance processing with nominal bandwidth (800 kHz).

## Video Input Processor (VIP)

## SAA7111

Table 36 I<sup>2</sup>C-bus start set-up values

SUB (HEX)	FUNCTION	NAME <sup>(1)</sup>	VALUES (BIN)								(HEX)	
			7	6	5	4	3	2	1	0	START	
00	chip version	ID0(7 : 0); note 2	0	0	0	0	0	0	0	0	0	00
01	reserved		0	0	0	0	0	0	0	0	0	00
02	analog input control 1	FUSE(1 : 0), GUDL(2 : 0) and MODE(2 : 0)	1	1	0	0	0	0	0	0	0	C0
03	analog input control 2	X, HLNRS, VBSL, WPOFF, HOLDG, GAFIX, GAI2 and GAI18	0	0	1	0	0	0	1	1		33
04	analog input control 3	GAI(17 : 10)	0	0	0	0	0	0	0	0	0	00
05	analog input control 4	GAI(27 : 20)	0	0	0	0	0	0	0	0	0	00
06	horizontal sync start	HSB(7 : 0)	1	1	1	0	1	0	1	1		EB
07	horizontal sync stop	HSS(7 : 0)	1	1	1	0	0	0	0	0	0	E0
08	sync control	AUFD, FSEL, EXFIL, X, VTRC and HPLL and VNOI(1 : 0)	1	0	0	0	1	0	0	0	0	88
09	luminance control	BYPS, PREF, BPSS(1 : 0), VBLB, UPTCV and APER(1 : 0)	0	0	0	0	0	0	0	1		01
0A	luminance brightness	BRIG(7 : 0)	1	0	0	0	0	0	0	0	0	80
0B	luminance contrast	CONT(7 : 0)	0	1	0	0	0	1	1	1		47
0C	chrominance saturation	SATN(7 : 0)	0	1	0	0	0	0	0	0	0	40
0D	chroma hue control	HUEC(7 : 0)	0	0	0	0	0	0	0	0	0	00
0E	chrominance control	CDTO, CM99, CSTD(1 : 0), DCCF, FCTC and CHBW(1 : 0)	0	0	0	0	0	0	0	1		01
0F	reserved		0	0	0	0	0	0	0	0	0	00
10	format/delay control	OFTS(1 : 0), HDEL(1 : 0), VRLN and YDEL(2 : 0)	0	1	0	0	0	0	0	0	0	40
11	output control 1	GPSW, X, FECO, COMPO, OEYC, OEHV, VIPB and COLO	0	0	0	1	1	1	0	0		1C
12	output control 2	RTSE(1 : 0), X, CBR, RGB888, DIT and AOSL(1 : 0)	0	0	0	0	0	0	0	1		03
13 to 19	reserved		0	0	0	0	0	0	0	0	0	00
1A	text slicer status	0, 0, 0, 0, F2VAL, F2RDY, F1VAL and F1RDY	read only register									
1B	decoded bytes of the text slicer	P1 and BYTE1(6 : 0)										
1C		P2 and BYTE2(6 : 0)										
1D to 1E	reserved		0	0	0	0	0	0	0	0	0	00
1F	status byte	STTC, HLCK, FIDT, GLIMT, GLIMB, WIPA and SLTCA and CODE	read only register									

## Notes

- All X values must be set to LOW.
- The I<sup>2</sup>C-bus subaddress 00 has to be initialized with 0 prior to reading.



Video Input Processor (VIP)

SAA7111

19 PACKAGE OUTLINES

PLCC68: plastic leaded chip carrier; 68 leads

SOT188-2

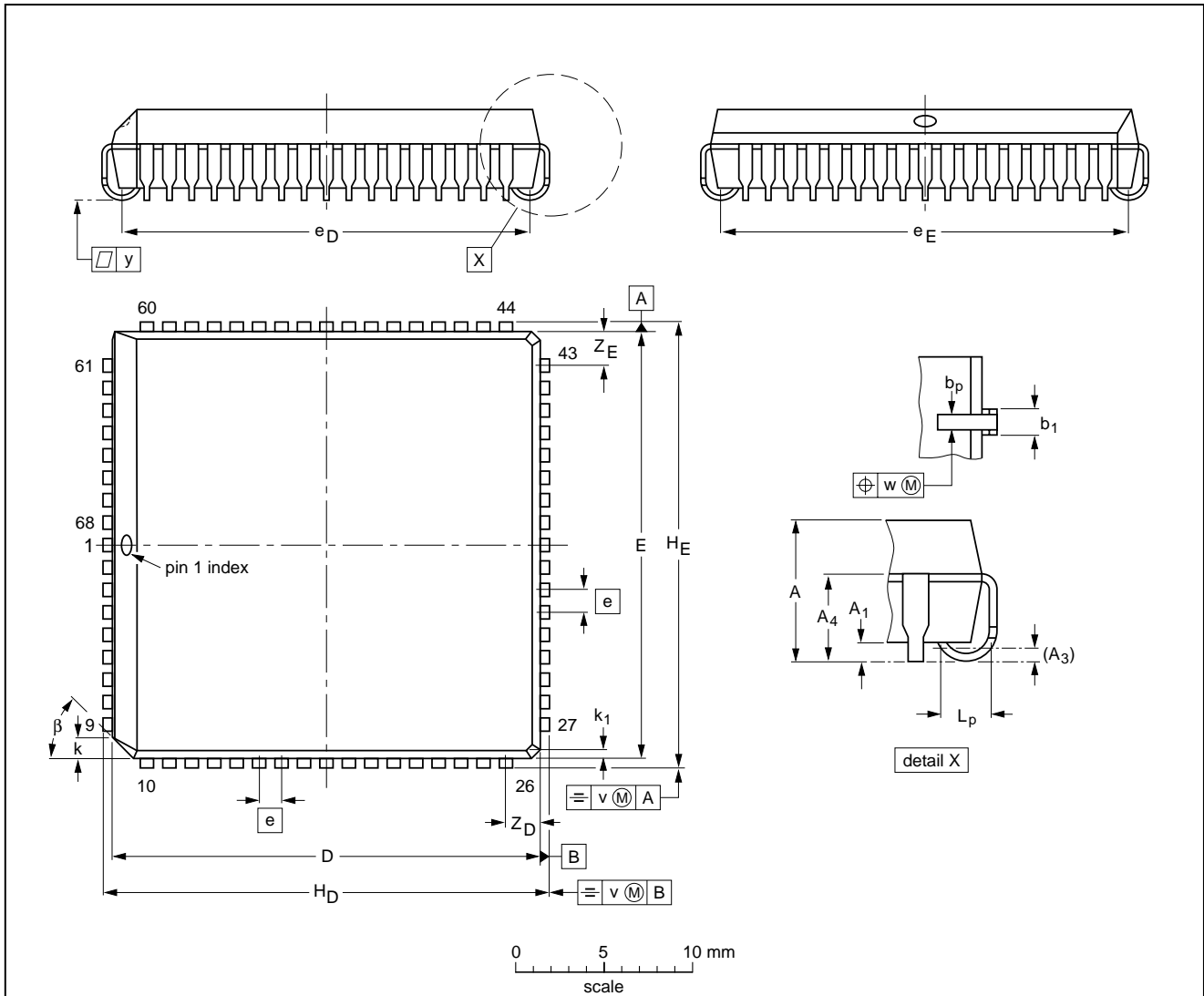

DIMENSIONS (millimetre dimensions are derived from the original inch dimensions)

UNIT	A	A <sub>1</sub> min.	A <sub>3</sub>	A <sub>4</sub> max.	b <sub>p</sub>	b <sub>1</sub>	D <sup>(1)</sup>	E <sup>(1)</sup>	e	e <sub>D</sub>	e <sub>E</sub>	H <sub>D</sub>	H <sub>E</sub>	k	k <sub>1</sub> max.	L <sub>p</sub>	v	w	y	Z <sub>D</sub> <sup>(1)</sup> max.	Z <sub>E</sub> <sup>(1)</sup> max.	$\beta$
mm	4.57 4.19	0.51	0.25	3.30	0.53 0.33	0.81 0.66	24.33 24.13	24.33 24.13	1.27	23.62 22.61	23.62 22.61	25.27 25.02	25.27 25.02	1.22 1.07	0.51	1.44 1.02	0.18	0.18	0.10	2.16	2.16	45°
inches	0.180 0.165	0.020	0.01	0.13	0.021 0.013	0.032 0.026	0.958 0.950	0.958 0.950	0.05	0.930 0.890	0.930 0.890	0.995 0.985	0.995 0.985	0.048 0.042	0.020	0.057 0.040	0.007	0.007	0.004	0.085	0.085	

Note

1. Plastic or metal protrusions of 0.01 inches maximum per side are not included.

OUTLINE VERSION	REFERENCES				EUROPEAN PROJECTION	ISSUE DATE
	IEC	JEDEC	EIAJ			
SOT188-2	112E10	MO-047AC				92-11-17 95-03-11

Video Input Processor (VIP)

SAA7111

QFP64: plastic quad flat package; 64 leads (lead length 1.6 mm); body 14 x 14 x 2.7 mm

SOT393-1

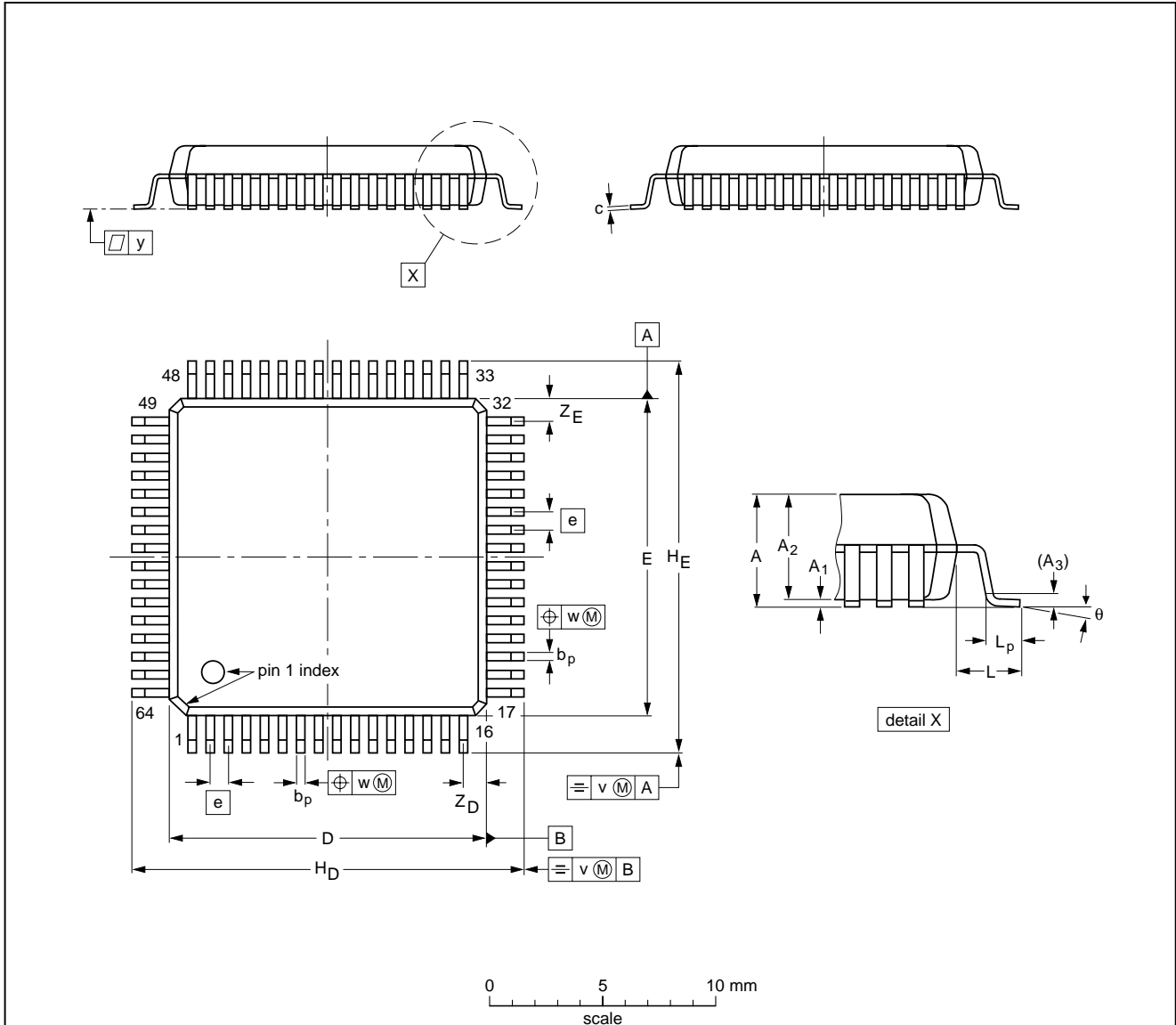

**DIMENSIONS (mm are the original dimensions)**

UNIT	A max.	A <sub>1</sub>	A <sub>2</sub>	A <sub>3</sub>	b <sub>p</sub>	c	D <sup>(1)</sup>	E <sup>(1)</sup>	e	H <sub>D</sub>	H <sub>E</sub>	L	L <sub>p</sub>	v	w	y	Z <sub>D</sub> <sup>(1)</sup>	Z <sub>E</sub> <sup>(1)</sup>	θ
mm	3.00	0.25 0.10	2.75 2.55	0.25	0.45 0.30	0.23 0.13	14.1 13.9	14.1 13.9	0.8	17.45 16.95	17.45 16.95	1.60	1.03 0.73	0.16	0.16	0.10	1.2 0.8	1.2 0.8	7° 0°

**Note**

1. Plastic or metal protrusions of 0.25 mm maximum per side are not included.

OUTLINE VERSION	REFERENCES				EUROPEAN PROJECTION	ISSUE DATE
	IEC	JEDEC	EIAJ			
SOT393-1		MS-022				96-05-21 97-08-04

## Video Input Processor (VIP)

SAA7111

### 20 SOLDERING

#### 20.1 Introduction

There is no soldering method that is ideal for all IC packages. Wave soldering is often preferred when through-hole and surface mounted components are mixed on one printed-circuit board. However, wave soldering is not always suitable for surface mounted ICs, or for printed-circuits with high population densities. In these situations reflow soldering is often used.

This text gives a very brief insight to a complex technology. A more in-depth account of soldering ICs can be found in our "IC Package Databook" (order code 9398 652 90011).

#### 20.2 Reflow soldering

Reflow soldering techniques are suitable for all PLCC and QFP packages.

The choice of heating method may be influenced by larger PLCC or QFP packages (44 leads, or more). If infrared or vapour phase heating is used and the large packages are not absolutely dry (less than 0.1% moisture content by weight), vaporization of the small amount of moisture in them can cause cracking of the plastic body. For more information, refer to the Drypack chapter in our "Quality Reference Handbook" (order code 9397 750 00192).

Reflow soldering requires solder paste (a suspension of fine solder particles, flux and binding agent) to be applied to the printed-circuit board by screen printing, stencilling or pressure-syringe dispensing before package placement.

Several methods exist for reflowing; for example, infrared/convection heating in a conveyor type oven. Throughput times (preheating, soldering and cooling) vary between 50 and 300 seconds depending on heating method. Typical reflow peak temperatures range from 215 to 250 °C.

#### 20.3 Wave soldering

##### 20.3.1 PLCC

Wave soldering techniques can be used for all PLCC packages if the following conditions are observed:

- A double-wave (a turbulent wave with high upward pressure followed by a smooth laminar wave) soldering technique should be used.
- The longitudinal axis of the package footprint must be parallel to the solder flow.
- The package footprint must incorporate solder thieves at the downstream corners.

##### 20.3.2 QFP

Wave soldering is **not** recommended for QFP packages. This is because of the likelihood of solder bridging due to closely-spaced leads and the possibility of incomplete solder penetration in multi-lead devices.

#### CAUTION

**Wave soldering is NOT applicable for all QFP packages with a pitch (e) equal or less than 0.5 mm.**

**If wave soldering cannot be avoided, for QFP packages with a pitch (e) larger than 0.5 mm, the following conditions must be observed:**

- **A double-wave (a turbulent wave with high upward pressure followed by a smooth laminar wave) soldering technique should be used.**
- **The footprint must be at an angle of 45° to the board direction and must incorporate solder thieves downstream and at the side corners.**

##### 20.3.3 METHOD (PLCC AND QFP)

During placement and before soldering, the package must be fixed with a droplet of adhesive. The adhesive can be applied by screen printing, pin transfer or syringe dispensing. The package can be soldered after the adhesive is cured.

Maximum permissible solder temperature is 260 °C, and maximum duration of package immersion in solder is 10 seconds, if cooled to less than 150 °C within 6 seconds. Typical dwell time is 4 seconds at 250 °C.

A mildly-activated flux will eliminate the need for removal of corrosive residues in most applications.

#### 20.4 Repairing soldered joints

Fix the component by first soldering two diagonally-opposite end leads. Use only a low voltage soldering iron (less than 24 V) applied to the flat part of the lead. Contact time must be limited to 10 seconds at up to 300 °C. When using a dedicated tool, all other leads can be soldered in one operation within 2 to 5 seconds between 270 and 320 °C.

## Video Input Processor (VIP)

SAA7111

**21 DEFINITIONS**

<b>Data sheet status</b>	
Objective specification	This data sheet contains target or goal specifications for product development.
Preliminary specification	This data sheet contains preliminary data; supplementary data may be published later.
Product specification	This data sheet contains final product specifications.
<b>Limiting values</b>	
Limiting values given are in accordance with the Absolute Maximum Rating System (IEC 134). Stress above one or more of the limiting values may cause permanent damage to the device. These are stress ratings only and operation of the device at these or at any other conditions above those given in the Characteristics sections of the specification is not implied. Exposure to limiting values for extended periods may affect device reliability.	
<b>Application information</b>	
Where application information is given, it is advisory and does not form part of the specification.	

**22 LIFE SUPPORT APPLICATIONS**

These products are not designed for use in life support appliances, devices, or systems where malfunction of these products can reasonably be expected to result in personal injury. Philips customers using or selling these products for use in such applications do so at their own risk and agree to fully indemnify Philips for any damages resulting from such improper use or sale.

**23 PURCHASE OF PHILIPS I<sup>2</sup>C COMPONENTS**

Purchase of Philips I<sup>2</sup>C components conveys a license under the Philips' I<sup>2</sup>C patent to use the components in the I<sup>2</sup>C system provided the system conforms to the I<sup>2</sup>C specification defined by Philips. This specification can be ordered using the code 9398 393 40011.

Video Input Processor (VIP)

SAA7111

---

**NOTES**

Video Input Processor (VIP)

SAA7111

---

**NOTES**

Video Input Processor (VIP)

SAA7111

---

**NOTES**

# Philips Semiconductors – a worldwide company

**Argentina:** see South America

**Australia:** 34 Waterloo Road, NORTH RYDE, NSW 2113, Tel. +61 2 9805 4455, Fax. +61 2 9805 4466

**Austria:** Computerstr. 6, A-1101 WIEN, P.O. Box 213, Tel. +43 160 1010, Fax. +43 160 101 1210

**Belarus:** Hotel Minsk Business Center, Bld. 3, r. 1211, Volodarski Str. 6, 220050 MINSK, Tel. +375 172 200 733, Fax. +375 172 200 773

**Belgium:** see The Netherlands

**Brazil:** see South America

**Bulgaria:** Philips Bulgaria Ltd., Energoproject, 15th floor, 51 James Bourchier Blvd., 1407 SOFIA, Tel. +359 2 689 211, Fax. +359 2 689 102

**Canada:** PHILIPS SEMICONDUCTORS/COMPONENTS, Tel. +1 800 234 7381

**China/Hong Kong:** 501 Hong Kong Industrial Technology Centre, 72 Tat Chee Avenue, Kowloon Tong, HONG KONG, Tel. +852 2319 7888, Fax. +852 2319 7700

**Colombia:** see South America

**Czech Republic:** see Austria

**Denmark:** Prags Boulevard 80, PB 1919, DK-2300 COPENHAGEN S, Tel. +45 32 88 2636, Fax. +45 31 57 0044

**Finland:** Sinikalliontie 3, FIN-02630 ESPOO, Tel. +358 9 615800, Fax. +358 9 61580920

**France:** 51 Rue Carnot, BP317, 92156 SURESNES Cedex, Tel. +33 1 40 99 6161, Fax. +33 1 40 99 6427

**Germany:** Hammerbrookstraße 69, D-20097 HAMBURG, Tel. +49 40 23 53 60, Fax. +49 40 23 536 300

**Greece:** No. 15, 25th March Street, GR 17778 TAVROS/ATHENS, Tel. +30 1 4894 339/239, Fax. +30 1 4814 240

**Hungary:** see Austria

**India:** Philips INDIA Ltd, Band Box Building, 2nd floor, 254-D, Dr. Annie Besant Road, Worli, MUMBAI 400 025, Tel. +91 22 493 8541, Fax. +91 22 493 0966

**Indonesia:** PT Philips Development Corporation, Semiconductors Division, Gedung Philips, Jl. Buncit Raya Kav.99-100, JAKARTA 12510, Tel. +62 21 794 0040 ext. 2501, Fax. +62 21 794 0080

**Ireland:** Newstead, Clonskeagh, DUBLIN 14, Tel. +353 1 7640 000, Fax. +353 1 7640 200

**Israel:** RAPAC Electronics, 7 Kehilat Saloniki St, PO Box 18053, TEL AVIV 61180, Tel. +972 3 645 0444, Fax. +972 3 649 1007

**Italy:** PHILIPS SEMICONDUCTORS, Piazza IV Novembre 3, 20124 MILANO, Tel. +39 2 6752 2531, Fax. +39 2 6752 2557

**Japan:** Philips Bldg 13-37, Kohnan 2-chome, Minato-ku, TOKYO 108-8507, Tel. +81 3 3740 5130, Fax. +81 3 3740 5077

**Korea:** Philips House, 260-199 Itaewon-dong, Yongsan-ku, SEOUL, Tel. +82 2 709 1412, Fax. +82 2 709 1415

**Malaysia:** No. 76 Jalan Universiti, 46200 PETALING JAYA, SELANGOR, Tel. +60 3 750 5214, Fax. +60 3 757 4880

**Mexico:** 5900 Gateway East, Suite 200, EL PASO, TEXAS 79905, Tel. +9-5 800 234 7381

**Middle East:** see Italy

**Netherlands:** Postbus 90050, 5600 PB EINDHOVEN, Bldg. VB, Tel. +31 40 27 82785, Fax. +31 40 27 88399

**New Zealand:** 2 Wagener Place, C.P.O. Box 1041, AUCKLAND, Tel. +64 9 849 4160, Fax. +64 9 849 7811

**Norway:** Box 1, Manglerud 0612, OSLO, Tel. +47 22 74 8000, Fax. +47 22 74 8341

**Pakistan:** see Singapore

**Philippines:** Philips Semiconductors Philippines Inc., 106 Valero St. Salcedo Village, P.O. Box 2108 MCC, MAKATI, Metro MANILA, Tel. +63 2 816 6380, Fax. +63 2 817 3474

**Poland:** Ul. Lukiska 10, PL 04-123 WARSZAWA, Tel. +48 22 612 2831, Fax. +48 22 612 2327

**Portugal:** see Spain

**Romania:** see Italy

**Russia:** Philips Russia, Ul. Usatcheva 35A, 119048 MOSCOW, Tel. +7 095 755 6918, Fax. +7 095 755 6919

**Singapore:** Lorong 1, Toa Payoh, SINGAPORE 319762, Tel. +65 350 2538, Fax. +65 251 6500

**Slovakia:** see Austria

**Slovenia:** see Italy

**South Africa:** S.A. PHILIPS Pty Ltd., 195-215 Main Road Martindale, 2092 JOHANNESBURG, P.O. Box 7430 Johannesburg 2000, Tel. +27 11 470 5911, Fax. +27 11 470 5494

**South America:** Al. Vicente Pinzon, 173, 6th floor, 04547-130 SÃO PAULO, SP, Brazil, Tel. +55 11 821 2333, Fax. +55 11 821 2382

**Spain:** Balmes 22, 08007 BARCELONA, Tel. +34 93 301 6312, Fax. +34 93 301 4107

**Sweden:** Kottbygatan 7, Akalla, S-16485 STOCKHOLM, Tel. +46 8 5985 2000, Fax. +46 8 5985 2745

**Switzerland:** Allmendstrasse 140, CH-8027 ZÜRICH, Tel. +41 1 488 2741 Fax. +41 1 488 3263

**Taiwan:** Philips Semiconductors, 6F, No. 96, Chien Kuo N. Rd., Sec. 1, TAIPEI, Taiwan Tel. +886 2 2134 2865, Fax. +886 2 2134 2874

**Thailand:** PHILIPS ELECTRONICS (THAILAND) Ltd., 209/2 Sanpavuth-Bangna Road Prakanong, BANGKOK 10260, Tel. +66 2 745 4090, Fax. +66 2 398 0793

**Turkey:** Talatpasa Cad. No. 5, 80640 GÜLTEPE/ISTANBUL, Tel. +90 212 279 2770, Fax. +90 212 282 6707

**Ukraine:** PHILIPS UKRAINE, 4 Patrice Lumumba str., Building B, Floor 7, 252042 KIEV, Tel. +380 44 264 2776, Fax. +380 44 268 0461

**United Kingdom:** Philips Semiconductors Ltd., 276 Bath Road, Hayes, MIDDLESEX UB3 5BX, Tel. +44 181 730 5000, Fax. +44 181 754 8421

**United States:** 811 East Arques Avenue, SUNNYVALE, CA 94088-3409, Tel. +1 800 234 7381

**Uruguay:** see South America

**Vietnam:** see Singapore

**Yugoslavia:** PHILIPS, Trg N. Pasica 5/v, 11000 BEOGRAD, Tel. +381 11 625 344, Fax. +381 11 635 777

**For all other countries apply to:** Philips Semiconductors, International Marketing & Sales Communications, Building BE-p, P.O. Box 218, 5600 MD EINDHOVEN, The Netherlands, Fax. +31 40 27 24825

**Internet:** <http://www.semiconductors.philips.com>

© Philips Electronics N.V. 1998

SCA60

All rights are reserved. Reproduction in whole or in part is prohibited without the prior written consent of the copyright owner.

The information presented in this document does not form part of any quotation or contract, is believed to be accurate and reliable and may be changed without notice. No liability will be accepted by the publisher for any consequence of its use. Publication thereof does not convey nor imply any license under patent- or other industrial or intellectual property rights.

Printed in The Netherlands

655102/1200/03/pp64

Date of release: 1998 May 15

Document order number: 9397 750 03116

*Let's make things better.*

**Philips  
Semiconductors**



**PHILIPS**



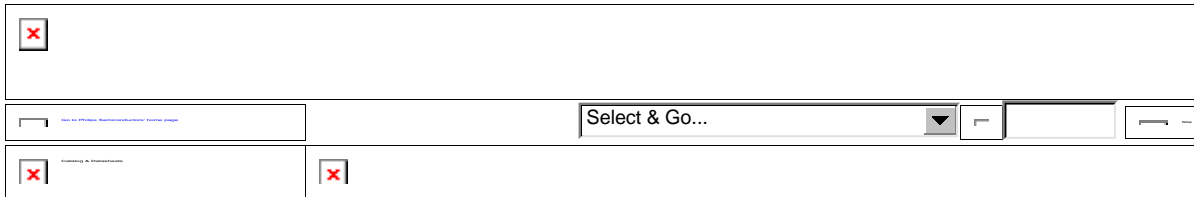

Information as of 2000-08-24

- Catalog by Function
- Discrete semiconductors
  - Audio
  - Clocks and Watches
  - Data communications
  - Microcontrollers
  - Peripherals
  - Standard analog
  - Video
  - Wired communications
  - Wireless communications

## SAA7111; Video Input Processor (VIP)

- [Description](#)
- [Features](#)
- [Applications](#)
- [Datasheet](#)
- [Products, packages, availability and ordering](#)
- [Find similar products](#)

- Catalog by System
- Automotive
  - Consumer Multimedia Systems
  - Communications
  - PC/PC-peripherals

Cross reference

Models

Packages

Application notes

Selection guides

Other technical documentation

End of Life information

Datahandbook system

Relevant Links

- About catalog tree
- About search
- About this site
- Subscribe to eNews
- Catalog & Datasheets
- Search
- [SAA7111](#)
- [SAA7111](#)

## Description

The Video Input Processor (VIP) is a combination of a two-channel analog preprocessing circuit including source selection, anti-aliasing filter and ADC, an automatic clamp and gain control, a Clock Generation Circuit (CGC), a digital multi-standard decoder (PAL BGHI, PAL M, PAL N, NTSC M and NTSC N), a brightness/contrast/saturation control circuit and a colour space matrix (see Fig.1). The CMOS circuit SAA7111, analog front-end and digital video decoder, is a highly integrated circuit for desktop video applications. The decoder is based on the principle of line-locked clock decoding and is able to decode the colour of PAL and NTSC signals into CCIR-601 compatible colour component values. The SAA7111 accepts as analog inputs CVBS or S-video (Y/C) from TV or VTR sources. The circuit is I<sub>2</sub>C-bus controlled.

## Features

- Four analog inputs/internal analog source selectorse.g. 4 ´ CVBS or 2 ´ Y/C or (1 ´ Y/C and 2 ´ CVBS)
- Two analog preprocessing channels
- Fully programmable static gain for the main channels or automatic gain control for the selected CVBS or Y/C channel
- Switchable white peak control
- Two built-in analog anti-aliasing filters
- Two 8-bit video CMOS analog-to-digital converters (ADCs)
- On-chip clock generator
- Line-locked system clock frequencies
- Digital PLL for H-sync processing and clock generation
- Requires only one crystal (24.576 MHz) for all standards
- Horizontal and vertical sync detection
- Automatic detection of 50/60 Hz field frequency and automatic switching between standards PAL and NTSC
- Luminance and chrominance signal processing for PAL BGHI, PAL N, PAL M, NTSC MNTSC N and NTSC 4.43
- User programmable luminance peaking or aperture correction



To be kept informed on SAA7111, subscribe to eNews.

- Cross-colour reduction for NTSC by chrominance comb filtering
- PAL delay line for correcting PAL phase errors
- Real time status information output (RTCO)
- Brightness Contrast Saturation (BCS) control on-chip
- The YUV (CCIR-601) bus supports a data rate of:
  - 864  $\times$   $f_H$  = 13.5 MHz for 625 line sources
  - 858  $\times$   $f_H$  = 13.5 MHz for 525 line sources.
- Data output streams for 1612 or 8-bit width with the following formats:
  - 411 YUV (12-bit)
  - 422 YUV (16-bit)
  - 422 YUV [CCIR-656] (8-bit)
  - 565 RGB (16-bit) with dither
  - 888 RGB (24-bit) with special application.
- 720 active samples per line on the YUV bus
- One user programmable general purpose switch on an output pin
- Built in line-21 text slicer
- Power-on control
- Two switchable outputs for the digitized CVBS or Y/C input signals AD1 (7 to 0) and AD2 (7 to 0) via the I<sub>2</sub>PC-bus
- Chip enable function (reset for the clock generator)
- Compatible with memory-based features (line-locked clock)
- Boundary scan test circuit complies with the IEEE Std. 1149.1- 1990 (ID-Code = 0 7111 02 B)
- I<sub>2</sub>PC-bus controlled (full read-back ability by an external controller).

## Applications



- Desktop video
- Multimedia
- Digital television
- Image processing
- Video phone.

## Datasheet



Type nr.	Title	Publication release date	Datasheet status	Page count	File size (kB)	Datasheet
SAA7111	Video Input Processor (VIP)	15-May-98	Product Specification	64	403	<input type="checkbox"/> <a href="#">Download</a>

## Products, packages, availability and ordering



<u>Partnumber</u>	<u>North American Partnumber</u>	<u>Order code (12nc)</u>	<u>marking/packing</u>	<u>package</u>	<u>device status</u>	<u>buy online</u>
SAA7111H/01	SAA7111HBG-S	9352 119 70551	Standard Marking * Tray Dry Pack, Bakeable, Single	<a href="#">SOT393</a>	Full production	<input type="checkbox"/>
	SAA7111HBG	9352 119 70557	Standard Marking * Tray Dry Pack, Bakeable, Multiple	<a href="#">SOT393</a>	Full production	<input type="checkbox"/>
SAA7111WP/01	SAA7111WPA	9352 062 10512	Standard Marking * Tube Dry Pack	<a href="#">SOT188</a>	Full production	<input type="checkbox"/>
	SAA7111WPA-T	9352 062 10518	Standard Marking * Reel Dry Pack, SMD, 13"	<a href="#">SOT188</a>	Full production	<input type="checkbox"/>

**Find similar products:**



[SAA7111](#) links to the similar products page containing an overview of products that are similar in function or related to the part number(s) as listed on this page. The similar products page includes products from the same catalog tree(s) , relevant selection guides and products from the same functional category.