

DIAMOND

Fiber Optic Components

The E-2000™ PS System is designed for high power applications up to 2 Watt optical power. The E-2000™ PS connector has been developed to support the continuous raise of higher bitrates and longer transmission distances, within DWDM technology, and is based on expanded beam technology.

A section of graded index fiber is introduced as a collimating lens, which enlarges the beam diameter and reduces power density at the connector interface.

All of the features, users have come to expect from the E-2000 family, are available from the E-2000™ PS, including: ease of installation, integrated protection caps, color coding, mechanical keying and excellent vibration resistance.

Highlights

- Injection molded housing (UL 94 V0 flammability rating)
- Spring-loaded shutters on mating adapters
- Integrated black metal protective caps
- Interchangeable color-coded and mechanically keyed thumb-latches and frames
- High modular connector-system

• Benefits

- Connector housing totally encloses ferrule to optimally protect it from dust, contaminants and scratches.
- Engage automatically to protect personnel from eye-damaging laser radiation.
- Angled, anti-reflection surface ensures low reflectance in unmated state.
- Maximizes operator eye safety protection from damaging laser radiation.
- Close automatically upon extraction to protect ferrule from dust and scratches.
- Permit clear and unmistakable identification of lines on crowded patch panels.
- Guard against improper connections.
- Single channel components can be upgraded to duplex through the use of a simple clip-bridge and an extended thumb-latch.

Specifications:

STANDARD	Single mode 4° APC	Units	Test conditions
Insertion loss (IL)	typ. 0.2 max. 0.6	dB	IEC 61300; Random
Insertion loss (IL)	typ. 0.2 max. 0.4	dB	IEC 61300; Against reference
Repeatability of IL	max. ±0.1	dB	Over service life
ΔIL vs. wavelength	max. ±0.15	dB	IEC 61300; λ = from 1300 to 1625 nm
Return loss (RL)	min. 75*	dB	IEC 61300
Service life	1000 mate/demate cycles		
Operating temperature	-40 / +85	°C	May be further limited by cable specifications
Storage temperature	-40 / +90	°C	

* Measured with high resolution reflectometer HP 8504A

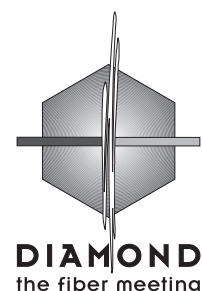

DIAMOND SA
Via dei Patrizi 5
CH-6616 LOSONE
Tel. ++41-91/785 45 45
Fax ++41-91/785 45 00
e-mail: info@diamond-fo.com

E-2000™ PS

E-2104.6 PS

E-2144.6 PS

POWER SOLUTION

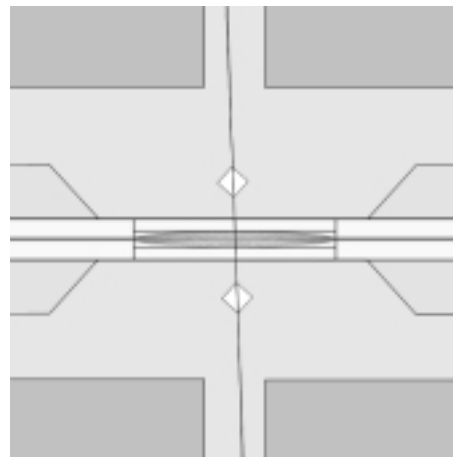

Safety information for E-2000™ Power Solution

The E-2000™ Power Solution (PS) connector takes advantage of the expanded beam technology to reduce the density of the optical power at the interface of the connection. This way the connector results to be less sensitive to contaminations, and the bearable maximum power that can be transmitted without consequences is greater.

Cleaning

Cleanliness still remains the key word using high power. The basic concept using PS connectors is therefore the following: " before each mating procedure, the connectors must be absolutely clean and inspected with a microscope ". The ferrules surface inspection should be operated using an optical microscope with a magnification of at least 200x. The connector is normally affected by contaminations during handling and mating procedures; the degree of cleanliness of the overall installation is also critical parameter to be taken into consideration.

Handling

The E-2000™ Power Solution connectors should be operated with high power only when connected. When unmated, the light source must absolutely be switched off.

Safety

Using standard as well as high power PS connectors with optical power of tens or hundreds of mW, the knowledge and respect of the safety standards is essential.

A laser source emitting 1 Watt at 1550 nm in a SM fiber is for instance recorded as a class 3B (IEC 825-1 and 825-2 standards), while the same laser with a collimated output will be classified as a class 4.

The main safety precautions that have to be considered working with class 4 lasers are summarized as follows:

- usage in restricted area, access only for authorized and qualified personnel ;
- use protective glasses, skin protective measures recommended;
- optical behavior under control: eliminate reflections (also diffuse), close unused optical channels, avoid light beams on eye level;
- switch on/off system with remote control or interlock and additional automatic switch off safety system;
- warning signal when sources are active;
- laser classification markings and danger indications.

Specifications subject to change
without notice

002-037-210P010111

Order Numbers:

E-2000™ PS

Type designation: E-2104.6
 Ferrule style: Zirconia/copper-nickel alloy insert (Pilzferrule)
 External parts: Plastic red
 Polish geometry: Convex (APC 4°)

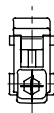
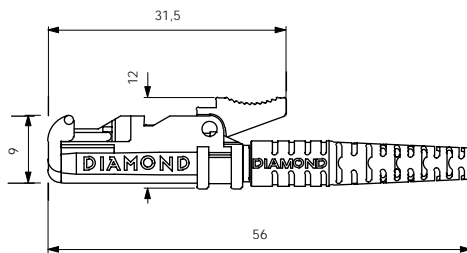

Dimensions Fiber/Cable	Order Number	
	Unterminated connector	Terminated assembly
9/125/900	33A - 000 - 001 L 000	33A - xxx - 001 L xxx
9/125/900/2100	33A - 000 - 002 L 000	33A - xxx - 002 L xxx
9/125/900/2500	33A - 000 - 003 L 000	33A - xxx - 003 L xxx
9/125/900/3000	33A - 000 - 004 L 000	33A - xxx - 004 L xxx
9/125/900/3500	33A - 000 - 005 L 000	33A - xxx - 005 L xxx

COLOR CODING

Thumb-latch	blue	green	black	red	orange	yellow	white	violet
Order No.	30A	31A	32A	33A	34A	35A	36A	37A

MECHANICAL KEYING

Thumb-latch No.	1 (red)	2 (brown)	3 (yellow)	4 (orange)	5 (violet)	6 (white)	---	---
Order No.	40A	41A	42A	43A	44A	45A	---	---

Connectors for other fiber and cable dimensions available upon request.

ADAPTER

Type designation: E-2201.2 PS
 Mating sleeve: Zirconia
 External parts: Plastic red

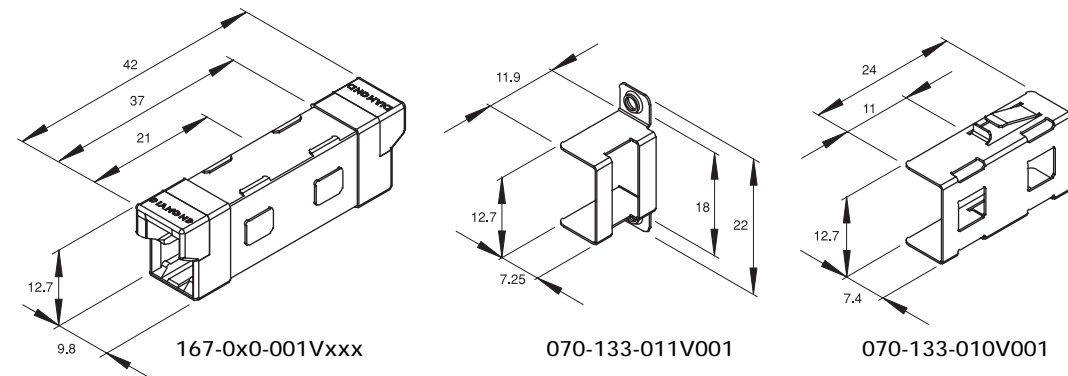

COLOR CODING

Frame color	Order Number	Frame color	Order Number
Blue	167 - 00x - 001 V 501	Orange	167 - 00x - 001 V 505
Green	167 - 00x - 001 V 502	Yellow	167 - 00x - 001 V 506
Black	167 - 00x - 001 V 503	White	167 - 00x - 001 V 507
Red	167 - 00x - 001 V 504	Violet	167 - 00x - 001 V 508

MECHANICAL KEYING

Frame No.	Order Number	Frame No.	Order Number
1 (Red)	167 - 00x - 101 V 500	4 (Orange)	167 - 00x - 401 V 500
2 (Brown)	167 - 00x - 201 V 500	5 (Violet)	167 - 00x - 501 V 500
3 (Yellow)	167 - 00x - 301 V 500	6 (White)	167 - 00x - 601 V 500

CUTOUT DIMENSIONS

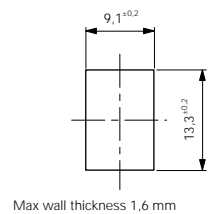
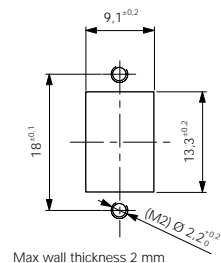

Order Number Codes

- ¹ Connector code
- ² Connector code for termination on other end of assembly:
 - For pigtails insert 000
 - For patch assemblies insert connector code for other connector
- ³ Code for fiber or cable
- ⁴ Length in meters

E-2000™ PS COMPACT (Available upon request)

Type designation: E-2144.6 PS Compact
 Ferrule material: Zirconia/copper-nickel alloy insert (Pilzferrule)
 External parts: Plastic red
 Polish geometry: Convex (APC 4°)

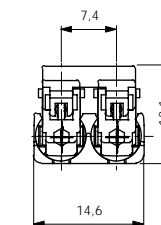
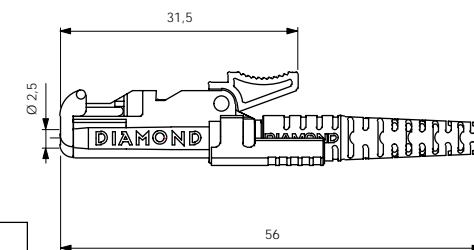

Dimensions Fiber/Cable	Order Number	
	Unterminated connector	Terminated assembly
9/125/900	33B - 000 - 001 L 000	33B - xxx - 001 L xxx
9/125/900/2100	33B - 000 - 002 L 000	33B - xxx - 002 L xxx
9/125/900/2500	33B - 000 - 003 L 000	33B - xxx - 003 L xxx
9/125/900/3000	33B - 000 - 004 L 000	33B - xxx - 004 L xxx
9/125/900/3500	33B - 000 - 005 L 000	33B - xxx - 005 L xxx

COLOR CODING

Thumb-latch	blue	green	black	red	orange	yellow	white	violet
Order No.	30B	31B	32B	33B	34B	35B	36B	37B

MECHANICAL KEYING

Thumb-latch No.	1 (red)	2 (brown)	3 (yellow)	4 (orange)	5 (violet)	6 (white)	---	---
Order No.	40B	41B	42B	43B	44B	45B	---	---

Connectors for other fiber and cable dimensions available upon request.

ADAPTER

Type designation: E-2210.2 PS Compact
 Mating sleeve: Zirconia
 External parts: Plastic Red

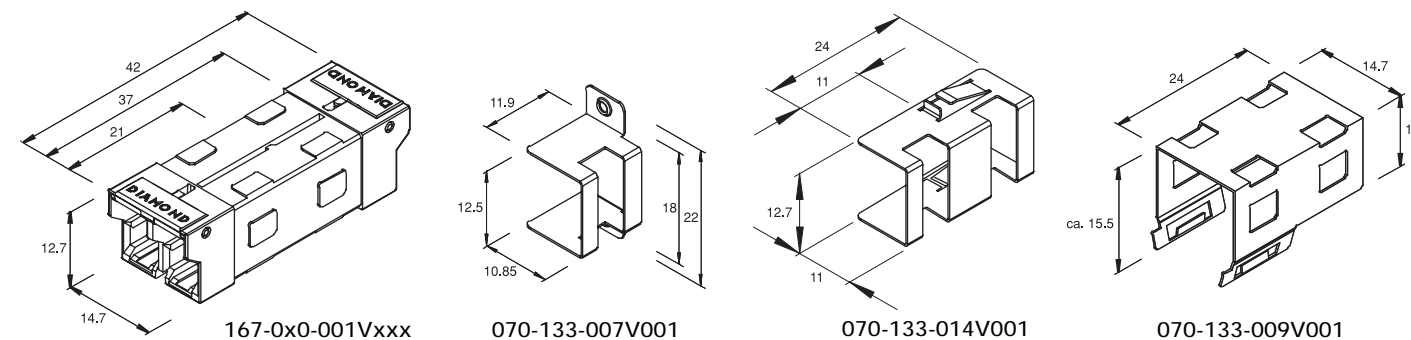

COLOR CODING

Frame color	Order Number	Frame color	Order Number
Blue	167 - 03x - 001 V 501	Orange	167 - 03x - 001 V 505
Green	167 - 03x - 001 V 502	Yellow	167 - 03x - 001 V 506
Black	167 - 03x - 001 V 503	White	167 - 03x - 001 V 507
Red	167 - 03x - 001 V 504	Violet	167 - 03x - 001 V 508

MECHANICAL KEYING

Frame No.	Order Number	Frame No.	Order Number
1 (Red)	167 - 03x - 101 V 500	4 (Orange)	167 - 03x - 401 V 500
2 (Brown)	167 - 03x - 201 V 500	5 (Violet)	167 - 03x - 501 V 500
3 (Yellow)	167 - 03x - 301 V 500	6 (White)	167 - 03x - 601 V 500

CUTOUT DIMENSIONS

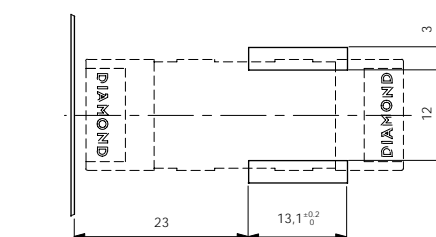
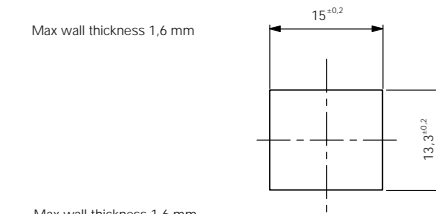
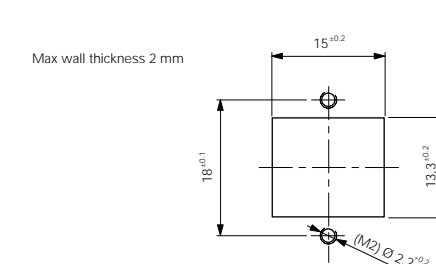

Order Number Codes for Mating Adapters

- ¹ Code for fixation type
 - 0 for basic body
 - 1 for assembled screw fixing clip
 - 2 for assembled quick fixing clip
- ² Code for mechanical keying
- ³ Code for color coding

Other fixations or colors upon request.