

Rugged Horizontal SMT

1 thru 10 High Speed Modules
0 thru 50 Signal Contacts

MKHS

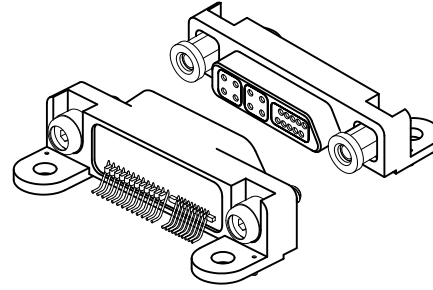

MKHS-02R1-200-275-2810

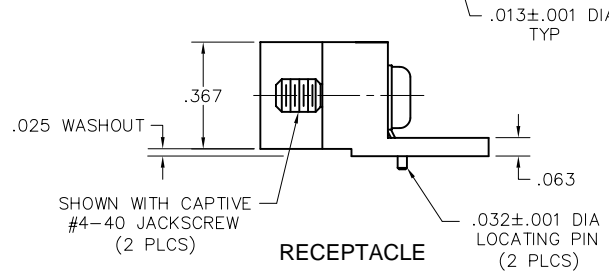
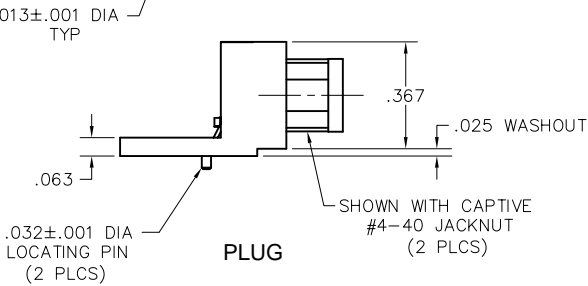
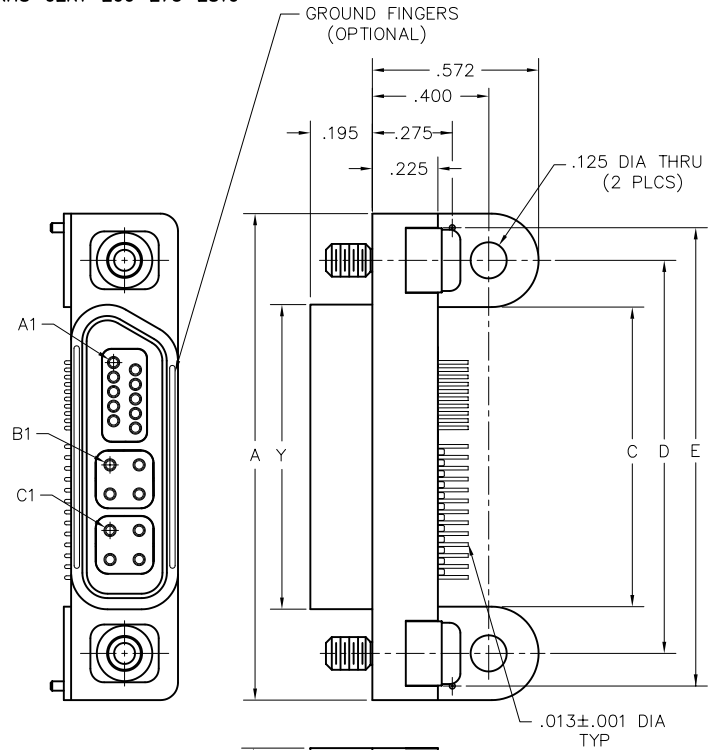
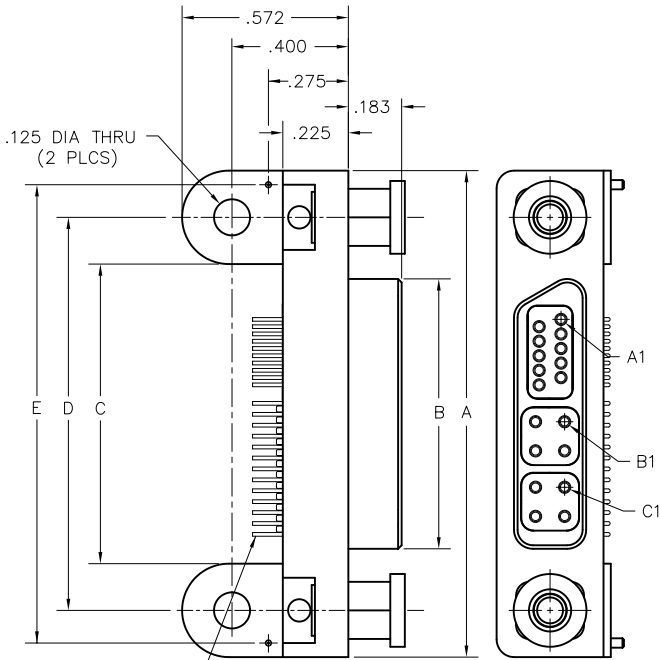

INTERFACE DIMENSIONS

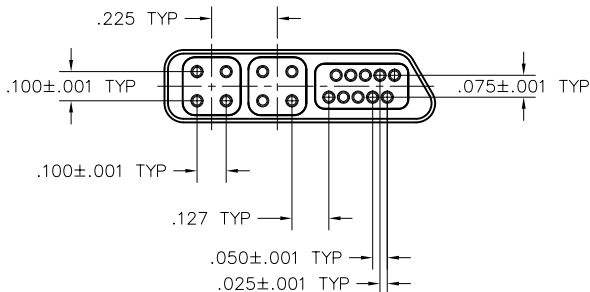

DIMENSIONS	
A	BODY LENGTH PER TABLE CALCULATION (SEE PAGE 6)
B	"A" MINUS 0.744
C	"A" MINUS 0.640
D	"A" MINUS 0.320
E	"A" MINUS 0.096
Y	"A" MINUS 0.624

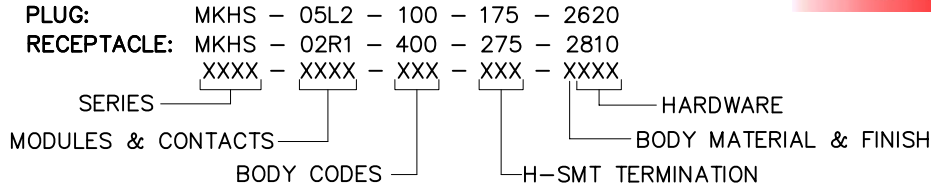

PLUG

SERIES

MKHS HIGH SPEED Rugged Metal Horizontal SMT
(MKHS mates with MMHS, MJHS receptacles)

HIGH SPEED MODULES

01 1 High Speed Module
 02 2 High Speed Modules
 03 3 High Speed Modules
 04 4 High Speed Modules
 05 5 High Speed Modules (Max Signal Count 40)
 06 6 High Speed Modules (Max Signal Count 30)
 07 7 High Speed Modules (Max Signal Count 20)
 08 8 High Speed Modules (Max Signal Count 10)
 09 9 High Speed Modules (Max Signal Count 10)
 0A 10 High Speed Modules (No Signals)

SIGNAL CONTACTS*

L0 Left Side Key - No Signal Contacts
 L1 Left Side Key - 10 Signal Contacts
 L2 Left Side Key - 20 Signal Contacts
 L3 Left Side Key - 30 Signal Contacts
 L4 Left Side Key - 40 Signal Contacts
 L5 Left Side Key - 50 Signal Contacts
 R0 Right Side Key - No Signal Contacts
 R1 Right Side Key - 10 Signal Contacts
 R2 Right Side Key - 20 Signal Contacts
 R3 Right Side Key - 30 Signal Contacts
 R4 Right Side Key - 40 Signal Contacts
 R5 Right Side Key - 50 Signal Contacts

BODY STYLE

100 Plug

CONTACT TERMINATION

17 Pin, Horizontal SMT

TERMINATION PLATING

5 50 micro" Gold Contact, Sn/Pb Alloy Termination
 7 50 micro" Gold Contact, SAC305 Plated Termination

BODY PLATING (LCP INSULATORS)

2 Electroless Nickel Plated Aluminum Shell
 3 Electrodeposited Cadmium Plated Aluminum Shell
 6 Gold Plated Aluminum Shell

HARDWARE

000 No Hardware
 620 Two Fixed Jacknuts - Captivated **
 810 Two Turning Jackscrews, Allen Head, Captivated **
 NXX Keying Jackpost Hardware, See Options ***
 JXX Keying Jackscrew Hardware, See Options ***

RECEPTACLE

SERIES

MKHS HIGH SPEED Rugged Metal Horizontal SMT
(MKHS mates with MMHS, MJHS plugs)

HIGH SPEED MODULES

01 1 High Speed Module
 02 2 High Speed Modules
 03 3 High Speed Modules
 04 4 High Speed Modules
 05 5 High Speed Modules (Max Signal Count 40)
 06 6 High Speed Modules (Max Signal Count 30)
 07 7 High Speed Modules (Max Signal Count 20)
 08 8 High Speed Modules (Max Signal Count 10)
 09 9 High Speed Modules (Max Signal Count 10)
 0A 10 High Speed Modules (No Signals)

SIGNAL CONTACTS*

L0 Left Side Key - No Signal Contacts
 L1 Left Side Key - 10 Signal Contacts
 L2 Left Side Key - 20 Signal Contacts
 L3 Left Side Key - 30 Signal Contacts
 L4 Left Side Key - 40 Signal Contacts
 L5 Left Side Key - 50 Signal Contacts
 R0 Right Side Key - No Signal Contacts
 R1 Right Side Key - 10 Signal Contacts
 R2 Right Side Key - 20 Signal Contacts
 R3 Right Side Key - 30 Signal Contacts
 R4 Right Side Key - 40 Signal Contacts
 R5 Right Side Key - 50 Signal Contacts

BODY STYLE

200 Receptacle
 400 Receptacle with Ground Fingers (Preferred)

CONTACT TERMINATION

27 Socket, Horizontal SMT

TERMINATION PLATING

5 50 micro" Gold Contact, Sn/Pb Alloy Termination
 7 50 micro" Gold Contact, SAC305 Plated Termination

BODY PLATING (LCP INSULATORS)

2 Electroless Nickel Plated Aluminum Shell
 3 Electrodeposited Cadmium Plated Aluminum Shell
 6 Gold Plated Aluminum Shell

HARDWARE

000 No Hardware
 620 Two Fixed Jacknuts - Captivated **
 810 Two Turning Jackscrews, Allen Head, Captivated **
 NXX Keying Jackpost Hardware, See Options ***
 JXX Keying Jackscrew Hardware, See Options ***

NOTES:

1. All high-speed receptacles have fluoropolymer interfacial seals.

= Option not RoHS compliant

* = Left and right key is determined by looking at the PLUG interface with the LONG SIDE downward. The key is the angled side of the interface.

** = Captivated hardware is factory installed and non-removable.

*** = Refer to catalog Page 29 for keying options.

Recommended PC Board Layout Receptacle

RUGGED H-SMT

RECEPTACLE, RIGHT SIDE KEY
 INSULATOR A = SIGNAL CONTACTS
 2 MODULES + SIGNAL SHOWN
 PC BOARD LAYOUT
 COMPONENT SIDE

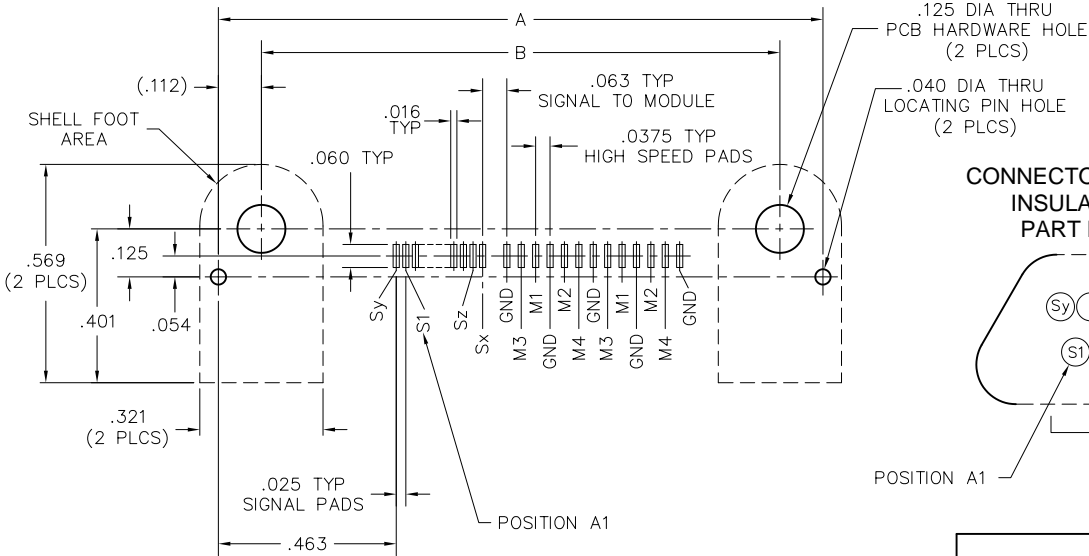

CONNECTOR MATING FACE (RECEPTACLE)
 INSULATOR A = SIGNAL CONTACTS
 PART NUMBER = RIGHT SIDE KEY

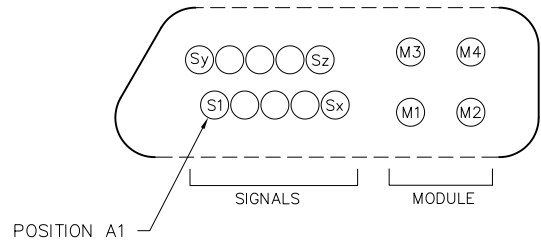

DIMENSIONS	
A	BODY LENGTH PER TABLE CALCULATION (SEE PAGE 6) MINUS 0.097
B	"A" MINUS 0.224

RECEPTACLE, LEFT SIDE KEY
 INSULATOR A = MODULE CONTACTS
 2 MODULES + SIGNAL SHOWN
 PC BOARD LAYOUT
 COMPONENT SIDE

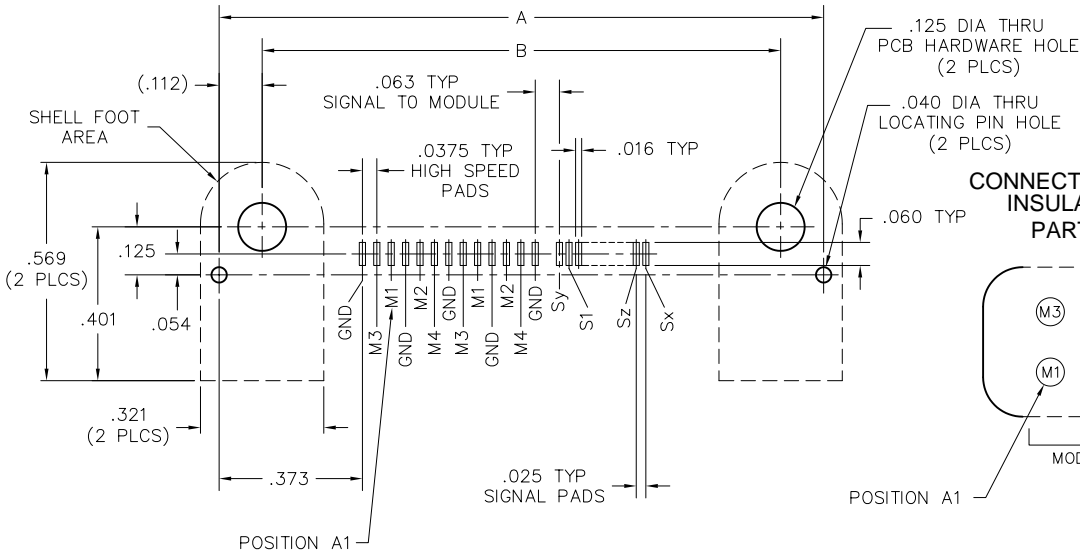

CONNECTOR MATING FACE (RECEPTACLE)
 INSULATOR A = MODULE CONTACTS
 PART NUMBER = LEFT SIDE KEY

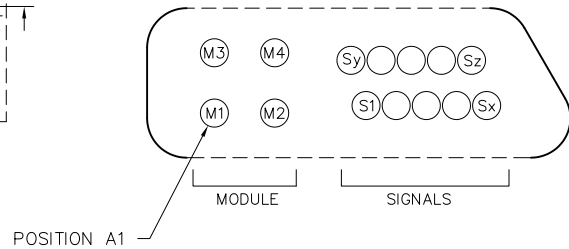

SIGNAL CONTACT NUMBERING					
	SIG10	SIG20	SIG30	SIG40	SIG50
Zx	5	10	15	20	25
Zy	6	11	16	21	26
Zz	10	20	30	40	50

NOTES:

1. Connector module leads M3 and M4 are .080" longer than M1 and M2 PCB traces or IC programming will be required to compensate for this.
2. Receptacle interface key is swapped left-to-right from part number callout when looking at the receptacle interface.