

March 1996

### Features

- Devices QML Qualified in Accordance with MIL-PRF-38535
- Detailed Electrical and Screening Requirements are Contained in SMD# 5962-95636 and Harris' QM Plan
- Fast 125ns Machine Cycle
- 1.2μM TSOS4 CMOS/SOS Process
- Total Dose Capability 300K Rad(Si)
- Single Event Upset Critical LET >120MeV/mg/cm<sup>2</sup>
- Single Event Upset Error Rate <1 x 10<sup>-10</sup> Errors/Bit-Day (See Note)
- -55°C - 125°C, 5V ±10% Operation
- Single Cycle Instruction Execution
- Fast Arithmetic Operations
  - Single Cycle 16-Bit Multiply
  - Single Cycle 16-Bit Multiply Accumulate
  - Single Cycle 32-Bit Barrel Shift
  - Hardware Floating Point Support
- C Software Development Environment
- Direct Execution of Forth Language
- Single Cycle Subroutine Call/Return
- Four Cycle Interrupt Latency
- On-Chip Interrupt Controller
- Three On-Chip 16-Bit Timer/Counters
- Two On-Chip 256 Word Stacks
- ASIC Bus™ for Off-Chip Architecture Extension
- 1 Megabyte Total Address Space
- Word and Byte Memory Access
- Fully Static Design - DC to 8MHz Operation
- 84 Lead Quad Flat Package or 85 Pin Grid Array
- Third Party Software and Hardware Development Systems

NOTE: Single Event Upset error rates are Adams 10% worst case environment under worst case conditions for upset.

### Applications

- Space Systems Embedded Control
- Digital Filtering
- Image Processing
- Scientific Instrumentation
- Optical Systems
- Control Systems
- Attitude/Orbital Control

### Description

The HS-RTX2010RH is a radiation-hardened 16-bit microcontroller with on-chip timers, an interrupt controller, a multiply-accumulator, and a barrel shifter. It is particularly well suited for space craft environments where very high speed control tasks which require arithmetically intensive calculations, including floating point math to be performed in hostile space radiation environments.

This processor incorporates two 256-word stacks with multitasking capabilities, including configurable stack partitioning and over/underflow control.

Instruction execution times of one or two machine cycles are achieved by utilizing a stack oriented, multiple bus architecture. The high performance ASIC Bus, which is unique to the RTX product, provides for extension of the microcontroller architecture using off-chip hardware and application specific I/O devices.

RTX Microcontrollers support the C and Forth programming languages. The advantages of this product are further enhanced through third party hardware and software support.

Combined, these features make the HS-RTX2010RH an extremely powerful processor serving numerous applications in high performance space systems. The HS-RTX2010RH has been designed for harsh space radiation environments and features outstanding Single Event Upset (SEU) resistance and excellent total dose response.

### Ordering Information

PART NUMBER	TEMP. RANGE	SCREENING LEVEL	PACKAGE
5962R9563601QXC	-55°C to +125°C	MIL-PRF-38535 Level Q	85 Pin CPGA
5962R9563601QYC	-55°C to +125°C	MIL-PRF-38535 Level Q	84 Pin CQFP
5962R9563601VXC	-55°C to +125°C	MIL-PRF-38535 Level Q	85 Pin CPGA
5962R9563601VYC	-55°C to +125°C	MIL-PRF-38535 Level Q	84 Pin CQFP
HS8-RTX2010RH/Sample	+25°C	Sample	85 Pin CPGA
HS8-RTX2010RH/Proto	-55°C to +125°C	Prototype	85 Pin CPGA
HS9-RTX2010RH/Sample	+25°C	Sample	84 Pin CQFP
HS9-RTX2010RH/Proto	-55°C to +125°C	Prototype	84 Pin CQFP

# HS-RTX2010RH

## Block Diagram

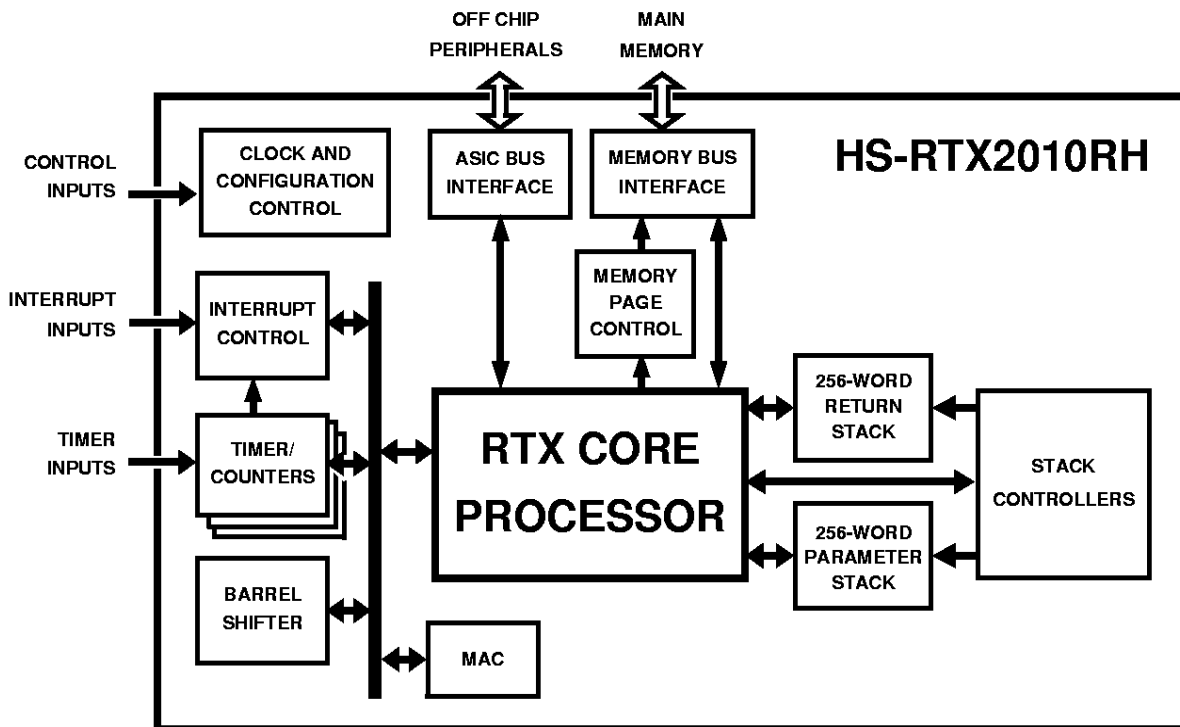

# HS-RTX2010RH

## Pinouts

HS8-RTX2010RH  
MIL-STD-1835 CMGA3-P85C

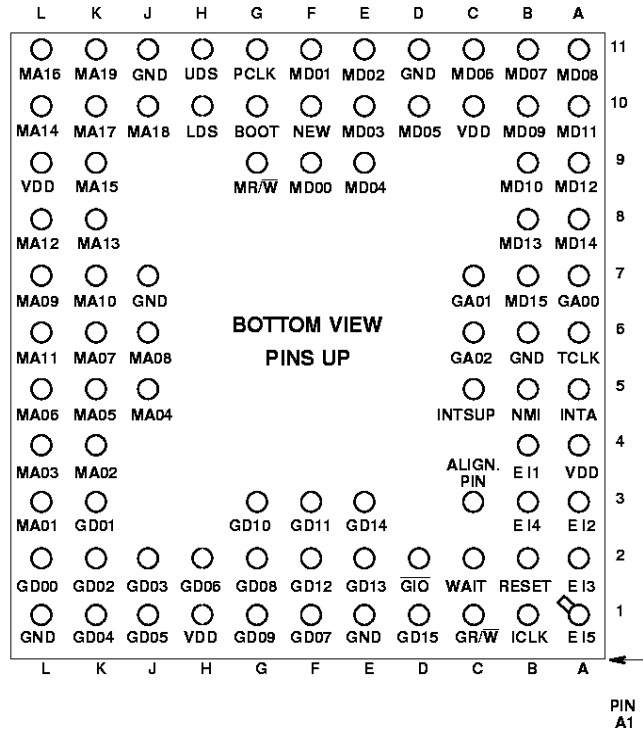
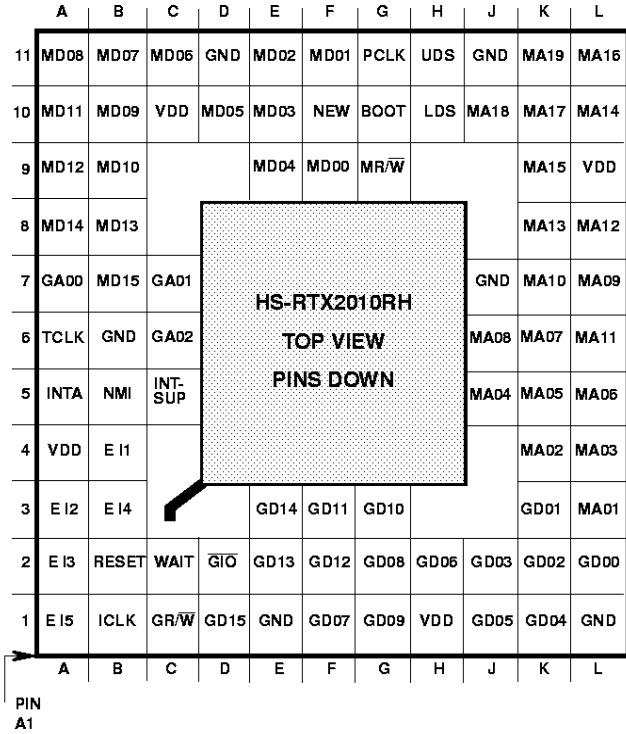

HS9-RTX2010RH  
(LEAD LENGTH NOT TO SCALE)  
SEE HARRIS OUTLINE R84.A

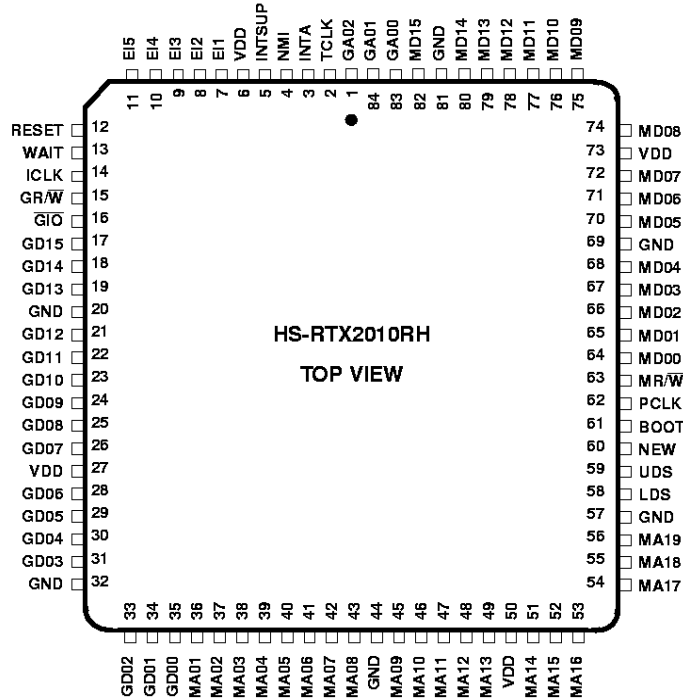

NOTE: An overbar on a signal name represents an active LOW signal.

## HS-RTX2010RH

### PGA And CQFP Pin/Signal Assignments

CQFP	PGA PIN	SIGNAL NAME	TYPE
1	C6	GA02	Output; Address Bus
2	A6	TCLK	Output
3	A5	INTA	Output
4	B5	NMI	Input
5	C5	INTSUP	Input
6	A4	VDD	Power
7	B4	EI1	Input
8	A3	EI2	Input
9	A2	EI3	Input
10	B3	EI4	Input
11	A1	EI5	Input
12	B2	RESET	Input
13	C2	WAIT	Input
14	B1	ICLK	Input
15	C1	GR/W	Output
16	D2	GIO	Output
17	D1	GD15	I/O; Data Bus
18	E3	GD14	I/O; Data Bus
19	E2	GD13	I/O; Data Bus
20	E1	GND	Ground
21	F2	GD12	I/O; Data Bus
22	F3	GD11	I/O; Data Bus
23	G3	GD10	I/O; Data Bus
24	G1	GD09	I/O; Data Bus
25	G2	GD08	I/O; Data Bus
26	F1	GD07	I/O; Data Bus
27	H1	VDD	Power
28	H2	GD06	I/O; Data Bus
29	J1	GD05	I/O; Data Bus
30	K1	GD04	I/O; Data Bus
31	J2	GD03	I/O; Data Bus
32	L1	GND	Ground
33	K2	GD02	I/O; Data Bus
34	K3	GD01	I/O; Data Bus
35	L2	GD00	I/O; Data Bus
36	L3	MA01	Output; Address Bus
37	K4	MA02	Output; Address Bus
38	L4	MA03	Output; Address Bus
39	J5	MA04	Output; Address Bus
40	K5	MA05	Output; Address Bus
41	L5	MA06	Output; Address Bus
42	K6	MA07	Output; Address Bus

CQFP	PGA PIN	SIGNAL NAME	TYPE
43	J6	MA08	Output; Address Bus
44	J7	GND	Ground
45	L7	MA09	Output; Address Bus
46	K7	MA10	Output; Address Bus
47	L6	MA11	Output; Address Bus
48	L8	MA12	Output; Address Bus
49	K8	MA13	Output; Address Bus
50	L9	VDD	Power
51	L10	MA14	Output; Address Bus
52	K9	MA15	Output; Address Bus
53	L11	MA16	Output; Address Bus
54	K10	MA17	Output; Address Bus
55	J10	MA18	Output; Address Bus
56	K11	MA19	Output; Address Bus
57	J11	GND	Ground
58	H10	LDS	Output
59	H11	UDS	Output
60	F10	NEW	Output
61	G10	BOOT	Output
62	G11	PCLK	Output
63	G9	MR/W	Output
64	F9	MD00	I/O; Data Bus
65	F11	MD01	I/O; Data Bus
66	E11	MD02	I/O; Data Bus
67	E10	MD03	I/O; Data Bus
68	E9	MD04	I/O; Data Bus
69	D11	GND	Ground
70	D10	MD05	I/O; Data Bus
71	C11	MD06	I/O; Data Bus
72	B11	MD07	I/O; Data Bus
73	C10	VDD	Power
74	A11	MD08	I/O; Data Bus
75	B10	MD09	I/O; Data Bus
76	B9	MD10	I/O; Data Bus
77	A10	MD11	I/O; Data Bus
78	A9	MD12	I/O; Data Bus
79	B8	MD13	I/O; Data Bus
80	A8	MD14	I/O; Data Bus
81	B6	GND	Ground
82	B7	MD15	I/O; Data Bus
83	A7	GA00	Output; Address Bus
84	C7	GA01	Output; Address Bus
-	C3	-	Isolated Alignment Pin

**Output Signal Descriptions**

SIGNAL	CQFP	RESET LEVEL	DESCRIPTION
<b>OUTPUTS</b>			
NEW	60	1	NEW: A HIGH on this pin indicates that an Instruction Fetch is in progress.
BOOT	61	1	BOOT: A HIGH on this pin indicates that Boot Memory is being accessed. This pin can be set or reset by accessing bit 3 of the Configuration Register.
MR/W	63	1	MEMORY READ/WRITE: A LOW on this pin indicates that a Memory Write operation is in progress.
UDS	59	1	UPPER DATA SELECT: A HIGH on this pin indicates that the high byte of memory (MD15-MD08) is being accessed.
LDS	58	1	LOWER DATA SELECT: A HIGH on this pin indicates that the low byte of memory (MD07-MD00) is being accessed.
GIO	16	1	ASIC I/O: A LOW on this pin indicates that an ASIC Bus operation is in progress.
GR/W	15	1	ASIC READ/WRITE: A LOW on this pin indicates that an ASIC Bus Write operation is in progress.
PCLK	62	0	PROCESSOR CLOCK: Runs at half the frequency of ICLK. All processor cycles begin on the rising edge of PCLK. Held low extra cycles when WAIT is asserted.
TCLK	2	0	TIMING CLOCK: Same frequency and phase as PCLK but continues running during Wait cycles.
INTA	3	0	INTERRUPT ACKNOWLEDGE: A HIGH on this pin indicates that an Interrupt Acknowledge cycle is in progress.

**Input Signal, Bus, And Power Connection Descriptions**

SIGNAL	CQFP LEAD	DESCRIPTION
<b>INPUTS</b>		
WAIT	13	WAIT: A HIGH on this pin causes PCLK to be held LOW and the current cycle to be extended.
ICLK	14	INPUT CLOCK: Internally divided by 2 to generate all on-chip timing (CMOS input levels).
RESET	12	A HIGH level on this pin resets the RTX. Must be held high for at least 4 rising edges of ICLK plus 12 ICLK cycle setup and hold times.
EI2, EI1	8, 7	EXTERNAL INTERRUPTS 2, 1: Active HIGH level-sensitive inputs to the Interrupt Controller. Sampled on the rising edge of PCLK. See Timing Diagrams for detail.
EI5-EI3	11-9	EXTERNAL INTERRUPTS 5, 4, 3: Dual purpose inputs; active HIGH level-sensitive Interrupt Controller inputs; active HIGH edge-sensitive Timer/Counter inputs. As interrupt inputs, they are sampled on the rising edge of PCLK. See Timing Diagrams for detail.
NMI	4	NON-MASKABLE INTERRUPT: Active HIGH edge-sensitive Interrupt Controller input capable of interrupting any processor cycle when NMI is set to Mode 0. See the Interrupt Suppression and Interrupt Controller Sections.
INTSUP	5	INTERRUPT SUPPRESS: A HIGH on this pin inhibits all maskable interrupts, internal and external.

**HS-RTX2010RH**

**Input Signal, Bus, And Power Connection Descriptions** (Continued)

SIGNAL	CQFP LEAD	DESCRIPTION
ADDRESS BUSES (OUTPUTS)		
GA02	1	ASIC ADDRESS: 3-bit ASIC Address Bus, which carries address information for external ASIC devices.
GA01	84	
GA00	83	
MA19-MA14	56-51	MEMORY ADDRESS: 19-bit Memory Address Bus, which carries address information for Main Memory.
MA13-MA09	49-45	
MA08-MA01	43-36	
DATA BUSES (I/O)		
GD15-GD13	17-19	ASIC DATA: 16-bit bidirectional external ASIC Data Bus, which carries data to and from off-chip I/O devices.
GD12-GD07	21-26	
GD06-GD03	28-31	
GD02-GD00	33-35	
MD15	82	MEMORY DATA: 16-bit bidirectional Memory Data Bus, which carries data to and from Main Memory.
MD14-MD08	80-74	
MD07-MD05	72-70	
MD04-MD00	68-64	
POWER CONNECTIONS		
VDD	6, 27, 50, 73	Power supply +5V connections. A 0.1 $\mu$ F, low impedance decoupling capacitor should be placed between VDD and GND. This should be located as close to the RTX package as possible.
GND	20, 32, 44, 57, 69, 81	Power supply ground return connections.

# Specifications HS-RTX2010RH

## Absolute Maximum Ratings

Supply Voltage	.....+6.0V
Input, Output I/O Voltage Applied	..... GND -0.3V to VDD +0.3V
Storage Temperature Range	.....-65°C to +150°C
Junction Temperature	..... +175°C
Lead Temperature (Soldering, 10s)	..... +300°C

## Reliability Information

Thermal Resistance	$\theta_{JA}$	$\theta_{JC}$
CPGA Package	29°C/W	3°C/W
CQFP Package	34°C/W	4°C/W
Maximum Package Power Dissipation	..... 2.0W	
Gate Count	..... 34,000 Gates	

*CAUTION: Stresses above those listed in "Absolute Maximum Ratings" may cause permanent damage to the device. This is a stress only rating and operation of the device at these or any other conditions above those indicated in the operational sections of this specification is not implied.*

## Operating Conditions

Operating Supply Voltage Range, VDD	..... +4.5V to +5.5V	Maximum Rise and Fall Time	..... 5ns Max
Operating Temperature Range, T <sub>A</sub>	..... -55°C to +125°C		

**TABLE 1. DC ELECTRICAL PERFORMANCE CHARACTERISTICS**

PARAMETERS	SYMBOL	CONDITIONS	GROUP A SUBGROUPS	TEMPERATURE	LIMITS		UNITS
					MIN	MAX	
Input High Voltage	VIH	VDD = 5.5V (Note 8)	1, 2, 3	-55°C, +25°C, +125°C	0.7 VDD	-	V
Input Low Voltage	VIL	VDD = 4.5V (Note 8)	1, 2, 3	-55°C, +25°C, +125°C	-	0.8	V
High Output Voltage	VOH1	VDD = 4.5V, IOH = -4.0mA	1, 2, 3	-55°C, +25°C, +125°C	3.5	-	V
High Output Voltage	VOH2	VDD = 4.5V, IOH = -100µA	1, 2, 3	-55°C, +25°C, +125°C	VDD -0.4	-	V
Low Output Voltage	VOL	VDD = 4.5V, IOL = 4.0mA	1, 2, 3	-55°C, +25°C, +125°C	-	0.4	V
Input Leakage Current	II	VDD = 5.5V, VIN = 0V or VDD	1, 3	-55°C, +25°C	-1.0	1.0	µA
			2	+125°C	-5.0	5.0	µA
I/O Leakage Current	IIO	VDD = 5.5V, VIN = 0V or VDD	1, 2, 3	-55°C, +25°C, +125°C	-10.0	10.0	µA
Standby Power Supply Current	ICCSB	VIN = VDD or 0V (Note 7)	1, 3	-55°C, +25°C	-	500	µA
			2	+125°C	-	15	mA
Operating Power Supply Current	ICCOP	VIN = VDD or 0V, ICLK = 1MHz (Note 1)	1, 2, 3	-55°C, +25°C, +125°C	-	40	mA
Functional Test	FT	4.5V, 5.0V and 5.5V	7, 8A, 8B	-55°C, +25°C, +125°C	-	-	-

**TABLE 2. AC ELECTRICAL PERFORMANCE CHARACTERISTICS**

Test Conditions are VDD = 4.5V and 5.5V, VIH = 4.0V, VIL = 0.4V, CL = 50pF, Unless Otherwise Specified

PARAMETERS	SYMBOL	CONDITIONS	GROUP A SUBGROUPS	TEMPERATURE	LIMITS		UNITS
					MIN	MAX	
<b>CLOCK, WAIT AND TIMER TIMING REQUIREMENTS</b>							
ICLK Period	t1	Note 8	9, 10, 11	-55°C, +25°C, +125°C	62	-	ns
ICLK High Time	t2	Note 8	9, 10, 11	-55°C, +25°C, +125°C	24	-	ns
ICLK Low Time	t3	Note 8	9, 10, 11	-55°C, +25°C, +125°C	24	-	ns
Wait Setup Time	t4	Note 9	9, 10, 11	-55°C, +25°C, +125°C	5	-	ns
Wait Hold Time	t5	Note 9	9, 10, 11	-55°C, +25°C, +125°C	5	-	ns

## Specifications HS-RTX2010RH

**TABLE 2. AC ELECTRICAL PERFORMANCE CHARACTERISTICS (Continued)**

Test Conditions are VDD = 4.5V and 5.5V, VIH = 4.0V, VIL = 0.4V, CL = 50pF, Unless Otherwise Specified

PARAMETERS	SYMBOL	CONDITIONS	GROUP A SUBGROUPS	TEMPERATURE	LIMITS		UNITS
					MIN	MAX	
EI High to EI High	t6	External Clock/Timer Input (Note 8)	9, 10, 11	-55°C, +25°C, +125°C	t1x4	-	ns
EI High Time	t7	Note 8	9, 10, 11	-55°C, +25°C, +125°C	20	-	ns
EI Low Time	t8	Note 8	9, 10, 11	-55°C, +25°C, +125°C	15	-	ns
<b>CLOCK, WAIT AND TIMER TIMING RESPONSES</b>							
ICLK to TCLK HIGH	t11		9, 10, 11	-55°C, +25°C, +125°C	5	35	ns
TCLK Low Time	t12	Note 2	9, 10, 11	-55°C, +25°C, +125°C	52	-	ns
TCLK High Time	t13		9, 10, 11	-55°C, +25°C, +125°C	55	-	ns
ICLK to PCLK High	t15		9, 10, 11	-55°C, +25°C, +125°C	5	35	ns
PCLK LOW Time	t16	Notes 2, 3	9, 10, 11	-55°C, +25°C, +125°C	55	-	ns
PCLK HIGH Time	t17		9, 10, 11	-55°C, +25°C, +125°C	55	-	ns
ICLK to TCLK Low	t19		9, 10, 11	-55°C, +25°C, +125°C	-	36	ns
ICLK to PCLK Low	t20		9, 10, 11	-55°C, +25°C, +125°C	-	35	ns
<b>MEMORY BUS TIMING REQUIREMENTS</b>							
MD Setup Time	t21	Read Cycle (Note 9)	9, 10, 11	-55°C, +25°C, +125°C	25	-	ns
MD Hold Time	t22	Note 9	9, 10, 11	-55°C, +25°C, +125°C	4	-	ns
<b>MEMORY BUS TIMING RESPONSES</b>							
PCLK to MA Valid	t26	Note 4	9, 10, 11	-55°C, +25°C, +125°C	-	62	ns
MA Hold Time	t28	Note 4	9, 10, 11	-55°C, +25°C, +125°C	20	-	ns
PCLK to MR/ $\bar{W}$ UDS, LDS, NEW and BOOT Valid	t29	Note 4	9, 10, 11	-55°C, +25°C, +125°C	-	50	ns
MR/ $\bar{W}$ UDS, LDS, NEW, and BOOT Hold Time	t31	Note 4	9, 10, 11	-55°C, +25°C, +125°C	20	-	ns
PCLK to MD Valid	t32	Write Cycle	9, 10, 11	-55°C, +25°C, +125°C	-	20	ns
MD Hold Time	t33	Write Cycle (Note 4)	9, 10, 11	-55°C, +25°C, +125°C	20	-	ns
MD Enable Time	t34	Write Cycle	9, 10, 11	-55°C, +25°C, +125°C	-3	-	ns
PCLK to MD Disable Time	t35	Write Cycle (Note 4)	9, 10, 11	-55°C, +25°C, +125°C	-	60	ns
<b>ASIC BUS AND INTERRUPT TIMING REQUIREMENTS</b>							
GD Read Setup to PCLK	t40A	Read Cycle Not Streamed (Note 9)	9, 10, 11	-55°C, +25°C, +125°C	55	-	ns
GD Read Setup to PCLK	t40B	Read Cycle Streamed Mode (Note 9)	9, 10, 11	-55°C, +25°C, +125°C	28	-	ns
GD Read Setup to $\bar{G}\bar{I}\bar{O}$	t41A	Read Cycle Not Streamed (Note 9)	9, 10, 11	-55°C, +25°C, +125°C	60	-	ns
GD Read Setup to $\bar{G}\bar{I}\bar{O}$	t41B	Read Cycle Streamed Mode (Note 9)	9, 10, 11	-55°C, +25°C, +125°C	33	-	ns



## Specifications HS-RTX2010RH

**TABLE 2. AC ELECTRICAL PERFORMANCE CHARACTERISTICS (Continued)**

Test Conditions are VDD = 4.5V and 5.5V, VIH = 4.0V, VIL = 0.4V, CL = 50pF, Unless Otherwise Specified

PARAMETERS	SYMBOL	CONDITIONS	GROUP A SUBGROUPS	TEMPERATURE	LIMITS		UNITS
					MIN	MAX	
GD Read Hold from $\overline{\text{G}}\overline{\text{I}}\overline{\text{O}}$	t42	Read Cycle (Note 9)	9, 10, 11	-55°C, +25°C, +125°C	0	-	ns
GD Read Hold from PCLK	t43	Read Cycle (Note 9)	9, 10, 11	-55°C, +25°C, +125°C	0	-	ns
EINMI Setup Time	t44	INT/NMI Cycle (Note 9)	9, 10, 11	-55°C, +25°C, +125°C	40	-	ns
INTSUP Setup Time	t46	Note 9	9, 10, 11	-55°C, +25°C, +125°C	22	-	ns
INTSUP Hold Time	t47	Note 9	9, 10, 11	-55°C, +25°C, +125°C	0	-	ns
<b>ASIC BUS AND INTERRUPT TIMING RESPONSES</b>							
PCLK High to $\overline{\text{G}}\overline{\text{I}}\overline{\text{O}}$ Low	t48	Note 2	9, 10, 11	-55°C, +25°C, +125°C	52	-	ns
$\overline{\text{G}}\overline{\text{I}}\overline{\text{O}}$ Low Time	t49	Notes 2, 6	9, 10, 11	-55°C, +25°C, +125°C	52	-	ns
ICLK High to $\overline{\text{G}}\overline{\text{I}}\overline{\text{O}}$ Low	t50		9, 10, 11	-55°C, +25°C, +125°C	-	43	ns
ICLK High to $\overline{\text{G}}\overline{\text{I}}\overline{\text{O}}$ High	t51		9, 10, 11	-55°C, +25°C, +125°C		40	ns
PCLK to GA Valid	t52	Note 4	9, 10, 11	-55°C, +25°C, +125°C	-	49	ns
$\overline{\text{G}}\overline{\text{I}}\overline{\text{O}}$ to GA Hold Time	t54	Note 4	9, 10, 11	-55°C, +25°C, +125°C	12	-	ns
PCLK to GR/ $\overline{\text{W}}$ Valid	t56	Note 4	9, 10, 11	-55°C, +25°C, +125°C	-	50	ns
$\overline{\text{G}}\overline{\text{I}}\overline{\text{O}}$ to GR/ $\overline{\text{W}}$ Hold Time	t58	Note 4	9, 10, 11	-55°C, +25°C, +125°C	15	-	ns
GD Enable Time	t61	Write Cycle	9, 10, 11	-55°C, +25°C, +125°C	-7	-	ns
GD Valid Time	t62		9, 10, 11	-55°C, +25°C, +125°C	-	16	ns
$\overline{\text{G}}\overline{\text{I}}\overline{\text{O}}$ to GD Hold Time	t63	Write Cycle (Note 4)	9, 10, 11	-55°C, +25°C, +125°C	12	-	ns
$\overline{\text{G}}\overline{\text{I}}\overline{\text{O}}$ to GD Disable Time	t65	Write Cycle (Note 4)	9, 10, 11	-55°C, +25°C, +125°C	-	60	ns
PCLK to INTA High Time	t67	INTA Cycle	9, 10, 11	-55°C, +25°C, +125°C	-	25	ns
INTA Hold Time	t68		9, 10, 11	-55°C, +25°C, +125°C	0	-	ns
$\overline{\text{G}}\overline{\text{I}}\overline{\text{O}}$ High Time	t69	Notes 2, 6	9, 10, 11	-55°C, +25°C, +125°C	52	-	ns

**NOTES:**

1. ICCOP increases approximately 5mA/MHz.
2. Tested with t1 = t1(min). For t1 > t1(min), add t1 - t1(min) to this parameter.
3. If CYCEXT and/or ARCE bit is a set, add 1 x t1(min) to this parameter for USER memory access (CYCEXT case), or external ASIC Bus read (ARCE case).
4. Tested with t1 at specified minimum and t2 = 0.5 x t1. For t2 > 0.5 x t1(min) add t2 - (0.5 x t1(min)) to this parameter.
5. Output enable and disable times are characterized and guaranteed, but not 100% tested.
6. If ARCE bit is set, add 1 x t1(min) to this parameter for external ASIC Read Cycles.
7. Measurement is made with the RAM sense AMPS disabled.
8. Go/No Go Test. There are no recorded measurements.
9. These parameters are given for application purposes and are required for proper operation. The test value measured must be less than the specified minimum or greater than the specified maximum.

## Specifications HS-RTX2010RH

**TABLE 3. DC ELECTRICAL PERFORMANCE CHARACTERISTICS**

PARAMETERS	SYMBOL	CONDITIONS	GROUP A SUBGROUPS	TEMPERATURE	LIMITS			UNITS
					MIN	TYP	MAX	
Input Capacitance	CIN	VCC Open, f = 1 MHz	-	+25°C	-	10	-	pF
I/O Capacitance	CI/O	VCC Open, f = 1 MHz	-	+25°C	-	10	-	pF

NOTE:

1. All measurements referenced to device ground. The values provided in this table are typical measurements only. Harris does not test for these parameters.

**TABLE 4A. POST 300K RAD ELECTRICAL PERFORMANCE CHARACTERISTICS**

PARAMETERS	SYMBOL	CONDITIONS	TEMPERATURE	LIMITS		UNITS
				MIN	MAX	
Input High Voltage	VIH	VDD = 5.5V (Note 8)	+25°C	0.7 VDD	-	V
Input Low Voltage	VIL	VDD = 4.5V (Note 8)	+25°C	-	0.8	V
High Output Voltage	VOH1	VDD = 4.5V, IOH = -4.0mA	+25°C	3.5	-	V
High Output Voltage	VOH2	VDD = 4.5V, IOH = -100µA	+25°C	VDD -0.4	-	V
Low Output Voltage	VOL	VDD = 4.5V, IOL = 4.0mA	+25°C	-	0.4	V
Input Leakage Current	II	VDD = 5.5V, VIN = 0V or VDD	+25°C	-5.0	5.0	µA
I/O Leakage Current	IIO	VDD = 5.5V, VO = 0V or VDD	+25°C	-10.0	10.0	µA
Standby Power Supply Current	ICCSB	VIN = VDD or 0V (Note 7)	+25°C	-	15	mA
Operating Power Supply Current	ICCOP	VIN = VDD or 0V, ICLK = 1MHz (Note 1)	+25°C	-	40	mA
Functional Test	FT	4.5V, 5.0V and 5.5V	+25°C	-	-	-

**TABLE 4B. POST 300K RAD ELECTRICAL PERFORMANCE CHARACTERISTICS**

Test Conditions are VDD = 4.5V and 5.5V, VIH = 4.0V, VIL = 0.4V, CL = 50pF, Unless Otherwise Specified

PARAMETERS	SYMBOL	CONDITIONS	TEMPERATURE	LIMITS		UNITS
				MIN	MAX	
<b>CLOCK, WAIT AND TIMER TIMING REQUIREMENTS</b>						
ICLK Period	t1	Note 8	+25°C	62	-	ns
ICLK High Time	t2	Note 8	+25°C	24	-	ns
ICLK Low Time	t3	Note 8	+25°C	24	-	ns
Wait Setup Time	t4	Note 9	+25°C	5	-	ns
Wait Hold Time	t5	Note 9	+25°C	5	-	ns
EI High to EI High	t6	External Clock/Timer Input (Note 8)	+25°C	t1x4	-	ns

## Specifications HS-RTX2010RH

**TABLE 4B. POST 300K RAD ELECTRICAL PERFORMANCE CHARACTERISTICS (Continued)**

Test Conditions are VDD = 4.5V and 5.5V, VIH = 4.0V, VIL = 0.4V, CL = 50pF, Unless Otherwise Specified

PARAMETERS	SYMBOL	CONDITIONS	TEMPERATURE	LIMITS		UNITS
				MIN	MAX	
EI High Time	t7	Note 8	+25°C	20	-	ns
EI Low Time	t8	Note 8	+25°C	15	-	ns
<b>CLOCK, WAIT AND TIMER TIMING RESPONSES</b>						
ICLK to TCLK HIGH	t11		+25°C	5	35	ns
TCLK Low Time	t12	Note 2	+25°C	52	-	ns
TCLK High Time	t13		+25°C	55	-	ns
ICLK to PCLK High	t15		+25°C	5	35	ns
PCLK Low Time	t16	Notes 2, 3	+25°C	55	-	ns
PCLK High Time	t17		+25°C	55	-	ns
ICLK to TCLK Low	t19		+25°C	-	36	ns
ICLK to PCLK Low	t20		+25°C	-	35	ns
<b>MEMORY BUS TIMING REQUIREMENTS</b>						
MD Setup Time	t21	Read Cycle (Note 9)	+25°C	25	-	ns
MD Hold Time	t22	Note 9	+25°C	4	-	ns
<b>MEMORY BUS TIMING RESPONSES</b>						
PCLK to MA Valid	t26	Note 4	+25°C	-	62	ns
MA Hold Time	t28	Note 4	+25°C	20	-	ns
PCLK to MR/W UDS, LDS, NEW and Boot Valid	t29	Note 4	+25°C	-	50	ns
MR/W UDS, LDS, NEW, and Boot Hold Time	t31	Note 4	+25°C	20	-	ns
PCLK to MD Valid	t32	Write Cycle	+25°C	-	20	ns
MD Hold Time	t33	Write Cycle (Note 4)	+25°C	20	-	ns
MD Enable Time	t34	Write Cycle	+25°C	-3	-	ns
PCLK to MD Disable Time	t35	Write Cycle (Note 4)	+25°C	-	60	ns
<b>ASIC BUS AND INTERRUPT TIMING REQUIREMENTS</b>						
GD Read Setup to PCLK	t40A	Read Cycle Not Streamed (Note 9)	+25°C	55	-	ns
GD Read Setup to PCLK	t40B	Read Cycle Streamed Mode (Note 9)	+25°C	28	-	ns
GD Read Setup to $\overline{G\bar{I}O}$	t41A	Read Cycle Not Streamed (Note 9)	+25°C	60	-	ns

## Specifications HS-RTX2010RH

**TABLE 4B. POST 300K RAD ELECTRICAL PERFORMANCE CHARACTERISTICS (Continued)**

Test Conditions are VDD = 4.5V and 5.5V, VIH = 4.0V, VIL = 0.4V, CL = 50pF, Unless Otherwise Specified

PARAMETERS	SYMBOL	CONDITIONS	TEMPERATURE	LIMITS		UNITS
				MIN	MAX	
GD Read Setup to $\overline{\text{GIO}}$	t41B	Read Cycle Streamed Mode (Note 9)	+25°C	33	-	ns
GD Read Hold from $\overline{\text{GIO}}$	t42	Read Cycle (Note 9)	+25°C	0	-	ns
GD Read Hold from PCLK	t43	Read Cycle (Note 9)	+25°C	0	-	ns
EINMI Setup Time	t44	INT/NMI Cycle (Note 9)	+25°C	40	-	ns
INTSUP Setup Time	t46	Note 9	+25°C	22	-	ns
INTSUP Hold Time	t47	Note 9	+25°C	0	-	ns
<b>ASIC BUS AND INTERRUPT TIMING RESPONSES</b>						
PCLK High to $\overline{\text{GIO}}$ Low	t48	Note 2	+25°C	52	-	ns
$\overline{\text{GIO}}$ Low Time	t49	Notes 2, 6	+25°C	52	-	ns
ICLK High to $\overline{\text{GIO}}$ Low	t50		+25°C	-	43	ns
ICLK High to $\overline{\text{GIO}}$ High	t51		+25°C	-	40	ns
PCLK to GA Valid	t52	Note 4	+25°C	-	49	ns
$\overline{\text{GIO}}$ to GA Hold Time	t54	Note 4	+25°C	12	-	ns
PCLK to GR/ $\overline{\text{W}}$ Valid	t56	Note 4	+25°C	-	50	ns
$\overline{\text{GIO}}$ to GR/ $\overline{\text{W}}$ Hold Time	t58	Note 4	+25°C	15	-	ns
GD Enable Time	t61	Write Cycle	+25°C	-7	-	ns
GD Valid Time	t62		+25°C	-	16	ns
$\overline{\text{GIO}}$ to GD Hold Time	t63	Write Cycle (Note 4)	+25°C	12	-	ns
$\overline{\text{GIO}}$ to GD Disable Time	t65	Write Cycle (Note 4)	+25°C	-	60	ns
PCLK to INTA High Time	t67	INTA Cycle	+25°C	-	25	ns
INTA Hold Time	t68		+25°C	0	-	ns
$\overline{\text{GIO}}$ High Time	t69	Notes 2, 6	+25°C	52	-	ns

**NOTES:**

1. ICCOP increases approximately 5mA/MHz.
2. Tested with t1 = t1(min). For t1 > t1(min), add t1 - t1(min) to this parameter.
3. If CYCEXT and/or ARCE bit is a set, add 1 x t1(min) to this parameter for USER memory access (CYCEXT case), or external ASIC Bus read (ARCE case).
4. Tested with t1 at specified minimum and t2 = 0.5 x t1. For t2 > 0.5 x t1(min) add t2 - (0.5 x t1(min)) to this parameter.
5. Output enable and disable times are characterized and guaranteed, but not 100% tested.
6. If ARCE bit is set, add 1 x t1(min) to this parameter for external ASIC Read Cycles.
7. Measurement is made with the RAM sense AMPS disabled.
8. Go/No Go Test. There are no recorded measurements.
9. These parameters are given for application purposes and are required for proper operation. The test value measured must be less than the specified minimum or greater than the specified maximum.

**HS-RTX2010RH Microcontroller**

The HS-RTX2010RH is designed around the RTX Processor core, which is part of the Harris Standard Cell Library.

This processor core has eight 16-bit internal registers, an ALU, internal data buses, and control hardware to perform instruction decoding and sequencing.

On-chip peripherals which the HS-RTX2010RH includes are Memory Page Controller, an Interrupt Controller, three Timer/Counters, and two Stack Controllers. Also included are a Multiplier-Accumulator (MAC), a Barrel Shifter, and a Leading Zero Detector for floating point support.

Off-chip user interfaces provide address and data access to Main Memory and ASIC I/O devices, user defined interrupt signals, and Clock/Reset controls.

Figure 1 shows the data paths between the core, on-chip peripherals, and off-chip interfaces.

The HS-RTX2010RH microcontroller is based on a two-stack architecture. These two stacks, which are Last-In-First-Out (LIFO) memories, are called the Parameter Stack and the Return Stack.

Two internal registers, **TOP** and **NEXT**, provide the top two elements of the 16-bit wide Parameter Stack, while the remaining elements are contained in on-chip memory ("stack memory").

The top element of the Return Stack is 21 bits wide, and is stored in registers **I** and **IPR**, while the remaining elements are contained in stack memory.

The highly parallel architecture of the RTX is optimized for minimal Subroutine Call/Return overhead. As a result, a Subroutine Call takes one Cycle, while a Subroutine Return is usually incorporated into the preceding instruction and does not add any processor cycles. This parallelism provides for peak execution rates during simultaneous bus operations which can reach the equivalent of 32 million Forth language operations per second at a clock rate of 8MHz. Typical execution rates exceed 8 million operations per second.

Harris factory applications support for this device is limited. RTS-C C-Compiler support is provided by Metsys at (407) 725-0251. Development system tools are supported by Micro Processor Engineering Limited at 441 703 631441. A HS-RTX2010RH programmers reference manual can be obtained through your local Harris Sales Office.

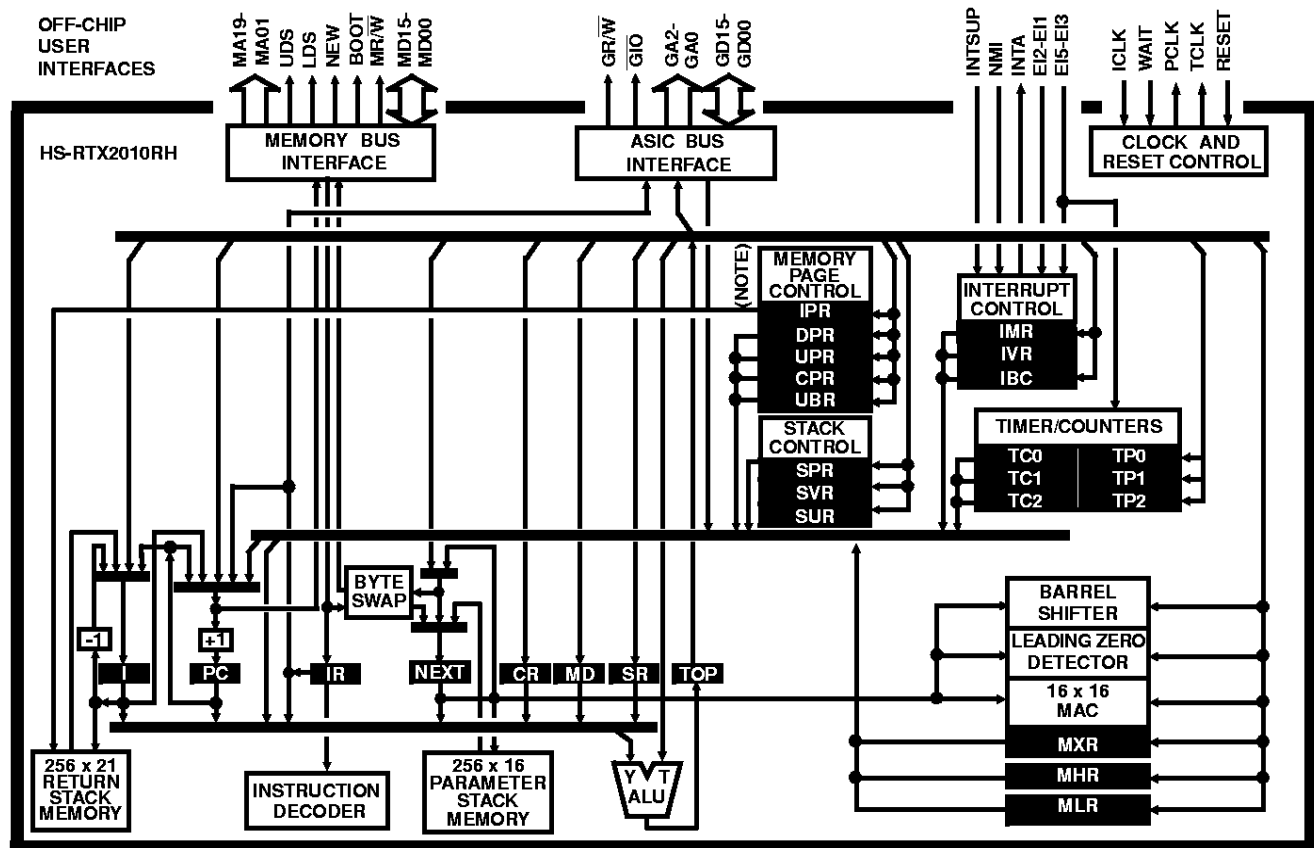

FIGURE 1. HS-RTX2010RH FUNCTIONAL BLOCK DIAGRAM

NOTE: **IPR** contains the 5 most significant bits (20-16) of the top element of the Return Stack.

**HS-RTX2010RH Operation**

Control of all data paths and the Program Counter Register, (PC), is provided by the Instruction Decoder. This hardware determines what function is to be performed by looking at the contents of the Instruction Register, (IR), and subsequently determines the sequence of operations through data path control.

Instructions which do not perform memory accesses execute in a single clock cycle while the next instruction is being fetched.

As shown in Figure 2, the instruction is latched into IR at the beginning of a clock cycle. The instruction is then decoded by the processor. All necessary internal operations are performed simultaneously with fetching the next instruction.

Instructions which access memory require two clock cycles to be executed. During the first cycle of a memory access instruction, the instruction is decoded, the address of the memory location to be accessed is placed on the Memory

Address Bus (MA19-MA01), and the memory data (MD15-MD00), is read or written. During the second cycle, ALU operations are performed, the address of the next instruction to be executed is placed on the Memory Address Bus, and the next instruction is fetched, as indicated in the bottom half of Figure 2.

**RTX Data Buses and Address Buses**

The RTX core bus architecture provides for unidirectional data paths and simultaneous operation of some data buses. This parallelism allows for maximum efficiency of data flow internal to the core.

Addresses for accessing external (off-chip) memory or ASIC devices are output via either the Memory Data Bus (MA19-MA01) or the ASIC Address Bus (GA02-GA00). See Table 3. External data is transferred by the ASIC Data Bus (GD15-GD00) and the Memory Data Bus (MD15-MD00), both of which are bidirectional.

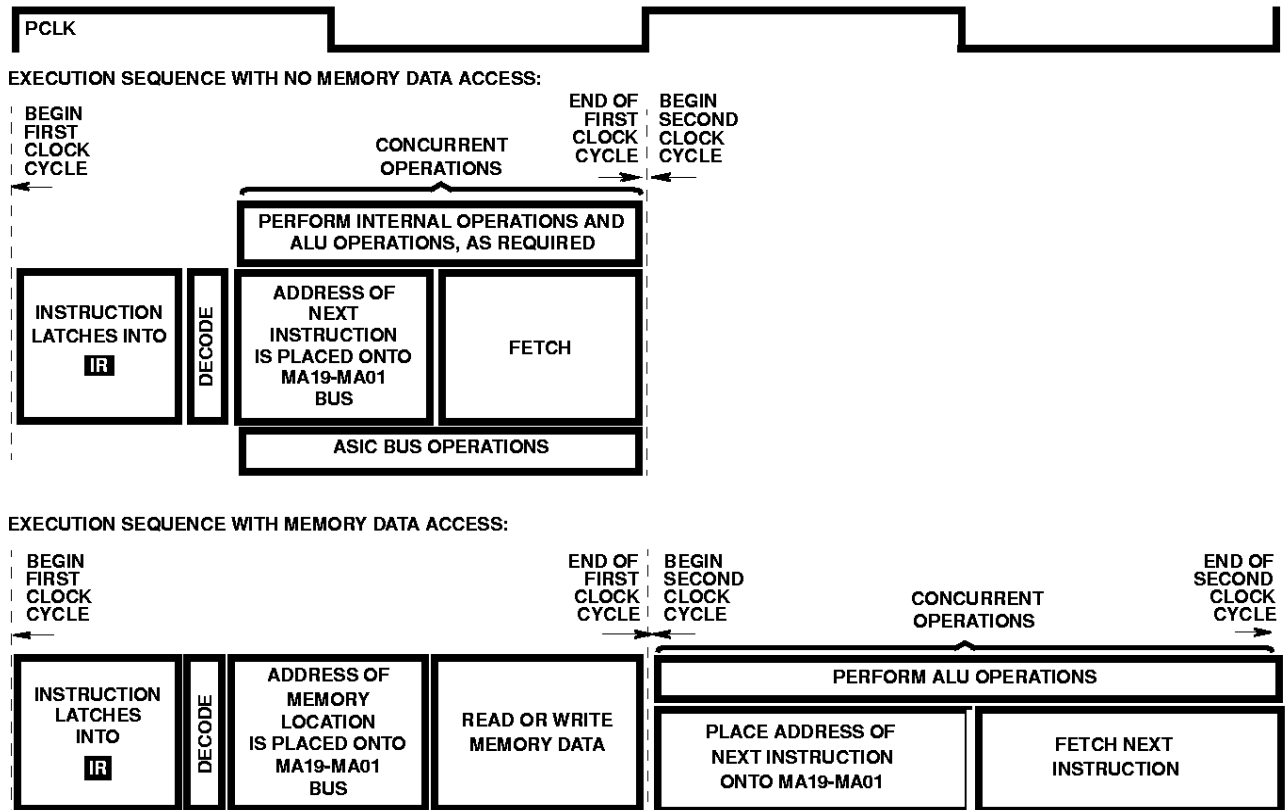

FIGURE 2. INSTRUCTION EXECUTION SEQUENCE

**RTX Internal Registers**

The core of the HS-RTX2010RH is a macrocell available through the Harris Standard Cell Library. This core contains eight 16-bit internal registers, which may be accessed implicitly or explicitly, depending upon the register accessed and the function being performed.

**TOP**: The Top Register contains the top element of the Parameter Stack. **TOP** is the implicit data source or destination for certain instructions, and has no ASIC address assignment. The contents of this register may be directed to any I/O device or to any processor register except the Instruction Register. **TOP** is also the T input to the ALU. Input to **TOP** must come through the ALU. This register also holds the most significant 16 bits of 32-bit products and 32-bit dividends.

**NEXT**: The Next Register holds the second element of the Parameter Stack. **NEXT** is the implicit data source or destination for certain instructions, and has no ASIC address assignment. During a stack "push", the contents of **NEXT** are transferred to stack memory, and the contents of **TOP** are put into **NEXT**. This register is used to hold the least significant 16 bits of 32-bit products. Memory data is accessed through **NEXT**, as described in the Memory Access section of this document.

**IR**: The Instruction Register is actually a latch which contains the instruction currently being executed, and has no ASIC address assignment. In certain instructions, an operand can be embedded in the instruction code, making **IR** the implicit source for that operand (as in the case of short literals). Input to this register comes from Main Memory (see Tables 12 thru 28 for code information).

**CR**: The Configuration Register is used to indicate and control the current status/setup of the RTX microcontroller, through the bit assignments shown in Figure 3. This register is accessed explicitly through read and write operations, which cause interrupts to be suppressed for one cycle, guaranteeing that the next instruction will be performed before an Interrupt Acknowledge cycle is allowed to be performed.

**PC**: The Program Counter Register contains the address of the next instruction to be fetched from Main Memory. At RESET, the contents of **PC** are set to 0.

**I**: The Index Register contains 16 bits of the 21-bit top element of the Return Stack, and is also used to hold the count for streamed and loop instructions (see Figure 11). In addition, **I** can be used to hold data and can be written from **TOP**. The contents of **I** may be accessed in either the push/pop mode in which values are moved to/from stack memory as required, or in the read/write mode in which the stack memory is not affected. The ASIC address used for **I** determines what type of operation will be performed (see Table 11). When the Streamed Instruction Mode (see RTX Programmer's Reference Manual) is used, a count is written to **I** and the next instruction is executed that number of times plus one (i.e. count + 1).

**MD**: The Multi-Step Divide Register holds the divisor during Step Divide operations, while the 32-bit dividend is in **TOP** and **NEXT**. **MD** may also be used as a general purpose scratch pad register.

**SR**: The Square Root Register holds the intermediate values used during Step Square Root calculations. **SR** may also be used as a general purpose scratch pad register.

**On-Chip Peripheral Registers**

The HS-RTX2010RH has an on-chip Interrupt Controller, a Memory Page Controller, two Stack Controllers, three Timer/Counters, a Multiplier-Accumulator, a Barrel Shifter, and a Leading Zero Detector. Each of these peripherals utilizes on-chip registers to perform its functions.

**Timer/Counter Registers**

**TC0**, **TC1**, **TC2**: The Timer/Counter Registers are 16-bit read-only registers which contain the current count value for each of the three Timer/Counters. The counter is decremented at each rising clock edge of TCLK. Reading from these registers at any time does not disturb their contents. The sequence of Timer/Counter operations is shown in Figure 15 in the Timer/Counters section.

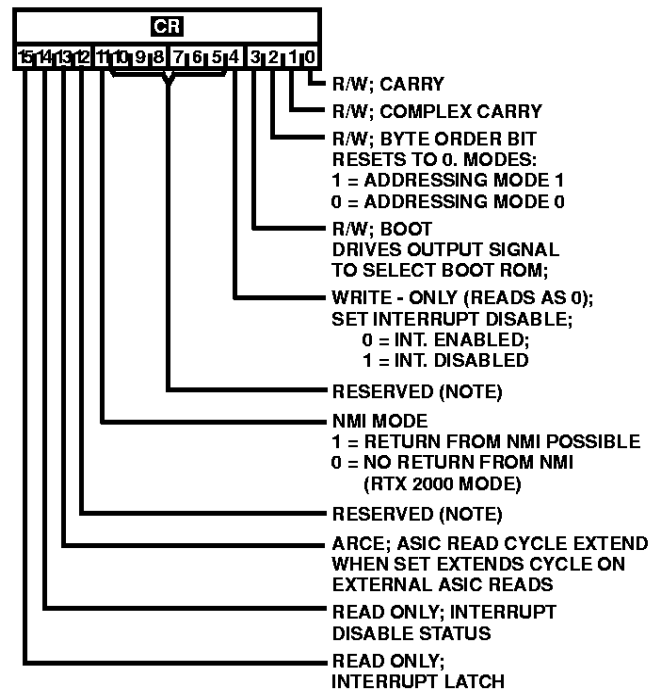

FIGURE 3. **CR** BIT ASSIGNMENTS

NOTE: Always read as "0". Should be set = 0 during Write operations.

**TP0, TP1, TP2**: The Timer Preload Registers are write-only registers which contain the initial 16-bit count values which are written to each timer. After a timer counts down to zero, the preload register for that timer reloads its initial count value to that timer register at the next rising clock edge, synchronously with TCLK. Writing to these registers causes the count to be loaded into the corresponding Timer/Counter register on the following cycle.

**Multiplier-Accumulator (MAC) Registers:**

**MHR**: The Multiplier High Product Register holds the most significant 16 bits of the 32-bit product generated by the RTX Multiplier. If the **IBC** register's ROUND bit is set, this register contains the rounded 16-bit output of the multiplier. In the Accumulator context, this register holds the middle 16 bits of the MAC.

**MLR**: The Multiplier Lower Product Register holds the least significant 16 bits of the 32-bit product generated by the RTX Multiplier. It is also the register which holds the least significant 16 bits of the MAC Accumulator.

**MXR**: The MAC Extension Register holds the most significant 16 bits of the MAC Accumulator. When using the Barrel Shifter, this register holds the shift count. When using the Leading Zero Detector, the leading zero count is stored in this register.

**Interrupt Controller Registers**

**IVR**: The Interrupt Vector Register is a read-only register which holds the current Interrupt Vector value. See Figure 4 and Table 10.

**IBC**: The Interrupt Base/Control Register is used to store the Interrupt Vector base address and to specify configuration information for the processor, as indicated by the bit assignments in Figure 5.

**IMR**: The Interrupt Mask Register has a bit assigned for each maskable interrupt which can occur. When a bit is set, the interrupt corresponding to that bit will be masked. Only the Non-Maskable Interrupt (NMI) cannot be masked. See Figure 6 for bit assignments for this register.

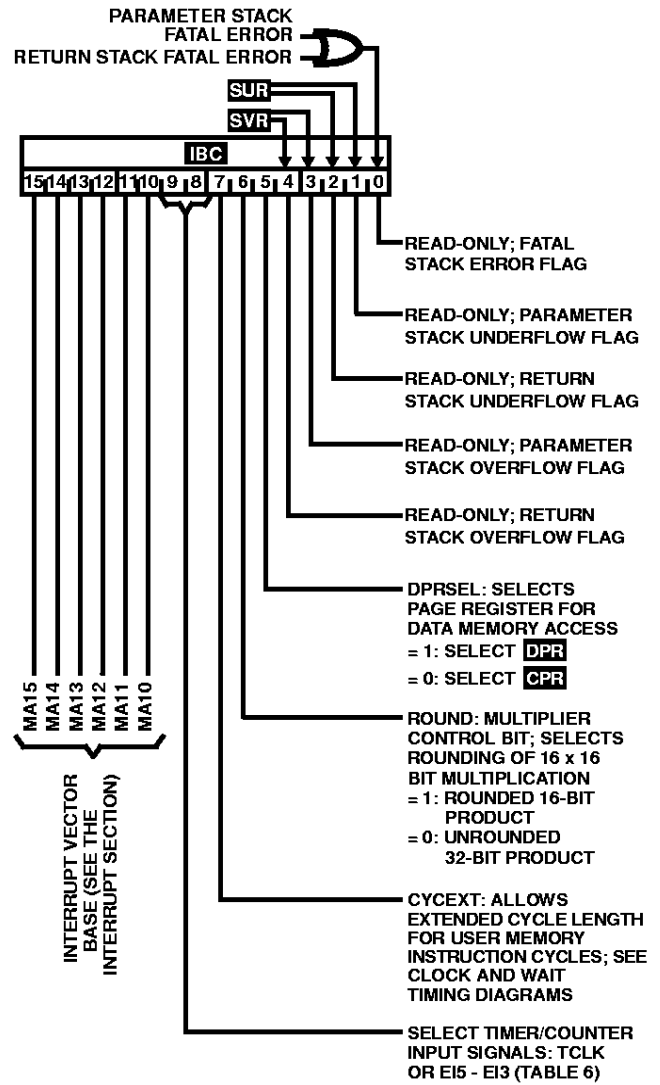

FIGURE 5. **IBC** BIT ASSIGNMENTS

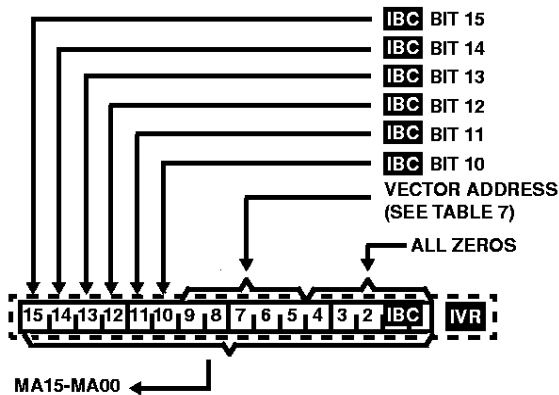

FIGURE 4. **IVR** BIT ASSIGNMENTS

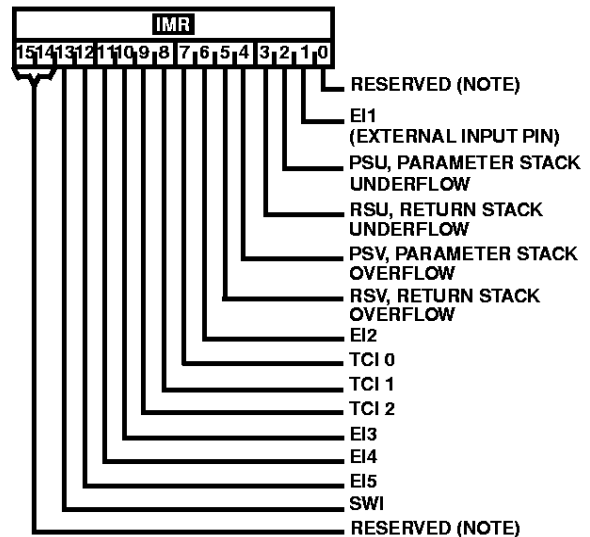

FIGURE 6. **IMR** BIT ASSIGNMENTS

NOTE: Always read as "0". Should be set = 0 during Write operations.



**Stack Controller Registers**

**SPR**: The Stack Pointer Register holds the stack pointer value for each stack. Bits 0-7 represent the next available stack memory location for the Parameter Stack, while bits 8-15 represent the next available stack memory location for the Return Stack. These stack pointer values must be accessed together, as **SPR**. See Figure 7.

**SVR**: The Stack Overflow Limit Register is a write-only register which holds the overflow limit values (0 to 255) for the Parameter Stack (bits 0-7) and the Return Stack (bits 8-15). These values must be written together. See Figure 8.

**SUR**: The Stack Underflow Limit Register holds the underflow limit values for the Parameter Stack and the Return Stack. In addition, this register is utilized to define the use of substacks for both stacks. These values must be accessed together. See Figure 9.

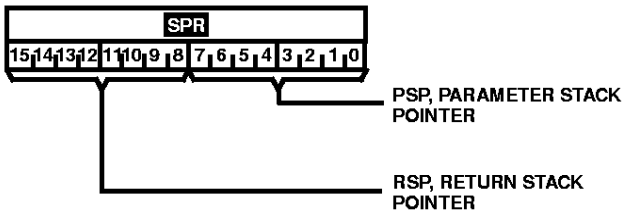

FIGURE 7. **SPR** BIT ASSIGNMENTS

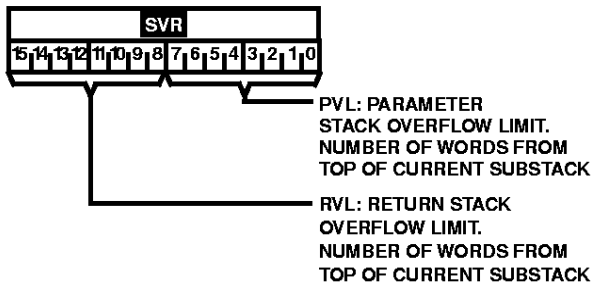

FIGURE 8. **SVR** BIT ASSIGNMENTS

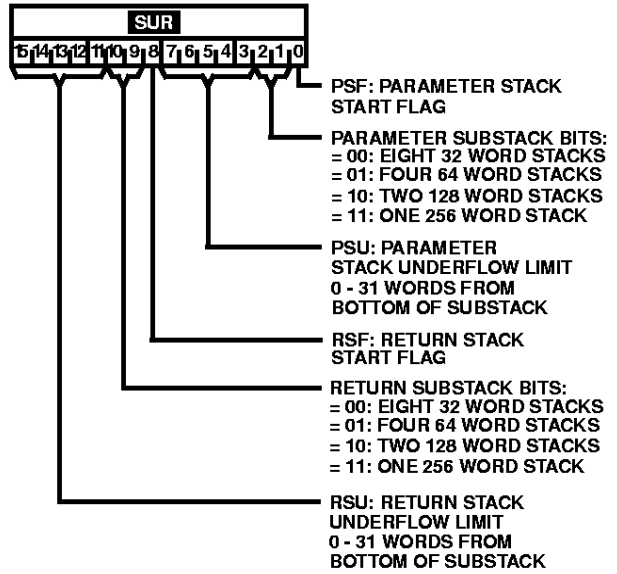

FIGURE 9. **SUR** BIT ASSIGNMENTS

**Memory Page Controller Registers**

**CPR**: The Code Page Register contains the value for the current 32K-word Code page. See Figure 10 for bit field assignments.

**IPR**: The Index Page Register extends the Index Register (**I**) by 5 bits; i.e. when a Subroutine Return is performed, the **IPR** contains the Code page from which the subroutine was called, and comprises the 5 most significant bits of the top element of the Return Stack. See Figure 11. During nonsubroutine operation, writing to **I** causes the current Code page value to be written to **IPR**. Reading or writing directly to **IPR** does not push the Return Stack.

**DPR**: The Data Page Register contains the value for the current 32K-word Data page. See Figure 12 for bit field assignments.

**UPR**: The User Page Register contains the value for the current User page. See Figure 13 for bit field assignments.

**UBR**: The User Base Address Register contains the base address for User Memory Instructions. See Figure 13 for bit field assignments.

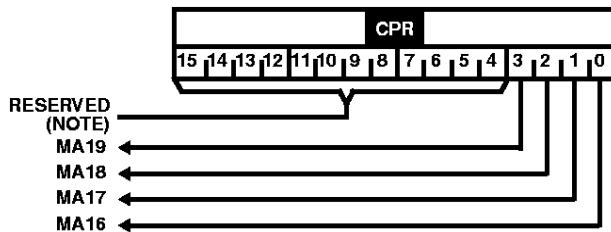

FIGURE 10. **CPR** BIT ASSIGNMENTS

**Initialization of Registers**

Initialization of the on-chip registers occurs when a HIGH level on the RTX RESET pin is held for a period of greater than or equal to four rising edges of ICLK plus 1/2 ICLK cycle setup and hold times. While the RESET input is HIGH, the TCLK and PCLK clock outputs are held reset in the LOW state.

Table 7 shows initialization values and ASIC addresses for the on-chip registers. As indicated, both the **PC** and the **CPR** are cleared and execution begins at page 0, word 0 when the processor is reset.

The RESET has a Schmitt trigger input, which allows the use of a simple RC network for generation of a power-on RESET signal. This helps to minimize the circuit board space required for the RESET circuit.

To ensure reliable operation even in noisy embedded control environments, the RESET input is filtered to prevent a reset caused by a glitch of less than four ICLK cycles duration.

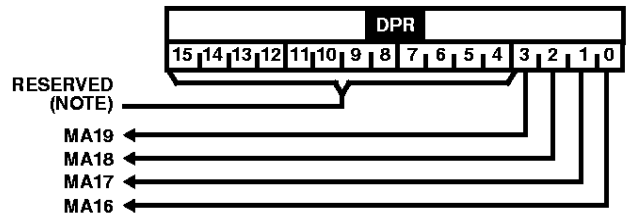
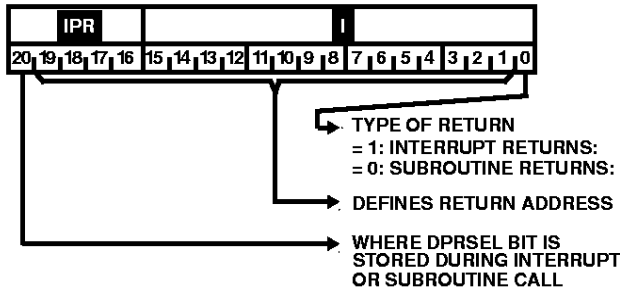

FIGURE 12. **DPR** BIT ASSIGNMENTS

**BIT ASSIGNMENTS DURING SUBROUTINE OPERATIONS**



**BIT ASSIGNMENTS DURING NON-SUBROUTINE OPERATIONS**

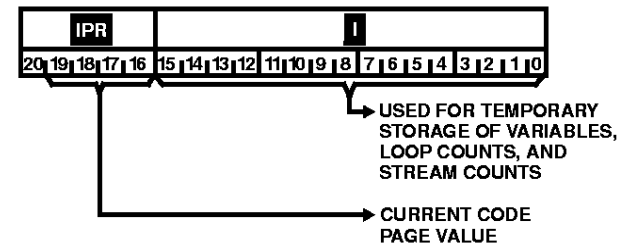

FIGURE 11. **I** AND **IPR** BIT ASSIGNMENTS

NOTE: Always read as "0". Should be set = 0 during Write operations

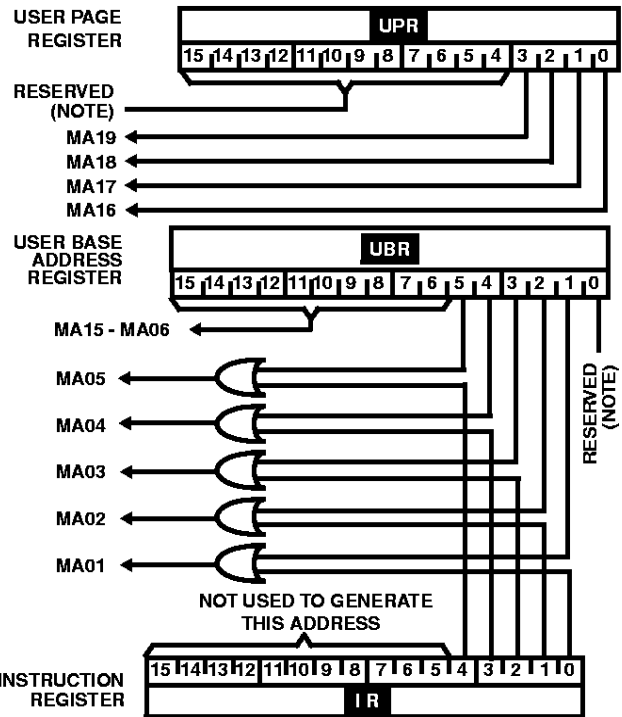

FIGURE 13. **UPR** AND **UBR** BIT ASSIGNMENTS

## HS-RTX2010RH

**TABLE 7. REGISTER INITIALIZATION AND ASIC ADDRESS ASSIGNMENTS**

REGISTER	HEX ADDR	INITIALIZED CONTENTS	DESCRIPTION/COMMENTS
<b>TOP</b>		0000 0000 0000 0000	Top Register
<b>NEXT</b>		1111 1111 1111 1111	Next Register
<b>IR</b>		0000 0000 0000 0000	Instruction Register
<b>I</b>	00H 01H 02H	1111 1111 1111 1111	Index Register
<b>CR</b>	03H	0100 0000 0000 1000	Configuration Register: Boot = 1; Interrupts Disabled; Byte Order = 0.
<b>MD</b>	04H	1111 1111 1111 1111	Multi-Step Divide Register
<b>SR</b>	06H	0000 0010 0000 0000	Square Root Register
<b>PC</b>	07H	0000 0000 0000 0000	Program Counter Register
<b>IMR</b>	08H	0000 0000 0000 0000	Interrupt Mask Register
<b>SPR</b>	09H	0000 0000 0000 0000	Stack Pointer Register: The beginning address for each stack is set to a value of '0'.
<b>SUR</b>	0AH	0000 0111 0000 0111	Stack Underflow Limit Register
<b>IVR</b>	0BH	0000 0010 0000 0000	Interrupt Vector Register: Read only; this register holds the current Interrupt Vector value, and is initialized to the "No Interrupt" value.
<b>SVR</b>	0BH	1111 1111 1111 1111	Stack Overflow Limit Register: Write-only; Each stack limit is set to its maximum value.
<b>IPR</b>	0CH	0000 0000 0000 0000	Index Page Register
<b>DPR</b>	0DH	0000 0000 0000 0000	Data Page Register: The Data Address Page is set for page '0'.
<b>UPR</b>	0EH	0000 0000 0000 0000	User Page Register: The User Address Page is set for page '0'.
<b>CPR</b>	0FH	0000 0000 0000 0000	Code Page Register: The Code Address Page is set for page '0'.
<b>IBC</b>	10H	0000 0000 0000 0000	Interrupt Base/Control Register
<b>UBR</b>	11H	0000 0000 0000 0000	User Base Address Register: The User base address is set to '0' within the User page.
<b>MXR</b>	12H	0000 0000 0000 0000	MAC Extension Register
<b>TC0 / TP0</b>	13H	0000 0000 0000 0000	Timer/Counter Register 0: Set to time out after 65536 clock periods or events.
<b>TC1 / TP1</b>	14H	0000 0000 0000 0000	Timer/Counter Register 1: Set to time out after 65536 clock periods or events.
<b>TC2 / TP2</b>	15H	0000 0000 0000 0000	Timer/Counter Register 2: Set to time out after 65536 clock periods or events.
<b>MLR</b>	16H	0000 0000 0000 0000	Multiplier Lower Product Register
<b>MHR</b>	17H	0000 0000 0000 0000	Multiplier High Product Register

### Dual Stack Architecture

The HS-RTX2010RH features a dual stack architecture. The two 256-word stacks are the Parameter Stack and the Return Stack, both of which may be accessed in parallel by a single instruction, and which minimize overhead in passing parameters between subroutines. The functional structure of each of these stacks is shown in Figure 14.

The Parameter Stack is used for temporary storage of data and for passing parameters between subroutines. The top two elements of this stack are contained in the **TOP** and **NEXT** registers of the processor, and the remainder of this stack is located in stack memory. The stack memory assigned to the Parameter Stack is 256 words deep by 16 bits wide.

The Return Stack is used for storing return addresses when performing Subroutine Calls, or for storing values temporarily. Because the HS-RTX2010RH uses a separate Return Stack, it can call and return from subroutines and interrupts with a minimum of overhead. The Return Stack is 21 bits wide. The 16-bit Index Register, **I**, and the 5-bit Index Page Register, **IPR**, hold the top element of this stack, while the remaining elements are located in stack memory. The stack memory portion of the Return Stack is 21 bits wide, by 256 words deep.

The data on the Return Stack takes on different meaning, depending upon whether the Return Stack is being used for temporary storage of data or to hold a return address during a subroutine operation (Figure 11).

### HS-RTX2010RH Stack Controllers

The two stacks of the HS-RTX2010RH are controlled by identical Programmable Stack Controllers.

The operation of the Programmable Stack Controllers depends on the contents of three registers. These registers are **SPR**, the Stack Pointer Register, **SVR**, the Stack Overflow Limit Register, and **SUR**, the Stack Underflow Limit Register (see Figures 7, 8, and 9).

**SPR** contains the address of the next stack memory location to be accessed in a stack push (write) operation. After a push, the **SPR** is incremented (post-increment operation). In a stack pop (read) operation, the stack memory location with an address one less than the **SPR** will be accessed, and then the **SPR** will be decremented (pre-decrement operation). At start-up, the first stack location to have data pushed into it is location zero.

Upper and lower limit values for the stacks are set into the Stack Overflow Limit Register and in the Stack Underflow Limit Register. These values allow interrupts to be generated prior to the occurrence of stack overflow or underflow error conditions (see section on Stack Error Conditions for more detail). Since the HS-RTX2010RH can take up to four clock cycles to respond to an interrupt, the values set in these registers should include a safety margin which allows valid stack operation until the processor executes the interrupt service routine.

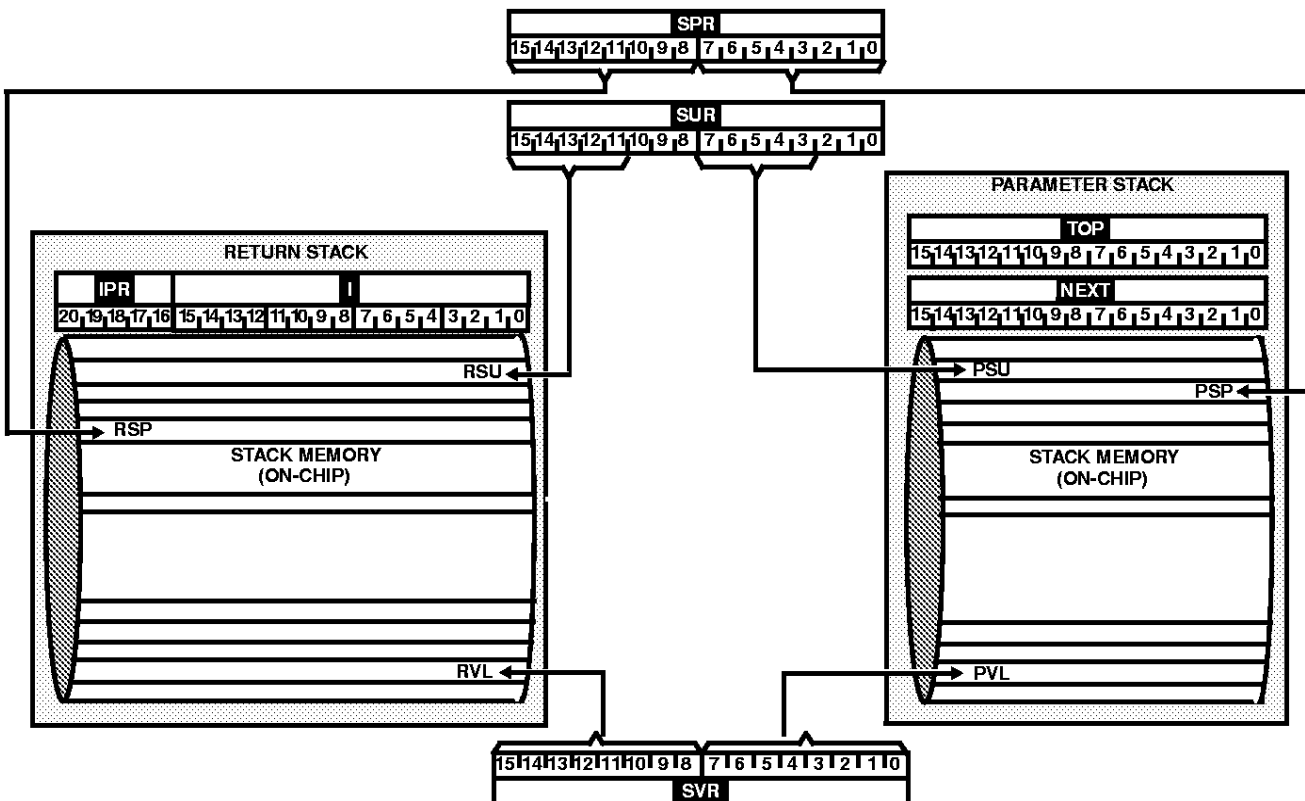

FIGURE 14. DUAL STACK ARCHITECTURE

## Substacks

Each 256-word stack may be subdivided into up to eight 32 word substacks, four 64 word substacks, or two 128 word substacks. This is accomplished under hardware control for simplified management of multiple tasks. Stack size is selected by writing to bits 1 and 2 of the **SUR** for the Parameter Stack, and bits 9 and 10 for the Return Stack.

Substacks are implemented by making bits 5-7 of the **SPR** (for the Parameter Stack) and bits 13-15 of the **SPR** (for the Return Stack) control bits. For example, if there were eight 32 word substacks implemented in the Parameter Stack, bits 5-7 of the **SPR** are not incremented, but instead are used as an offset pointer into the Parameter Stack to indicate the beginning point (i.e. sub stack number) of each 32 word substack implemented. Because of this, a particular substack is selected by writing a value which contains both the stack pointer value and the substack number to the **SPR**.

Each stack has a Stack Start Flag (PSF and RSF) which may be used for implementing virtual stacks. For the Parameter Stack, the Start Flag is bit zero of the **SUR**, and for the Return Stack it is bit eight. If the Stack Start Flag is one, the stack starts at the bottom of the stack or substack (location 0). If the Stack Start Flag is zero, the substack starts in the middle of the stack. An exception to this occurs if the overflow limit in **SVR** is set for a location below the middle of the stack. In this case, the stacks always start at the bottom locations. See Table 8 for the possible stack configurations. Manipulating the Stack Start Flag provides a mechanism for creating a virtual stack in memory which is maintained by interrupt driven handlers.

Possible applications for substacks include use as a recirculating buffer (to allow quick access for a series of repeated values such as coefficients for polynomial evaluation or a digital filter), or to log a continuous stream of data until a triggering event (for analysis of data before and after the trigger without having to store all of the incoming data). The latter application could be used in a digital oscilloscope or logic analyzer.

## Stack Error Conditions

Stack errors include overflow, underflow, and fatal errors. Overflows occur when an attempt is made to push data onto a full stack. Since the stacks wrap around, the result is that existing data on the stack will be overwritten by the new data when an overflow occurs. Underflows occur when an attempt is made to pop data off an empty stack, causing invalid data to be read from the stack. In both cases, a buffer zone may be set up by initializing **SVR** and **SUR** so that stack error interrupts are generated prior to an actual overflow or underflow. The limits may be determined from the contents of **SVR** and **SUR** using Table 8. The state of all stack errors may be determined by examining the five least significant bits of **IBC**, where the stack error flags may be read but not written to. All stack error flags are cleared whenever a new value is written to **SPR**.

**Fatal Stack Error:** Each stack can also experience a fatal stack error. This error condition occurs when an attempt is made to push data onto or to pop data off of the highest location of the substack. It does not generate an interrupt (since the normal stack limits can be used to generate the interrupt). The fatal errors for the stacks are logically OR'ed together to produce bit 0 of the Interrupt Base Control Register, and they are cleared whenever **SPR** is written to. The implication of a fatal error is that data on the stack may have been corrupted or that invalid data may have been read from the stack.

## HS-RTX2010RH Timer/Counters

The HS-RTX2010RH has three 16-bit timers, each of which can be configured to perform timing or event counting. All decrement synchronously with the rising edge of TCLK. Timer registers are readable in a single machine cycle.

The timer selection bits of the **IBC** determine whether a timer is to be configured for external event counting or internal time-base timing. This configures the respective counter clock inputs to the on-chip TCLK signal for internal timing, or to the EI5 - EI3 input pins for external signal event counting. EI5, EI4, and EI3 are synchronized internally with TCLK. See Table 9 for Timer/Clock selection by **IBC** bit values.

The timers (**TC0**, **TC1** and **TC2**) are all free-running, and when they time out, they reload automatically with the programmed initial value from their respective Timer Pre load Registers (**TPO** → **TC0**, **TP1** → **TC1**, and **TP2** → **TC2**), then continue timing or counting.

Each timer provides an output to the Interrupt Controller to indicate when a time-out for the timer has occurred.

The HS-RTX2010RH can determine the state of a timer at any time either by reading the timer's value, or upon a time-out by using the timer's interrupt (see the Interrupt Controller section for more information about how timer interrupts are handled). Figure 15 shows the sequence of Timer/Counter operations.

TABLE 8. STACK/SUBSTACK CONFIGURATIONS FOR GIVEN CONTROL BIT SETTINGS

CONTROL BIT SETTINGS										PARAMETER STACK CONFIGURATION													
SVR				SUR			STACK SIZE WORDS	LOWEST ADDRESS							HIGHEST ADDRESS								
V7	V6	V5	V4	U2	U1	U0		7	6	5	4	3	2	1	0	7	6	5	4	3	2	1	0
X	X	X	0	0	0	X	32	P7	P6	P5	0	0	0	0	0	P7	P6	P5	1	1	1	1	1
X	X	X	1	0	0	0	32	P7	P6	P5	0	0	0	0	0	P7	P6	P5	1	1	1	1	1
X	X	X	1	0	0	1	32	P7	P6	P5	0	0	0	0	0	P7	P6	P5	1	1	1	1	1
X	X	0	X	0	1	X	64	P7	P6	0	0	0	0	0	0	P7	P6	1	1	1	1	1	1
X	X	1	X	0	1	0	64	P7	P6	0	0	0	0	0	0	P7	P6	1	1	1	1	1	1
X	X	1	X	0	1	1	64	P7	P6	0	0	0	0	0	0	P7	P6	1	1	1	1	1	1
X	0	X	X	1	0	X	128	P7	0	0	0	0	0	0	0	P7	1	1	1	1	1	1	1
X	1	X	X	1	0	0	128	P7	0	0	0	0	0	0	0	P7	1	1	1	1	1	1	1
X	1	X	X	1	0	1	128	P7	0	0	0	0	0	0	0	P7	1	1	1	1	1	1	1
0	X	X	X	1	1	X	256	0	0	0	0	0	0	0	1	1	1	1	1	1	1	1	1
1	X	X	X	1	1	0	256	0	0	0	0	0	0	0	1	1	1	1	1	1	1	1	1
1	X	X	X	1	1	1	256	0	0	0	0	0	0	0	1	1	1	1	1	1	1	1	1
CONTROL BIT SETTINGS										RETURN STACK CONFIGURATION													
SVR				SUR			STACK SIZE WORDS	LOWEST ADDRESS							HIGHEST ADDRESS								
V15	V14	V13	V12	U10	U9	U8		7	6	5	4	3	2	1	0	7	6	5	4	3	2	1	0
X	X	X	0	0	0	X	32	P15	P14	P13	0	0	0	0	0	P15	P14	P13	1	1	1	1	1
X	X	X	1	0	0	0	32	P15	P14	P13	0	0	0	0	0	P15	P14	P13	1	1	1	1	1
X	X	X	1	0	0	1	32	P15	P14	P13	0	0	0	0	0	P15	P14	P13	1	1	1	1	1
X	X	0	X	0	1	X	64	P15	P14	0	0	0	0	0	0	P15	P14	1	1	1	1	1	1
X	X	1	X	0	1	0	64	P15	P14	0	0	0	0	0	0	P15	P14	1	1	1	1	1	1
X	X	1	X	0	1	1	64	P15	P14	0	0	0	0	0	0	P15	P14	1	1	1	1	1	1
X	0	X	X	1	0	X	128	P15	0	0	0	0	0	0	0	P15	1	1	1	1	1	1	1
X	1	X	X	1	0	0	128	P15	0	0	0	0	0	0	0	P15	1	1	1	1	1	1	1
X	1	X	X	1	0	1	128	P15	0	0	0	0	0	0	0	P15	1	1	1	1	1	1	1
0	X	X	X	1	1	X	256	0	0	0	0	0	0	0	1	1	1	1	1	1	1	1	1
1	X	X	X	1	1	0	256	0	0	0	0	0	0	0	1	1	1	1	1	1	1	1	1
1	X	X	X	1	1	1	256	0	0	0	0	0	0	0	1	1	1	1	1	1	1	1	1

TABLE 8. STACK/SUBSTACK CONFIGURATIONS FOR GIVEN CONTROL BIT SETTINGS (Continued)

CONTROL BIT SETTINGS														PARAMETER STACK CONFIGURATION																											
SVR							SUR							FATAL LIMIT							UNDERFLOW LIMIT							OVERFLOW LIMIT													
V7	V6	V5	V4	U2	U1	U0	U7	U6	U5	U4	U3	U2	U1	U0	P7	P6	P5	P4	P3	P2	P1	P0	U7	U6	U5	U4	U3	U2	U1	U0	P7	P6	P5	P4	P3	P2	P1	P0			
X	X	X	0	0	0	X	P7	P6	P5	1	1	1	1	1	P7	P6	P5	0	U6	U5	U4	U3	U2	U1	U0	P7	P6	P5	0	V3	V2	V1	V0								
X	X	X	1	0	0	0	P7	P6	P5	0	1	1	1	1	P7	P6	P5	1	U6	U5	U4	U3	U2	U1	U0	P7	P6	P5	0	V3	V2	V1	V0								
X	X	X	1	0	0	1	P7	P6	P5	1	1	1	1	1	P7	P6	P5	0	U6	U5	U4	U3	U2	U1	U0	P7	P6	P5	1	V3	V2	V1	V0								
X	X	0	X	0	1	X	P7	P6	1	1	1	1	1	1	P7	P6	0	U7	U6	U5	U4	U3	U2	U1	U0	P7	P6	0	V4	V3	V2	V1	V0								
X	X	1	X	0	1	0	P7	P6	0	1	1	1	1	1	P7	P6	1	U7	U6	U5	U4	U3	U2	U1	U0	P7	P6	0	V4	V3	V2	V1	V0								
X	X	1	X	0	1	1	P7	P6	1	1	1	1	1	1	P7	P6	0	U7	U6	U5	U4	U3	U2	U1	U0	P7	P6	1	V4	V3	V2	V1	V0								
X	0	X	X	1	0	X	P7	1	1	1	1	1	1	1	P7	0	0	U7	U6	U5	U4	U3	U2	U1	U0	P7	0	V5	V4	V3	V2	V1	V0								
X	1	X	X	1	0	0	P7	0	1	1	1	1	1	1	P7	1	0	U7	U6	U5	U4	U3	U2	U1	U0	P7	0	V5	V4	V3	V2	V1	V0								
X	1	X	X	1	1	0	P7	1	1	1	1	1	1	1	P7	0	0	U7	U6	U5	U4	U3	U2	U1	U0	P7	1	V5	V4	V3	V2	V1	V0								
0	X	X	X	1	1	X	1	1	1	1	1	1	1	1	0	0	0	U7	U6	U5	U4	U3	U2	U1	U0	0	V6	V5	V4	V3	V2	V1	V0								
1	X	X	X	1	1	0	0	1	1	1	1	1	1	1	1	0	0	U7	U6	U5	U4	U3	U2	U1	U0	0	V6	V5	V4	V3	V2	V1	V0								
1	X	X	X	1	1	1	1	1	1	1	1	1	1	1	0	0	0	U7	U6	U5	U4	U3	U2	U1	U0	0	V6	V5	V4	V3	V2	V1	V0								

CONTROL BIT SETTINGS														PARAMETER STACK CONFIGURATION																											
SVR							FATAL LIMIT							UNDERFLOW LIMIT							OVERFLOW LIMIT																				
V15	V14	V13	V12	U10	U9	U8	P15	P14	P13	P12	P11	P10	P9	P8	U15	U14	U13	U12	U11	U10	U9	U8	U7	U6	U5	U4	U3	U2	U1	U0	P15	P14	P13	P12	P11	P10	P9	P8			
X	X	X	0	0	0	X	P15	P14	P13	1	1	1	1	1	P15	P14	P13	0	U14	U13	U12	U11	U10	U9	U8	U7	U6	U5	U4	U3	U2	U1	U0	P15	P14	P13	0	V11	V10	V9	V8
X	X	X	1	0	0	0	P15	P14	P13	0	1	1	1	1	P15	P14	P13	1	U14	U13	U12	U11	U10	U9	U8	U7	U6	U5	U4	U3	U2	U1	U0	P15	P14	P13	0	V11	V10	V9	V8
X	X	X	1	0	0	1	P15	P14	P13	1	1	1	1	1	P15	P14	P13	0	U14	U13	U12	U11	U10	U9	U8	U7	U6	U5	U4	U3	U2	U1	U0	P15	P14	P13	1	V11	V10	V9	V8
X	X	0	X	0	1	X	P15	P14	1	1	1	1	1	1	P15	P14	0	U15	U14	U13	U12	U11	U10	U9	U8	U7	U6	U5	U4	U3	U2	U1	U0	P15	P14	0	V12	V11	V10	V9	V8
X	X	1	X	0	1	0	P15	P14	0	1	1	1	1	1	P15	P14	1	U15	U14	U13	U12	U11	U10	U9	U8	U7	U6	U5	U4	U3	U2	U1	U0	P15	P14	0	V12	V11	V10	V9	V8
X	X	1	X	0	1	1	P15	P14	1	1	1	1	1	1	P15	P14	0	U15	U14	U13	U12	U11	U10	U9	U8	U7	U6	U5	U4	U3	U2	U1	U0	P15	P14	1	V12	V11	V10	V9	V8

TABLE 8. STACK/SUBSTACK CONFIGURATIONS FOR GIVEN CONTROL BIT SETTINGS (Continued)

CONTROL BIT SETTING											PARAMETER STACK CONFIGURATION																				
SVR						SUR					FATAL LIMIT							UNDERFLOW LIMIT							OVERFLOW LIMIT						
V15	V14	V13	V12	U10	U9	U8	7	6	5	4	3	2	1	0	7	6	5	4	3	2	1	0	7	6	5	4	3	2	1	0	
X	0	X	X	1	0	X	P15	1	1	1	1	1	1	1	P15	0	0	U15	U14	U13	U12	U11	P15	0	V13	V12	V11	V10	V9	V8	
X	1	X	X	1	0	0	P15	0	1	1	1	1	1	1	P15	1	0	U15	U14	U13	U12	U11	P15	0	V13	V12	V11	V10	V9	V8	
X	1	X	X	1	0	1	P15	1	1	1	1	1	1	1	P15	0	0	U15	U14	U13	U12	U11	P15	1	V13	V12	V11	V10	V9	V8	
0	X	X	X	1	1	X	1	1	1	1	1	1	1	1	0	0	0	U15	U14	U13	U12	U11	0	V14	V12	V11	V10	V9	V8		
1	X	X	X	1	1	0	0	1	1	1	1	1	1	1	1	0	0	U15	U14	U13	U12	U11	0	V14	V12	V11	V10	V9	V8		
1	X	X	X	1	1	1	1	1	1	1	1	1	1	1	0	0	0	U15	U14	U13	U12	U11	1	V14	V12	V11	V10	V9	V8		

NOTES:

1. **SPR**: Stack Pointer Register; **SVR**: Stack Overflow Register; **SUR**: Stack Underflow Register
2. P0 . . P15: **SPR** Bits, V0 . . V15: **SVR** Bits, U0 . . U15: **SUR** Bits
3. The Overflow Limit is the stack memory address at which an overflow condition will occur during a stack write operation.
4. The Underflow Limit is the stack memory address below which an underflow condition will occur during a stack read operation.
5. The Fatal Limit is the stack memory address at which a fatal error condition will occur during a stack read or write operation.
6. Stack error conditions remain in effect until a new value is written to the **SPR**.
7. Stacks and sub-stacks are circular: after writing to the highest location in the stack, the next location to be written to will be the lowest location; after reading the lowest location, the highest location will be read next.



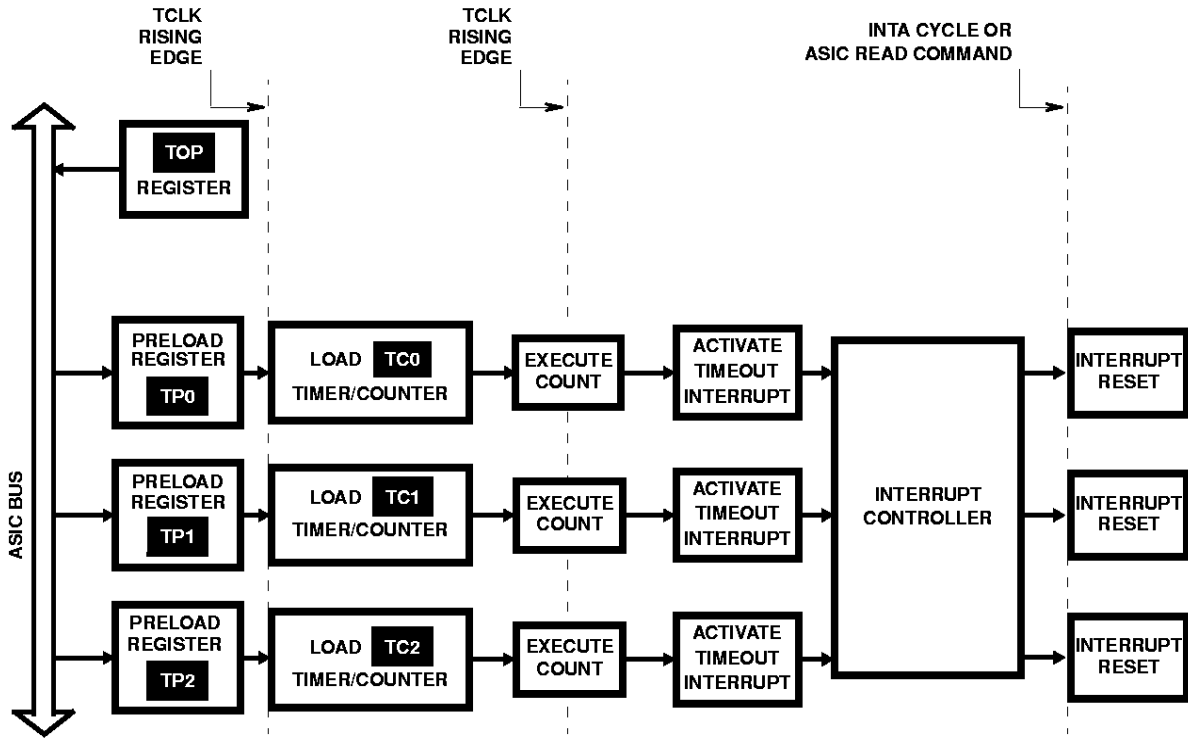

FIGURE 15. HS-RTX2010RH TIMER/COUNTER OPERATION

TABLE 9. TIMER/COUNTER

IBC BIT VALUES		TIMER CLOCK SOURCE		
BIT 09	BIT 08	TC2	TC1	TC0
0	0	TCLK	TCLK	TCLK
0	1	TCLK	TCLK	EI3
1	0	TCLK	EI4	EI3
1	1	EI5	EI4	EI3

**HS-RTX2010RH Interrupt Controller**

The HS-RTX2010RH Interrupt Controller manages interrupts for the HS-RTX2010RH Microcontroller core. Its sources include two on-chip peripherals and six external interrupt inputs. The two classes of on-chip peripherals that produce interrupts are the Stack Controllers and the Timer/Counters.

**Interrupt Controller Operation**

When one of the interrupt sources requests an interrupt, the Interrupt Controller checks whether the interrupt is masked in the Interrupt Mask Register. If it is not, the controller attempts to interrupt the processor. If processor interrupts are enabled (bit 4 of the Configuration Register), the processor will execute an Interrupt Acknowledge cycle, during which it disables interrupts to ensure proper completion of the INTA cycle.

In response to the Interrupt Acknowledge cycle, the Interrupt Controller places an Interrupt Vector on the internal ASIC Bus, based on the highest priority pending interrupt. The processor performs a special Subroutine Call to the address in Memory Page 0 contained in the vector. This special subroutine call is different in that it saves a status bit on the Return Stack indicating the call was caused by an interrupt. Thus, when the Interrupt Handler executes a Subroutine Return, the processor knows to automatically re-enable interrupts. Before the Interrupt Handler returns, it must ensure that the condition that caused the interrupt is cleared. Otherwise the processor will again be interrupted immediately upon its return.

Processor interrupts are enabled and disabled by clearing and setting the Interrupt Disable Flag. When the RTX is reset, this flag is set (bit 04 of the **CR** = 1), disabling the interrupts. This bit is a write-only bit that always reads as 0, allowing interrupts

to be enabled in only 2 cycles with a simple read/write operation in which the processor reads the bit value, then writes it back to the same location. The actual status of the Interrupt Disable Flag can be read from bit 14 of **CR**.

During read and write operations to the Configuration Register, (**CR**), interrupts are inhibited to allow the program to save and restore the state of the Interrupt Enable bit.

In addition to disabling interrupts at the processor level, all interrupts except the Non-Maskable Interrupt (NMI) can be individually masked by the Interrupt Controller by setting the appropriate bit in the Interrupt Mask Register (**IMR**). Resetting the HS-RTX2010RH causes all bits in the **IMR** to be cleared, thereby unmasking all interrupts.

The NMI on the HS-RTX2010RH has two modes of operation which are controlled by the NMI\_MODE Flag (bit 11 of the **CR**). When this bit is cleared (0), the NMI can not be masked, and can interrupt any cycle. This allows a fast response to the NMI, but may not allow a return from interrupt to operate correctly. NMI\_MODE is cleared when the processor is Reset. When NMI\_MODE is set (1), a return from the NMI service routine will result in the processor continuing execution in the state it was in when it was interrupted. When in this second mode NMI may be inhibited by the processor during certain critical operations (see Interrupt Suppression), and may, therefore, not be serviced as quickly as in the first mode of operation. When servicing an NMI\_MODE set to 1, further NMIs and maskable interrupts are disabled until the NMI Interrupt Service Routine has completed, and a return from interrupt has been executed.

**TABLE 10. INTERRUPT SOURCES, PRIORITIES AND VECTORS**

PRIORITY	INTERRUPT SOURCE		SENSITIVITY	IMR BIT	VECTOR ADDRESS BITS				
					09	08	07	06	05
0 (High)	NMI	Non-Maskable Interrupt	Pos Edge	N/A	0	1	1	1	1
1	EI1	External Interrupt 1	High Level	01	0	1	1	1	0
2	PSU	Parameter Stack Underflow	High Level	02	0	1	1	0	1
3	RSU	Return Stack Underflow	High Level	03	0	1	1	0	0
4	PSV	Parameter Stack Overflow	High Level	04	0	1	0	1	1
5	RSV	Return Stack Overflow	High Level	05	0	1	0	1	0
6	EI2	External Interrupt 2	High Level	06	0	1	0	0	1
7	TCI0	Timer/Counter 0	Edge	07	0	1	0	0	0
8	TCI1	Timer/Counter 1	Edge	08	0	0	1	1	1
9	TCI2	Timer/Counter 2	Edge	09	0	0	1	1	0
10	EI3	External Interrupt 3	High Level	10	0	0	1	0	1
11	EI4	External Interrupt 4	High Level	11	0	0	1	0	0
12	EI5	External Interrupt 5	High Level	12	0	0	0	1	1
13 (Low)	SWI	Software Interrupt	High Level	13	0	0	0	1	0
N/A	None	No Interrupt	N/A	N/A	1	0	0	0	0

The Interrupt Controller prioritizes interrupt requests and generates an Interrupt Vector for the highest priority interrupt request. The address that the vector points to is determined by the source of the interrupt and the contents of the Interrupt Base/Control Register (**IBC**). See Figure 4 for the Interrupt Vector Register bit assignments. Because address bits MA19-MA16 are always zero in an Interrupt Acknowledge cycle, the entry point to the Interrupt Handlers must reside on Memory Page zero.

Because address bits MA04-MA01 are always zero in an Interrupt Acknowledge cycle, Interrupt Vectors are 32 bytes apart. This means that Interrupt Handler routines that are 32 bytes or less can be compiled directly into the Interrupt Table. Interrupt Handlers greater than 32 bytes must be compiled separately and called from the Interrupt Table.

The rest of the vector is generated as indicated in Table 7. To guarantee that the Interrupt Vector will be stable during an INTA cycle, the Interrupt Controller inhibits the generation of a new Interrupt Vector while INTA is high, and will not begin generating a new Interrupt Vector on either edge of INTA.

The Interrupt Vector can also be read from the Interrupt Vector Register (**IVR**) directly. This allows interrupt requests to be monitored by software, even if they are disabled by the processor. If no interrupts are being requested, bit 09 of the **IVR** will be 1.

External interrupts EI5-EI1 are active HIGH level-sensitive inputs. (Note: When used as Timer/Counter inputs, EI5-EI3 are edge sensitive). Therefore, the Interrupt Handlers for these interrupts must clear the source of interrupt prior to returning to the interrupted code. The external NMI, however, is an edge-sensitive input which requires a rising edge to request an interrupt. The NMI input also has a glitch filter circuit which requires that the signal that initiates the NMI must last at least two rising and two falling edges of ICLK.

Finally, a mechanism is provided by which an interrupt can be requested by using a software command. The Software Interrupt (SWI) is requested by executing an instruction that will set an internal flip-flop attached to one input of the Interrupt Controller. The SWI is reset by executing an instruction that clears the flip-flop. The flip-flop is accessed by I/O Reads and Writes.

Because the SWI interrupt may not be serviced immediately, the instructions which immediately follow the SWI instruction should not depend on whether or not the interrupt has been serviced, and should cause a one or two-cycle idle condition (Typically, this is done with one or two NOP instructions).

If an interrupt condition occurs, but “goes away” before the processor has a chance to service it, a “No Interrupt” vector is generated. A “No Interrupt” vector is also generated if an Interrupt Acknowledge cycle takes less than two cycles to execute and no other interrupt conditions need to be serviced.

To prevent unforeseen errors, it is recommended that valid code be supplied at every Interrupt Vector location, including the “No Interrupt” vector, which should always be initialized with valid code.

It is recommended that Interrupt Handlers save and restore the contents of **CR**.

## Interrupt Suppression

The HS-RTX2010RH allows maskable interrupts and Mode 1 NMIs (the NMI\_MODE Flag in bit 11 of the **CR** is set) to be suppressed, delaying them temporarily while critical operations are in progress. Critical operations are instruction sequences and hardware operations that, if interrupted, would result in the loss of data or misoperation of the hardware. (Note: Only the processor may suppress NMIs).

Standard critical operations during which interrupts are automatically suppressed by the processor include Streamed instructions (see the description of the **I** register), Long Call sequences (see “Subroutine Calls and Returns”), and loading **CR**. In addition to this, external devices can also suppress maskable interrupts during critical operations by applying a HIGH level on the INTSUP pin for as long as required.

Since the Mode 0 NMI (the NMI\_MODE Flag in bit 11 of the **CR** is cleared) can cause the processor to perform an Interrupt Acknowledge Cycle in the middle of these critical operations, thereby preventing a normal return to the interrupted instruction, a Subroutine Return should be used with care from a Mode 0 NMI service routine. The Mode 0 NMI should be used only to indicate critical system errors, and the Mode 0 NMI handler should re-initialize the system.

Interrupts which have occurred while interrupt suppression is in effect will be recognized on a priority basis as soon as the suppression terminates, provided the condition which generated the interrupt still exists.

## Stack Error Interrupts

The Stack Controllers request an interrupt whenever a stack overflow or underflow condition exists. These interrupts can be cleared by rewriting **SPR**. See the section on “Dual Stack Architecture” for more information regarding how the limits set into **IBC** and **SUR** are used.

**Stack Overflow:** A stack overflow occurs when data is pushed onto the stack location pointed to by the **SVR**, as determined in Table 5. After the processor is reset, this is location 255 in either the Parameter Stack or Return Stack. A stack overflow interrupt request stays in effect until cleared by writing a new value to the **SPR**. In addition to generating an interrupt, the state of the stack overflow flags may be read out of the **IBC**, bit 3 for the Parameter Stack, and bit 4 for the Return stack. See Figures 5, 7 and 8.

**Stack Underflow:** The stack underflow limit occurs when data is popped off the stack location immediately below that pointed to by the **SUR**, as determined in Table 8. The state of the stack underflow error flags may be read out of bits 1 and 2 of the **IBC** for the Parameter and Return stacks respectively. In the reset state of the **SUR**, an underflow will be generated at the same time that a fatal error is detected. An underflow buffer region can be set up by selecting an underflow limit greater than zero by writing the corresponding value into the **SUR**. The stack underflow interrupt request stays in effect until a new value is written into the **SPR**, at which time it is cleared.

**Timer/Counter Interrupts**

The timers generate edge-sensitive interrupts whenever they are decremented to 0. Because they are edge-sensitive and are cleared during an Interrupt Acknowledge cycle or during the direct reading of **IVR** by software, no action is required by the handlers to clear the interrupt request.

**The HS-RTX2010RH ALU**

The HS-RTX2010RH has a 16-bit ALU capable of performing standard arithmetic and logic operations:

- ADD and SUBTRACT (A-B and B-A; with and without carry)
- AND, OR, XOR, NOR, NAND, XNOR, NOT

The **TOP** and **NEXT** registers can also undergo single bit shifts in the same cycle as a logic or arithmetic operation.

In Figure 16, the control and data paths to the ALU are shown. Except for **TOP** and **NEXT**, each of the internal core registers can be addressed explicitly, as can other internal registers in special operations such as in Step instructions. In each of these cases, the input would be addressed as a device on the ASIC Bus.

When executing these instructions, the arithmetic/logic operand (a) starts out in **TOP** and is placed on the T-bus. Operand (b) arrives at the ALU on the Y-bus, but can come from one of the following four sources: **NEXT**; an internal register; an ASIC Bus device; or from the 5 least significant bits of **IR**. The source of operand (b) is determined by the instruction code in **IR**. The result of the ALU operation is placed into **TOP**.

Step Arithmetic instructions which are performed through the ALU are divide and square root. Execution of each step of the arithmetic operation takes one cycle, a 32/16-bit Step Divide takes 21 cycles, and a 32/16-bit Step Square Root takes 25 cycles. Sign and scaling functions are controlled by the ALU function and shift options, which are part of the coded instruction contained in **IR**. See Table 26 and Tabel 27 and the Programmer's Reference Manual for details.

Unsigned Step Divide operation assumes a double precision (32-bit) dividend, with the most significant word placed in **TOP**, the less significant word in **NEXT**, and the divisor in **MD**. In each step, if the contents in **TOP** are equal to or greater than the contents in **MD** (and therefore no borrow is generated), then the contents of **MD** are subtracted from the contents of **TOP**. The result of the subtraction is placed into **TOP**. The contents of **TOP** and **NEXT** are then jointly shifted left one bit (32-bit left shift), where the value shifted into the least significant bit of **NEXT** is the value of the Borrow bit on the first pass, or the value of the Complex Carry bit on each of the subsequent passes. On the 15th and final pass, only **NEXT** is shifted left, receiving the value of the Complex Carry bit into the LSB. **TOP** is not shifted. The final result leaves the quotient in **NEXT**, and the remainder in **TOP**.

During a Step Square Root operation, the 32-bit argument is assumed to be in **TOP** and **NEXT**, as in the Step Divide operation. The first step begins with **MD** containing zeros. The Step Square Root is performed much like the Step Divide, except that the input from the Y-bus is the logical OR of the contents of **SR** and the value in **MD** shifted one place to the left ( $2 * MD$ ). When the subtraction is performed, **SR** is OR'ed into **MD**, and **SR** is shifted one place to the right. At the end of the operation, the square root of the original value is in **MD** and **NEXT**, and the remainder is in **TOP**.

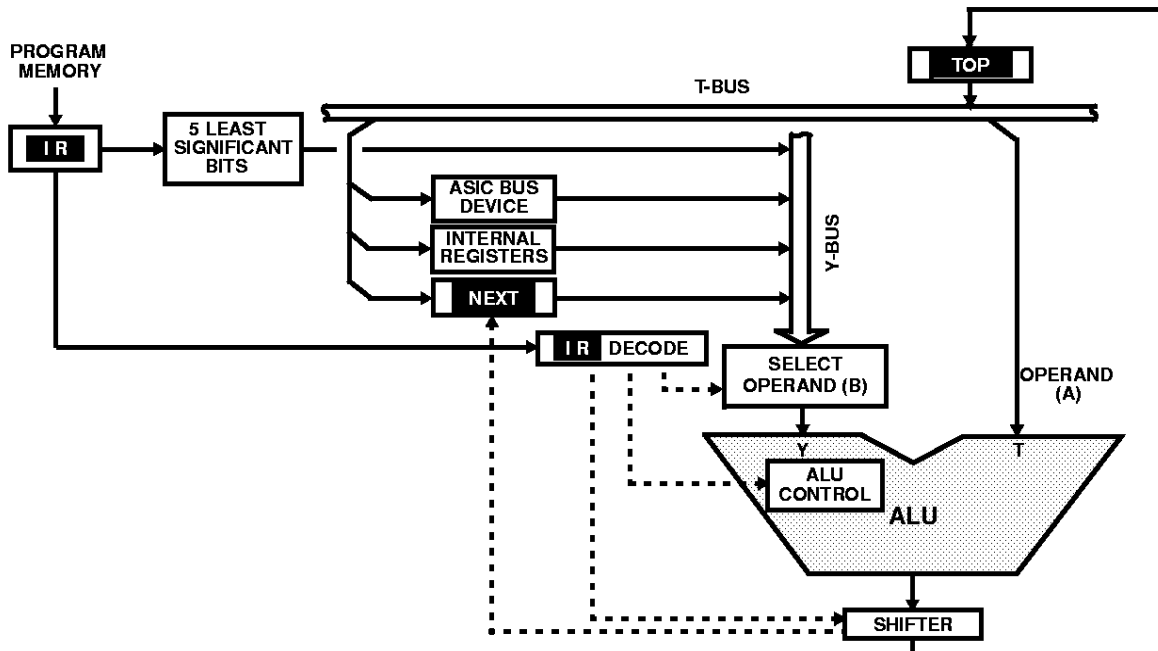

NOTE: Data Paths are represented by solid lines; Control Paths are represented by dashed lines.

FIGURE 16. ALU OPERATIONS-CONTROL PATHS AND DATA FLOW

**HS-RTX2010RH Floating Point/DSP On Chip Peripherals**

**The HS-RTX2010RH Multiplier-Accumulator**

The Hardware Multiplier-Accumulator (MAC) on the HS-RTX2010RH functions as both a Multiplier, and a Multiplier-Accumulator. When used as a Multiplier alone, it multiplies two 16-bit numbers, yielding a 32-bit product in one clock cycle. When used as a Multiplier-Accumulator, it multiplies two 16-bit numbers, yielding an intermediate 32-bit product, which is then added to the 48-bit Accumulator. This entire process takes place in a single clock cycle.

The Multiplier-Accumulator functions are activated by I/O Read and Write instructions to ASIC Bus addresses assigned to the MAC.

The MAC's input operands come from three possible sources (see Figure 17):

- (1) The **TOP** and **NEXT** registers.
- (2) The Parameter (Data) Stack and memory via **NEXT** (Streamed mode only - see the Programmer's Reference Manual).
- (3) Memory via **NEXT** and an input from the ASIC Bus (Streamed mode only - see the Programmer's Reference Manual).

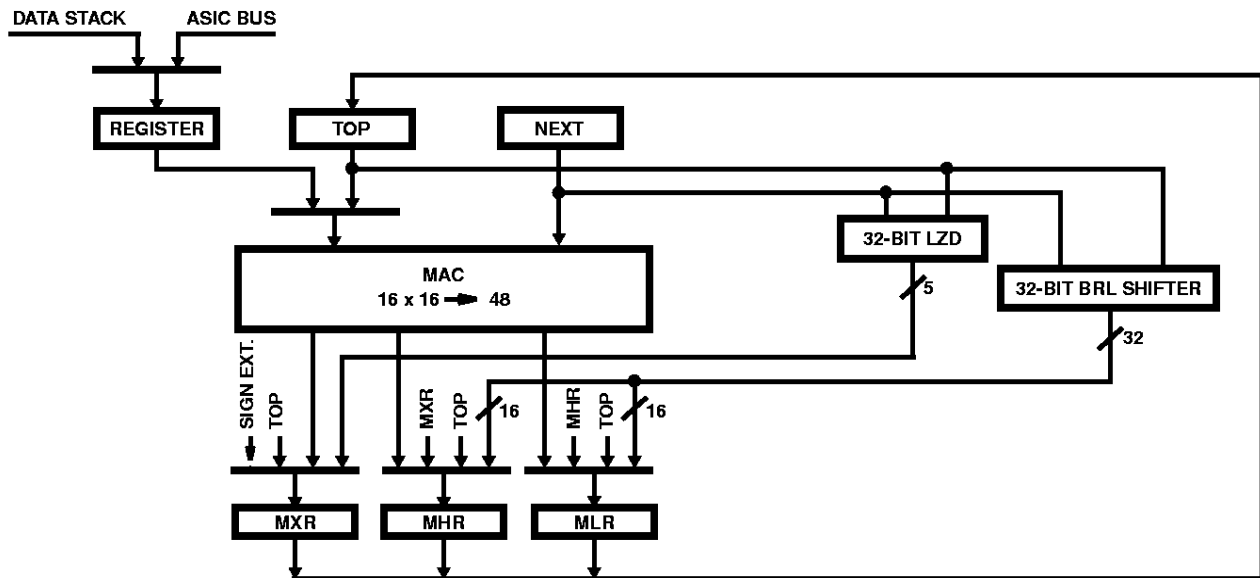

FIGURE 17. HS-RTX2010RH FLOATING POINT/DSP LOGIC

These inputs can be treated as either signed (two's complement) or unsigned integers, depending on the form of the instruction used. In addition, if the ROUND option is selected, the Multiplier can round the result to 16 bits. Note that the MAC instructions do not pop the Parameter Stack; the contents of **TOP** and **NEXT** remain intact.

For the Multiplier, the product is read from the Multiplier High Product Register, **MHR**, which contains the upper 16 bits of the product, and the Multiplier Low Product Register, **MLR**, which contains the lower 16 bits. For the Multiplier-Accumulator, the accumulated product is read from the Multiplier Extension Register, **MXR**, which contains the upper 16 bits, the **MHR**, which contains the middle 16 bits, and the **MLR**, which contains the low 16 bits. The registers may be read in any order, and there is no requirement that all registers be read. Reading from any of the three registers moves its value into **TOP**, and pushes the original value in **TOP** into **NEXT**. If the read is from **MHR** or **MLR**, the original value of **NEXT** is lost, i.e. it is not pushed onto stack memory. This permits overwriting the original operands left in **TOP** and **NEXT**, which are not popped by the MAC operations. If the read is from **MXR**, the original value of **NEXT** is pushed onto the stack. In addition to this, any of the three MAC registers can be directly loaded from **TOP**. This pops **NEXT** into **TOP** and the Parameter Stack into **NEXT**.

If 32-bit precision is not required, the multiplier output may be rounded to 16 bits. This is accomplished by setting the ROUND bit in the Interrupt Base/Control Register, **IBC**, to 1. If the ROUND bit is set to 1, all operations that use the Multiplier automatically round the least significant 16 bits of the result into the most significant 16 bits. The rounding is achieved by adding 8000H to the least significant 16 bits (during the same cycle as the multiply). Thus, if the ROUND bit is set:

- (1) If the most significant bit of the **MLR** is set (1), the **MHR** is incremented.
- (2) If the most significant bit of the **MLR** is not set (0), the **MHR** is left unchanged.

The ROUND bit functions independently of whether the signed or unsigned bit is used.

The multiply instructions suppress interrupts during the multiplication cycle. Reading **MHR**, or **MLR** also suppresses interrupts during the read. This allows a multiplication operation to be performed, and both the upper and lower registers to be read sequentially, with no danger of a non-NMI interrupt service routine corrupting the contents of the registers between reads. The multiply-accumulate instructions do not suppress interrupts during instruction execution.

For additional information on the HS-RTX2010RH MAC see the Programmer's Reference Manual.

**The HS-RTX2010RH On-Chip Barrel Shifter And Leading Zero Detector**

The HS-RTX2010RH has both a 32-bit Barrel Shifter and a 32-bit Leading Zero Detector for added floating-point and DSP performance. The inputs to the Barrel Shifter and Leading Zero Detector are the top two elements of the Parameter Stack, the **TOP** and **NEXT** registers.

The Barrel Shifter uses a 5-bit count stored in the **MXR** Register to determine the number of places to right or left shift the double word operand contained in the **TOP** and **NEXT** registers. The output of the Barrel Shifter is stored in the **MHR** and **MLR** registers, with the top 16 bits in **MHR** and the bottom 16 bits in **MLR**.

The Leading Zero Detector is used to normalize the double word operand contained in the **TOP** and **NEXT** registers. The number of leading zeroes in the double word operand are counted, and the count stored in the **MXR** register. The double word operand is then logically shifted left by this count, and the result stored in the **MHR** and **MLR** registers. Again the upper 16 bits are in **MHR**, and the lower 16 bits are in **MLR**. This entire operation is done in one clock cycle with the normalize instruction.

**HS-RTX2010RH ASIC Bus Interface**

The HS-RTX2010RH ASIC Bus services both internal processor core registers and the on-chip peripheral registers, and eight external off-chip ASIC Bus locations. All ASIC Bus operations require a single cycle to execute and transfer a full 16-bit word of data. The external ASIC Bus maps into the last eight locations of the 32 location ASIC Address Space. The three least significant bits of the address are available as the ASIC Address Bus. The addresses therefore map as shown in Table 11.

TABLE 11. ASIC BUS MAP

ASIC BUS SIGNAL			ASIC ADDRESS
GA02	GA01	GA00	
0	0	0	18H
0	0	1	19H
0	1	0	1AH
0	1	1	1BH
1	0	0	1CH
1	0	1	1DH
1	1	0	1EH
1	1	1	1FH

## HS-RTX2010RH Extended Cycle Operation

The HS-RTX2010RH bus cycle operation can be optionally extended for two types of accesses:

- (1) USER Memory Cycles
- (2) ASIC Bus Read Operations

The extension of normal HS-RTX2010RH bus cycle timing allows the interface of the processor to some peripherals, and slow memory devices, without using externally generated wait states. The bus cycle is extended by the same amount (1 TCLK) as it would be if one wait state was added to the cycle, but the control signal timing is somewhat different (see Timing Diagrams). In a one wait state bus cycle, PCLK is High for 1/2 TCLK period, and Low for 1-1/2 TCLK periods (i.e. PCLK is held Low for one additional TCLK period). In an extended cycle, PCLK is High for 1 TCLK period, and Low for 1 TCLK period (i.e. both the High and Low portions of the PCLK period are extended by 1/2 TCLK period).

Setting the Cycle Extend bit (CYCEXT), which is bit 7 of the **IBC** Register, will cause extended cycles to be used for all accesses to USER memory. Setting the ASIC Read Cycle Extend bit (ARCE), which is bit 13 of the **CR** Register, will cause extended cycles to be used for all Read accesses on the external ASIC Bus. Both the CYCEXT bit and the ARCE bit are cleared on Reset.

## HS-RTX2010RH Memory Access

### The HS-RTX2010RH Memory Bus Interface

The HS-RTX2010RH can address 1 Megabyte of memory, divided into 16 non-overlapping pages of 64K bytes. The memory page accessed depends on whether the memory access is for Code (instructions and literals), Data, User Memory, or Interrupt Code. The page selected also depends on the contents of the Page Control Registers: the Code Page Register (**CPR**), the Data Page Register (**DPR**), the User Page Register (**UPR**), and the Index Page Register (**IPR**). Furthermore, the User Base Address Register (**UBR**) and the Interrupt Base/Control Register (**IBC**) are used to determine the complete address for User Memory accesses and Interrupt Acknowledge cycles. External memory data is accessed through **NEXT**.

When executing code other than an Interrupt Service routine, the memory page is determined by the contents of the **CPR**. Bits 03-00 generate address bits MA19-MA16, as

shown in Figure 10. The remainder of the address (MA15-MA01) comes from the Program Counter Register (**PC**). After resetting the processor, both the **PC** and the **CPR** are cleared and execution begins at page 0, word 0.

A new Code page is selected by writing a 4-bit value to the **CPR**. The value for the Code page is input to the **CPR** through a preload procedure which withholds the value for one clock cycle before loading the **CPR** to ensure that the next instruction is executed from the same Code page as the instruction which set the new Code page. Execution immediately thereafter will continue with the next instruction in the new page.

An Interrupt Acknowledge cycle is a special case of an Instruction Fetch cycle. When an Interrupt Acknowledge cycle occurs, the contents of the **CPR** and **PC** are saved on the Return Stack and then the **CPR** is cleared to point to page 0. The Interrupt Controller generates a 16-bit address, or "vector", which points to the code to be executed to process the interrupt. To determine how the Interrupt Vector is formed, refer to Figure 4 for the register bit assignments, and also to the Interrupt Controller section.

The page for data access is provided by either **CPR** or **DPR**, as shown in Figures 10 and 12. Data Memory Access instructions can be used to access data in a memory page other than that containing the program code. This is done by writing the desired page number into the Data Page Register (**DPR**) and setting bit 5 (DPRSEL) of the **IBC** Register to 1. If **DPR** is set to equal **CPR**, or if DPRSEL = 0, data will be accessed in the Code page. The status of the DPRSEL bit is saved and restored as a result of a Subroutine Call or Return. When the HS-RTX2010RH is reset, **DPR** points to page 0 and DPRSEL resets to 0, selecting the **CPR**.

**USER MEMORY** consists of blocks of 32 words that can be located anywhere in memory. The word being accessed in a block is pointed to by the five least significant bits of the User Memory instruction (see Table 23), eliminating the need to explicitly load an address into **TOP** before reading or writing to the location. Upon HS-RTX2010RH reset, **UBR** is cleared and points to the block starting at word 0, while **UPR** is cleared so that it points to page 0. The word in the block is pointed to by the five least significant bits of the User Memory instruction and bits 05-01 of the **UBR**. These bits from these two registers are logically OR'ed to produce the address of the word in memory. See Figure 13.

**Word And Byte Main Memory Access**

Using Main Memory Access instructions, the HS-RTX2010RH can perform either word or single byte Main Memory accesses, as well as byte swapping within 16-bit words.

Bit 12 of the Memory Access Opcode (see Table 22), is used to determine whether byte or word operations are to be performed (where bit 12 = 0 signifies a word operation, and bit 12 = 1 signifies a byte operation). In addition, the determination of whether a byte swap is to occur depends on whether Addressing Mode 0 or Mode 1 is in effect (as determined by bit 2 of the **CR**), and on whether an even or odd address is being accessed (see Figures 18 and 19).

Whenever a word of data is read by a Data Memory operation into the processor, it is first placed in the **NEXT** Register. By the time the instruction that reads that word of data is completed, however, the data may have been moved, optionally inverted, or operated on by the ALU, and placed in the **TOP** Register. Whenever a Data Memory operation writes to memory, the data comes from the **NEXT** Register.

The Byte Order Bit is bit 2 of the Configuration Register, **CR** (see Figure 3 in the "RTX Internal Registers Section"). This bit is used to determine whether the default (Mode 0) or byte swap (Mode 1) method will be used in the Data Memory accesses.

Word Access is designated when the **IR** bit 12 = 0 in the Memory Access Opcode, and can take one of two forms, depending upon the status of **CR**, bit 2.

When **CR** bit 2 = 0, the Mode 0 method of word access is designated. Word access to an even address (A0 = 0) results in an unaltered transfer of data, as shown in Figure 18. Word access to/from an odd address (A0 = 1) while in this mode will effectively cause the Byte Order Bit to be complemented and will result in the bytes being swapped.

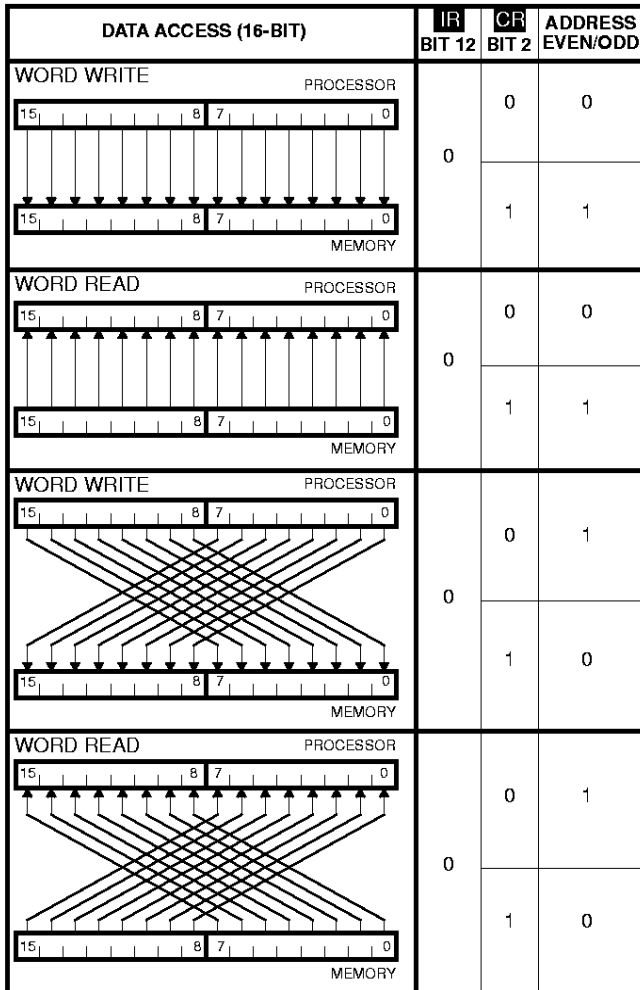

FIGURE 18. MEMORY ACCESS (WORD)

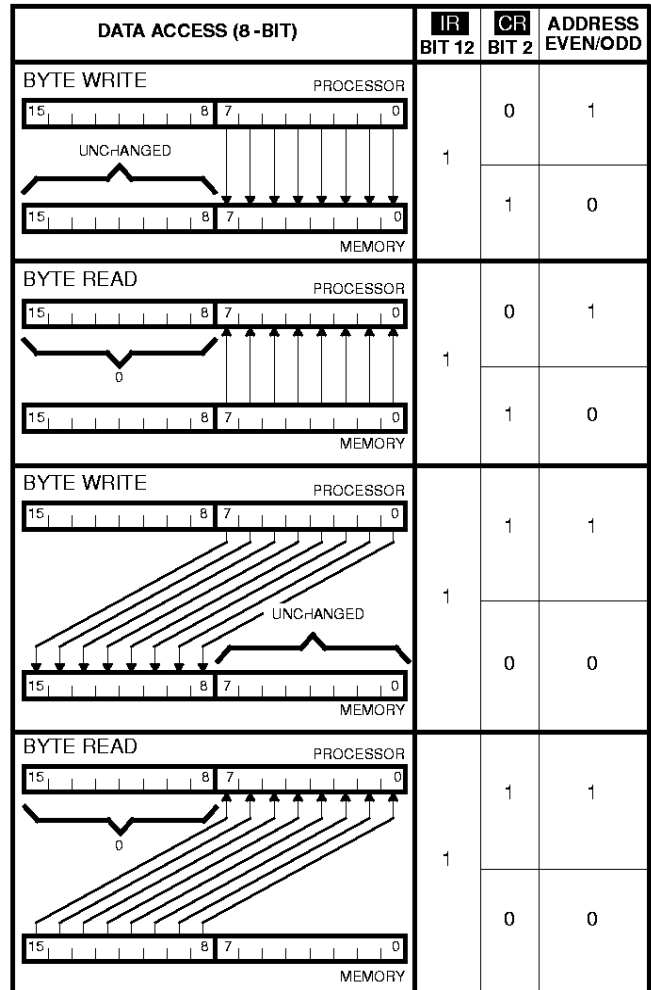

FIGURE 19. MEMORY ACCESS (BYTE)



When the **CR** Bit 2 = 1, the Mode 1 method of word access is designated. Access to an even address (A0 = 0) results in a data transfer in which the bytes are swapped. Word access to an odd address (A0 = 1) while in this mode will effectively cause the Byte Order Bit to be complemented with the net result that no byte swap takes place when the data word is transferred. See Figure 18.

Byte Access is designated when the **IR** bit 12 = 1 in the Memory Access Opcode, and can also take one of two forms, depending on the value of **CR** Bit 2.

When the **CR** Bit 2 = 0, a Byte Read from an even address in Mode 0 causes the upper byte (MD15-MD08) of memory data to be read into the lower byte position (MD07-MD00) of **NEXT**, while the upper byte (MD15-MD08) is set to 0. A Byte Write operation accessing an even address will cause the byte to be written from the lower byte position (MD07-MD00) of **NEXT** into the upper byte position (MD15-MD08) of memory. The data in the lower byte position (MD07-MD00) in memory will be left unaltered. Accessing an odd address for either of these operations will cause the Byte Order Bit to be complemented, with the net result that no swap will occur. See Figure 19.

When **CR** Bit 2 = 1, the Mode 1 method of memory access is used. Accessing an even address in this mode means that a Byte Read operation will cause the lower byte of data to be transferred without a swap operation. A Byte Write in this mode will also result in an unaltered byte transfer. Conversely, accessing an odd address for a byte operation while in Mode 1 will cause the Byte Order Bit to be complemented. In a Byte Read operation, this will result in the upper byte (MD15-MD08) of data being swapped into the lower byte position (MD07-MD00), while the upper byte is set to 0 (MD15-MD08 set to 0). See Figure 19. A Byte Write operation accessing an odd address will cause the byte to be swapped from the lower byte position (MD07-MD00) of the processor register into the upper byte position (MD15-MD08) of the Memory location. The data in the lower byte position (MD07-MD00) in that Memory location will be left unaffected.

NOTE: These features are for Main Memory data access only, and have no effect on instruction fetches, long literals, or User Data Memory.

### Subroutine Calls And Returns

The RTX can perform both "short" subroutine calls and "long" subroutine calls. A short subroutine call is one for which the subroutine code is located within the same Code page as the Call instruction, and no processor cycle time is expended in reloading the **CPR**.

Performing a long subroutine call involves transferring execution to a different Code page. This requires that the **CPR** be loaded with the new Code page as described in the Memory Access Section, followed immediately by the Subroutine Call instruction. This adds two additional cycles to the execution time for the Subroutine Call.

For all instructions except Subroutine Calls or Branch instructions, bit 5 of the instruction code represents the Subroutine Return Bit. If this bit is set to 1, a Return is performed whereby the return address is popped from the Return Stack, as indicated in Figure 11. The page for the return address comes from the **IPR**. The contents of the **I** Register are written to the **PC**, and the contents of the **IPR** are written to the **CPR** so that execution resumes at the point following the Subroutine Call. The Return Stack is also popped at this time.

### HS-RTX2010RH Software

The HS-RTX2010RH is designed around the same architecture as the RTX 2000, and is a hardware implementation of the Virtual Forth Engine. As such, it does not require the additional assembly or machine language software development typical of most real-time microcontrollers.

The instruction set for the HS-RTX2010RH TForth compiler combines multiple high level instructions into single machine instructions without having to rely on either pipelines or caches. This optimization yields an effective throughput which is faster than the processor's clock speed, while avoiding the unpredictable execution behavior exhibited by most RISC processors caused by pipeline flushes and cache misses.

### 2010 Compilers

Harris offers a complete ANSI C cross development environment for the HS-RTX2010RH. The environment provides a powerful, user-friendly set of software tools designed to help the developers of embedded real-time control systems get their designs to market quickly. The environment includes the optimized ANSI C language compiler, symbolic menu driven C language debugger, RTX assembler, linker, profiler, and PROM programmer interface.

The HS-RTX2010RH TForth compiler from Harris translates Forth-83 source code to HS-RTX2010RH machine instructions. This compiler also provides support for all of the HS-RTX2010RH instructions specific to the processor's registers, peripherals, and ASIC Bus. See the tables in the following sections for instruction set information.

TABLE 12. INSTRUCTION SET SUMMARY

NOTATIONS	DEFINITION
m-read	Read data (byte or word) from memory location addressed by contents of <b>TOP</b> Register into <b>TOP</b> Register.
m-write	Write contents (byte or word) of <b>NEXT</b> Register into memory location addressed by contents of <b>TOP</b> Register.
g-read	Read data from the ASIC address (address field ggggg of instruction) into <b>TOP</b> Register. A read of one of the on-chip peripheral registers can be done with a g-read command.
g-write	Write contents of <b>TOP</b> Register to ASIC address (address field ggggg of instruction). A write to one of the on-chip peripheral registers can be done with a g-write command.
u-read	Read contents (word only) of User Space location (address field uuuuu of instruction) into <b>TOP</b> Register.
u-write	Write contents (word only) of <b>TOP</b> Register into User Space location (address field uuuuu of instruction).
SWAP	Exchange contents of <b>TOP</b> and <b>NEXT</b> registers.
DUP	Copy contents of <b>TOP</b> Register to <b>NEXT</b> Register, pushing previous contents of <b>NEXT</b> onto Stack Memory.
OVER	Copy contents of <b>NEXT</b> Register to <b>TOP</b> Register, pushing original contents of <b>TOP</b> to <b>NEXT</b> Register and original contents of <b>NEXT</b> Register to Stack Memory.
DROP	Pop Parameter Stack, discarding original contents of <b>TOP</b> Register, leaving the original contents of <b>NEXT</b> in <b>TOP</b> and the original contents of the top Stack Memory location in <b>NEXT</b> .
inv	Perform 1's complement on contents of <b>TOP</b> Register, if i bit in instruction is 1.
alu-op	Perform appropriate cccc or aaa ALU operation from Table 26 on contents of <b>TOP</b> and <b>NEXT</b> registers.
shift	Perform appropriate shift operation (sssss field of instruction) from Table 27 on contents of <b>TOP</b> and/or <b>NEXT</b> registers.
d	Push short literal d from ddddd field of instruction onto Parameter Stack (where ddddd contains the actual value of the short literal). The original contents of <b>TOP</b> are pushed into <b>NEXT</b> , and the original contents of <b>NEXT</b> are pushed onto Stack Memory.
D	Push long literal D from next sequential location in program memory onto Parameter Stack. The original contents of <b>TOP</b> are pushed into <b>NEXT</b> , and the original contents of <b>NEXT</b> are pushed onto Stack Memory.
R	Perform a Return From Subroutine if bit = 1.

NOTE: All unused opcodes are reserved for future architectural enhancements.

TABLE 13. INSTRUCTION REGISTER BIT FIELDS (BY FUNCTION)

FUNCTION CODE	DEFINITION
ggggg	Address field for ASIC Bus locations
uuuuu	Address field for User Space memory locations
cccc aaa	ALU functions (see Table 26)
dddd	Short literals (containing a value from 0 to 31)
ssss	Shift Functions (see Table 27)

# HS-RTX2010RH

TABLE 14. HS-RTX2010RH **I** AND **PC** ACCESS OPERATIONS (Note)

OPERATION (g-read, g-write)	RETURN BIT VALUE	ASIC ADDRESS ggggg	REGISTER	FUNCTION
Read mode	0	00000	<b>I</b>	Pushes the contents of <b>I</b> into <b>TOP</b> (with no pop of the Return Stack)
Read mode	1	00000	<b>I</b>	Pushes the contents of <b>I</b> into <b>TOP</b> , then performs a Subroutine Return
Write mode	0	00000	<b>I</b>	Pops the contents of <b>TOP</b> into <b>I</b> (with no push of the Return Stack)
Write mode	1	00000	<b>I</b>	Performs a Subroutine Return, then pushes the contents of <b>TOP</b> into <b>I</b>
Read mode	0	00001	<b>I</b>	Pushes the contents of <b>I</b> into <b>TOP</b> , popping the Return Stack
Read mode	1	00001	<b>I</b>	Pushes the contents of <b>I</b> into <b>TOP</b> without popping the Return Stack, then executes the Subroutine Return
Write mode	0	00001	<b>I</b>	Pushes the contents of <b>TOP</b> into <b>I</b> popping the Parameter Stack
Write mode	1	00001	<b>I</b>	Performs a Subroutine Return, then pushes the contents of <b>TOP</b> into <b>I</b>
Read mode	0	00010	<b>I</b>	Pushes the contents of <b>I</b> shifted left by one bit, into <b>TOP</b> (the Return Stack is not popped)
Read mode	1	00010	<b>I</b>	Pushes the contents of <b>I</b> shifted left by one bit, into <b>TOP</b> (the Return Stack is not popped), then performs a Subroutine Return
Write mode	0	00010	<b>I</b>	Pushes the contents of <b>TOP</b> into <b>I</b> as a "stream" count, indicating that the next instruction is to be performed a specified number of times; the Parameter Stack is popped
Write mode	1	00010	<b>I</b>	Performs a Subroutine Return, then pushes the stream count into <b>I</b>
Read mode	0	00111	<b>PC</b>	Pushes the contents of <b>PC</b> into <b>TOP</b>
Read mode	1	00111	<b>PC</b>	Pushes the contents of <b>PC</b> into <b>TOP</b> , then performs a Subroutine Return
Write mode	0	00111	<b>PC</b>	Performs a Subroutine Call to the address contained in <b>TOP</b> , popping the Parameter Stack
Write mode	1	00111	<b>PC</b>	Pushes the contents of <b>TOP</b> onto the Return Stack before executing the Subroutine Return

NOTE: See the RTX Programmer's Reference Manual for a complete listing of typical software functions.

TABLE 15. HS-RTX2010RH RESERVED I/O OPCODES

INSTRUCTION CODE				OPERATION
15 14 13 12	11 10 9 8	7 6 5 4	3 2 1 0	
1 0 1 1	0 0 0 0	1 0 R 0	1 1 0 1	Select <b>DPR</b>
1 0 1 1	0 0 0 0	0 0 R 0	1 1 0 1	Select <b>CPR</b>
1 0 1 1	0 0 0 0	1 0 R 1	0 0 0 0	SeSOFTINT
1 0 1 1	0 0 0 0	0 0 R 1	0 0 0 0	Clear SOFTINT

TABLE 16. SUBROUTINE CALL INSTRUCTIONS

INSTRUCTION CODE				OPERATION
15 14 13 12	11 10 9 8	7 6 5 4	3 2 1 0	
0 a a a	a a a a	a a a a	a a a a	Call word address aaaa aaaa aaaa aaa0, in the page indicated by <b>CPR</b> . This address is produced when the processor performs a left shift on the address in the instruction code.

Subroutine Call Bit  
(Bit 15 = 0: Call,  
Bit 15 = 1: No Call)

TABLE 17. SUBROUTINE RETURN

INSTRUCTION CODE				OPERATION
15 14 13 12	11 10 9 8	7 6 5 4	3 2 1 0	
- - - -	- - - -	- - R -	- - - -	Return from subroutine

Subroutine Return Bit (Note)   
 (Bit 5, R = 0: No return R = 1: Return)

NOTE: Does not apply to Subroutine Call or Branch Instructions. A Subroutine Return can be combined with any other instruction (as implied here by hyphens).

TABLE 18. BRANCH INSTRUCTIONS

INSTRUCTION CODE				OPERATION
15 14 13 12	11 10 9 8	7 6 5 4	3 2 1 0	
1 0 0 0	0 b b a	a a a a	a a a a	DROP and branch if <b>TOP</b> = 0
1 0 0 0	1 b b a	a a a a	a a a a	Branch if <b>TOP</b> = 0
1 0 0 1	0 b b a	a a a a	a a a a	Unconditional branch
1 0 0 1	1 b b a	a a a a	a a a a	Branch and decrement <b>I</b> if <b>I</b> ≠ 0; Pop <b>I</b> if <b>I</b> = 0

Branch Address   
 (Note)

NOTE: See the Programmer's Reference Manual for further information regarding the branch address field.

TABLE 19. REGISTER AND I/O ACCESS INSTRUCTIONS

INSTRUCTION CODE				OPERATION
15 14 13 12	11 10 9 8	7 6 5 4	3 2 1 0	
1 0 1 1	0 0 0 i	0 0 R g	g g g g	g-read DROP      inv
1 0 1 1	1 1 1 i	0 0 R g	g g g g	g-read            inv
1 0 1 1	c c c c	0 0 R g	g g g g	g-read OVER      alu-op
1 0 1 1	0 0 0 i	1 0 R g	g g g g	DUP g-write      inv
1 0 1 1	1 1 1 i	1 0 R g	g g g g	g-write            inv
1 0 1 1	c c c c	1 0 R g	g g g g	g-read SWAP      alu-op

TABLE 20. SHORT LITERAL INSTRUCTIONS

INSTRUCTION CODE				OPERATION
15 14 13 12	11 10 9 8	7 6 5 4	3 2 1 0	
1 0 1 1	0 0 0 i	0 1 R d	d d d d	d DROP            inv
1 0 1 1	1 1 1 i	0 1 R d	d d d d	d                    inv
1 0 1 1	c c c c	0 1 R d	d d d d	d OVER            alu-op
1 0 1 1	1 1 1 i	1 1 R d	d d d d	d SWAP DROP      inv
1 0 1 1	c c c c	1 1 R d	d d d d	d SWAP            alu-op

TABLE 21. LONG LITERAL INSTRUCTIONS

INSTRUCTION CODE				OPERATION													
15	14	13	12	11	10	9	8	7	6	5	4	3	2	1	0	(1ST CYCLE)	(2ND CYCLE)
1	1	0	1	0	0	0	i	0	0	R	0	0	0	0	0	D SWAP	inv
1	1	0	1	1	1	1	i	0	0	R	0	0	0	0	0	D SWAP	SWAP inv
1	1	0	1	c	c	c	c	0	0	R	0	0	0	0	0	D SWAP	SWAP OVER alu-op
1	1	0	1	1	1	1	i	1	0	R	0	0	0	0	0	D SWAP	DROP inv
1	1	0	1	c	c	c	c	1	0	R	0	0	0	0	0	D SWAP	alu-op

TABLE 22. MEMORY ACCESS INSTRUCTIONS

INSTRUCTION CODE				OPERATION													
15	14	13	12	11	10	9	8	7	6	5	4	3	2	1	0	(1ST CYCLE)	(2ND CYCLE)
1	1	1	s	0	0	0	i	0	0	R	0	0	0	0	0	m-read SWAP	inv
1	1	1	s	1	1	1	i	0	0	R	0	0	0	0	0	m-read SWAP	SWAP inv
1	1	1	s	c	c	c	c	0	0	R	0	0	0	0	0	m-read SWAP	SWAP OVER alu-op
1	1	1	s	0	0	0	p	0	1	R	0	0	0	0	0	(SWAP DROP) DUP m-read SWAP	NOP
1	1	1	s	1	1	1	p	0	1	R	d	d	d	d	d	(SWAP DROP) m-read d	NOP
1	1	1	s	a	a	a	p	0	1	R	d	d	d	d	d	(SWAP DROP) DUP m-read SWAP d SWAP alu-op	NOP
1	1	1	s	0	0	0	i	1	0	R	0	0	0	0	0	OVER SWAP m-write	inv
1	1	1	s	1	1	1	i	1	0	R	0	0	0	0	0	OVER SWAP m-write	DROP inv
1	1	1	s	c	c	c	c	1	0	R	0	0	0	0	0	m-read SWAP	alu-op
1	1	1	s	0	0	0	p	1	1	R	0	0	0	0	0	(OVER SWAP) SWAP OVER m-write	NOP
1	1	1	s	1	1	1	p	1	1	R	d	d	d	d	d	(OVER SWAP) m-write d	NOP
1	1	1	s	a	a	a	p	1	1	R	d	d	d	d	d	(OVER SWAP) SWAP OVER m-write d SWAP alu-op	NOP

If (p = 0), perform either (SWAP DROP) or (OVER SWAP)

If s = 0, Memory is accessed by word  
If s = 1, Memory is accessed by byte

NOTE: SWAP d SWAP ≡ d ROT

TABLE 23. USER SPACE INSTRUCTIONS

INSTRUCTION CODE				OPERATION	
15 14 13 12	11 10 9 8	7 6 5 4	3 2 1 0	(1ST CYCLE)	(2ND CYCLE)
1 1 0 0	0 0 0 i	0 0 R u	u u u u	u-read SWAP	inv
1 1 0 0	1 1 1 i	0 0 R u	u u u u	u-read SWAP	SWAP inv
1 1 0 0	c c c c	0 0 R u	u u u u	u-read SWAP	SWAP OVER alu-op
1 1 0 0	0 0 0 i	1 0 R u	u u u u	DUP u-write	inv
1 1 0 0	1 1 1 i	1 0 R u	u u u u	DUP u-write	DROP inv
1 1 0 0	c c c c	1 0 R u	u u u u	u-read SWAP	alu-op

TABLE 24. ALU FUNCTION INSTRUCTIONS

INSTRUCTION CODE				OPERATION	
15 14 13 12	11 10 9 8	7 6 5 4	3 2 1 0		
1 0 1 0	0 0 0 i	0 0 R 0	s s s s	inv shift	
1 0 1 0	1 1 1 i	0 0 R 0	s s s s	DROP DUP	inv shift
1 0 1 0	c c c c	0 0 R 0	s s s s	OVER SWAP	alu-op shift
1 0 1 0	0 0 0 i	0 1 R 0	s s s s	SWAP DROP	inv shift
1 0 1 0	1 1 1 i	0 1 R 0	s s s s	DROP	inv shift
1 0 1 0	c c c c	0 1 R 0	s s s s		alu-op shift
1 0 1 0	0 0 0 i	1 0 R 0	s s s s	SWAP DROP DUP	inv shift
1 0 1 0	1 1 1 i	1 0 R 0	s s s s	SWAP	inv shift
1 0 1 0	c c c c	1 0 R 0	s s s s	SWAP OVER	alu-op shift
1 0 1 0	0 0 0 i	1 1 R 0	s s s s	DUP	inv shift
1 0 1 0	1 1 1 i	1 1 R 0	s s s s	OVER	inv shift
1 0 1 0	c c c c	1 1 R 0	s s s s	OVER OVER	alu-op shift

TABLE 25. STEP MATH FUNCTIONS (NOTE 1)

INSTRUCTION CODE				OPERATION	
15 14 13 12	11 10 9 8	7 6 5 4	3 2 1 0		
1 0 1 0	- - - -	- - - 1	- - - -	(See the Programmer's Reference Manual)	

NOTE:

- These instructions perform multi-step math functions such as multiplication, division and square root functions. Use of either the Streamed instruction mode or masking of interrupts is recommended to avoid erroneous results when performing Step Math operations.
  - Unsigned Division:
    - Load dividend into **TOP** and **NEXT**
    - Load divisor into **MD**
    - Execute single step form of D2 (Note 1) instruction 1 time
    - Execute opcode A41A 1 time
    - Execute opcode A45A 14 times
    - Execute opcode A458 1 time
    - The quotient is in **NEXT**, the remainder in **TOP**
  - Square Root Operations:
    - Load value into **TOP** and **NEXT**
    - Load 8000H into **SR**
    - Load 0 into **MD**
    - Execute single step form of D2 (Note 1) instruction 1 time
    - Execute opcode A51A 1 time
    - Execute opcode A55A 14 times
    - Execute opcode A558 1 time
    - The root is in **NEXT**, the remainder in **TOP**

## HS-RTX2010RH

**TABLE 26. ALU LOGIC FUNCTIONS/OPCODES**

cccc	aaa	FUNCTION
0010	001	AND
0011		NOR
0100	010	SWAP-
0101		SWAP-c With Borrow
0110	011	OR
0111		NAND
1000	100	+
1001		+c With Carry
1010	101	XOR
1011		XNOR
1100	110	-
1101		-c With Borrow

**TABLE 27. SHIFT FUNCTIONS**

SHIFT ssss	NAME	FUNCTION	STATUS OF C	TOP REGISTER			NEXT REGISTER		
				T15	Tn	T0	N15	Nn	N0
0000		No Shift	CY	Z15	Zn	Z0	TN15	TNn	TN0
0001	0<	Sign Extend	CY	Z15	Z15	Z15	TN15	TNn	TN0
0010	2*	Arithmetic Left Shift	Z15	Z14	Zn-1	0	TN15	TNn	TN0
0011	2*c	Rotate Left	Z15	Z14	Zn-1	CY	TN15	TNn	TN0
0100	cU2/	Right Shift Out of Carry	0	CY	Zn+1	Z1	TN15	TNn	TN0
0101	c2/	Rotate Right Through Carry	Z0	CY	Zn+1	Z1	TN15	TNn	TN0
0110	U2/	Logical Right Shift	0	0	Zn+1	Z1	TN15	TNn	TN0
0111	2/	Arithmetic Right Shift	Z15	Z15	Zn+1	Z1	TN15	TNn	TN0
1000	N2*	Left Shift of <b>NEXT</b>	CY	Z15	Zn	Z0	TN14	TNn-1	0
1001	N2*c	Rotate <b>NEXT</b> Left	CY	Z15	Zn	Z0	TN14	TNn-1	CY
1010	D2*	32-Bit Left Shift	Z15	Z14	Zn-1	TN15	TN14	TNn-1	0
1011	D2*c	32-Bit Rotate Left	Z15	Z14	Zn-1	TN15	TN14	TNn-1	CY
1100	cUD2/	32-Bit Right Shift Out of Carry	0	CY	Zn+1	Z1	Z0	TNn+1	TN1
1101 (Note)	cD2/	32-Bit Rotate Right Through Carry	TN0	CY	Zn+1	Z1	Z0	TNn+1	TN1
1110	UD2/	32-Bit Logical Right Shift	0	0	Zn+1	Z1	Z0	TNn+1	TN1
1111	D2/	32-Bit Right Shift	Z15	Z15	Zn+1	Z1	Z0	TNn+1	TN1

NOTE: See the Programmer's Reference Manual

Where: T15-Most significant bit of **TOP**

Tn-Typical bit of **TOP**

T0-Least significant bit of **TOP**

N15-Most significant bit of **NEXT**

Nn-Typical bit of **NEXT**

N0-Least significant bit of **NEXT**

C-Carry bit

CY-Carry bit before operation

Zn-ALU output

Z15-Most significant bit 15 of ALU output

TNn-Original value of typical bit of **NEXT**

TABLE 28. MAC/BARREL SHIFTER/LZD INSTRUCTIONS

INSTRUCTION CODE				OPERATION												
15	14	13	12	11	10	9	8	7	6	5	4	3	2	1	0	
1	0	1	1	0	0	0	0	0	R	0	1	0	0	0		Forth 0 =
1	0	1	1	0	0	0	0	0	R	0	1	0	0	1		Double Shift Right Arithmetic
1	0	1	1	0	0	0	0	0	R	0	1	0	1	0		Double Shift Right Logical
1	0	1	1	0	0	0	0	0	R	0	1	1	0	0		Clear MAC Accumulator
1	0	1	1	0	0	0	0	0	R	0	1	1	1	0		Double Shift Left Logical
1	0	1	1	0	0	0	0	0	R	0	1	1	1	1		Floating Point Normalize
1	0	1	1	0	0	0	0	0	R	1	0	0	0	1		Shift MAC Output Regs Right
1	0	1	1	0	0	0	0	0	R	1	0	0	1	0		Streamed MAC Between Stack and Memory
1	0	1	1	0	0	0	0	1	R	1	0	0	1	0		Streamed MAC Between ASIC Bus and Memory
1	0	1	1	0	0	0	0	0	R	1	0	0	1	1		Mixed Mode Multiply
1	0	1	1	0	0	0	0	1	R	1	0	1	1	0		Unsigned Multiply
1	0	1	1	0	0	0	0	1	R	1	0	1	1	1		Signed Multiply
1	0	1	1	0	0	0	0	0	R	1	0	1	0	0		Signed Multiply and Subtract from Accumulator
1	0	1	1	0	0	0	0	0	R	1	0	1	0	1		Mixed Mode Multiply Accumulate
1	0	1	1	0	0	0	0	0	R	1	0	1	1	0		Unsigned Multiply Accumulate
1	0	1	1	0	0	0	0	0	R	1	0	1	1	1		Signed Multiply Accumulate
1	0	1	1	1	1	1	0	0	R	1	0	0	1	0		Load MXR Register
1	0	1	1	1	1	1	0	0	R	1	0	1	1	0		Load MLR Register
1	0	1	1	1	1	1	0	0	R	1	0	1	1	1		Load MHR Register
1	0	1	1	1	1	1	0	1	R	1	0	0	1	0		Store MXR Register
1	0	1	1	1	1	1	0	1	R	1	0	1	1	0		Store MLR Register
1	0	1	1	1	1	1	0	1	R	1	0	1	1	1		Store MHR Register



# HS-RTX2010RH

## Metallization Topology

### DIE DIMENSIONS:

364 x 371 x 21 1mils

### METALLIZATION:

Type: Al/Si/Cu

Thickness:  $7.5k\text{\AA} \pm 2k\text{\AA}$

### GLASSIVATION:

Type:  $\text{SiO}_2$

Thickness:  $8k\text{\AA} \pm 1k\text{\AA}$

### WORST CASE CURRENT DENSITY:

$1.0 \times 10^5 \text{ A/cm}^2$

## Metallization Mask Layout

HS-RTX2010RH

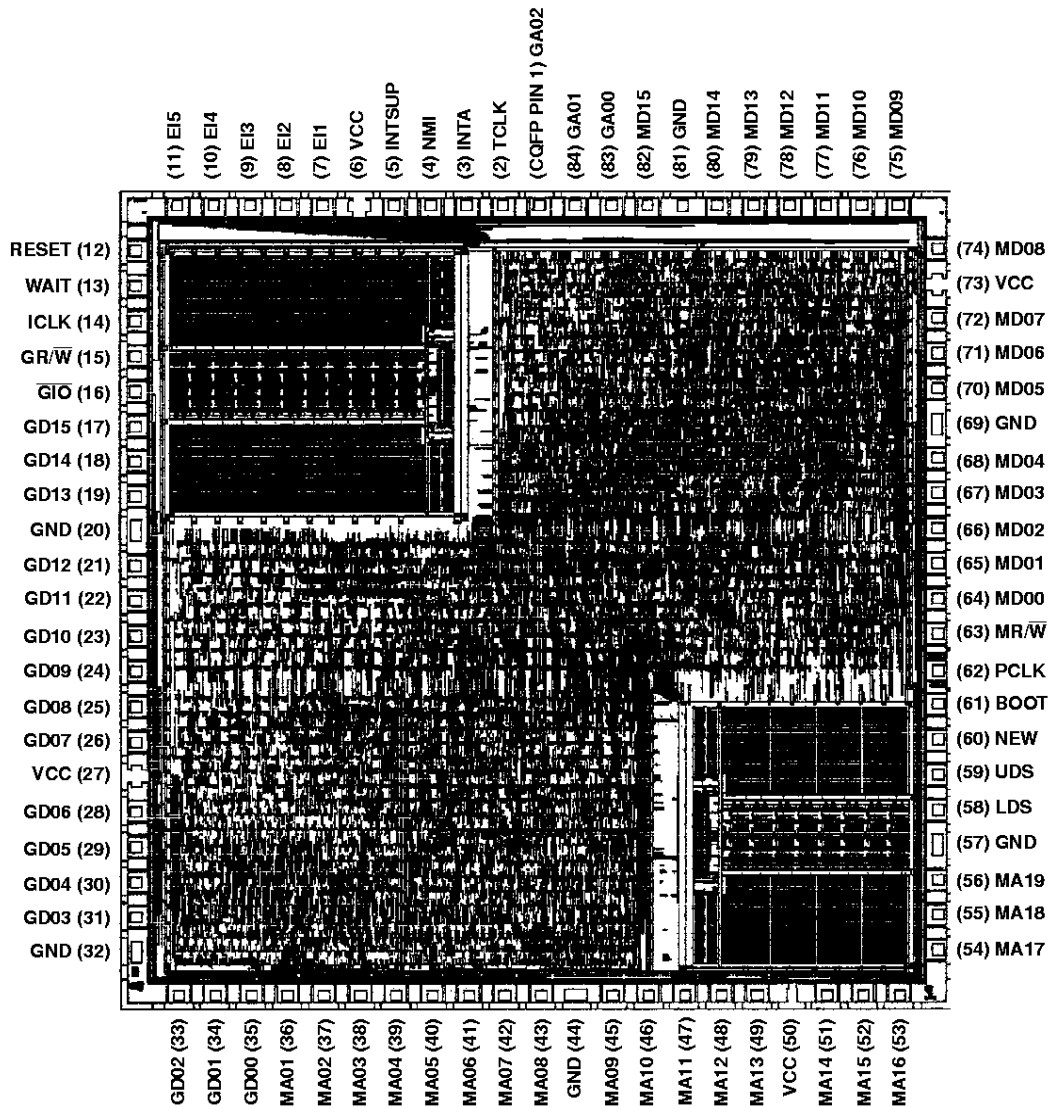

# HS-RTX2010RH

## Test Program Timing

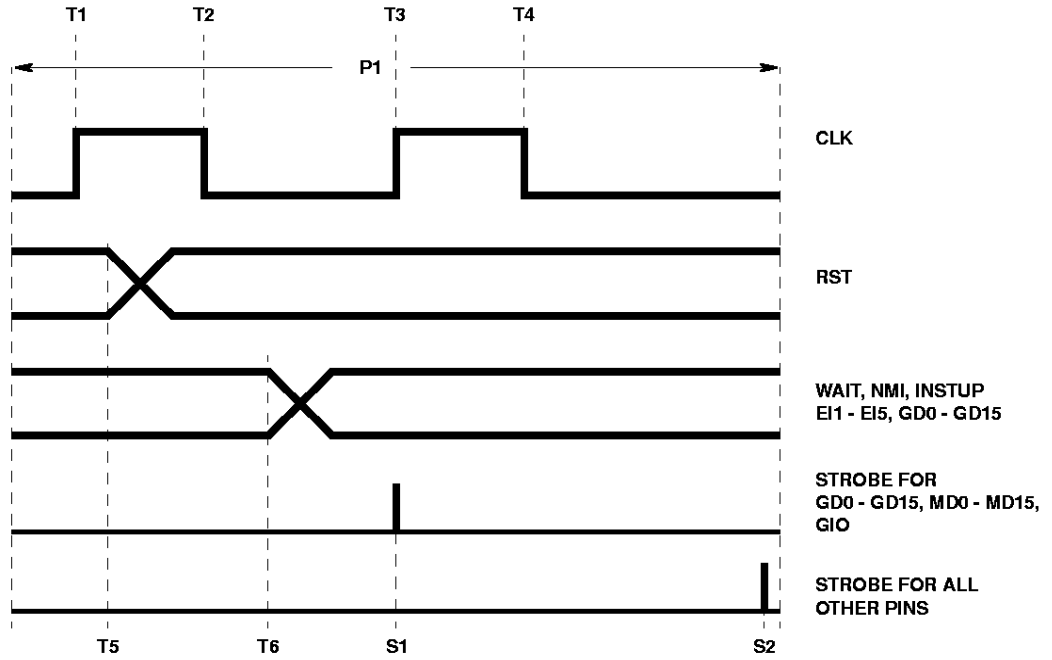

SLOW SPEED	1MHz	8MHz	FMAX1	FMAX2	AC1
P1 = 500ns	P1 = 2000ns	P1 = 250ns	P1 = 125ns	P1 = 125ns	PER1 = 500ns
T1 = 25ns	T1 = 100ns	T1 = 12ns	T1 = 5ns	T1 = 5ns	T1 = 10ns
T2 = 125ns	T2 = 500ns	T2 = 62ns	T2 = 36ns	T2 = 43ns	T2 = 135ns
T3 = 250ns	T3 = 1000ns	T3 = 125ns	T3 = 67ns	T3 = 67ns	T3 = 260ns
T4 = 350ns	T4 = 1400ns	T4 = 175ns	T4 = 98ns	T4 = 91ns	T4 = 385ns
T5 = 75ns	T5 = 300ns	T5 = 37ns	T5 = 25ns	T5 = 25ns	T5 = 65ns
T6 = 175ns	T6 = 700ns	T6 = 88ns	T6 = 35ns	T6 = 35ns	T6 = 185ns
S1 = 245 - 255ns	S1 = N/A	S1 = 10 - 15ns	S1 = 10 - 15ns	S1 = 10 - 15ns	S1 = 475 - 485ns
S2 = 470 - 480ns	S2 = N/A	S2 = 10 - 15ns	S2 = 55 - 60ns	S2 = 60 - 65ns	S2 = 255 - 265ns

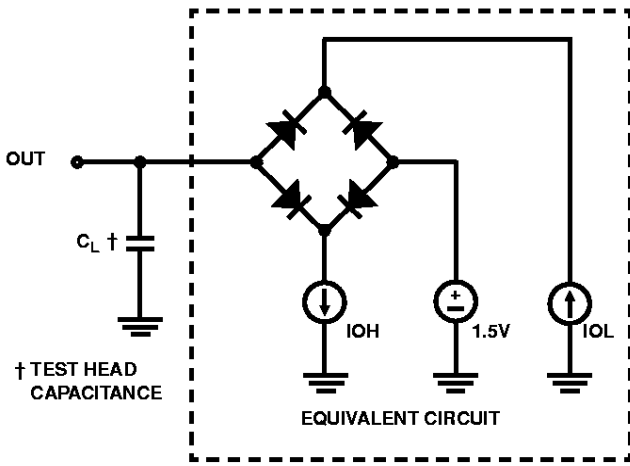

FIGURE 20. TEST CIRCUIT

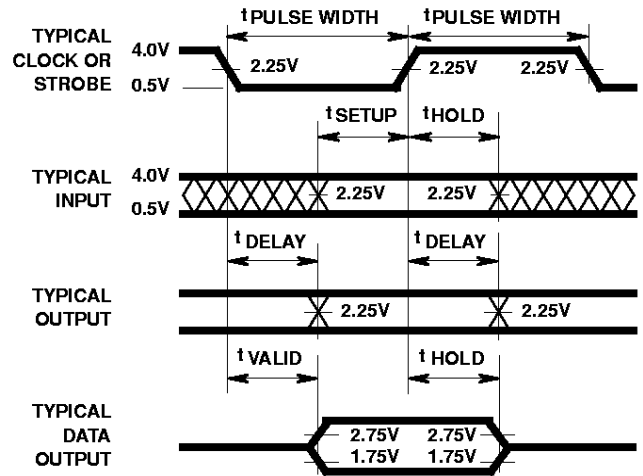
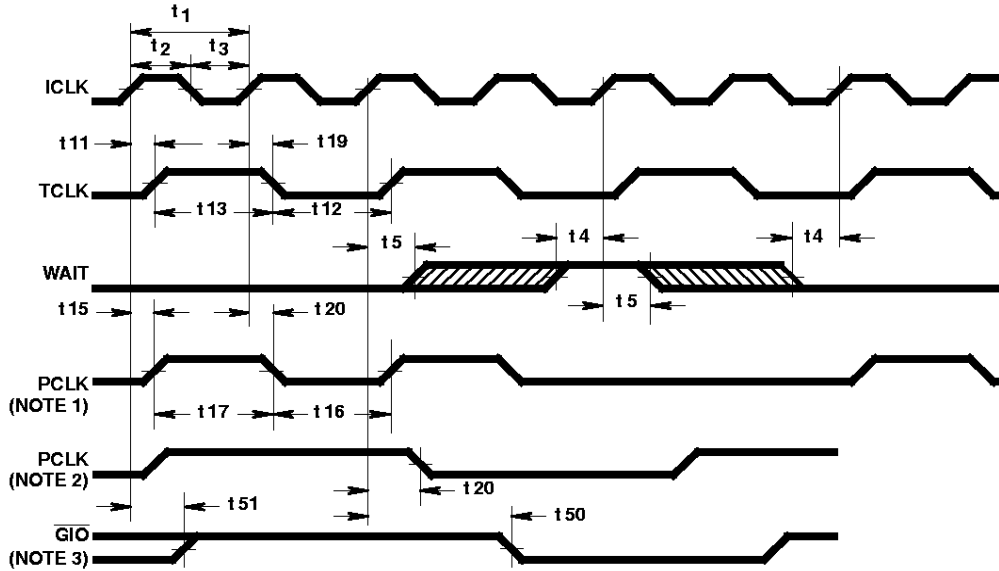

FIGURE 21. AC DRIVE AND MEASURE POINTS - CLK INPUT

NOTE: For AC testing input rise and fall times are driven at 1V/ns

**Timing Diagrams**



NOTES:

1. NORMAL CYCLE: This waveform describes a normal PCLK cycle and a PCLK cycle with a Wait state.
2. EXTENDED CYCLE: This waveform describes a PCLK cycle for a USER memory access or an external ASIC Bus read cycle when the CYCEXT bit or ARCE bit is set.
3. EXTENDED CYCLE: This waveform describes a  $\overline{GIO}$  cycle for an external ASIC Bus read when the ARCE bit is set.
4. An active HIGH signal on the RESET input is guaranteed to reset the processor if its duration is greater than or equal to 4 rising edges of ICLK plus 1/2 ICLK cycle setup and hold times. If the RESET input is active for less than four rising edges of ICLK, the processor will not reset.

FIGURE 22. CLOCK AND WAIT TIMING

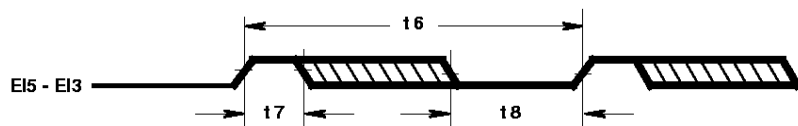
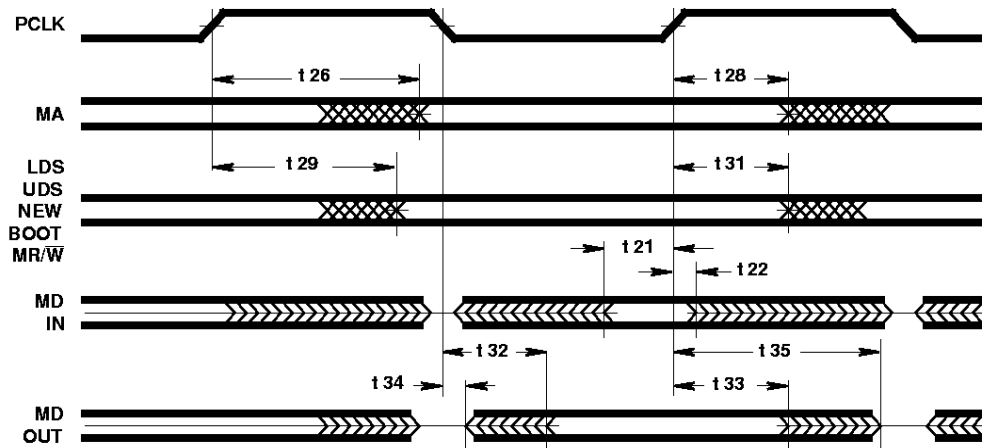

FIGURE 23. TIMER/COUNTER TIMING

Timing Diagrams (Continued)



NOTES:

1. If both LDS and UDS are low, no memory access is taking place in the current cycle. This only occurs during streamed instructions that do not access memory.
2. During a streamed single cycle instruction, the Memory Data Bus is driven by the processor.

FIGURE 24. MEMORY BUS TIMING

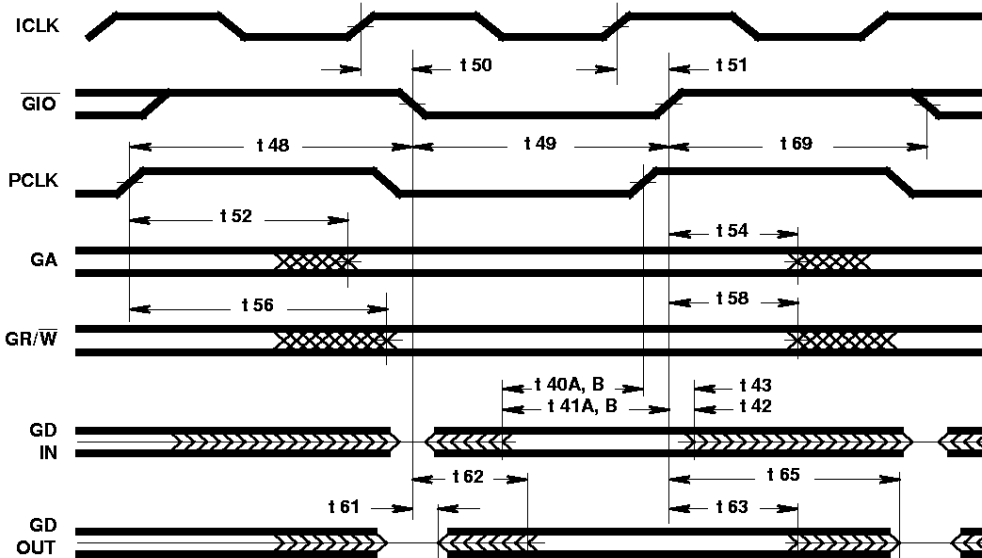

NOTES:

1.  $\overline{GIO}$  remains high for internal ASIC bus cycles.
2.  $\overline{GR/W}$  goes low and GD is driven for all ASIC write cycles, including internal ones.
3. During non-ASIC write cycles, GD is not driven by the HS-RTX2010RH. Therefore, it is recommended that all GD pins be pulled to VCC or GND to minimize power supply current and noise.
4. t40B and t41B specifications are for Streamed Mode of operation only.

FIGURE 25. ASIC BUS TIMING

Timing Diagrams (Continued)

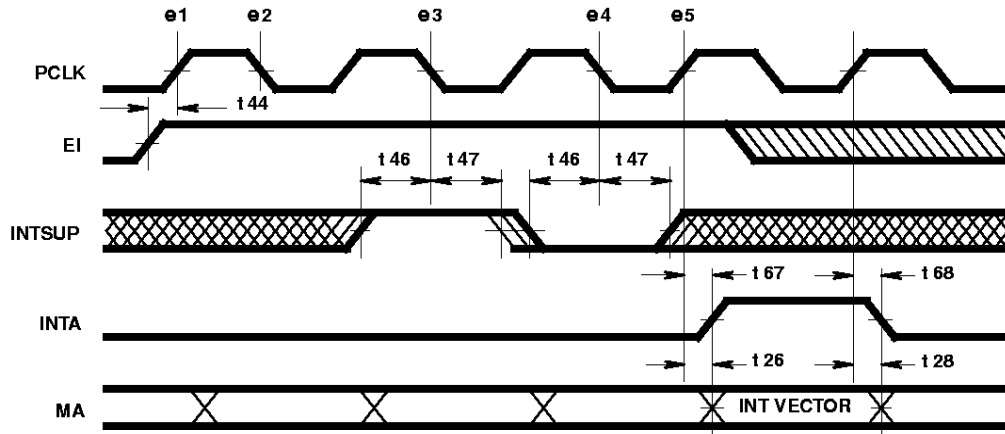

NOTES:

1. Events in an interrupt sequence are as follows:
  - e1. The Interrupt Controller samples the interrupt request inputs on the rising edge of PCLK. If NMI rises between e1 and the rising edge of PCLK prior to e5, the interrupt vector will be for NMI.
  - e2. If any interrupt requests were sampled, the Interrupt Controller issues an interrupt request to the core on the falling edge of PCLK.
  - e3. The core samples the state of the interrupt requests from the Interrupt Controller on the falling edge of PCLK. If INTSUP is high, maskable interrupts will not be detected at this time.
  - e4. When the core samples an interrupt request on the falling edge of PCLK, an Interrupt Acknowledge cycle will begin on the next rising edge of PCLK.
  - e5. Following the detection of an interrupt request by the core, an Interrupt Acknowledge cycle begins. The interrupt vector will be based on the highest priority interrupt request active at this time.
2. t44 is only required to determine when the Interrupt Acknowledge cycle will occur.
3. Interrupt requests should be held active until the Interrupt Acknowledge cycle for that interrupt occurs.

FIGURE 26. INTERRUPT TIMING: WITH INTERRUPT SUPPRESSION

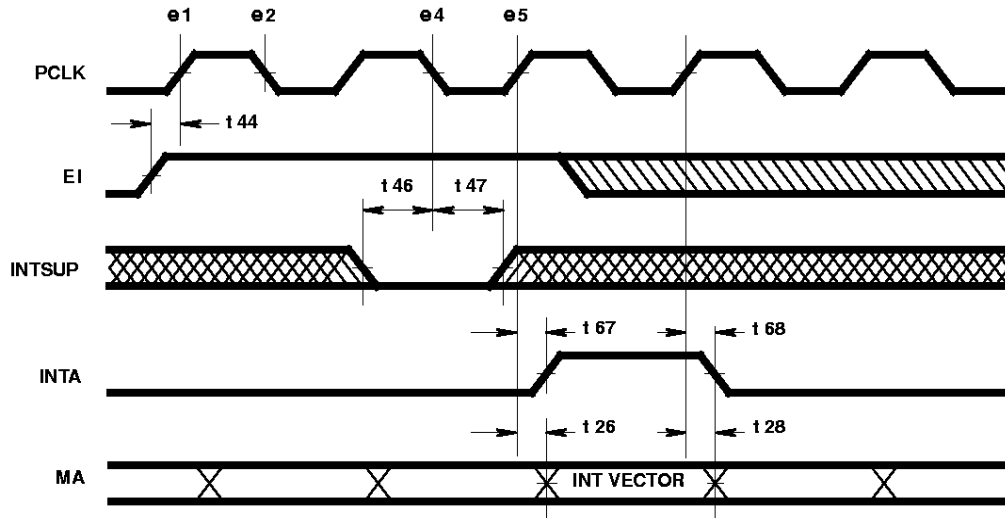
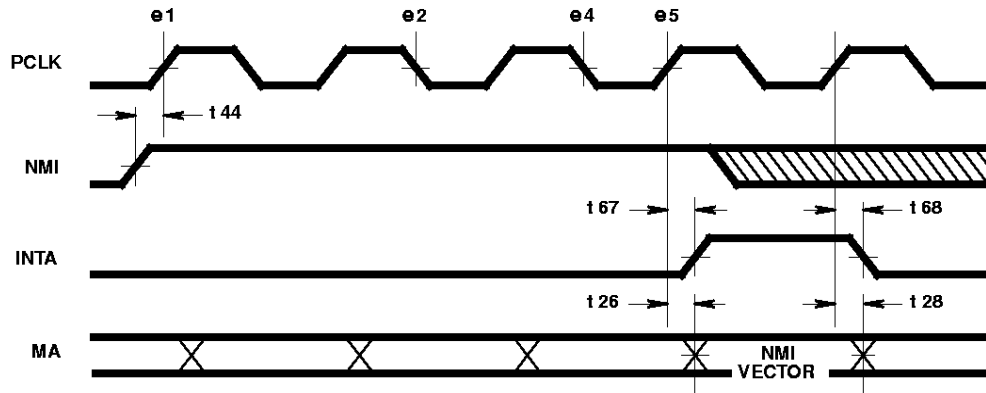

FIGURE 27. INTERRUPT TIMING: WITH NO INTERRUPT SUPPRESSION

**Timing Diagrams** (Continued)



**NOTES:**

1. Events in an interrupt sequence are as follows:
  - e1. The Interrupt Controller samples the interrupt request inputs on the rising edge of PCLK. If NMI rises between e1 and the rising edge of PCLK prior to e5, the interrupt vector will be for NMI.
  - e2. If any interrupt requests were sampled, the Interrupt Controller issues an interrupt request to the core on the falling edge of PCLK.
  - e4. When the core samples an interrupt request on the falling edge of PCLK, an Interrupt Acknowledge cycle will begin on the next rising edge of PCLK.
  - e5. Following the detection of an interrupt request by the core, an Interrupt Acknowledge cycle begins. The interrupt vector will be based on the highest priority interrupt request active at this time.
2. t44 is only required to determine when the Interrupt Acknowledge cycle will occur.
3. Interrupt requests should be held active until the Interrupt Acknowledge cycle for that interrupt occurs.
4. NMI has a glitch filter which requires the signal that initiates NMI last at least two rising and two falling edges of ICLK.

**FIGURE 28. NON-MASKABLE INTERRUPT TIMING**

Ceramic Quad Flatpack (CQFP)

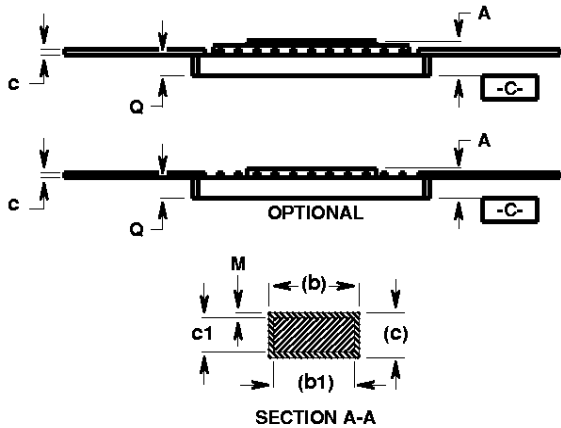
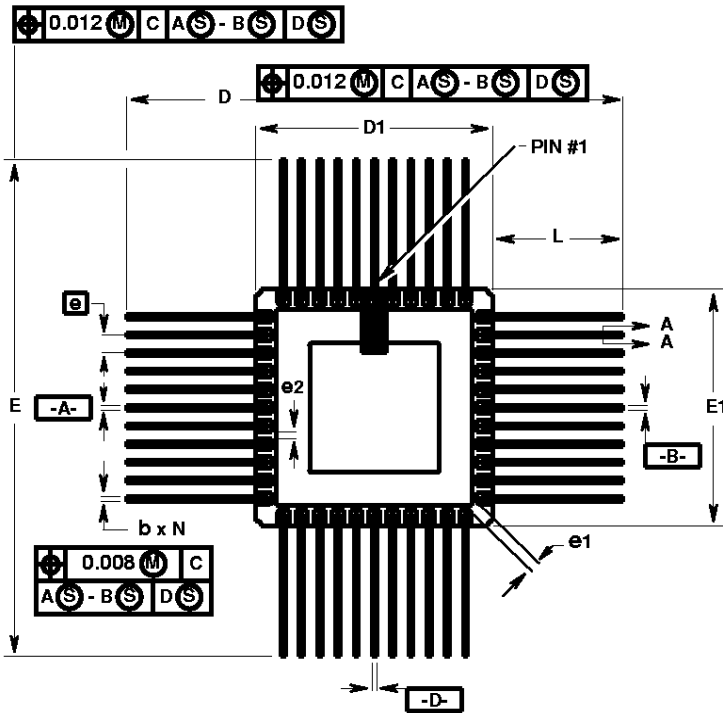

R84.A

84 LEAD CERAMIC QUAD FLATPACK PACKAGE

SYM-BOL	INCHES		MILLIMETERS		NOTES
	MIN	MAX	MIN	MAX	
A	-	0.105	-	2.67	-
b	0.015	0.022	0.38	0.56	2
b1	0.015	0.019	0.38	0.48	2
c	0.008	0.015	0.20	0.38	2
c1	0.008	0.012	0.20	0.30	2
D	1.800	2.000	45.72	50.80	-
E	1.800	2.000	45.72	50.80	-
D1	1.135	1.170	28.83	29.72	-
E1	1.135	1.170	28.83	29.72	-
e	0.050 BSC		1.27 BSC		-
e1	0.012	-	0.30	-	4
e2	0.012	-	0.30	-	-
L	0.320	0.450	8.13	11.43	-
Q	0.070	0.090	1.78	2.29	6
M	-	0.0015	-	0.04	2
N	84		84		3

Rev. 0 2/21/95

NOTES:

1. Index area: A notch or a pin one identification mark shall be located adjacent to pin one and shall be located within the shaded area shown. The manufacturer's identification shall not be used as a pin one identification mark.
2. Dimensions b1 and c1 apply to lead base metal only. Dimension M applies to lead plating and finish thickness. The maximum limits of lead dimensions b and c or M shall be measured at the centroid of the finished lead surfaces, when solder dip or tin plate lead finish is applied.
3. N is the maximum number of terminal positions.
4. Measure dimension e1 at all four corners.
5. For bottom-brazed lead packages, no organic or polymeric materials shall be molded to the bottom of the package to cover the leads.
6. Dimension Q shall be measured at the point of exit (beyond the meniscus) of the lead from the body. Dimension Q minimum shall be reduced by 0.0015 inch (0.038mm) maximum when solder dip lead finish is applied.
7. Dimensioning and tolerancing per ANSI Y14.5M - 1982.
8. Controlling dimension: Inch.