

ISS		ZDNE		REVISIONS		DESCRIPTION\PER REQUEST\DATE	

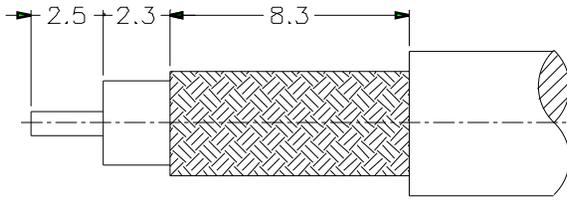

RECOMMENDED
CABLE STRIPPING DIM'S

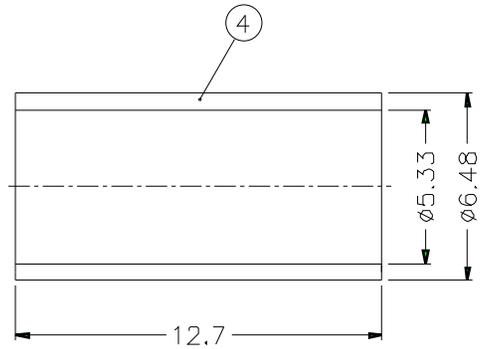
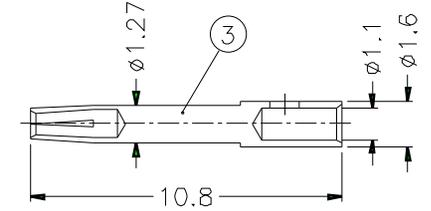
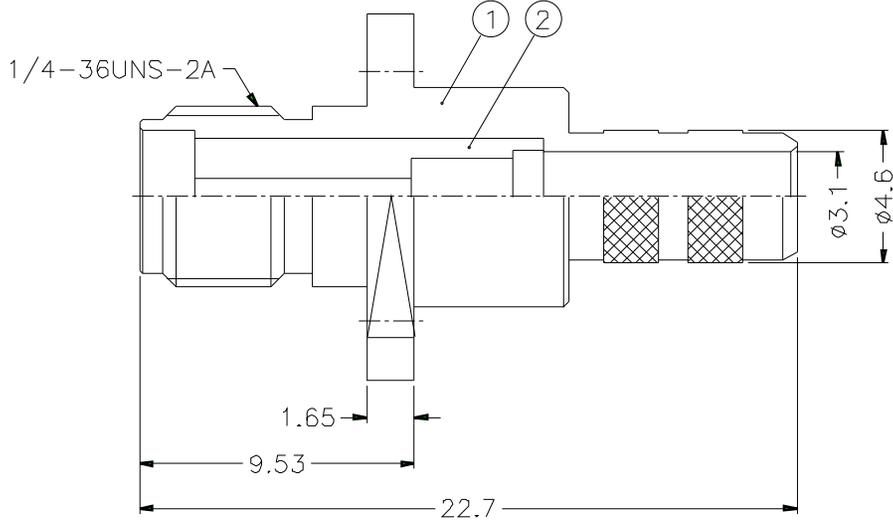
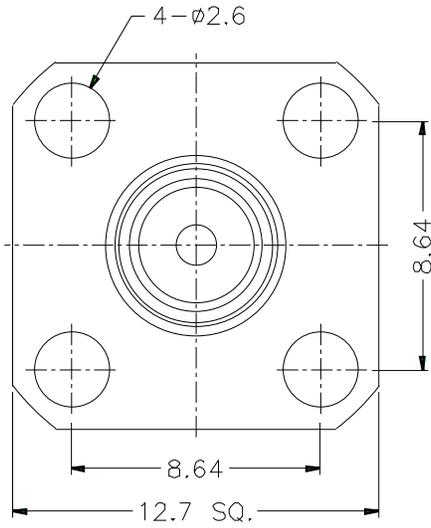

- NOTES: FINISH (PLATING THICKNESS IN MICRO-INCHES)
1. BRASS PER QQ-B-626
 2. GOLD PL. 3 MIN. THICK OVER NICKEL PL. 100 MIN. THICK OVER COPPER STRIKE
 3. BERYLLIUM COPPER PER QQ-C-530
 4. GOLD PL. 50 MIN. THICK OVER NICKEL PL. 100 MIN. THICK OVER COPPER STRIKE
 5. TEFLON MIL-P-19468

1. CRIMPED FERRULE
HEX CRIMP SIZE .213"
2. CONTACT PIN TO SOLDER

DIMENSIONS ARE IN MILLIMETERS						PART NO. SMA6511A1-3GT50G-1-50		<h1 style="text-align: center;">Amphenol</h1> <p style="text-align: center;">TITLE SMA PANEL CRIMP JACK</p> <p style="text-align: center;">DRAWING NO. KJ-SMA6511A1-3GT50G-58U-50</p> <p style="text-align: center;">ITEM NO.</p>			
4	FERRULE	COPPER	NOTE 2	1	FR-648/533X 127C	UNLESS OTHERWISE SPECIFIED TOLERANCES				APPROVED	DATE
3	CONTACT PIN	NOTE 3	NOTE 4	1	SMA7000-3-16/ 11	0.5-6 = ±0.2	6-30 = ±0.4			CHECKED	DATE
2	INSULATOR	NOTE 5	NATURAL	1	SMA7000-2T-50	30-120 = ±0.6	120-315 = ±1			DRAWN	DATE
1	BODY	NOTE 1	NOTE 2	1	SMA6511A1-1-46 /31-B	315-1000 = ±1.6	1000-2000 = ±2.4				
NO.	DESCRIPTION	MATERIAL	FINISH	Q'TY	DRAWING NO.	SCALE	4/1	ISSUE	A	FILE NO.	