

Typical unit

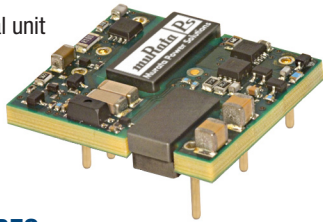

## FEATURES

- Small footprint DC/DC converter, ideal for high current applications
- Industry standard 0.96" x 1.1" X 0.32" open frame package and pinout
- Wide range input voltages 9-36 and 18-75 Vdc
- Assembly and attachment for RoHS standards
- Isolation up to 2250 VDC (basic)
- Up to 15 Watts or greater total output power with overtemperature shutdown
- High efficiency synchronous rectifier forward topology
- Stable operation with no required external components
- Usable -40 to 85°C temperature range (with derating)
- Certified to UL 60950-1, CAN/CSA-C22.2 No. 60950-1, IEC60950-1, EN60950-1 safety approvals, 2nd edition
- Extensive self-protection shut down features

## PRODUCT OVERVIEW

Wide range 4:1 inputs on the 0.96" x 1.1" x 0.32" converter are either 9 to 36 Volts DC (Q12 models) or 18 to 75 Volts DC (Q48 models), ideal for battery-powered and telecom equipment. The industry-standard pinout fits larger 1" x 2" converters. Fixed output voltages from 3.3 VDC to 15 VDC are regulated to within  $\pm 0.2\%$  or less and may be trimmed within  $\pm 10\%$  of nominal output. Applications include small instruments, area-limited microcontrollers, computer-based systems, data communications equipment, remote sensor systems, vehicle and portable electronics.

The UEI 15W series includes full magnetic and optical isolation up to 2250 Volts DC (basic insulation). For connection to digital systems, the outputs offer fast settling to current step loads and tolerance of higher capacitive loads. Excellent ripple

and noise specifications assure compatibility to circuits using CPU's, ASIC's, programmable logic and FPGA's. For systems requiring controlled startup/shutdown, an external switch, transistor or digital logic may be used to activate the remote On/Off control.

A wealth of self-protection features avoid both converter and external circuit problems. These include input undervoltage lockout and overtemperature shutdown. The outputs current limit using the "hiccup" autorestart technique and the outputs may be short-circuited indefinitely. Additional features include output overvoltage and reverse conduction elimination.

The high efficiency offers minimal heat buildup and "no fan" operation.

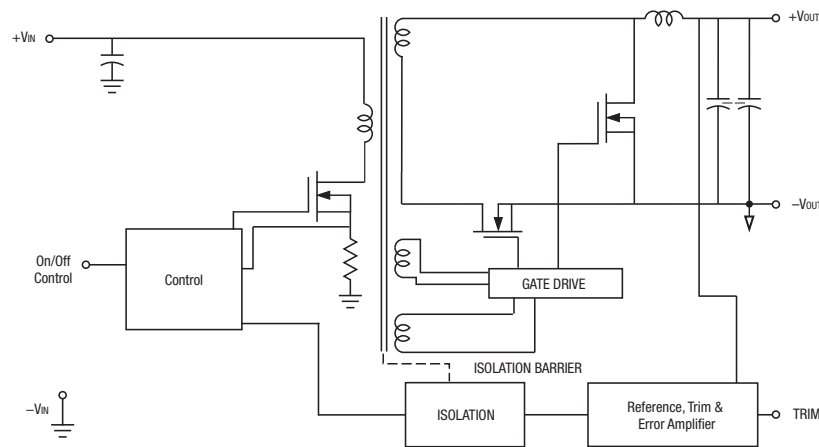

Figure 1. Simplified block diagram—3.3V and 5V<sub>out</sub> models only. Typical topology is shown.



PERFORMANCE SPECIFICATIONS AND ORDERING GUIDE ①																
Root Models ①	Output						Input				Efficiency		Open Frame Package – C75			
	V <sub>OUT</sub> (V)	I <sub>OUT</sub> (A)③	Power (W)	R/N (mVp-p) ②		Regulation (Max.)		V <sub>IN</sub> Nom. (V)	Range (V)	I <sub>IN</sub> = no load (mA)	I <sub>IN</sub> = full load (A)	Min.	Typ.	(inches)	(mm)	Case Pinout
				Typ.	Max.	Line	Load									
UEI15-033-Q12	3.3	4.5	14.85	60	90	±0.05%	±0.1%	24	9-36	43	0.71	86.5%	89%	1.1×0.96×0.32	27.9×24.4×8.1	P85
UEI15-033-Q48	3.3	5	16.5	60	90	±0.2%	±0.2%	48	18-75	24	0.4	85.5%	88%			
UEI15-050-Q12	5	3	15	70	125	±0.05%	±0.075%	24	9-36	41	0.72	86.3%	87.3%			
UEI15-050-Q48	5	3	15	60	95	±0.05%	±0.06%	48	18-75	28	0.36	84.3%	86.0%			
UEI15-120-Q12	12	1.3	15.6	110	150	±0.05%	±0.05%	24	9-36	15	0.77	82.3%	84.5%			
UEI15-120-Q48	12	1.3	15.6	85	120	±0.075%	±0.05%	48	18-75	15	0.38	83.3%	85%			
UEI15-150-Q12	15	1.1	16.5	130	175	±0.05%	±0.05%	24	9-36	18	0.81	83.5%	85%			
UEI15-150-Q48	15	1.1	16.5	80	120	±0.05%	±0.05%	48	18-75	14	0.4	83.3%	85.3%			

① Please refer to the part number structure for additional options and complete ordering part numbers.

② All specifications are typical at nominal line voltage and full load, +25 deg.C. unless otherwise noted. See detailed specifications.

③ Minimum output load for all models is 10% of maximum current.

④ RoHS-6 compliance does not claim EU RoHS exemption 7b (lead in solder).

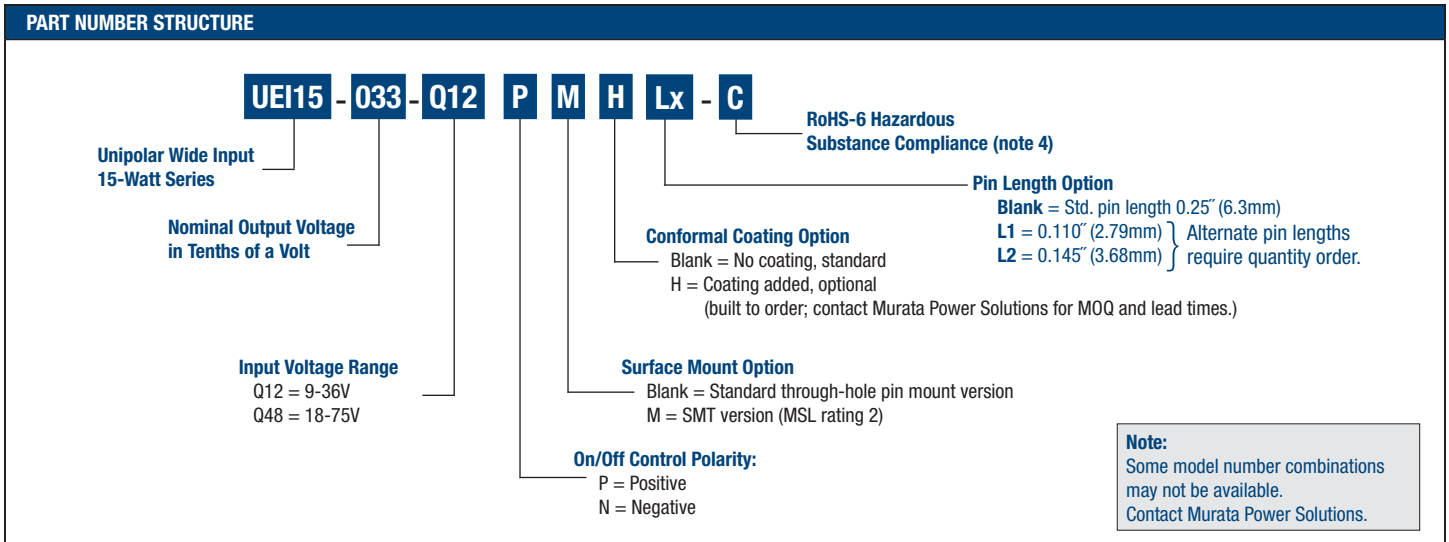

**SPECIAL MODEL NUMBERS:**

UEI-31204-C, Restricted AVL and surface mount

INPUT CHARACTERISTICS														
Model Family	Start-up threshold V	Under-voltage Shut-down V	Reflected (back) Ripple Current mA pk-pk	Input Current					Recommended Fast-blow Fuse A	Internal Input Filter Type	Reverse Polarity Protection	Remote On/Off Control		
				Inrush Transient A <sup>2</sup> sec	Min. Load mA	Output Short Circuit mA	Low Line A	Standby Mode mA				On/Off Current mA	Positive Logic blank model suffix	Negative Logic "N" model suffix
UEI15-033-Q12	9.1 <sup>®</sup>	8.6	30	0.05	100	50	1.86	1	4	C	None. Install external fuse. See note 15.	1	OFF=Gnd pin or -0.7 to +0.7V max. ON=open pin or +10 to +15V max.	OFF=open pin or +10 to +15V max. ON=Gnd pin or -0.7 to +0.8V max.
UEI15-033-Q48	16.7	15.6			65		1.03		2					
UEI15-050-Q12	9.5	8.5			105		1.90		4					
UEI15-050-Q48	16.7	15.6			60		0.96		2	L				
UEI15-120-Q12	9.5	8.4			110		2.04		4					
UEI15-120-Q48	16.7	15.6			56		1.02		1.5					
UEI15-150-Q12	9.5	8.4			130		2.13		4	C				
UEI15-150-Q48	16.7	16.2			60		1.06		2					

OUTPUT CHARACTERISTICS											
Model Family	I <sub>out</sub> <sup>®</sup> Max. mA	V <sub>out</sub> Accuracy 50% Load % of V <sub>NOM</sub>	Adjustment Range % of V <sub>NOM</sub>	Temperature Coefficient % of V <sub>out</sub> /°C	Capacitive Loading Max. Low ESR <0.02Ω Max, μF	Overvoltage protection V	OV protection method	Voltage Output range	Ripple/Noise (20 MHz bandwidth) <sup>®</sup>	Line/Load Regulation	Efficiency
UEI15-033-Q12	See Ordering Guide (Minimum load is 10% of I <sub>max</sub> )	±1	±10 <sup>®</sup>	±0.02	1,000	4.5	Magnetic feedback	See ordering guide			
UEI15-033-Q48						3.9					
UEI15-050-Q12						5.9					
UEI15-050-Q48						5.9					
UEI15-120-Q12					470	14.1					
UEI15-120-Q48					15						
UEI15-150-Q12					19.5						
UEI15-150-Q48					20						

ISOLATION CHARACTERISTICS				
Model Family	Input to Output Min. Vdc	Isolation Resistance Min. MΩ	Isolation Capacitance pF	Isolation Safety Rating
UEI15-033-Q12	2000	10	1000	Basic insulation
UEI15-033-Q48	2250	10	1500	
UEI15-050-Q12	2000	10	1500	
UEI15-050-Q48	2250	10	1000	
UEI15-120-Q12	2000	10	1000	
UEI15-120-Q48	2250	10	1000	
UEI15-150-Q12	2000	10	1500	
UEI15-150-Q48	2250	10	1000	

DYNAMIC CHARACTERISTICS					
Model Family	Dynamic Load Response (50-75-50% load step) μSec to 1% V <sub>out</sub> <sup>①</sup>	Peak Deviation mV	Start-up Time		Switching Frequency KHz
			V <sub>in</sub> to V <sub>out</sub> regulated (Max.) mSec	Remote On/Off to V <sub>out</sub> regulated max.) mSec	
UEI15-033-Q12	150	±125	50	50	350
UEI15-033-Q48	100	±35			350
UEI15-050-Q12		±60			350
UEI15-050-Q48	±30	375			
UEI15-120-Q12	150	±150			340
UEI15-120-Q48	100	±200			350
UEI15-150-Q12		±125			340
UEI15-150-Q48		±175			380

MISCELLANEOUS CHARACTERISTICS											
Model Family	Current Limit Inception 98% of V <sub>out</sub> , after warmup A	Short Circuit Protection Method	Short Circuit Current A	Short Circuit Duration (output shorted to ground) <sup>①</sup>	Pre-biased setup	Calculated MTBF Hours <sup>④</sup>	Operating Temperature Range		Storage Temperature Range °C	Thermal protection/shutdown °C	
							See Derating Curves				
UEI15-033-Q12	6.0	Current limiting, hiccup autorestart	0.3	Continuous	Monotonic	2 x 10 <sup>6</sup>	-40 to +85°C		-55 to +125 °C	115	
UEI15-033-Q48	7.2					3.49 x 10 <sup>6</sup>					
UEI15-050-Q12	4.6					2 x 10 <sup>6</sup>					
UEI15-050-Q48	4.5										
UEI15-120-Q12	2.0										
UEI15-120-Q48	1.8					4.1 x 10 <sup>6</sup>					135
UEI15-150-Q12	1.6					2.1 x 10 <sup>6</sup>					
UEI15-150-Q48	1.7					2 x 10 <sup>6</sup>					

① Remove overload for recovery.



ABSOLUTE MAXIMUM RATINGS			
Input Voltage	Q12 models	Volts Max. continuous	36 VDC
		Volts, transient 100mS	50 VDC
	Q48 models	Volts Max. continuous	75 VDC
		Volts, transient 100mS	100 VDC
On/Off control, referred to $-V_{IN}$		Volts, Min.	-0.3
		Volts, Max.	15
Input Reverse Polarity Protection			See fuse section
Output Overvoltage, Volts Max.			$V_{OUT\ nom.} +20\%$
Output Current, sustained short circuit			Current-limited, see specs
Storage Temperature	Range, Min. °C		-55
	Max. °C		+125

### Absolute Maximum Ratings

Absolute maximums are stress ratings. Exposure of devices to greater than any of these conditions may adversely affect long-term reliability. Proper operation under conditions other than those listed in the Performance/Functional Specifications is neither implied nor recommended.

### SPECIFICATION NOTES

(1) All models are tested and specified with external capacitors listed in the table below. The external capacitors listed below are ONLY for establishing test specifications. They are required for our test fixtures and equipment. Your application may not need them. The converter is stable with no external capacitors but Murata Power Solutions strongly recommends external caps. All caps are low-ESR types. Where two or more capacitors are listed, these are connected in parallel. All caps should mount close to the DC/DC using short leads.

All specifications are typical unless noted. General conditions for Specifications are +25 deg.C,  $V_{IN}$ =nominal,  $V_{OUT}$ =nominal, full load. Adequate airflow must be supplied for extended testing under power.

(2) Input Ripple Current is tested and specified over a 5 Hz to 20 MHz bandwidth. Input filtering is  $C_{IN}$ =33  $\mu$ F, 100V tantalum,  $C_{BUS}$ =220  $\mu$ F, 100V electrolytic,  $L_{BUS}$ =12  $\mu$ H.

(3) Note that Maximum Power Derating curves indicate an average current at nominal input voltage. At higher temperatures and/or lower airflow, the DC/DC converter will tolerate brief full current outputs if the total RMS current over time does not exceed the Derating curve. All Derating curves are presented at sea level altitude. Be aware of reduced power dissipation with increasing density altitude.

INPUT/OUTPUT EXTERNAL TEST CAPACITORS		
Model	Input Capacitor	Output Capacitor(s)
UEI15-033-Q12	100 $\mu$ F	1 $\mu$ F & 10 $\mu$ F
UEI15-033-Q48	4.7 $\mu$ F ceramic	1 $\mu$ F & 10 $\mu$ F
UEI15-050-Q12	100 $\mu$ F	1 $\mu$ F & 10 $\mu$ F
UEI15-050-Q48	4.7 $\mu$ F ceramic	1 $\mu$ F & 10 $\mu$ F
UEI15-120-Q12	100 $\mu$ F	1 $\mu$ F & 10 $\mu$ F
UEI15-120-Q48	4.7 $\mu$ F ceramic	1 $\mu$ F & 10 $\mu$ F
UEI15-150-Q12	100 $\mu$ F	1 $\mu$ F & 10 $\mu$ F
UEI15-150-Q48	4.7 $\mu$ F ceramic	1 $\mu$ F & 10 $\mu$ F

(4) Mean Time Before Failure is calculated using the Telcordia (Belcore) SR-332 Method 1, Case 3, ground fixed conditions, Tpcboard=+25 deg.C, full load, natural air convection.

(5) The On/Off Control is normally controlled by a switch. But it may also be driven with external logic or by applying appropriate external voltages which are referenced to Input Common. The On/Off Control Input should use either an open collector or open drain transistor.

(6) Output current limiting begins when the output voltage degrades approximately 2% from the selected setting.

(7) The outputs are not intended to sink appreciable reverse current. This may damage the outputs.

(8) Output noise may be further reduced by adding an external filter. See I/O Filtering and Noise Reduction.

(9) All models are fully operational and meet published specifications, including "cold start" at -40°C.

(10) Regulation specifications describe the deviation as the line input voltage or output load current is varied from a nominal midpoint value to either extreme.

(11) The output overvoltage protection is automatic recovery after fault removal. The overvoltage may occur either from internal failure or from an external forcing voltage as in a shared power system.

(12) Output current limit and short circuit protection is non-latching. When the overcurrent fault is removed, the converter will immediately recover.

(13) Do not exceed maximum power specifications when adjusting the output trim.

(14) At zero output current, the output may contain low frequency components which exceed the ripple specification. The output may be operated indefinitely with no load.

(15) If reverse polarity is accidentally applied to the input, to ensure reverse input protection with full output load, always connect an external input **fuse** in series with the + $V_{IN}$  input. Use approximately twice the full input current rating with nominal input voltage.

(16) "Hiccup" operation repeatedly attempts to restart the converter with a brief, full-current output. If the overcurrent condition still exists, the restart current will be removed and then tried again. This short current pulse prevents overheating and damaging the converter. Once the fault is removed, the converter immediately recovers normal operation.

(17) On model UEI15-050-Q48, if  $V_{IN} < 20V$ , output trim may only be adjusted downwards from +5.0V (more negative).

(18) Shown at  $V_{in} = 10V$ .

**CAUTION:** This product is not internally fused. To comply with safety agency certifications and to avoid injury to personnel or equipment, the user **must** connect an external fast-blow fuse to the input terminals. See fuse information.

(19) All models require 10% of  $I_{max}$  minimum output load to meet specifications. However, they will not be damaged at zero output load.

**MECHANICAL SPECIFICATIONS, OPEN FRAME**

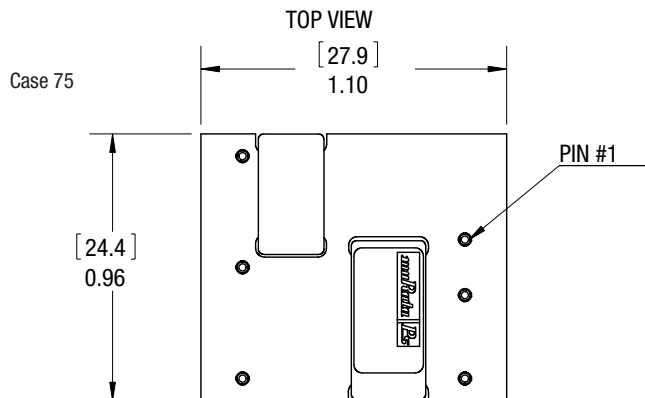

PHYSICAL CHARACTERISTICS	
Pin Material	Copper alloy
Pin Diameter	0.04" (1.016mm)
Pin Finish	Gold plate
Weight	0.352 oz./10 grams
Electromagnetic Interference	EN55022/CISPR22 (see note 1) (Requires external filter)
Flammability Rating	UL 94V-0
Safety	Certified to UL/cUL 60950-1, CAN/CSA-C22.2-60950-1, IEC/EN 60950-1, 2nd edition

Dimensions are in inches (mm shown for ref. only).

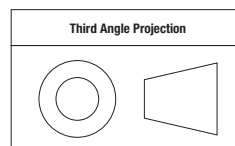

Tolerances (unless otherwise specified):  
 .XX ± 0.02 (0.5)  
 .XXX ± 0.010 (0.25)  
 Angles ± 1°

Components are shown for reference only.

INPUT/OUTPUT CONNECTIONS	
Pin	Function P85
1	Positive Vin
2	Negative Vin
3	Positive Vout
4	Output Trim
5	Negative Vout
6	On/Off Control*

\*The Remote On/Off can be provided with either positive (P suffix) or negative (N suffix) polarity

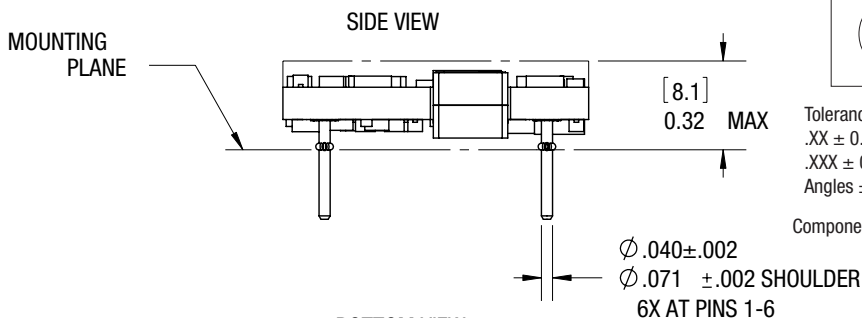

**BOTTOM VIEW**

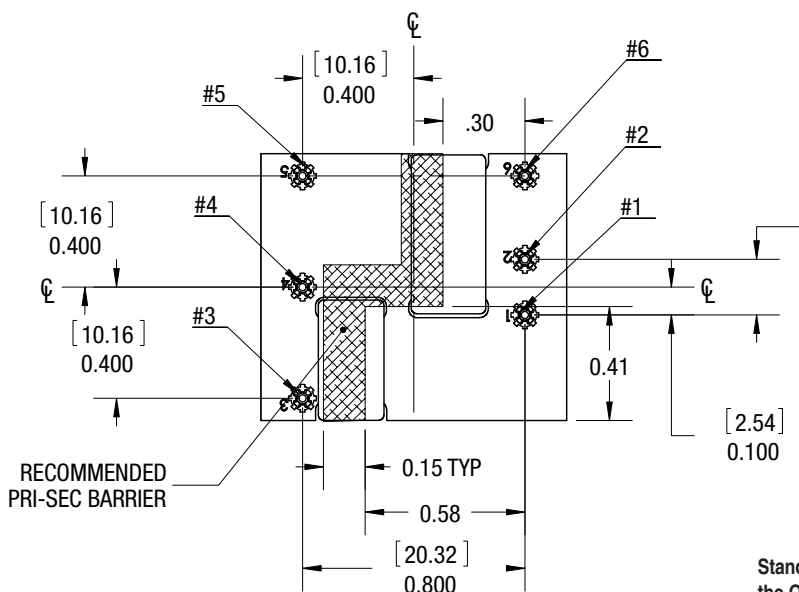

**END VIEW**

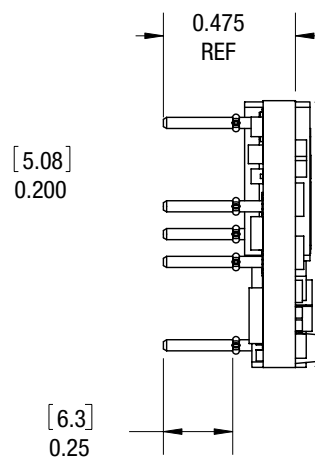

Standard pin length is shown. Please refer to the Ordering Guide for alternate pin lengths.

**SHIPPING TRAYS AND BOXES, THROUGH-HOLE MOUNT**

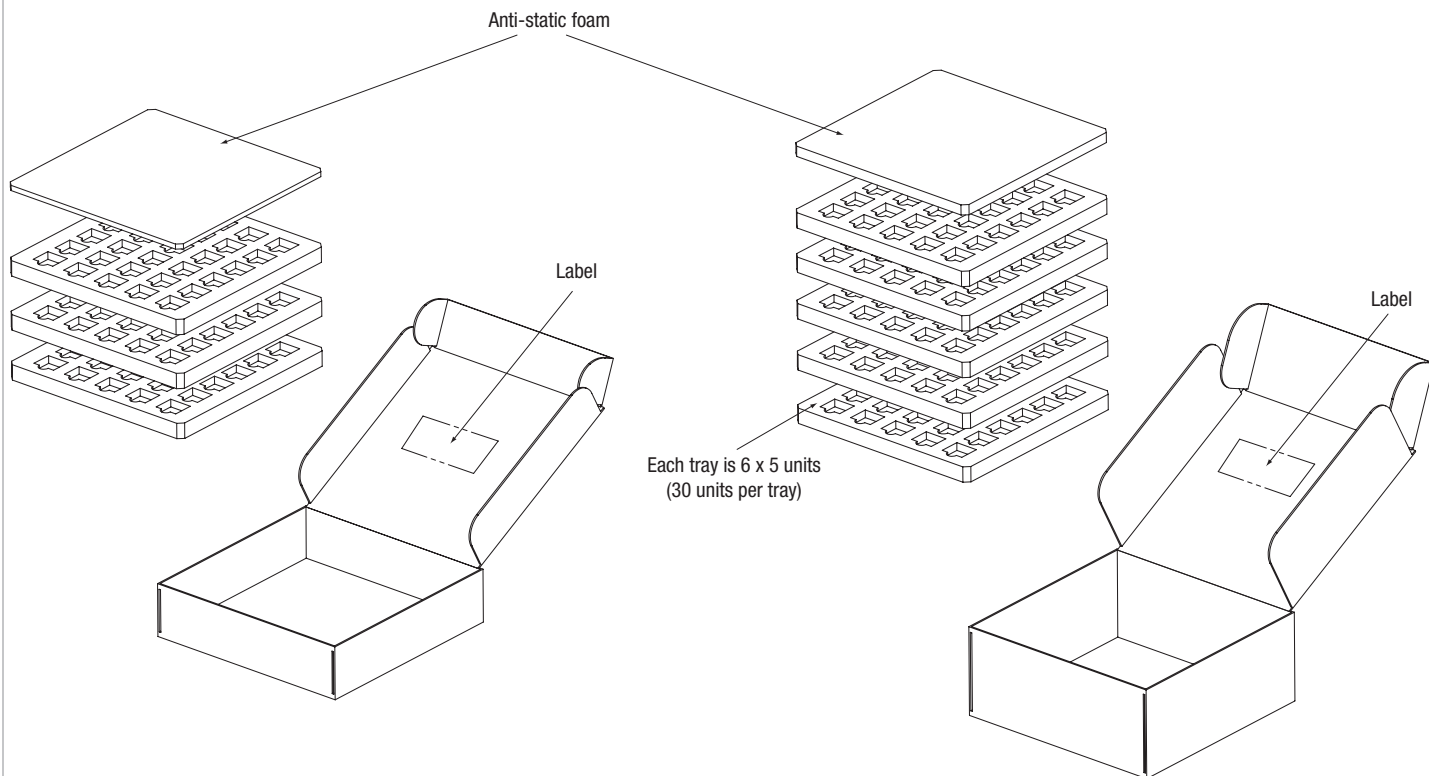

**SHIPPING TRAY DIMENSIONS**

UEI modules are supplied in a 30-piece (6 x 5) shipping tray. The tray is an anti-static closed-cell polyethylene foam. Dimensions are shown below.

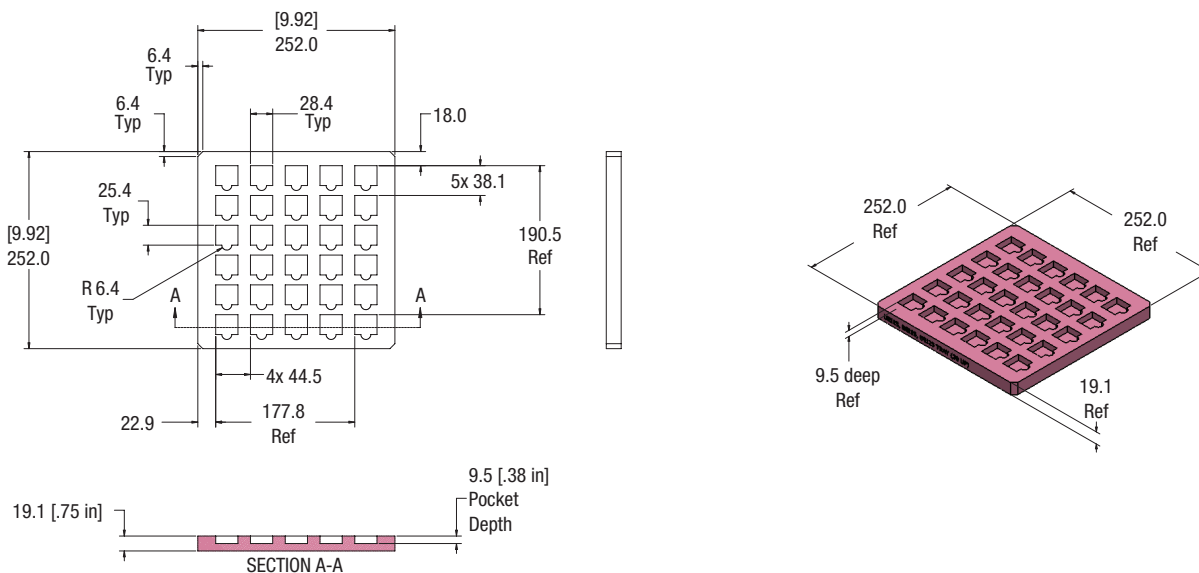

**Notes:**

1. Material: Dow 220 antistat ethafoam (Density: 34-35 kg/m<sup>3</sup>)
2. Dimensions: 252 x 252 x 19.1 mm  
6 x 5 array (30 per tray)
3. All dimensions in millimeters [inches]
4. Tolerances unless otherwise specified: +1/-0

**MECHANICAL SPECIFICATIONS, SURFACE MOUNT PACKAGE (MSL RATING 2)**

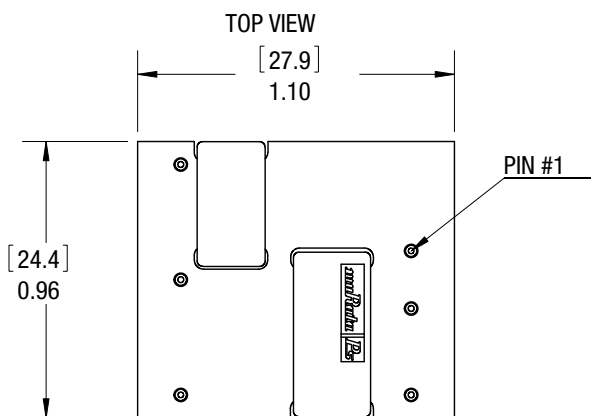

Dimensions are in inches (mm shown for ref. only).

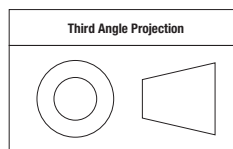

Tolerances (unless otherwise specified):  
 .XX ± 0.02 (0.5)  
 .XXX ± 0.010 (0.25)  
 Angles ± 1°

Components are shown for reference only.

INPUT/OUTPUT CONNECTIONS	
Pin	Function
1	Positive Vin
2	Negative Vin
3	Positive Vout
4	Output Trim
5	Negative Vout
6	On/Off Control*

\*The Remote On/Off can be provided with either positive (P suffix) or negative (N suffix) polarity

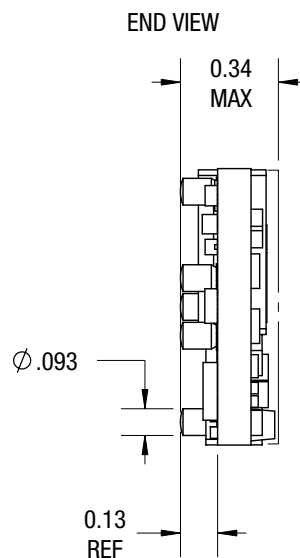
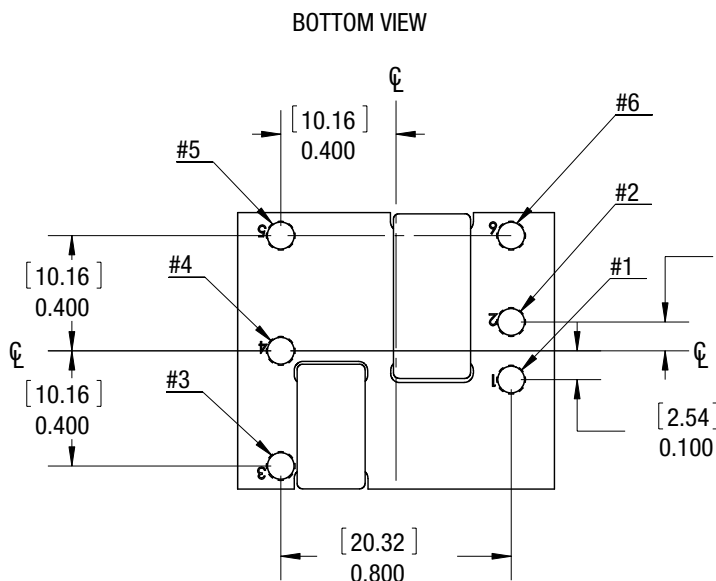
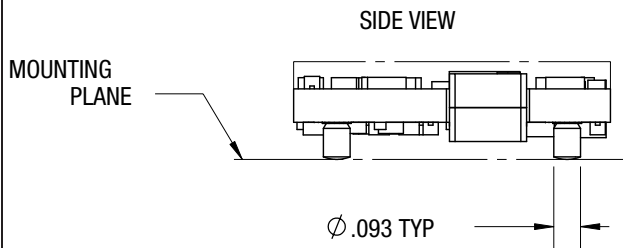

**MECHANICAL SPECIFICATIONS, SURFACE MOUNT PACKAGE**

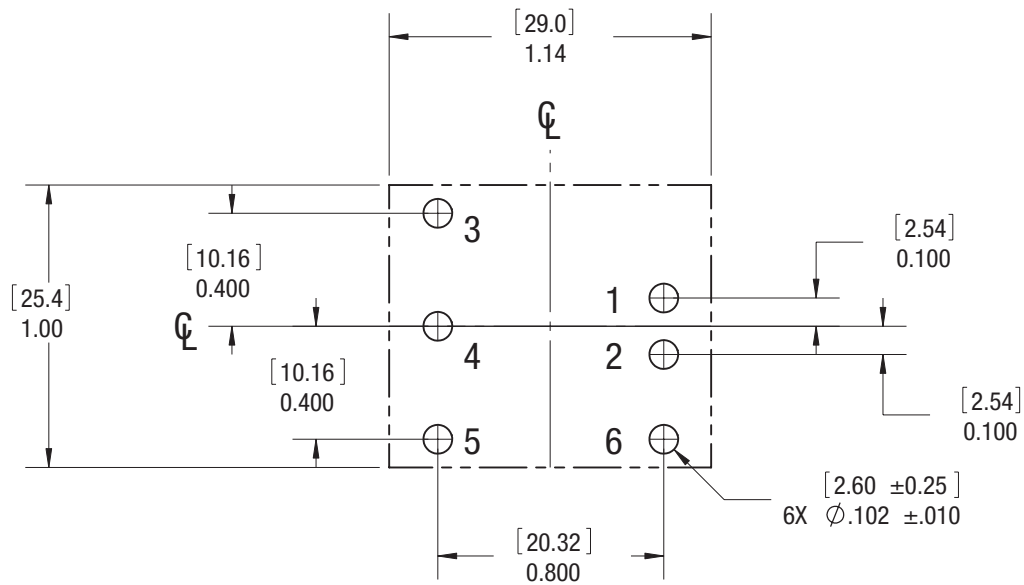

RECOMMENDED SMT PAD LAYOUT

**SURFACE MOUNT TAPE AND REEL INFORMATION (MSL RATING 2)**



**NOTE: The SMT package has an MSL 2 rating.**

PACKAGING CONFORMS TO EIA-481  
CONVERTERS SHIPPING IN QUANTITIES  
OF 100 PER REEL

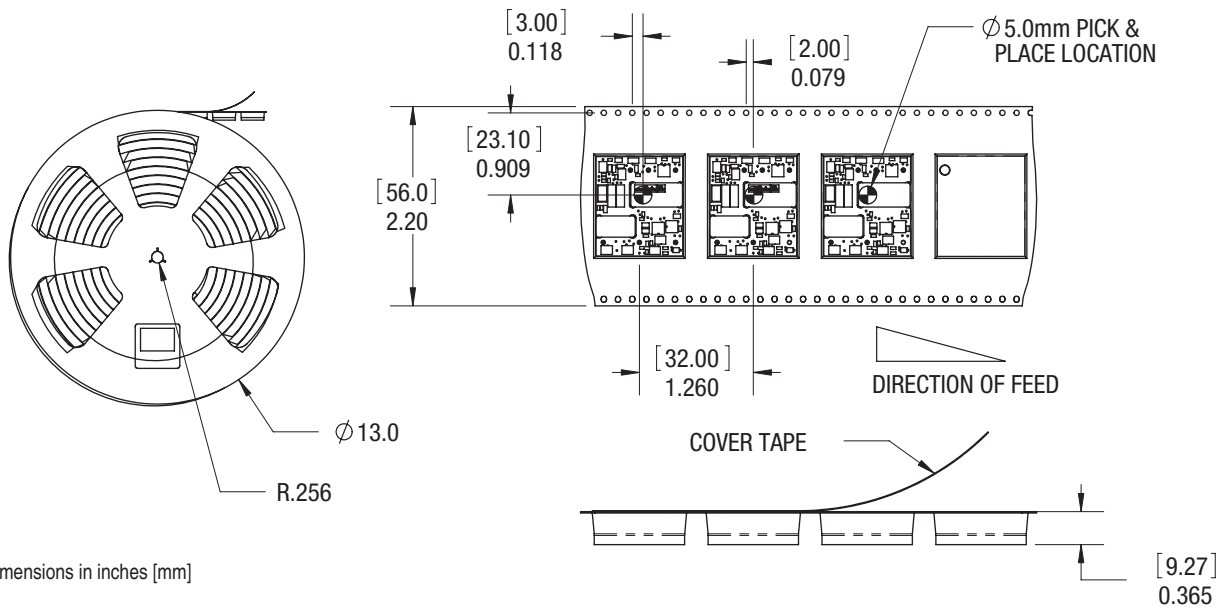

Dimensions in inches [mm]

SURFACE MOUNT TAPE AND REEL



**PERFORMANCE DATA**

**UEI15-033-Q12**

Efficiency vs. Line Voltage and Load Current @ 25°C

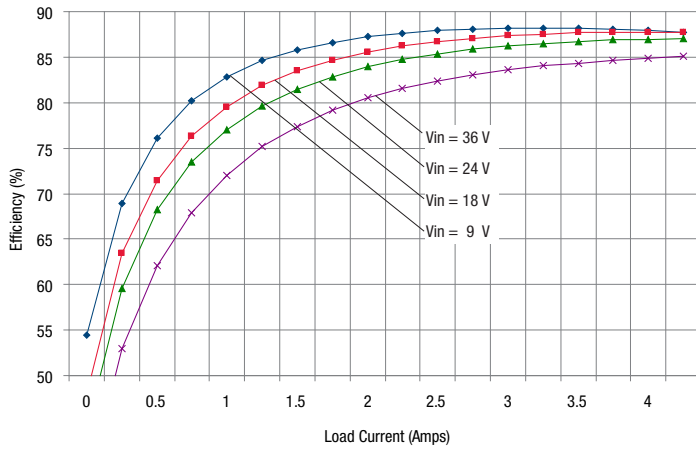

Maximum Current Temperature Derating @sea level  
(VIN = 12V or 24V, airflow from input to output)

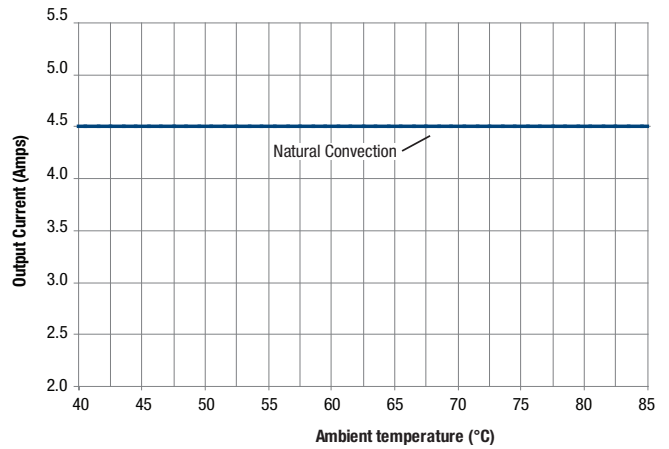

**UEI15-033-Q48**

Efficiency vs. Line Voltage and Load Current @ 25°C

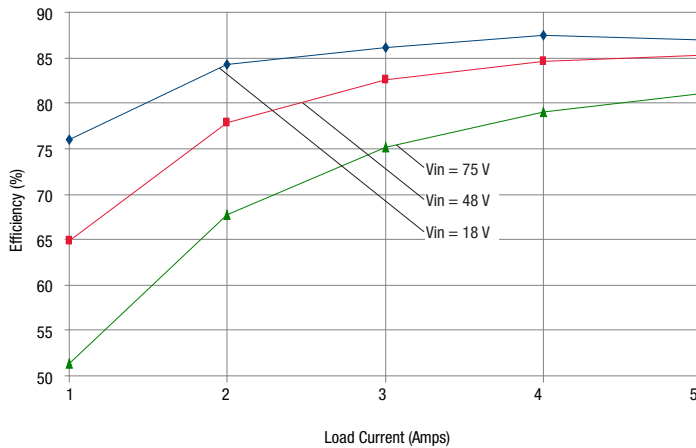

Maximum Current Temperature Derating @sea level  
(VIN = 24V, airflow from input to output)

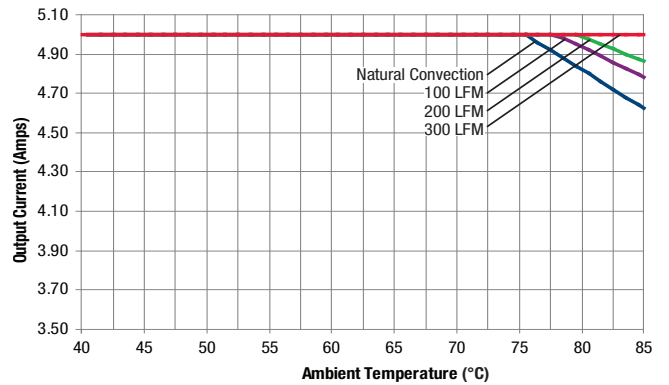

**UEI15-033-Q48**

Maximum Current Temperature Derating @sea level  
(VIN = 48V, airflow from input to output)

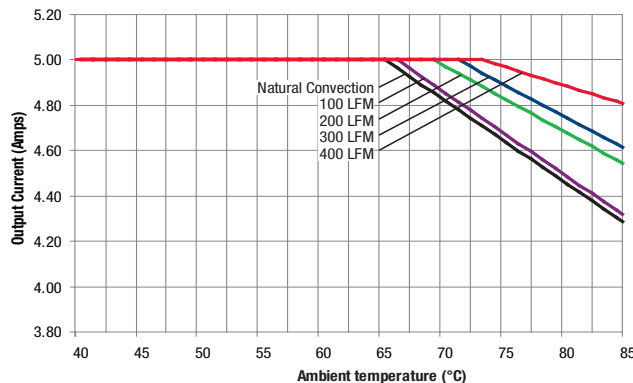

## PERFORMANCE DATA

### UEI15-050-Q12

Efficiency vs. Line Voltage and Load Current @ 25°C

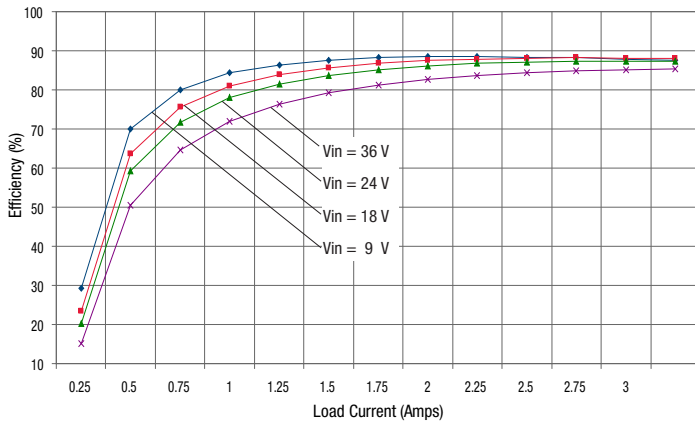

Maximum Current Temperature Derating @Sea Level  
(Vin = 24V, airflow is from pin 1 to pin 3)

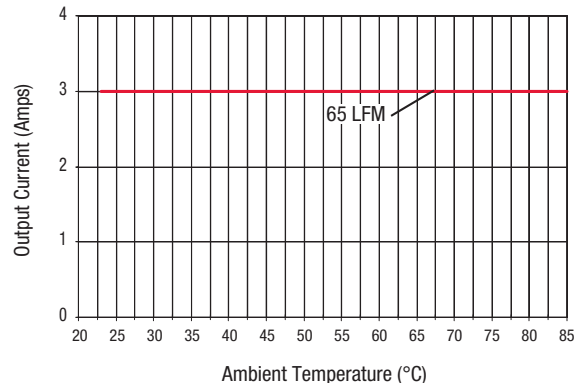

### UEI15-050-Q48

Efficiency vs. Line Voltage and Load Current @ 25°C

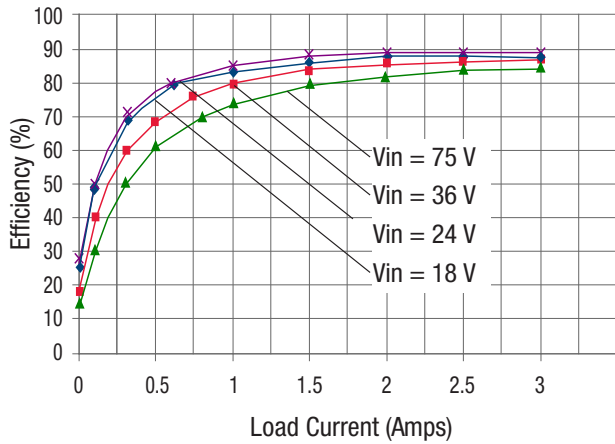

Maximum Current Temperature Derating @Sea Level  
(Vin = 24V or 48V, airflow is from input to output)

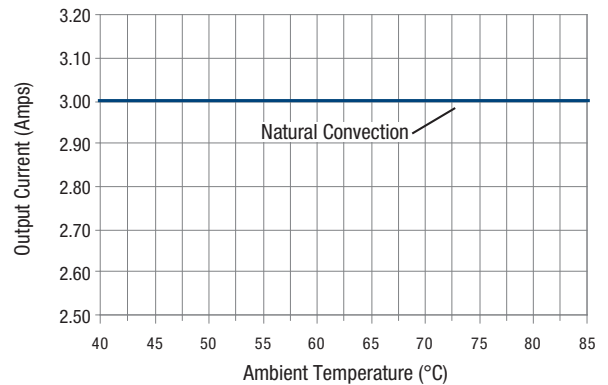

### UEI15-120-Q12

Efficiency vs. Line Voltage and Load Current @ 25°C

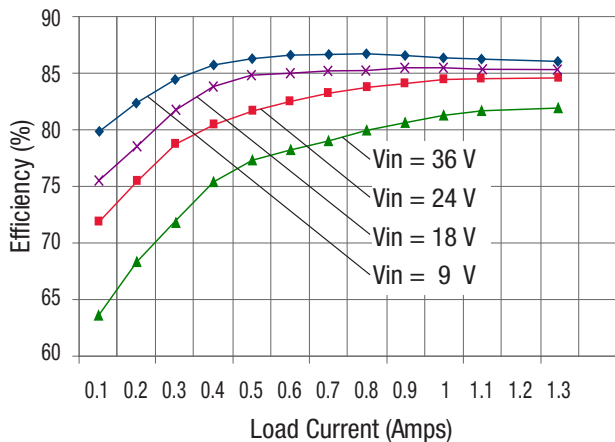

Maximum Current Temperature Derating @Sea Level  
(Vin = 24V, airflow is from pin 1 to pin 3)

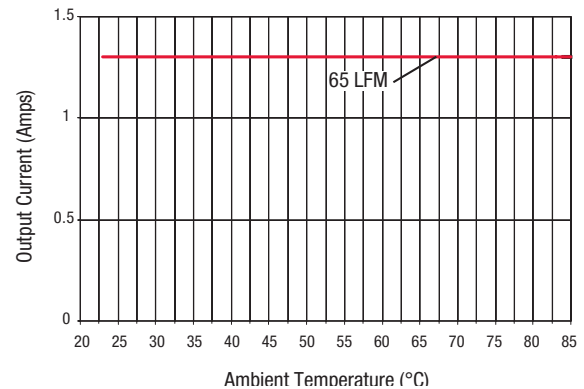

## PERFORMANCE DATA

### UEI15-120-Q48

Efficiency vs. Line Voltage and Load Current @ 25°C

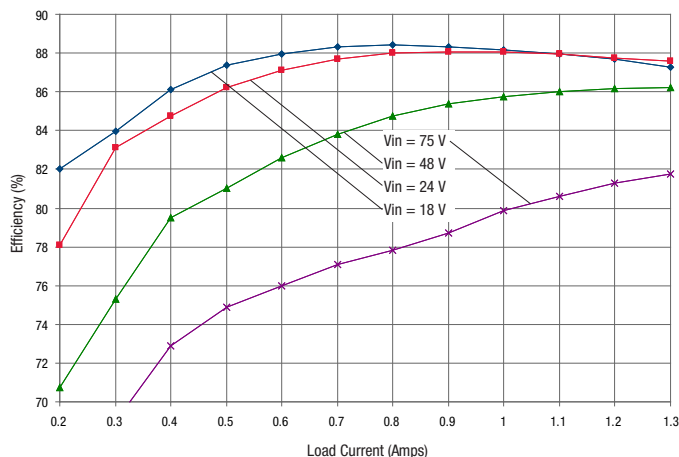

Maximum Current Temperature Derating @Sea Level  
( $V_{IN} = 24V$  or  $48V$ , airflow is from pin 2 to pin 1)

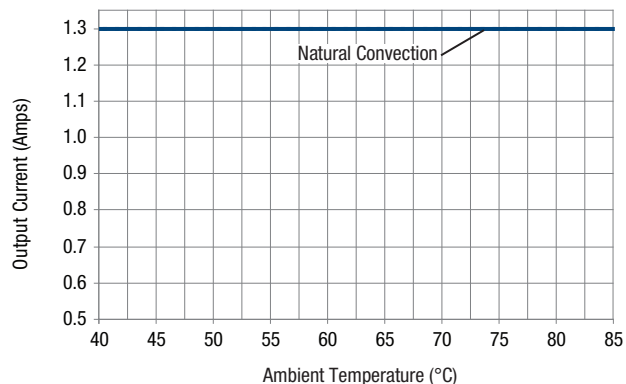

### UEI15-150-Q12

Efficiency vs. Line Voltage and Load Current @ 25°C

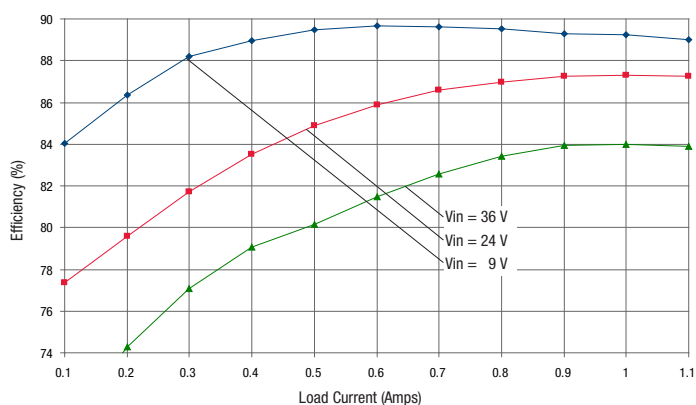

Maximum Current Temperature Derating @Sea Level  
( $V_{IN} = 12V$  and  $24V$ , airflow is from input to output)

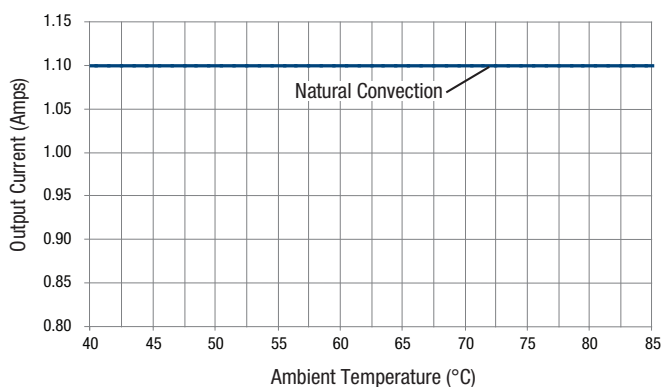

### UEI15-150-Q48

Efficiency vs. Line Voltage and Load Current @ 25°C

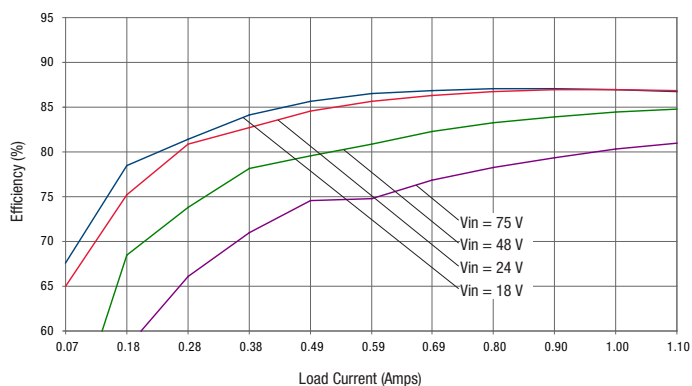

Maximum Current Temperature Derating @Sea Level  
( $V_{IN} = 24V$  and  $48V$ , airflow is from input to output)

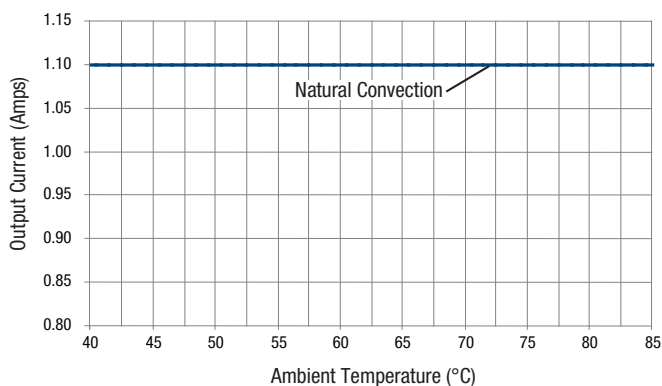

**TECHNICAL NOTES**

**Input Fusing**

Certain applications and/or safety agencies may require fuses at the inputs of power conversion components. Fuses should also be used when there is the possibility of sustained input voltage reversal which is not current-limited. For greatest safety, we recommend a fast blow fuse installed in the ungrounded input supply line.

The installer must observe all relevant safety standards and regulations. For safety agency approvals, install the converter in compliance with the end-user safety standard, i.e. IEC/EN/UL 60950-1.

**Input Reverse-Polarity Protection**

If the input voltage polarity is reversed, an internal diode will become forward biased and likely draw excessive current from the power source. If this source is not current-limited or the circuit appropriately fused, it could cause permanent damage to the converter.

**Input Under-Voltage Shutdown and Start-Up Threshold**

Under normal start-up conditions, converters will not begin to regulate properly until the ramping-up input voltage exceeds and remains at the Start-Up Threshold Voltage (see Specifications). Once operating, converters will not turn off until the input voltage drops below the Under-Voltage Shutdown Limit. Subsequent restart will not occur until the input voltage rises again above the Start-Up Threshold. This built-in hysteresis prevents any unstable on/off operation at a single input voltage.

Users should be aware however of input sources near the Under-Voltage Shutdown whose voltage decays as input current is consumed (such as capacitor inputs), the converter shuts off and then restarts as the external capacitor recharges. Such situations could oscillate. To prevent this, make sure the operating input voltage is well above the UV Shutdown voltage AT ALL TIMES.

**Start-Up Time**

Assuming that the output current is set at the rated maximum, the  $V_{IN}$  to  $V_{OUT}$  Start-Up Time (see Specifications) is the time interval between the point when the ramping input voltage crosses the Start-Up Threshold and the fully loaded regulated output voltage enters and remains within its specified accuracy band. Actual measured times will vary with input source impedance, external input capacitance, input voltage slew rate and final value of the input voltage as it appears at the converter.

These converters include a soft start circuit to moderate the duty cycle of its PWM controller at power up, thereby limiting the input inrush current.

The On/Off Remote Control interval from On command to  $V_{OUT}$  regulated assumes that the converter already has its input voltage stabilized above the Start-Up Threshold before the On command. The interval is measured from the On command until the output enters and remains within its specified accuracy band. The specification assumes that the output is fully loaded at maximum rated current. Similar conditions apply to the On to  $V_{OUT}$  regulated specification such as external load capacitance and soft start circuitry.

**Input Source Impedance**

These converters will operate to specifications without external components, assuming that the source voltage has very low impedance and reasonable input voltage regulation. Since real-world voltage sources have finite impedance,

performance is improved by adding external filter components. Sometimes only a small ceramic capacitor is sufficient. Since it is difficult to totally characterize all applications, some experimentation may be needed. Note that external input capacitors must accept high speed switching currents.

Because of the switching nature of DC/DC converters, the input of these converters must be driven from a source with both low AC impedance and adequate DC input regulation. Performance will degrade with increasing input inductance. Excessive input inductance may inhibit operation. The DC input regulation specifies that the input voltage, once operating, must never degrade below the Shut-Down Threshold under all load conditions. Be sure to use adequate trace sizes and mount components close to the converter.

**I/O Filtering, Input Ripple Current and Output Noise**

All models in this converter series are tested and specified for input reflected ripple current and output noise using designated external input/output components, circuits and layout as shown in the figures below. External input capacitors ( $C_{IN}$  in the figure) serve primarily as energy storage elements, minimizing line voltage variations caused by transient IR drops in the input conductors. Users should select input capacitors for bulk capacitance (at appropriate frequencies), low ESR and high RMS ripple current ratings. In the figure below, the  $C_{bus}$  and  $L_{bus}$  components simulate a typical DC voltage bus. Your specific system configuration may require additional considerations. Please note that the values of  $C_{in}$ ,  $L_{bus}$  and  $C_{bus}$  will vary according to the specific converter model.

In critical applications, output ripple and noise (also referred to as periodic and random deviations or PARD) may be reduced by adding filter elements such as multiple external capacitors. Be sure to calculate component temperature rise from reflected AC current dissipated inside capacitor ESR.

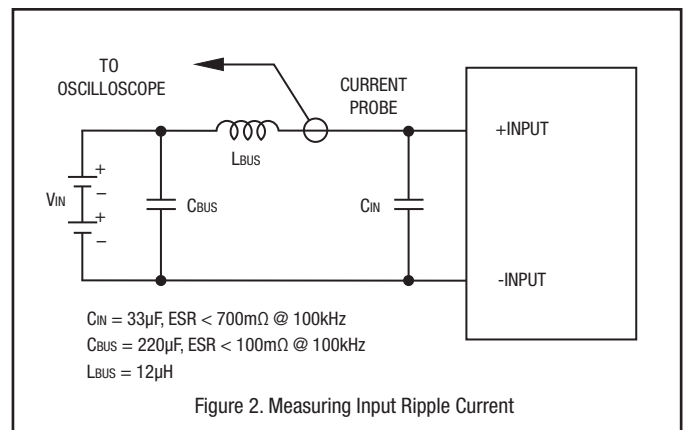

In figure 3, the two copper strips simulate real-world printed circuit impedances between the power supply and its load. In order to minimize circuit errors and standardize tests between units, scope measurements should be made using BNC connectors or the probe ground should not exceed one half inch and soldered directly to the fixture.

**Floating Outputs**

Since these are isolated DC/DC converters, their outputs are “floating” with respect to their input. The essential feature of such isolation is ideal ZERO CURRENT FLOW between input and output. Real-world converters however do exhibit tiny leakage currents between input and output (see Specifications). These leakages consist of both an AC stray capacitance coupling component

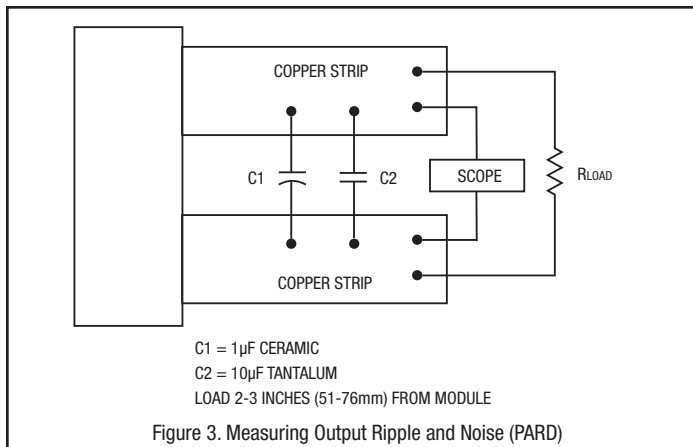

and a DC leakage resistance. When using the isolation feature, do not allow the isolation voltage to exceed specifications. Otherwise the converter may be damaged. Designers will normally use the negative output (-Output) as the ground return of the load circuit. You can however use the positive output (+Output) as the ground return to effectively reverse the output polarity.

**Minimum Output Loading Requirements**

These converters employ a synchronous rectifier design topology. Models UEI15-033-Q12, UEI15-120-Q12, and UEI15-050-Q12 require 10% minimum load to meet specifications. Operation under less than 10% load may slightly increase regulation, ripple, and noise.

**Thermal Shutdown**

To prevent many over temperature problems and damage, these converters include thermal shutdown circuitry. If environmental conditions cause the temperature of the DC/DC's to rise above the Operating Temperature Range up to the shutdown temperature, an on-board electronic temperature sensor will power down the unit. When the temperature decreases below the turn-on threshold, the converter will automatically restart. There is a small amount of hysteresis to prevent rapid on/off cycling.

**CAUTION:** If you operate too close to the thermal limits, the converter may shut down suddenly without warning. Be sure to thoroughly test your application to avoid unplanned thermal shutdown.

**Temperature Derating Curves**

The graphs in the next section illustrate typical operation under a variety of conditions. The Derating curves show the maximum continuous ambient air temperature and decreasing maximum output current which is acceptable under increasing forced airflow measured in Linear Feet per Minute (“LFM”). Note that these are AVERAGE measurements. The converter will accept brief increases in temperature and/or current or reduced airflow as long as the average is not exceeded.

Note that the temperatures are of the ambient airflow, not the converter itself which is obviously running at higher temperature than the outside air. Also note that “natural convection” is defined as very low flow rates which are not using fan-forced airflow. Depending on the application, “natural convection” is usually about 30-65 LFM but is not equal to still air (0 LFM).

MPS makes Characterization measurements in a closed cycle wind tunnel with calibrated airflow. We use both thermocouples and an infrared camera system to observe thermal performance. As a practical matter, it is quite difficult to insert an anemometer to precisely measure airflow in most applications. Sometimes it is possible to estimate the effective airflow if you thoroughly understand the enclosure geometry, entry/exit orifice areas and the fan flowrate specifications. If in doubt, contact MPS to discuss placement and measurement techniques of suggested temperature sensors.

**CAUTION:** If you routinely or accidentally exceed these Derating guidelines, the converter may have an unplanned Over Temperature shut down. Also, these graphs are all collected at slightly above Sea Level altitude. Be sure to reduce the derating for higher density altitude.

**Output Overvoltage Protection**

This converter monitors its output voltage for an over-voltage condition using an on-board electronic comparator. The signal is optically coupled to the primary side PWM controller. If the output exceeds OVP limits, the sensing circuit will power down the unit, and the output voltage will decrease. After a time-out period, the PWM will automatically attempt to restart, causing the output voltage to ramp up to its rated value. It is not necessary to power down and reset the converter for the this automatic OVP-recovery restart.

If the fault condition persists and the output voltage climbs to excessive levels, the OVP circuitry will initiate another shutdown cycle. This on/off cycling is referred to as “hiccup” mode. It safely tests full current rated output voltage without damaging the converter.

**Output Fusing**

The converter is extensively protected against current, voltage and temperature extremes. However your output application circuit may need additional protection. In the extremely unlikely event of output circuit failure, excessive voltage could be applied to your circuit. Consider using an appropriate fuse in series with the output.

**Output Current Limiting**

As soon as the output current increases to approximately 125% to 150% of its maximum rated value, the DC/DC converter will enter a current-limiting mode. The output voltage will decrease proportionally with increases in output current, thereby maintaining a somewhat constant power output. This is commonly referred to as power limiting.

Current limiting inception is defined as the point at which full power falls below the rated tolerance. See the Performance/Functional Specifications. Note particularly that the output current may briefly rise above its rated value. This enhances reliability and continued operation of your application. If the output current is too high, the converter will enter the short circuit condition.

**Output Short Circuit Condition**

When a converter is in current-limit mode, the output voltage will drop as the output current demand increases. If the output voltage drops too low, the magnetically coupled voltage used to develop primary side voltages will also drop, thereby shutting down the PWM controller. Following a time-out period, the PWM will restart, causing the output voltage to begin ramping up to its appropriate value. If the short-circuit condition persists, another shutdown cycle will initiate. This on/off cycling is called “hiccup mode”. The hiccup cycling

reduces the average output current, thereby preventing excessive internal temperatures. A short circuit can be tolerated indefinitely.

**Trimming the Output Voltage**

The Trim input to the converter allows the user to adjust the output voltage over the rated trim range (please refer to the Specifications). In the trim equations and circuit diagrams that follow, trim adjustments use either a trimpot or a single fixed resistor connected between the Trim input and either the positive or negative output terminals. (On some converters, an external user-supplied precision DC voltage may also be used for trimming). Trimming resistors should have a low temperature coefficient ( $\pm 100$  ppm/deg.C or less) and be mounted close to the converter. Keep leads short. If the trim function is not used, leave the trim unconnected. With no trim, the converter will exhibit its specified output voltage accuracy.

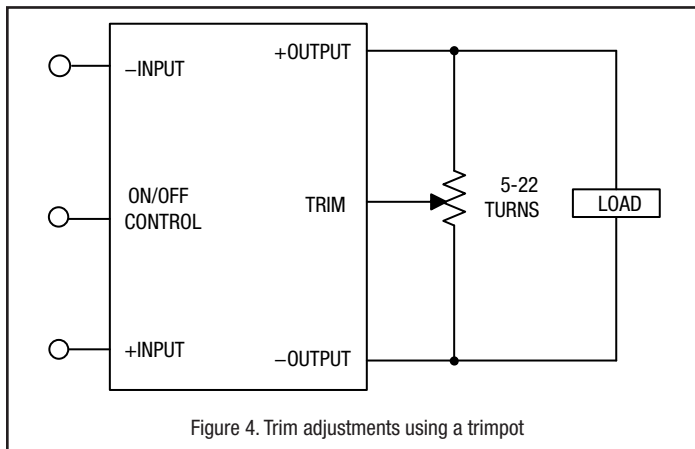

Figure 4. Trim adjustments using a trimpot

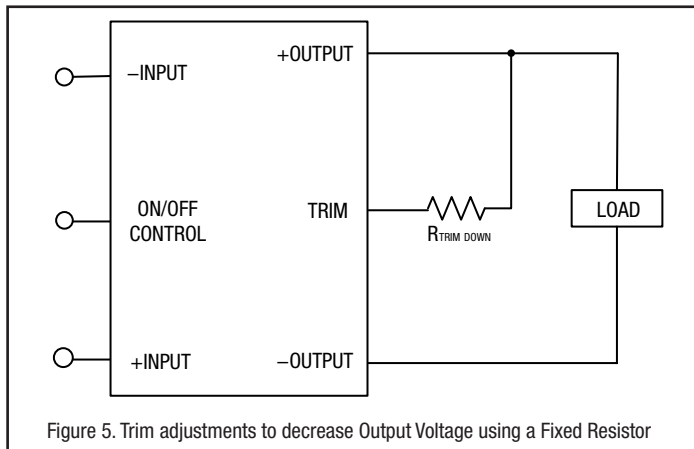

Figure 5. Trim adjustments to decrease Output Voltage using a Fixed Resistor

There are two CAUTIONs to be aware for the Trim input:

**CAUTION:** To avoid unplanned power down cycles, do not exceed EITHER the maximum output voltage OR the maximum output power when setting the trim. Be particularly careful with a trimpot. If the output voltage is excessive, the OVP circuit may inadvertently shut down the converter. If the maximum power is exceeded, the converter may enter current limiting. If the power is exceeded for an extended period, the converter may overheat and encounter overtemperature shut down.

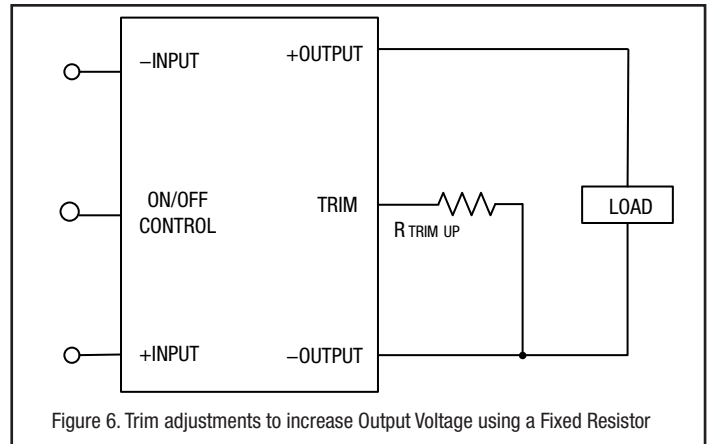

Figure 6. Trim adjustments to increase Output Voltage using a Fixed Resistor

**CAUTION:** Be careful of external electrical noise. The Trim input is a sensitive input to the converter’s feedback control loop. Excessive electrical noise may cause instability or oscillation. Keep external connections short to the Trim input. Use shielding if needed.

**Trim Equations**

**Trim Up**  
<Connect trim resistor between Trim and -Vout>

**Trim Down**  
<Connect trim resistor between Trim and +Vout>

UEI15-033-Q12, Q48	
$R_{TUP}(\Omega) = \frac{12775}{V_o - 3.3} - 2050$	$R_{TDOWN}(\Omega) = \frac{5110(V_o - 2.5)}{3.3 - V_o} - 2050$
UEI15-050-Q12, Q48	
$R_{TUP}(\Omega) = \frac{12775}{V_o - 5} - 2050$	$R_{TDOWN}(\Omega) = \frac{5110(V_o - 2.5)}{5 - V_o} - 2050$
UEI15-120-Q12, Q48	
$R_{TUP}(\Omega) = \frac{25000}{V_o - 12} - 5110$	$R_{TDOWN}(\Omega) = \frac{10000(V_o - 2.5)}{12 - V_o} - 5110$
UEI15-150-Q12, Q48	
$R_{TUP}(\Omega) = \frac{25000}{V_o - 15} - 5110$	$R_{TDOWN}(\Omega) = \frac{10000(V_o - 2.5)}{15 - V_o} - 5110$

Where  $V_o$  = Desired output voltage. Adjustment accuracy is subject to resistor tolerances and factory-adjusted output accuracy. Mount trim resistor close to converter. Use short leads.

**Remote On/Off Control**

On the input side, a remote On/Off Control can be ordered with either polarity.

Positive-polarity models are enabled when the On/Off pin is left open or is pulled high to +15V max. with respect to  $-V_{IN}$ . Some models will also turn on at lower intermediate voltages (see Specifications). Positive-polarity devices are



disabled when the On/Off is grounded or brought to within a low voltage (see Specifications) with respect to  $-V_{IN}$ .

Negative-polarity devices are on (enabled) when the On/Off is grounded or brought to within a low voltage (see Specifications) with respect to  $-V_{IN}$ . The device is off (disabled) when the On/Off is left open or is pulled high to  $+15V_{DC}$  max. with respect to  $-V_{IN}$ .

Dynamic control of the On/Off function should be able to sink appropriate signal current when brought low and withstand appropriate voltage when brought high. Be aware too that there is a finite time in milliseconds (see Specifications) between the time of On/Off Control activation and stable, regulated output. This time will vary slightly with output load type and current and input conditions.

There are three CAUTIONs for the On/Off Control:

**CAUTION:** To retain full output circuit isolation, control the On/Off from the input side ONLY. If you must control it from circuits in the output, use some form of optoisolation to the On/Off Control. This latter condition is unlikely because the device controlling the On/Off would have to remain powered on and not be powered from the converter.

**CAUTION:** While it is possible to control the On/Off with external logic if you carefully observe the voltage levels, the preferred circuit is either an open drain/open collector transistor, a switch or a relay (which can thereupon be controlled by logic).

**CAUTION:** Do not apply voltages to the On/Off pin when there is no input power voltage. Otherwise the converter may be permanently damaged.

**On/Off Enable Control Ground Bounce Protection**

To improve reliability, if you use a small signal transistor or other external circuit to select the Remote On/Off control, make sure to return the LO side directly to the  $-V_{IN}$  power input on the DC/DC converter. To avoid ground bounce errors, do not connect the On/Off return to a distant ground plane or current-carrying bus. If necessary, run a separate small return wire directly to the  $-V_{IN}$  terminal. There is very little current (typically 1-5 mA) on the On/Off control however, large current changes on a return ground plane or ground bus can accidentally trigger the converter on or off. If possible, mount the On/Off transistor or other control circuit adjacent to the converter.

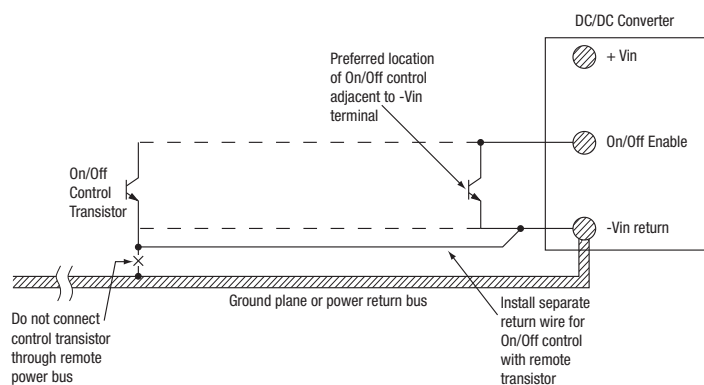

Figure 8. On/Off Enable Control Ground Bounce Protection

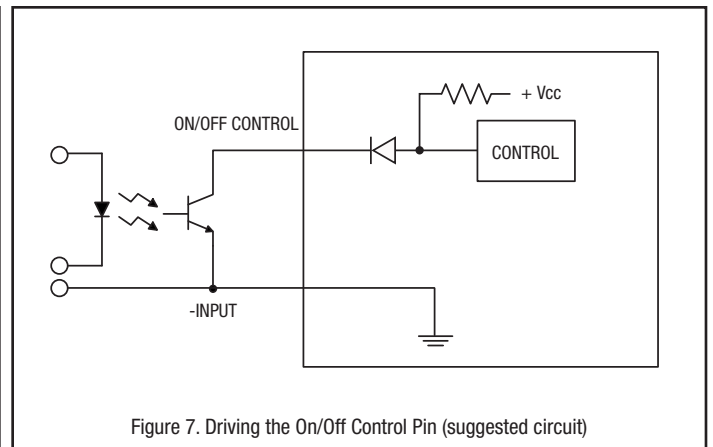

Figure 7. Driving the On/Off Control Pin (suggested circuit)

**Through-hole Soldering Guidelines**

Murata Power Solutions recommends the TH soldering specifications below when installing these converters. These specifications vary depending on the solder type. Exceeding these specifications may cause damage to the product. Your production environment may differ; therefore please thoroughly review these guidelines with your process engineers.

**Wave Solder Operations for through-hole mounted products (THMT)**

**For Sn/Ag/Cu based solders:**

Maximum Preheat Temperature	115° C.
Maximum Pot Temperature	270° C.
Maximum Solder Dwell Time	7 seconds

**For Sn/Pb based solders:**

Maximum Preheat Temperature	105° C.
Maximum Pot Temperature	250° C.
Maximum Solder Dwell Time	6 seconds

**SMT Reflow Soldering Guidelines**

The surface-mount reflow solder profile shown below is suitable for SAC305 type lead-free solders. This graph should be used only as a **guideline**. Many other factors influence the success of SMT reflow soldering. Since your production environment may differ, please thoroughly review these guidelines with your process engineers.

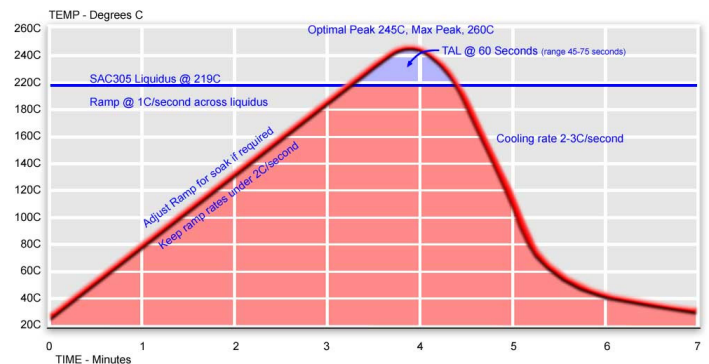

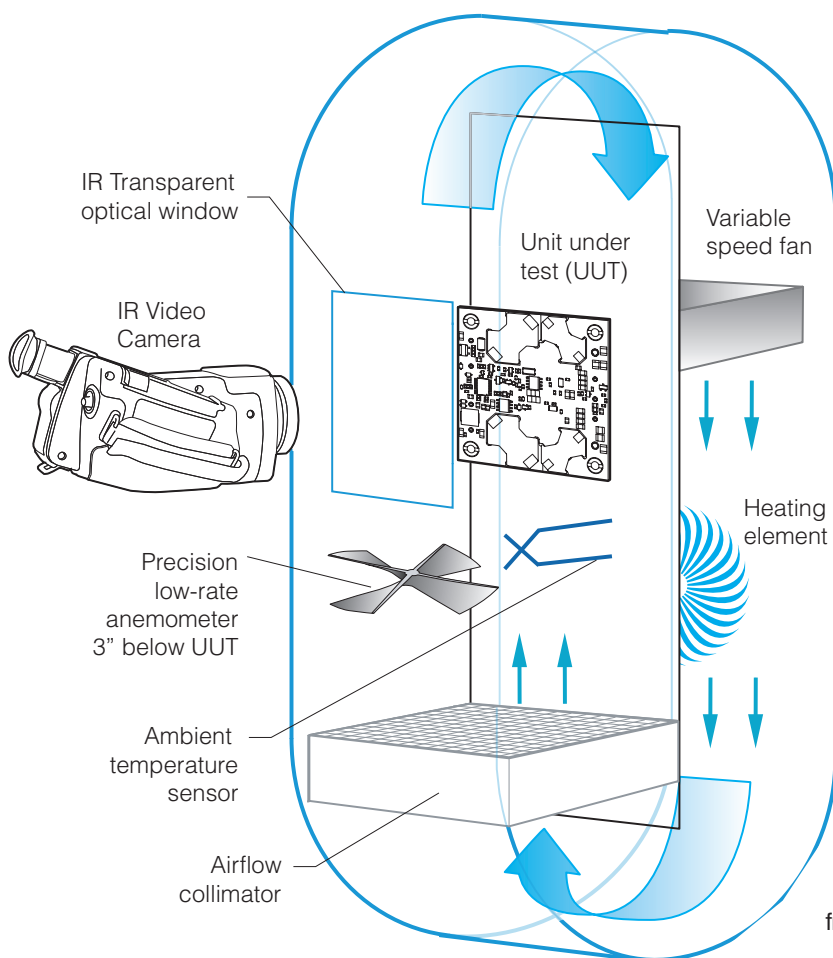

Figure 9. Vertical Wind Tunnel

**Vertical Wind Tunnel**

Murata Power Solutions employs a custom-designed enclosed vertical wind tunnel, infrared video camera system and test instrumentation for accurate airflow and heat dissipation analysis of power products. The system includes a precision low flow-rate anemometer, variable speed fan, power supply input and load controls, temperature gauges and adjustable heating element.

The IR camera can watch thermal characteristics of the Unit Under Test (UUT) with both dynamic loads and static steady-state conditions. A special optical port is used which is transparent to infrared wavelengths. The computer files from the IR camera can be studied for later analysis.

Both through-hole and surface mount converters are soldered down to a host carrier board for realistic heat absorption and spreading. Both longitudinal and transverse airflow studies are possible by rotation of this carrier board since there are often significant differences in the heat dissipation in the two airflow directions. The combination of both adjustable airflow, adjustable ambient heat and adjustable Input/Output currents and voltages mean that a very wide range of measurement conditions can be studied.

The airflow collimator mixes the heat from the heating element to make uniform temperature distribution. The collimator also reduces the amount of turbulence adjacent to the UUT by restoring laminar airflow. Such turbulence can change the effective heat transfer characteristics and give false readings. Excess turbulence removes more heat from some surfaces and less heat from others, possibly causing uneven overheating.

Both sides of the UUT are studied since there are different thermal gradients on each side. The adjustable heating element and fan, built-in temperature gauges and no-contact IR camera mean that power supplies are tested in real-world conditions.