

- 1N5518BUR-1 THRU 1N5546BUR-1 AVAILABLE IN JAN, JANTX AND JANTXV PER MIL-PRF-19500/437
- ZENER DIODE, 500mW
- LEADLESS PACKAGE FOR SURFACE MOUNT
- LOW REVERSE LEAKAGE CHARACTERISTICS
- METALLURGICALLY BONDED

1N5518BUR-1  
thru  
1N5546BUR-1  
and  
CDLL5518 thru CDLL5546D

## MAXIMUM RATINGS

Junction and Storage Temperature: -65°C to +125°C  
DC Power Dissipation: 500 mW @  $T_{EC} = +125^{\circ}C$   
Power Derating: 10 mW / °C above  $T_{EC} = +125^{\circ}C$   
Forward Voltage @ 200mA: 1.1 volts maximum

ELECTRICAL CHARACTERISTICS @ 25°C, unless otherwise specified.

CDI TYPE NUMBER (NOTE 1)	NOMINAL ZENER VOLTAGE $V_Z @ 1Z_T$ (NOTE 2)	ZENER TEST CURRENT 1Z_T	MAX. ZENER IMPEDANCE B-C-D SUFFIX $Z_{ZT} @ 1Z_T$ (NOTE 3)	MAXIMUM REVERSE LEAKAGE CURRENT			B-C-D SUFFIX MAXIMUM DC ZENER $1Z_M$	REGULATION FACTOR CURRENT $\Delta V_Z$ (NOTE 5)	LOW $V_Z$ CURRENT 1Z_L
				$I_R$ (NOTE 4)		$V_R = \text{VOLTS}$			
				$\mu A_{dc}$	NON & A-SUFFIX				
	VOLTS	mA	OHMS	$\mu A_{dc}$			mA	VOLTS	mA
CDLL5518B	3.3	20	26	5.0	0.90	1.0	115	0.90	2.0
CDLL5519B	3.6	20	24	3.0	0.90	1.0	105	0.90	2.0
CDLL5520B	3.9	20	22	1.0	0.90	1.0	98	0.85	2.0
CDLL5521B	4.3	20	18	3.0	1.0	1.5	88	0.75	2.0
CDLL5522B	4.7	10	22	2.0	1.5	2.0	81	0.60	1.0
CDLL5523B	5.1	5.0	26	2.0	2.0	2.5	75	0.65	0.25
CDLL5524B	5.6	3.0	30	2.0	3.0	3.5	68	0.30	0.25
CDLL5525B	6.2	1.0	30	1.0	4.5	5.0	61	0.20	0.01
CDLL5526B	6.8	1.0	30	1.0	5.5	6.2	56	0.10	0.01
CDLL5527B	7.5	1.0	35	0.5	6.0	6.8	51	0.05	0.01
CDLL5528B	8.2	1.0	40	0.5	6.5	7.5	46	0.05	0.01
CDLL5529B	9.1	1.0	45	0.1	7.0	8.2	42	0.05	0.01
CDLL5530B	10.0	1.0	60	0.05	8.0	9.1	38	0.10	0.01
CDLL5531B	11.0	1.0	80	0.05	9.0	9.9	35	0.20	0.01
CDLL5532B	12.0	1.0	90	0.05	9.5	10.8	32	0.20	0.01
CDLL5533B	13.0	1.0	90	0.01	10.5	11.7	29	0.20	0.01
CDLL5534B	14.0	1.0	100	0.01	11.5	12.6	27	0.20	0.01
CDLL5535B	15.0	1.0	100	0.01	12.5	13.5	25	0.20	0.01
CDLL5536B	16.0	1.0	100	0.01	13.0	14.4	24	0.20	0.01
CDLL5537B	17.0	1.0	100	0.01	14.0	15.3	22	0.20	0.01
CDLL5538B	18.0	1.0	100	0.01	15.0	16.2	21	0.20	0.01
CDLL5539B	19.0	1.0	100	0.01	16.0	17.1	20	0.20	0.01
CDLL5540B	20.0	1.0	100	0.01	17.0	18.0	19	0.20	0.01
CDLL5541B	22.0	1.0	100	0.01	18.0	19.8	17	0.25	0.01
CDLL5542B	24.0	1.0	100	0.01	20.0	21.6	16	0.30	0.01
CDLL5543B	25.0	1.0	100	0.01	21.0	22.4	15	0.35	0.01
CDLL5544B	28.0	1.0	100	0.01	23.0	25.2	14	0.40	0.01
CDLL5545B	30.0	1.0	100	0.01	24.0	27.0	13	0.45	0.01
CDLL5546B	33.0	1.0	100	0.01	28.0	29.7	12	0.50	0.01

- NOTE 1** No Suffix type numbers are  $\pm 20\%$  with guaranteed limits for only  $V_Z$ ,  $I_R$ , and  $V_F$ . Units with "A" suffix are  $\pm 10\%$  with guaranteed limits for  $V_Z$ ,  $I_R$ , and  $V_F$ . Units with guaranteed limits for all six parameters are indicated by a "B" suffix for  $\pm 5.0\%$  units, "C" suffix for  $\pm 2.0\%$  and "D" suffix for  $\pm 1.0\%$ .
- NOTE 2** Zener voltage is measured with the device junction in thermal equilibrium at an ambient temperature of  $25^{\circ}C \pm 3^{\circ}C$ .
- NOTE 3** Zener impedance is derived by superimposing on  $1Z_T$  A 60Hz rms a.c. current equal to 10% of  $1Z_T$ .
- NOTE 4** Reverse leakage currents are measured at  $V_R$  as shown on the table.
- NOTE 5**  $\Delta V_Z$  is the maximum difference between  $V_Z$  at  $1Z_T$  and  $V_Z$  at  $1Z_L$  measured with the device junction in thermal equilibrium.

1N5518BUR-1  
thru  
1N5546BUR-1  
and

CDLL5518 thru CDLL5546D

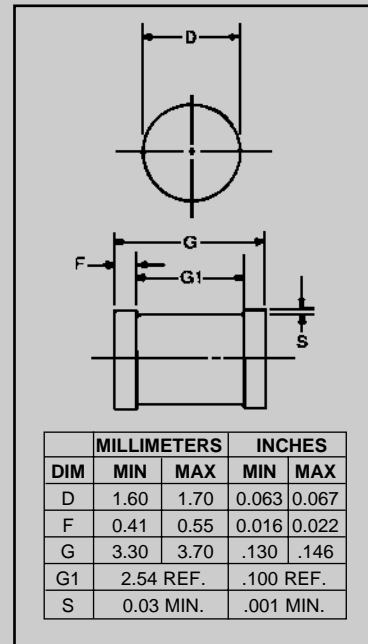

FIGURE 1

## DESIGN DATA

**CASE:** DO-213AA, Hermetically sealed glass case. (MELF, SOD-80, LL34)

**LEAD FINISH:** Tin / Lead

**THERMAL RESISTANCE:** ( $R_{\theta JEC}$ ): 100 °C/W maximum at L = 0 inch

**THERMAL IMPEDANCE:** ( $Z_{\theta JX}$ ): 35 °C/W maximum

**POLARITY:** Diode to be operated with the banded (cathode) end positive.

**MOUNTING SURFACE SELECTION:** The Axial Coefficient of Expansion (COE) Of this Device is Approximately +6PPM/°C. The COE of the Mounting Surface System Should Be Selected To Provide A Suitable Match With This Device.



6 LAKE STREET, LAWRENCE, MASSACHUSETTS 01841  
PHONE (978) 620-2600  
WEBSITE: <http://www.microsemi.com>

FAX (978) 689-0803

# CDLL5518 thru CDLL5546D

FIGURE 2

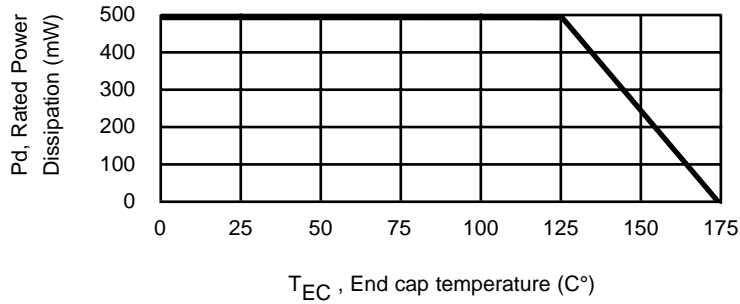

POWER DERATING CURVE

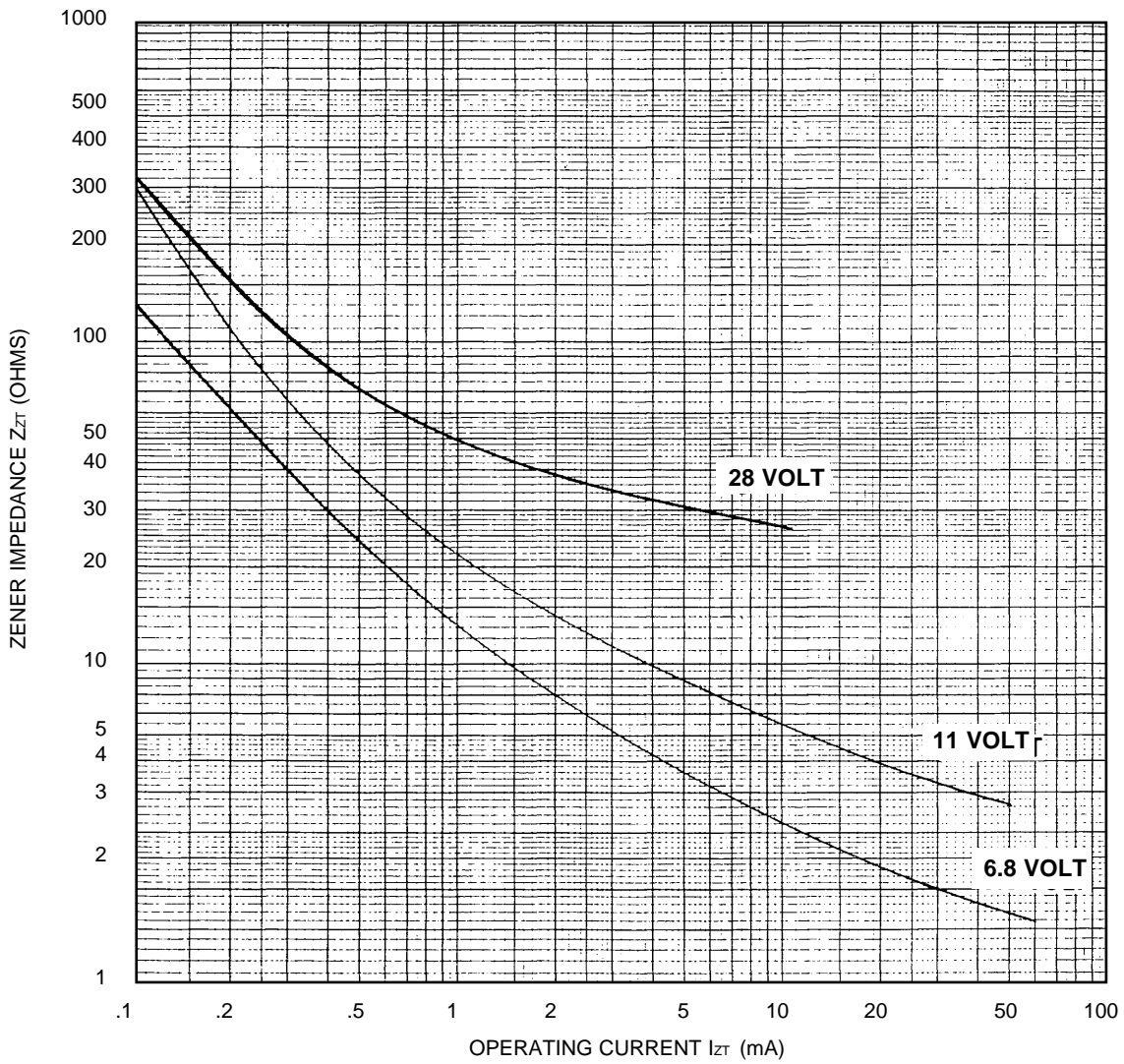

FIGURE 3

ZENER IMPEDANCE VS. OPERATING CURRENT