

Zener Diodes with Surge Current Specification

Features

- Silicon planar Zener diodes
- Low profile surface-mount package
- Zener and surge current specification
- Low leakage current
- Excellent stability
- High temperature soldering: 260 °C/10 s at terminals
- AEC-Q101 qualified
- Compliant to RoHS directive 2002/95/EC and in accordance to WEEE 2002/96/EC
- Halogen-free according to IEC 61249-2-21 definition

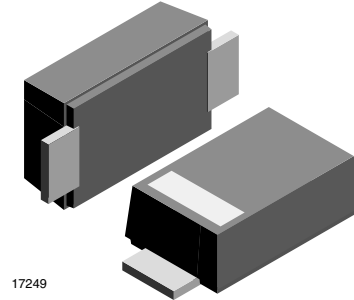

17249

Mechanical Data

Case: DO-219AB (SMF)

Weight: approx. 15 mg

Packaging codes/options:

18/10 k per 13 " reel (8 mm tape), 10 k/box

08/3 k per 7 " reel (8 mm tape), 15 k/box

Absolute Maximum Ratings

$T_{amb} = 25\text{ °C}$, unless otherwise specified

Parameter	Test condition	Symbol	Value	Unit
Power dissipation	$T_L = 80\text{ °C}$	P_{tot}	2.3	W
	$T_A = 25\text{ °C}$	P_{tot}	0.8 ¹⁾	W
Non-repetitive peak pulse power dissipation	100 μ s square pulse ²⁾	P_{ZSM}	300	W
	10/1000 μ s waveform (BZD27-C7V5P-M to BZD27-C100P-M) ²⁾	P_{RSM}	150	W
	10/1000 μ s waveform (BZD27-C110P-M to BZD27-C200P-M) ²⁾	P_{RSM}	100	W

Note:

¹⁾ Mounted on epoxy-glass PCB with 3 mm x 3 mm Cu pads ($\geq 40\text{ }\mu\text{m}$ thick)

²⁾ $T_J = 25\text{ °C}$ prior to surge

Thermal Characteristics

$T_{amb} = 25\text{ °C}$, unless otherwise specified

Parameter	Test condition	Symbol	Value	Unit
Thermal resistance junction to ambient air ¹⁾		R_{thJA}	180	K/W
Thermal resistance junction to lead		R_{thJL}	30	K/W
Maximum junction temperature		T_J	150	°C
Storage temperature range		T_S	- 55 to + 150	°C

Note:

¹⁾ Mounted on epoxy-glass PCB with 3 mm x 3 mm Cu pads ($\geq 40\text{ }\mu\text{m}$ thick)

BZD27C3V6P-M to BZD27C200P-M



Vishay Semiconductors

Electrical Characteristics

Maximum $V_F = 1.2$ V, at $I_F = 0.2$ A

When used as voltage regulator diodes ($T_J = 25$ °C, unless otherwise specified)

Part number	Marking code	Working voltage ¹⁾		Differential resistance		Temperature coefficient		Test current	Reverse current at reverse voltage	
		V_Z at I_{ZT}		r_{dif} at I_Z		α_Z at I_Z		I_{ZT}	I_R	V_R
		V		Ω		%/°C		mA	μ A	V
		min.	max.	typ.	max.	min.	max.		max.	
BZD27C3V6P-M	N0	3.4	3.8	4	8	- 0.14	- 0.04	100	100	1
BZD27C3V9P-M	N1	3.7	4.1	4	8	- 0.14	- 0.04	100	50	1
BZD27C4V3P-M	N2	4	4.6	4	7	- 0.12	- 0.02	100	25	1
BZD27C4V7P-M	N3	4.4	5	3	7	- 0.1	0	100	10	1
BZD27C5V1P-M	N4	4.8	5.4	3	6	- 0.08	0.02	100	5	1
BZD27C5V6P-M	N5	5.2	6	2	4	- 0.04	0.04	100	10	2
BZD27C6V2P-M	N6	5.8	6.6	2	3	- 0.01	0.06	100	5	2
BZD27C6V8P-M	N7	6.4	7.2	1	3	0	0.07	100	10	3
BZD27C7V5P-M	N8	7	7.9	1	2	0	0.07	100	50	3
BZD27C8V2P-M	N9	7.7	8.7	1	2	0.03	0.08	100	10	3
BZD27C9V1P-M	O0	8.5	9.6	2	4	0.03	0.08	50	10	5
BZD27C10P-M	O1	9.4	10.6	2	4	0.05	0.09	50	7	7.5
BZD27C11P-M	O2	10.4	11.6	4	7	0.05	0.1	50	4	8.2
BZD27C12P-M	O3	11.4	12.7	4	7	0.05	0.1	50	3	9.1
BZD27C13P-M	O4	12.4	14.1	5	10	0.05	0.1	50	2	10
BZD27C15P-M	O5	13.8	15.6	5	10	0.05	0.1	50	1	11
BZD27C16P-M	O6	15.3	17.1	6	15	0.06	0.11	25	1	12
BZD27C18P-M	O7	16.8	19.1	6	15	0.06	0.11	25	1	13
BZD27C20P-M	O8	18.8	21.2	6	15	0.06	0.11	25	1	15
BZD27C22P-M	O9	20.8	23.3	6	15	0.06	0.11	25	1	16
BZD27C24P-M	P0	22.8	25.6	7	15	0.06	0.11	25	1	18
BZD27C27P-M	P1	25.1	28.9	7	15	0.06	0.11	25	1	20
BZD27C30P-M	P2	28	32	8	15	0.06	0.11	25	1	22
BZD27C33P-M	P3	31	35	8	15	0.06	0.11	25	1	24
BZD27C36P-M	P4	34	38	21	40	0.06	0.11	10	1	27
BZD27C39P-M	P5	37	41	21	40	0.06	0.11	10	1	30
BZD27C43P-M	P6	40	46	24	45	0.07	0.12	10	1	33
BZD27C47P-M	P7	44	50	24	45	0.07	0.12	10	1	36
BZD27C51P-M	P8	48	54	25	60	0.07	0.12	10	1	39
BZD27C56P-M	P9	52	60	25	60	0.07	0.12	10	1	43
BZD27C62P-M	Q0	58	66	25	80	0.08	0.13	10	1	47
BZD27C68P-M	Q1	64	72	25	80	0.08	0.13	10	1	51
BZD27C75P-M	Q2	70	79	30	100	0.08	0.13	10	1	56
BZD27C82P-M	Q3	77	87	30	100	0.08	0.13	10	1	62
BZD27C91P-M	Q4	85	96	60	200	0.08	0.13	5	1	68
BZD27C100P-M	Q5	94	106	60	200	0.09	0.13	5	1	75
BZD27C110P-M	Q6	104	116	80	250	0.09	0.13	5	1	82
BZD27C120P-M	Q7	114	127	80	250	0.09	0.13	5	1	91
BZD27C130P-M	Q8	124	141	110	300	0.09	0.13	5	1	100
BZD27C150P-M	Q9	138	156	130	300	0.09	0.13	5	1	110
BZD27C160P-M	R0	153	171	150	350	0.09	0.13	5	1	120
BZD27C180P-M	R1	168	191	180	400	0.09	0.13	5	1	130
BZD27C200P-M	R2	188	212	200	500	0.09	0.13	5	1	150

Note:

¹⁾ Pulse test: $t_p \leq 5$ ms.



BZD27C3V6P-M to BZD27C200P-M

Vishay Semiconductors

Electrical Characteristics

When used as protection diodes ($T_J = 25\text{ }^\circ\text{C}$, unless otherwise specified)

Part number	Rev. breakdown voltage	Test current	Temperature coefficient		Clamping voltage		Reverse current at stand-off voltage	
	$V_{(BR)R}$ at I_{test}	I_{test}	α_Z at I_{test}		V_C	at $I_{RSM}^{1)}$	I_R	at V_{WM}
	V	mA	%/ $^\circ\text{C}$		V	A	μA	V
	min.		min.	max.	max .		max.	
BZD27C7V5P-M	7	100	0	0.07	11.3	13.3	1500	6.2
BZD27C8V2P-M	7.7	100	0.03	0.08	12.3	12.2	1200	6.8
BZD27C9V1P-M	8.5	50	0.03	0.08	13.3	11.3	100	7.5
BZD27C10P-M	9.4	50	0.05	0.09	14.8	10.1	20	8.2
BZD27C11P-M	10.4	50	0.05	0.1	15.7	9.6	5	9.1
BZD27C12P-M	11.4	50	0.05	0.1	17	8.8	5	10
BZD27C13P-M	12.4	50	0.05	0.1	18.9	7.9	5	11
BZD27C15P-M	13.8	50	0.05	0.1	20.9	7.2	5	12
BZD27C16P-M	15.3	25	0.06	0.11	22.9	6.6	5	13
BZD27C18P-M	16.8	25	0.06	0.11	25.6	5.9	5	15
BZD27C20P-M	18.8	25	0.06	0.11	28.4	5.3	5	16
BZD27C22P-M	20.8	25	0.06	0.11	31	4.8	5	18
BZD27C24P-M	22.8	25	0.06	0.11	33.8	4.4	5	20
BZD27C27P-M	25.1	25	0.06	0.11	38.1	3.9	5	22
BZD27C30P-M	28	25	0.06	0.11	42.2	3.6	5	24
BZD27C33P-M	31	25	0.06	0.11	46.2	3.2	5	27
BZD27C36P-M	34	10	0.06	0.11	50.1	3	5	30
BZD27C39P-M	37	10	0.06	0.11	54.1	2.8	5	33
BZD27C43P-M	40	10	0.07	0.12	60.7	2.5	5	36
BZD27C47P-M	44	10	0.07	0.12	65.5	2.3	5	39
BZD27C51P-M	48	10	0.07	0.12	70.8	2.1	5	43
BZD27C56P-M	52	10	0.07	0.12	78.6	1.9	5	47
BZD27C62P-M	58	10	0.08	0.13	86.5	1.7	5	51
BZD27C68P-M	64	10	0.08	0.13	94.4	1.6	5	56
BZD27C75P-M	70	10	0.08	0.13	103.5	1.5	5	62
BZD27C82P-M	77	10	0.08	0.13	114	1.3	5	68
BZD27C91P-M	85	5	0.09	0.13	126	1.2	5	75
BZD27C100P-M	94	5	0.09	0.13	139	1.1	5	82
BZD27C110P-M	104	5	0.09	0.13	139	0.72	5	91
BZD27C120P-M	114	5	0.09	0.13	152	0.65	5	100
BZD27C130P-M	124	5	0.09	0.13	169	0.59	5	110
BZD27C150P-M	138	5	0.09	0.13	187	0.53	5	120
BZD27C160P-M	153	5	0.09	0.13	205	0.48	5	130
BZD27C180P-M	168	5	0.09	0.13	229	0.43	5	150
BZD27C200P-M	188	5	0.09	0.13	254	0.39	5	160

Note:

¹⁾ Non-repetitive peak reverse current in accordance with "IEC 60-1, section 8" (10/1000 μs pulse); see fig. 5.

BZD27C3V6P-M to BZD27C200P-M



Vishay Semiconductors

Typical Characteristics

$T_{amb} = 25\text{ }^{\circ}\text{C}$, unless otherwise specified

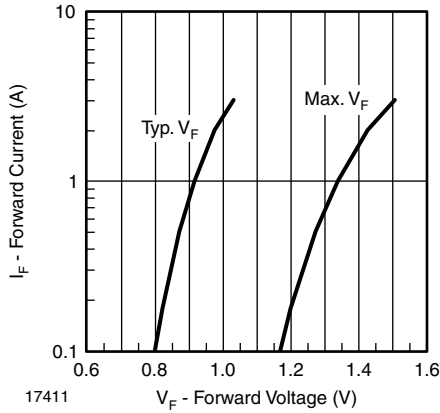

Figure 1. Forward Current vs. Forward Voltage

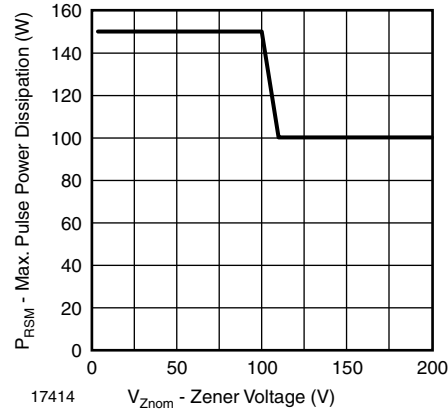

Figure 4. Maximum Pulse Power Dissipation vs. Zener Voltage

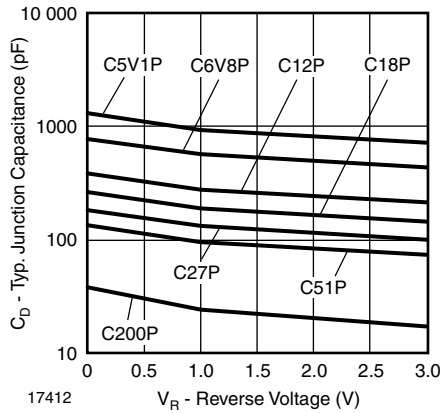

Figure 2. Typ. Diode Capacitance vs. Reverse Voltage

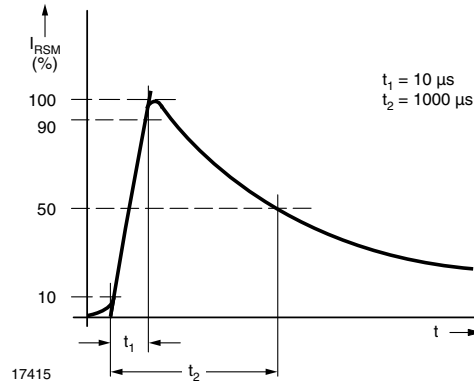

Figure 5. Non-Repetitive Peak Reverse Current Pulse Definition

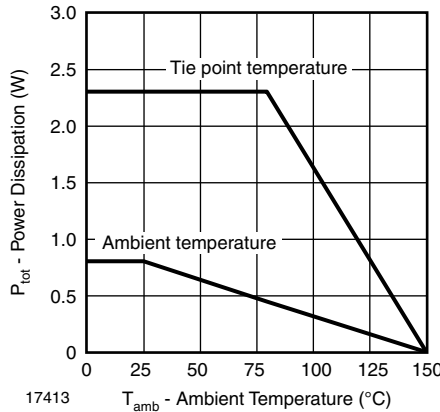
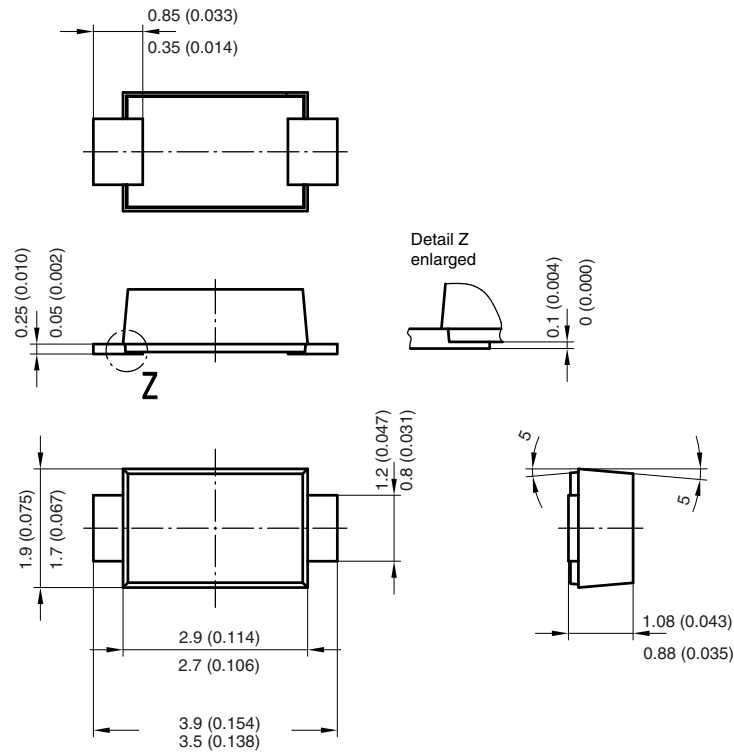
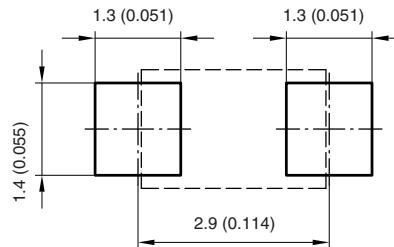

Figure 3. Power Dissipation vs. Ambient Temperature

Package Dimensions in millimeters (inches): DO219-AB (SMF)



Foot print recommendation:



Created - Date: 15. February 2005
Rev. 3 - Date: 13. March 2007
Document no.:S8-V-3915.01-001 (4)
17247

BZD27C3V6P-M to BZD27C200P-M



Vishay Semiconductors

Blister Tape Dimensions for SMF in millimeters

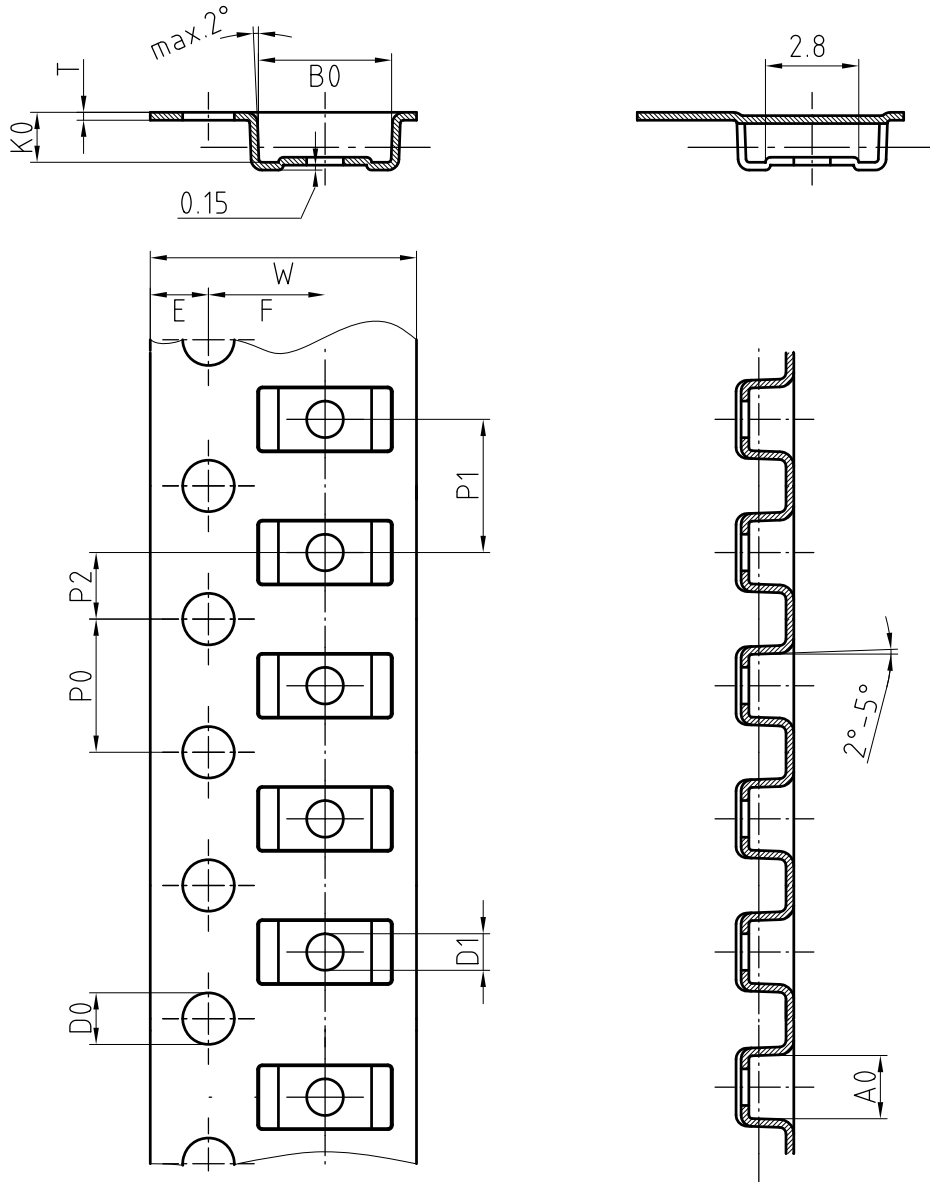

Mat:	A0	B0	K0	W	T	P0	P2	P1	D0	D1	E	F
PS	1.9	4.0	1.5	8.0	0.235	4.0	2.0	4.0	1.5	1	1.75	3.5

Document-No.: S8-V-3717.02-001 (3)

18513



Disclaimer

ALL PRODUCT, PRODUCT SPECIFICATIONS AND DATA ARE SUBJECT TO CHANGE WITHOUT NOTICE TO IMPROVE RELIABILITY, FUNCTION OR DESIGN OR OTHERWISE.

Vishay Intertechnology, Inc., its affiliates, agents, and employees, and all persons acting on its or their behalf (collectively, "Vishay"), disclaim any and all liability for any errors, inaccuracies or incompleteness contained in any datasheet or in any other disclosure relating to any product.

Vishay makes no warranty, representation or guarantee regarding the suitability of the products for any particular purpose or the continuing production of any product. To the maximum extent permitted by applicable law, Vishay disclaims (i) any and all liability arising out of the application or use of any product, (ii) any and all liability, including without limitation special, consequential or incidental damages, and (iii) any and all implied warranties, including warranties of fitness for particular purpose, non-infringement and merchantability.

Statements regarding the suitability of products for certain types of applications are based on Vishay's knowledge of typical requirements that are often placed on Vishay products in generic applications. Such statements are not binding statements about the suitability of products for a particular application. It is the customer's responsibility to validate that a particular product with the properties described in the product specification is suitable for use in a particular application. Parameters provided in datasheets and/or specifications may vary in different applications and performance may vary over time. All operating parameters, including typical parameters, must be validated for each customer application by the customer's technical experts. Product specifications do not expand or otherwise modify Vishay's terms and conditions of purchase, including but not limited to the warranty expressed therein.

Except as expressly indicated in writing, Vishay products are not designed for use in medical, life-saving, or life-sustaining applications or for any other application in which the failure of the Vishay product could result in personal injury or death. Customers using or selling Vishay products not expressly indicated for use in such applications do so at their own risk and agree to fully indemnify and hold Vishay and its distributors harmless from and against any and all claims, liabilities, expenses and damages arising or resulting in connection with such use or sale, including attorneys fees, even if such claim alleges that Vishay or its distributor was negligent regarding the design or manufacture of the part. Please contact authorized Vishay personnel to obtain written terms and conditions regarding products designed for such applications.

No license, express or implied, by estoppel or otherwise, to any intellectual property rights is granted by this document or by any conduct of Vishay. Product names and markings noted herein may be trademarks of their respective owners.