

Solderless terminals

RING TONGUE (R type) Vinyl-insulated with copper sleeve

The terminal barrel is first covered with a copper sleeve and then insulated with vinyl; it is extremely resistant to vibration.

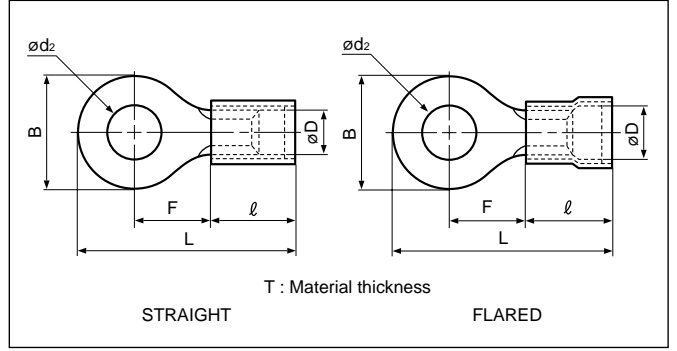
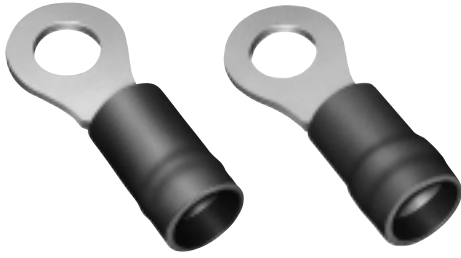

File No.: E42024 LR20812

Applicable Wire AWG#(mm ²)	Stud size		Part No.		Standard	Dimensions mm (in.)										Color	Tool No.	Qty/box
	American	Metric	Straight	Flared		ϕd_2	B	L	F	ℓ	ϕD		T					
26 to 22 (0.2 to 0.5)	1-2	2	VD0.5-2	-		2.2 (.087)	5.2 (.205)	16.4 (.646)	5.8 (.228)	8.0 (.315)	2.2 (.087)	2.5 (.098)	0.5 (.020)	Yellow	YNT-2622 YA-1 YA-2 BCT-0514	1,000		
	3-4	3	VD0.5-3	-		3.2 (.126)	5.2 (.205)	16.4 (.646)	5.8 (.228)									
	8	4	VD0.5-4	-		4.3 (.169)	6.6 (.260)	19.0 (.748)	7.7 (.303)									
	10	5	VD0.5-5	-		5.3 (.209)	8.0 (.315)	19.0 (.748)	7.0 (.276)									
	1-2	2	-	FVD0.5-2		2.2 (.087)	5.2 (.205)	16.7 (.657)	5.8 (.228)									
	3-4	3	-	FVD0.5-3		3.2 (.126)	5.2 (.205)	16.7 (.657)	5.8 (.228)									
	8	4	-	FVD0.5-4		4.3 (.169)	6.6 (.260)	19.3 (.760)	7.7 (.303)									
22 to 16 (0.25 to 1.65)	1-2	2	VD1.25-2	FVD1.25-2		2.2 (.087)	5.5 (.217)	16.3 (.642)	4.0 (.157)	9.6 (.378)	3.5 (.138)	4.0 (.157)	0.8 (.031)	Red	YNT-2216 YA-1 YA-2 YA-4 BCT-0514	1,000		
	3-4	3	VD1.25-3	FVD1.25-3		3.2 (.126)	5.5 (.217)	16.3 (.642)	4.0 (.157)									
	3-4	3	VD1.25-MS3	FVD1.25-MS3		3.2 (.126)	5.5 (.217)	18.0 (.709)	5.6 (.220)									
	3-4	3	VD1.25-L3	FVD1.25-L3		3.2 (.126)	8.0 (.315)	20.6 (.811)	7.0 (.276)									
	5-6	3.5	VD1.25-3.7	FVD1.25-3.7		3.7 (.146)	5.5 (.217)	16.3 (.642)	4.0 (.157)									
	5-6	3.5	VD1.25-M3	FVD1.25-M3		3.7 (.146)	6.6 (.260)	19.2 (.756)	6.3 (.248)									
	8	4	VD1.25-M4	FVD1.25-M4		4.3 (.169)	6.6 (.260)	19.2 (.756)	6.3 (.248)									
	8	4	VD1.25-4	FVD1.25-4		4.3 (.169)	8.0 (.315)	20.6 (.811)	7.0 (.276)									
	10	5	VD1.25-5	FVD1.25-5		5.3 (.209)	8.0 (.315)	20.6 (.811)	7.0 (.276)									
	1/4	6	VD1.25-6	FVD1.25-6		6.4 (.252)	11.6 (.457)	26.5 (1.043)	11.1 (.437)									
	5/16	8	VD1.25-8	FVD1.25-8		8.4 (.331)	11.6 (.457)	26.5 (1.043)	11.1 (.437)									
	3/8	10	VD1.25-10	FVD1.25-10		10.5 (.413)	13.6 (.535)	30.3 (1.193)	13.9 (.547)									
	16 to 14 (1.04 to 2.63)	1-2	2	VD2-S2		FVD2-S2		2.2 (.087)	6.4 (.252)								17.1 (.673)	4.3 (.169)
3-4		3	VD2-MS3	FVD2-MS3	3.2 (.126)	5.5 (.217)		18.0 (.709)	5.6 (.220)									
3-4		3	VD2-S3.3	FVD2-S3.3	3.2 (.126)	6.4 (.252)		17.1 (.673)	4.3 (.169)									
3-4		3	VD2-3	FVD2-3	3.2 (.126)	8.5 (.335)		21.6 (.850)	7.8 (.307)									
5-6		3.5	VD2-S3	FVD2-S3	3.7 (.146)	6.4 (.252)		17.1 (.673)	4.3 (.169)									
5-6		3.5	VD2-M3	FVD2-M3	3.7 (.146)	6.6 (.260)		19.2 (.756)	6.3 (.248)									
5-6		3.5	VD2-P3.5	FVD2-P3.5	3.7 (.146)	7.0 (.276)		20.8 (.819)	7.7 (.303)									
8		4	VD2-M4	FVD2-M4	4.3 (.169)	6.6 (.260)		19.2 (.756)	6.3 (.248)									
8		4	VD2-P4	FVD2-P4	4.3 (.169)	7.0 (.276)		20.8 (.819)	7.7 (.303)									
8		4	VD2-4	FVD2-4	4.3 (.169)	8.5 (.335)		21.6 (.850)	7.8 (.307)									
10		5	VD2-M5	FVD2-M5	5.3 (.209)	8.5 (.335)		21.6 (.850)	7.8 (.307)									
10		5	VD2-5	FVD2-5	5.3 (.209)	9.5 (.374)		21.6 (.850)	7.3 (.287)									
1/4		6	VD2-6	FVD2-6	6.4 (.252)	12.0 (.472)		26.6 (1.047)	11.0 (.433)									
5/16		8	VD2-8	FVD2-8	8.4 (.331)	12.0 (.472)		26.6 (1.047)	11.0 (.433)									
3/8		10	VD2-10	FVD2-10	10.5 (.413)	13.6 (.535)		30.3 (1.193)	13.9 (.547)									
1/2		12	VD2-12	FVD2-12	13.0 (.512)	19.0 (.748)		35.8 (1.409)	16.7 (.657)									
1/2		14	VD2-14	FVD2-14	15.0 (.591)	27.0 (1.063)		44.3 (1.744)	21.2 (.835)									
5/8	16	VD2-16	FVD2-16	17.0 (.669)	27.0 (1.063)	44.3 (1.744)	21.2 (.835)											
3/4	20	VD2-20	FVD2-20	21.0 (.827)	27.0 (1.063)	44.3 (1.744)	21.2 (.835)											
12 to 10 (2.63 to 6.64)	3-4	3	VD5.5-3	FVD5.5-3		3.2 (.126)	9.5 (.374)	27.0 (1.063)	8.3 (.327)	14.0 (.551)	5.7 (.224)	6.5 (.256)	1.0 (.039)	Yellow	YNT-1210S YA-4 BCT-0514	500		
	5-6	3.5	VD5.5-S3	FVD5.5-S3		3.7 (.146)	7.2 (.283)	23.5 (.925)	5.9 (.232)									
	8	4	VD5.5-S4	FVD5.5-S4		4.3 (.169)	7.2 (.283)	23.5 (.925)	5.9 (.232)									
	8	4	VD5.5-4	FVD5.5-4		4.3 (.169)	9.5 (.374)	27.0 (1.063)	8.3 (.327)									
	10	5	VD5.5-5	FVD5.5-5		5.3 (.209)	9.5 (.374)	27.0 (1.063)	8.3 (.327)									
	10	5	VD5.5-S5	FVD5.5-S5		5.3 (.209)	13.2 (.520)	29.6 (1.165)	9.0 (.354)									
	1/4	6	VD5.5-6	FVD5.5-6		6.4 (.252)	12.0 (.472)	33.0 (1.299)	13.0 (.512)									
	1/4	6	VD5.5-S6	FVD5.5-S6		6.4 (.252)	13.2 (.520)	29.6 (1.165)	9.0 (.354)									
	5/16	8	VD5.5-S8	FVD5.5-S8		8.4 (.331)	13.2 (.520)	29.6 (1.165)	9.0 (.354)									
	5/16	8	VD5.5-8	FVD5.5-8		8.4 (.331)	15.0 (.591)	35.2 (1.386)	13.7 (.539)									
	3/8	10	VD5.5-10	FVD5.5-10		10.5 (.413)	15.0 (.591)	35.2 (1.386)	13.7 (.539)									
	1/2	12	VD5.5-12	FVD5.5-12		13.0 (.512)	19.2 (.756)	39.6 (1.559)	16.0 (.630)									
	1/2	14	VD5.5-14	FVD5.5-14		15.0 (.591)	32.0 (1.260)	55.3 (2.177)	25.3 (.996)									
	5/8	16	VD5.5-16	FVD5.5-16		17.0 (.669)	32.0 (1.260)	55.3 (2.177)	25.3 (.996)									
	11/16	18	VD5.5-18	FVD5.5-18		19.0 (.748)	32.0 (1.260)	55.3 (2.177)	25.3 (.996)									
	3/4	20	VD5.5-20	FVD5.5-20		21.0 (.827)	32.0 (1.260)	55.3 (2.177)	25.3 (.996)									

Note: 1) The part numbers indicated in the above table are for products with a brazed seam.
 When ordering products with a butted seam, add the prefix "WS" to the part number (ex. VD2-4 →VDWS2-4).
 2) To order products with nylon insulation, change the "V" in the part number prefix to "N" (ex. FVD2-4 →FND2-4).
 Because nylon absorbs moisture, care must be taken concerning storage.
 3) Delivery lead times may vary depending on the product. Contact JST for details.

Solderless terminals



RING TONGUE (R type) Vinyl-insulated with copper sleeve (Medium size)

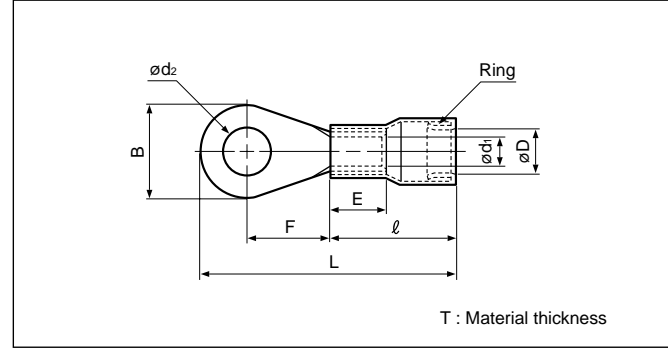

File No.: E42024 LR20812

Applicable Wire AWG#(mm ²)	Stud size		Part No.	Standard	Dimensions mm (in.)										Color	Tool No.	Qty/box
	American	Metric			ϕd_2	B	L	F	E	ℓ	d_1	ϕD (min.)	T				
8 (6.64 to 10.52)	10	5	FVD8-5		5.3 (.209)	10.3 (.406)	36.3(1.429)	10.6 (.417)	8.3 (.327)	19.2 (.756)	4.6 (.181)	7.5 (.295)	1.1 (.043)	Red	YF-1 YNE-38 E-4	200	
	1/4	6	FVD8-6		6.4 (.252)	11.6 (.457)	36.3(1.429)	11.3 (.445)									
	5/16	8	FVD8-8		8.4 (.331)	14.4 (.567)	38.8(1.528)	12.4 (.488)									
	3/8	10	FVD8-10		10.5 (.413)	14.4 (.567)	38.8(1.528)	12.4 (.488)									
6 (10.52 to 16.78)	10	5	FVD14-5		5.3 (.209)	12.2 (.480)	39.2(1.543)	13.1 (.516)	10.9 (.429)	20.0 (.787)	5.7 (.224)	10.5 (.413)	1.1 (.043)	Blue	YF-1 YNE-38 E-4	100	
	1/4	6	FVD14-6		6.4 (.252)	12.2 (.480)	39.2(1.543)	13.1 (.516)									
	5/16	8	FVD14-8		8.4 (.331)	15.3 (.602)	42.4(1.669)	14.7 (.579)									
	3/8	10	FVD14-10		10.5 (.413)	15.3 (.602)	42.4(1.669)	14.7 (.579)									
4 (16.78 to 26.66)	1/4	6	FVD22-6		6.4 (.252)	13.8 (.543)	44.0(1.732)	14.1 (.555)	12.0 (.472)	23.0 (.906)	7.2 (.284)	11.5 (.453)	1.3 (.051)	Yellow	YF-1 YNE-38 E-4	100	
	5/16	8	FVD22-8		8.4 (.331)	15.9 (.626)	46.1(1.815)	15.1 (.594)									
	3/8	10	FVD22-10		10.5 (.413)	15.9 (.626)	46.1(1.815)	15.1 (.594)									
2 (26.66 to 42.42)	1/4	6	FVD38-6		6.4 (.252)	17.5 (.689)	51.1(2.012)	17.3 (.681)	13.5 (.531)	25.0 (.984)	9.1 (.358)	13.3 (.524)	1.4 (.055)	Red	YF-1 YNE-38 E-4	100	
	5/16	8	FVD38-8		8.4 (.331)	17.5 (.689)	51.1(2.012)	17.3 (.681)									
	3/8	10	FVD38-10		10.5 (.413)	17.5 (.689)	51.1(2.012)	17.3 (.681)									
	7/16	12	FVD38-12		13.0 (.512)	19.9 (.784)	55.4(2.181)	20.4 (.803)									

Note:1) Delivery lead times may vary depending on the product. Contact JST for details.