

557-109 EMI/RFI Banding Backshell Assembly for MIL-C-24308 Connectors

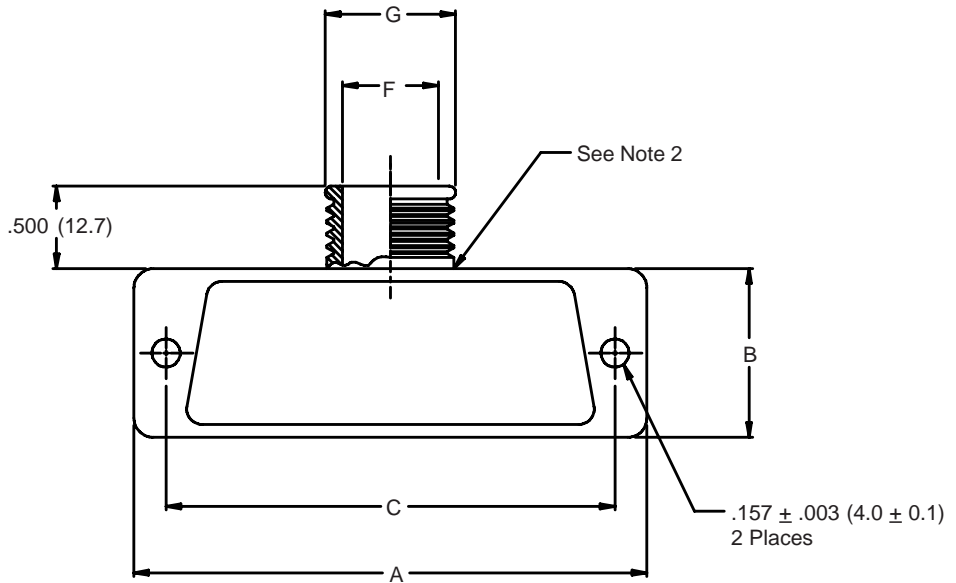
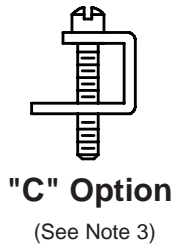
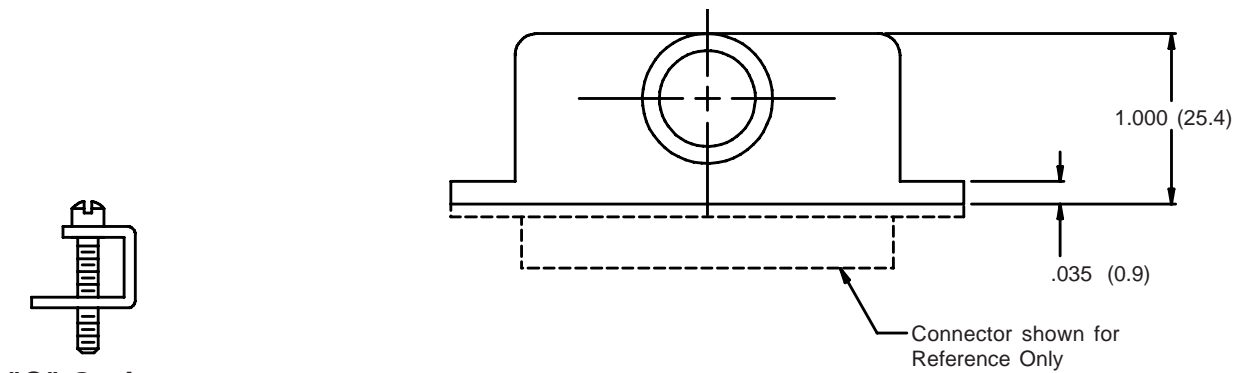
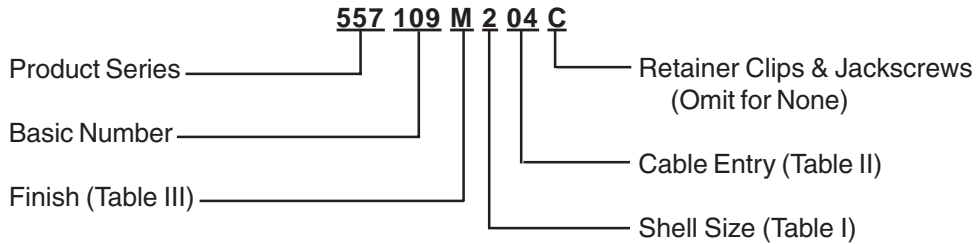

NOTES:

1. Metric dimensions (mm) are indicated in parentheses.
2. End Fitting may be brazed on per MIL-B-7883B, Type V, Grade B.
3. See 687-316 for Jackscrew Hardware

557-109
EMI/RFI Banding Backshell Assembly
for MIL-C-24308 Connectors



MIL-C-24308
D-Subminiature

TABLE I: CONNECTOR INTERFACE DIMS

Shell Size	A	B	C ±.005 (0.1)
1	1.203 (30.6)	.500 (12.7)	.984 (25.0)
2	1.531 (38.9)	.500 (12.7)	1.312 (33.3)
3	2.078 (52.8)	.500 (12.7)	1.852 (47.0)
4	2.718 (69.0)	.500 (12.7)	2.500 (63.5)
5	2.625 (66.7)	.609 (15.5)	2.406 (61.1)

TABLE II: CABLE ENTRY

Dash No.	F Dia	G Dia
01	.125 (3.2)	.205 (5.2)
02	.187 (4.7)	.267 (6.8)
03	.270 (6.9)	.350 (8.9)
04	.290 (7.4)	.370 (9.4)
05	.312 (7.9)	.392 (10.0)
06	.395 (10.0)	.475 (12.1)
07	.420 (10.7)	.500 (12.7)
08	.500 (12.7)	.580 (14.7)
09	.529 (13.4)	.609 (15.5)

**TABLE III:
FINISH OPTIONS**

Symbol	Finish
B	Cadmium Plate/Olive Drab
C*	Black Anodize
G*	Anodic Hard Coat
J	Gold Iridite over Cadmium Plate over Electroless Nickel
LF	Cadmium Plate/Bright over Electroless Nickel
M	Electroless Nickel
N	Cadmium Plate/Olive Drab over Electroless Nickel
NC	Zinc Cobalt/Dark Olive Drab
NF	Cadmium Plate/Olive Drab over Electroless Nickel
T	Cadmium Plate/Bright over Electroless Nickel
U**	Cadmium Plate/Black
ZN	Zinc-Nickel Alloy/Olive Drab

*Anodize finish is not suitable for EMI shielding or grounding applications.

**Applicable to corrosion resisting steel backshells and accessories. Consult factory for other available finishes.

Metric dimensions (mm) are indicated in parentheses