

Features

- Output Current: Up to 1.5A
- Output Voltages: 1.2V, 1.5V, 1.8V, 2.5V, 3.3V and 5.0V
- Stable with a Ceramic Output Capacitor
- Dropout Voltage: 400mV @ 1.5A
- Low Quiescent Current
- Over Temperature Shutdown
- Short Circuit Protection
- Low Temperature Coefficient
- Pb-Free Package

Applications

- DSP, FPGA and Microprocessor Power Supplies
- SATA Power Supply
- LCD TV/Monitors
- Wireless Devices
- Communication Devices
- Portable Electronics
- Post Regulator for SMPS

General Description

The PAM3110 is a 1.5A CMOS LDO regulator that features a low quiescent current and low dropout voltages, as well as over temperature shutdown. The fixed output voltage of the PAM3110 is set at the factory and trimmed to $\pm 1.5\%$. The PAM3110 is stable with a ceramic output capacitor of $4.7\mu\text{F}$ or higher.

This family of regulators can provide either a stand-alone power supply solution or act as a post regulator for switch mode power supplies. They are particularly suitable for applications requiring low input and output voltages.

PAM3110 is available in SOT-223, TO-252 and TO-263-2L package.

Typical Application Circuit

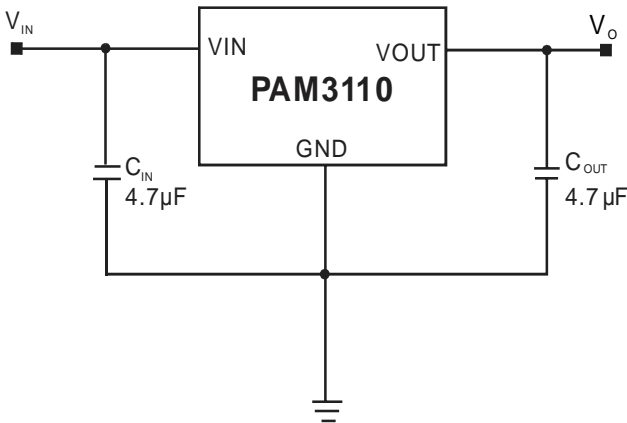

Block Diagram

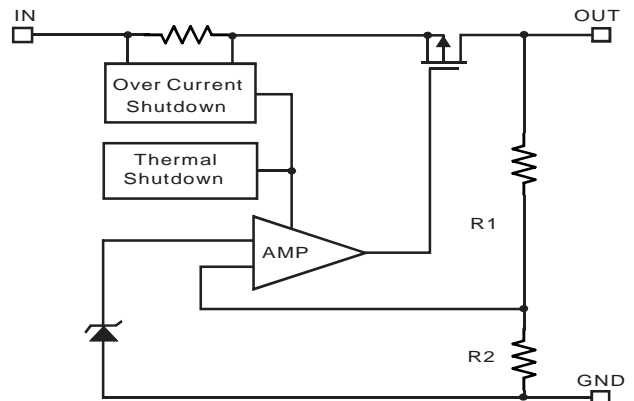

Pin Configuration & Marking Information

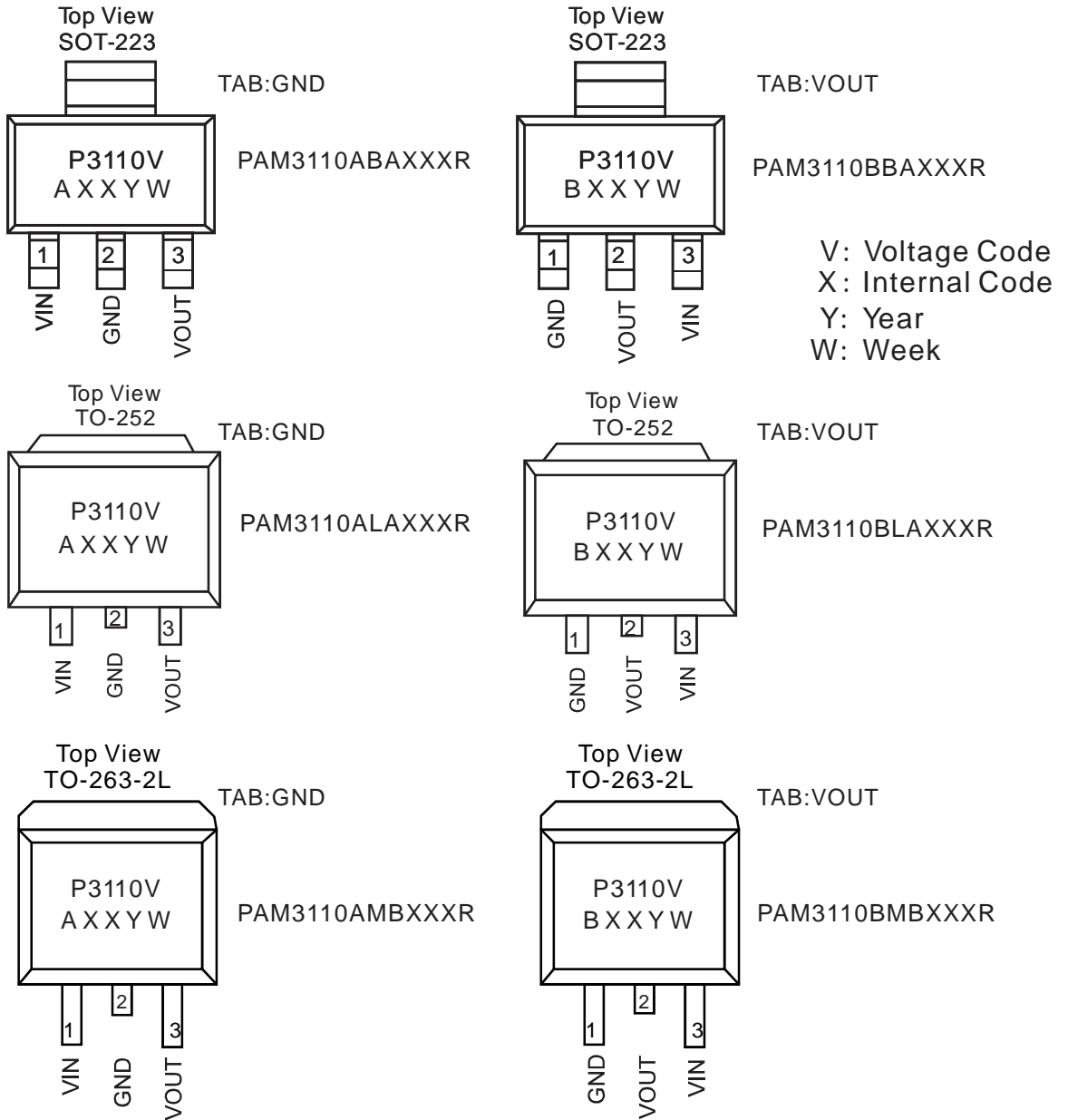



Absolute Maximum Ratings

These are stress ratings only and functional operation is not implied. Exposure to absolute maximum ratings for prolonged time periods may affect device reliability. All voltages are with respect to ground.

Input Voltage.....6V	Maximum Junction Temperature.....150°C
Storage Temperature.....-65°C to 150°C	Lead Soldering Temperature (5sec).....300°C

Recommended Operating Conditions

Supply Voltage Range.....2.5V to 5.5V	Ambient Temperature Range.....-40°C to 85°C
	Junction Temperature Range.....-40°C to 125°C

Thermal Information

Parameter	Symbol	Package	Maximum	Unit
Thermal Resistance (Junction to Case)	θ_{JC}	SOT-223	7	°C/W
		TO-252	7	
		TO-263	7	
Thermal Resistance (Junction to Ambient)	θ_{JA}	SOT-223	160	°C/W
		TO-252	90	
		TO-263	60	
Internal Power Dissipation @ TA=25°C	P _D	SOT-223	625	mW
		TO-252	1200	
		TO-263	2000	



Electrical Characteristic

$V_{IN}=V_O+0.5V$, $T_A=25^{\circ}C$, $C_{IN}=4.7\mu F$, $C_{OUT}=4.7\mu F$, unless otherwise noted.

Parameters	Symbol	Test Conditions	MIN	TYP	MAX	UNITS
Input Voltage Range	V_{IN}		2.5		5.5	V
Output Voltage Accuracy	V_O	$I_o=100mA$	-1.5		1.5	%
Dropout Voltage	V_{DROP}	$I_o=500mA$ $V_o \geq 2.5V$		200		mV
		$I_o=1.5A$ $V_o \geq 2.5V$		400		
Short Circuit Current	I_{SC}	$V_o < 0.3V$		500		mA
Quiescent Current	I_Q	$I_o=0mA$		75	150	μA
Current Limit	I_{LIM}			2		A
Line Regulation	LNR	$V_o \leq 2.5V$, $I_o=10mA$ $V_{IN}=V_o+1.5V$ to $V_o+2.5V$		0.5	1	%V
		$V_o > 2.5V$, $I_o=10mA$ $V_{IN}=V_o+0.5V$ to $V_o+1.5V$				
Load Regulation	LDR	$I_o=1mA$ to $100mA$		0.5	1	%
Over Temperature Shutdown	OTS			160		$^{\circ}C$
Over Temperature Hysteresis	OTH			30		$^{\circ}C$
Temperature Coefficient	TC			40		ppm/ $^{\circ}C$
Power Supply Ripple Rejection	PSRR	$I_o=100mA$	$f=100Hz$		55	dB
			$f=1kHz$		50	
			$f=10kHz$		35	

Typical Performance Characteristics

$T_A=25^{\circ}\text{C}$, $C_{IN}=4.7\mu\text{F}$, $C_{OUT}=4.7\mu\text{F}$, unless otherwise noted.

1. Output Voltage vs Input Voltage

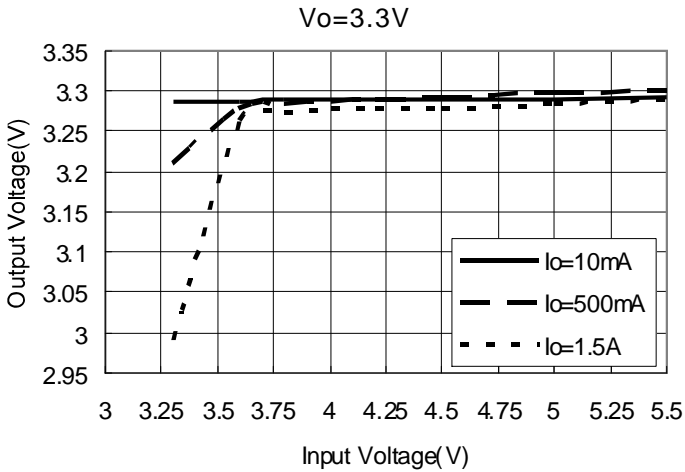

2. Output Voltage vs Output Current

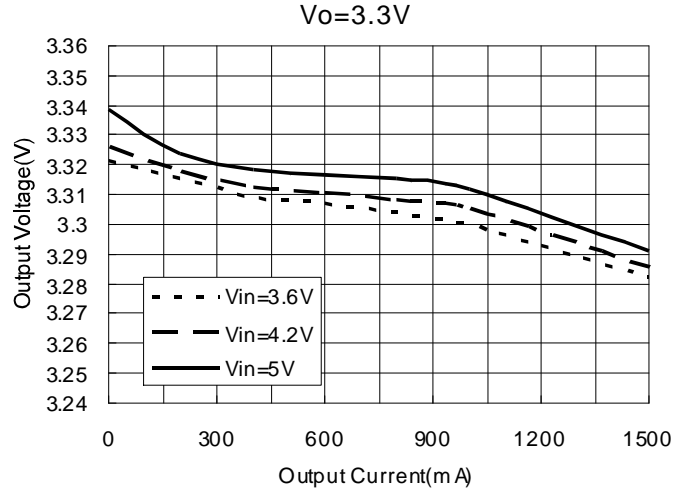

3. Quiescent Current vs Input Voltage

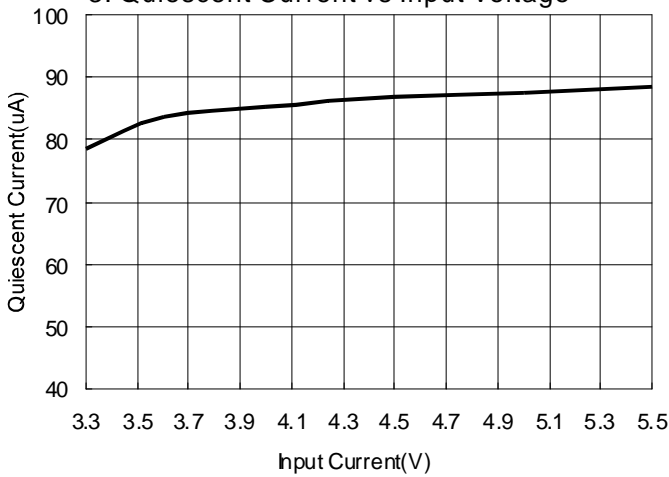

4. Quiescent Current vs Temperature

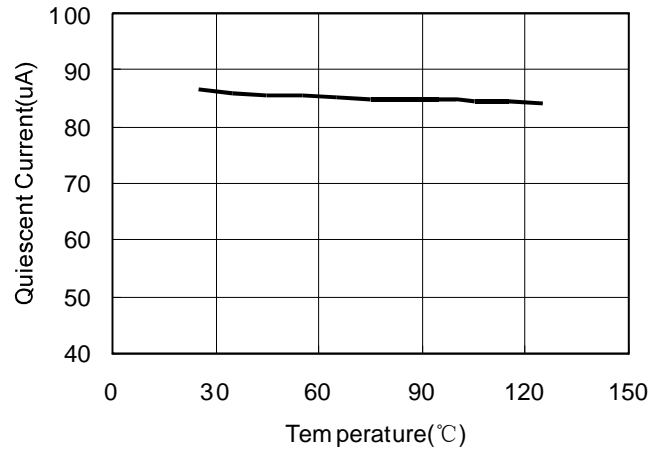

5. Maximum Output Current vs Input Voltage

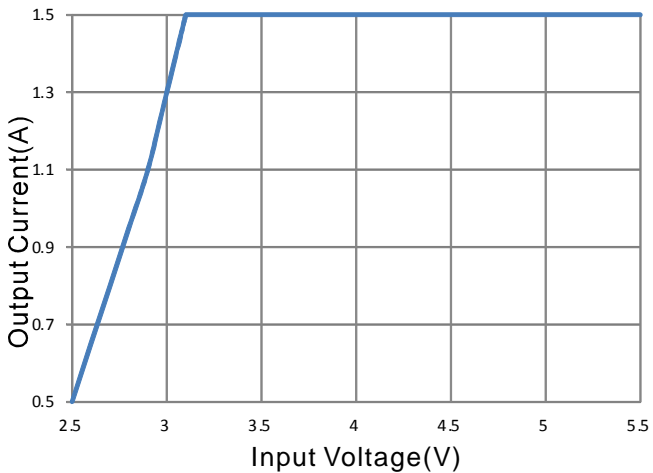

Typical Performance Characteristics

$T_A=25^\circ\text{C}$, $C_{IN}=4.7\mu\text{F}$, $C_{OUT}=4.7\mu\text{F}$, unless otherwise noted.

6. Safety Operation Area

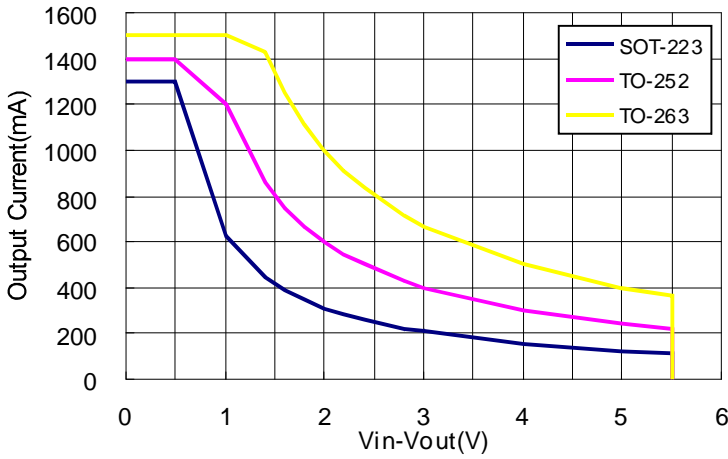

7. Ripple Rejection vs Frequency

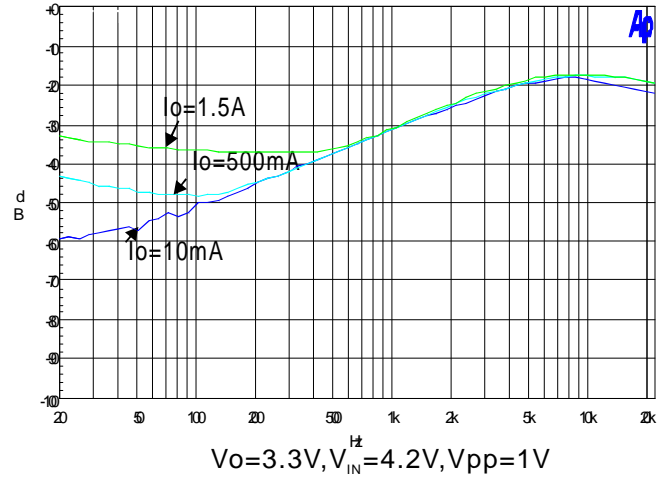

8. Load Transient Response



$V_o=3.3\text{V}$, $V_{IN}=5\text{V}$, $I_o=0\text{mA}$ to 1.5A

9. Line Transient Response

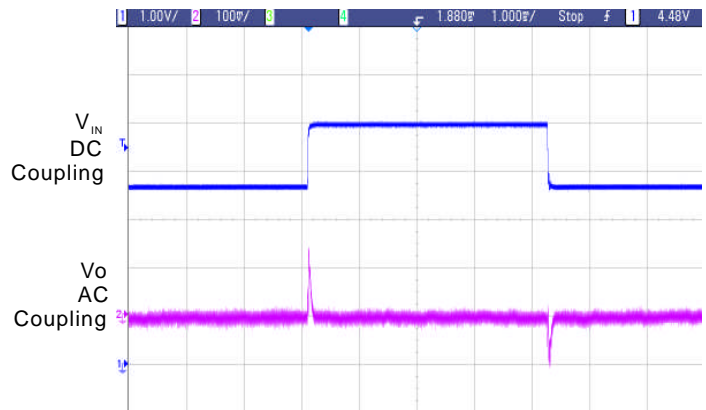

$V_o=3.3\text{V}$, $V_{IN}=3.8\text{V}$ to 5V , $I_o=10\text{mA}$

Application Information

The PAM3110 family of low-dropout (LDO) regulators have several features that allow them to apply to a wide range of applications. The family operates with very low input voltage and low dropout voltage (typically 300mV at full load), making it an efficient stand-alone power supply or post regulator for battery or switch mode power supplies. The 1.5A output current make the PAM3110 family suitable for powering many microprocessors and FPGA supplies.

External Capacitor Requirements

A 4.7µF or larger ceramic input bypass capacitor, connected between V_{IN} and GND and located close to the PAM3110, is required for stability. A 4.7µF minimum value capacitor from V_O to GND is also required. To improve transient response, noise rejection, and ripple rejection, an additional 10µF or larger, low ESR capacitor is recommended at the output. A higher-value, low ESR output capacitor may be necessary if large, fast-rise-time load transients are anticipated and the device is located several inches from the power source, especially if the minimum input voltage of 2.5 V is used.

Regulator Protection

The PAM3110 features internal current limiting, thermal protection and short circuit protection. During normal operation, the PAM3110 limits output current to about 2A. When current limiting engages, the output voltage scales back linearly until the over current condition ends. While current limiting is designed to prevent gross device failure, care should be taken not to exceed the power dissipation ratings of the package. If the temperature of the device exceeds 150°C, thermal-protection circuitry will shut down. Once the device has cooled down to approximately 30°C below the high temp trip point, regulator operation resumes. The short circuit current of the PAM3110 is about 0.5A when its output pin is shorted to ground.

Thermal Information

The amount of heat that an LDO linear regulator generates is:

$$P_D = (V_{IN} - V_O) I_O$$

All integrated circuits have a maximum allowable junction temperature ($T_J \text{ max}$) above which normal operation is not assured. A system designer must design the operating environment so that the operating junction temperature (T_J) does not exceed the maximum junction temperature ($T_J \text{ max}$). The two main environmental variables that a designer can use to improve thermal performance are air flow and external heatsinks. The purpose of this information is to aid the designer in determining the proper operating environment for a linear regulator that is operating at a specific power level.

In general, the maximum expected power ($P_D(\text{max})$) consumed by a linear regulator is computed as:

$$P_{D\text{MAX}} = (V_{I(\text{avg})} - V_{O(\text{avg})}) \times I_{O(\text{avg})} + V_{I(\text{avg})} \times I_{(Q)}$$

Where:

- $V_{I(\text{avg})}$ is the average input voltage.
- $V_{O(\text{avg})}$ is the average output voltage.
- $I_{O(\text{avg})}$ is the average output current.
- $I_{(Q)}$ is the quiescent current.

For most LDO regulators, the quiescent current is insignificant compared to the average output current; therefore, the term $V_{I(\text{avg})} \times I_{(Q)}$ can be neglected. The operating junction temperature is computed by adding the ambient temperature (T_A) and the increase in temperature due to the regulator's power dissipation. The temperature rise is computed by multiplying the maximum expected power dissipation by the sum of the thermal resistances between the junction and the case ($R_{\theta JC}$), the case to heatsink ($R_{\theta CS}$), and the heatsink to ambient ($R_{\theta SA}$). Thermal resistances are measures of how effectively an object dissipates heat. Typically, the larger the device, the more surface area available for power dissipation so that the object's thermal resistance will be lower.



Ordering Information

PAM3110X X X xxx X

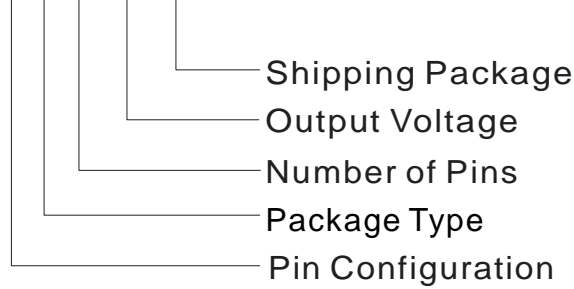

Pin Configuration	Package Type	Number of Pins	Output Voltage
A Type	B: SOT-223	A: 3	120: 1.2V
1. VIN	L: TO-252	B: 2	150: 1.5V
2. GND	M: TO-263		180: 1.8V
3. VOUT			250: 2.5V
B Type			330: 3.3V
1. GND			500: 5.0V
2. VOUT			
3. VIN			

(To be cont'd)



PAM3110

1.5A Low Dropout Voltage CMOS Regulator

Ordering Information

Part Number	Output Voltage	Marking	Package Type	MOQ & Shipping Pckage
PAM3110ABA120R	1.2V	P3110B AXXYW	SOT-223	2,500 Units/Tapes & Reel
PAM3110BBA120R	1.2V	P3110B BXXYW	SOT-223	2,500 Units/Tapes & Reel
PAM3110ALA120R	1.2V	P3110B AXXYW	TO-252	2,500 Units/Tapes & Reel
PAM3110BLA120R	1.2V	P3110B BXXYW	TO-252	2,500 Units/Tapes & Reel
PAM3110AMB120R	1.2V	P3110B AXXYW	TO-263-2L	800 Units/Tapes & Reel
PAM3110BMB120R	1.2V	P3110B BXXYW	TO-263-2L	800 Units/Tapes & Reel
PAM3110ABA150R	1.5V	P3110C AXXYW	SOT-223	2,500 Units/Tapes & Reel
PAM3110BBA150R	1.5V	P3110C BXXYW	SOT-223	2,500 Units/Tapes & Reel
PAM3110ALA150R	1.5V	P3110C AXXYW	TO-252	2,500 Units/Tapes & Reel
PAM3110BLA150R	1.5V	P3110C BXXYW	TO-252	2,500 Units/Tapes & Reel
PAM3110AMB150R	1.5V	P3110C AXXYW	TO-263-2L	800 Units/Tapes & Reel
PAM3110BMB150R	1.5V	P3110C BXXYW	TO-263-2L	800 Units/Tapes & Reel
PAM3110ABA180R	1.8V	P3110E AXXYW	SOT-223	2,500 Units/Tapes & Reel
PAM3110BBA180R	1.8V	P3110E BXXYW	SOT-223	2,500 Units/Tapes & Reel
PAM3110ALA180R	1.8V	P3110E AXXYW	TO-252	2,500 Units/Tapes & Reel
PAM3110BLA180R	1.8V	P3110E BXXYW	TO-252	2,500 Units/Tapes & Reel
PAM3110AMB180R	1.8V	P3110E AXXYW	TO-263-2L	800 Units/Tapes & Reel
PAM3110BMB180R	1.8V	P3110E BXXYW	TO-263-2L	800 Units/Tapes & Reel
PAM3110ABA250R	2.5V	P3110G AXXYW	SOT-223	2,500 Units/Tapes & Reel
PAM3110BBA250R	2.5V	P3110G BXXYW	SOT-223	2,500 Units/Tapes & Reel
PAM3110ALA250R	2.5V	P3110G AXXYW	TO-252	2,500 Units/Tapes & Reel
PAM3110BLA250R	2.5V	P3110G BXXYW	TO-252	2,500 Units/Tapes & Reel
PAM3110AMB250R	2.5V	P3110G AXXYW	TO-263-2L	800 Units/Tapes & Reel
PAM3110BMB250R	2.5V	P3110G BXXYW	TO-263-2L	800 Units/Tapes & Reel



Ordering Information

Part Number	Output Voltage	Marking	Package Type	MOQ & Shipping Pckage
PAM3110ABA330R	3.3V	P3110K AXXYW	SOT-223	2,500 Units/Tapes&Reel
PAM3110BBA330R	3.3V	P3110K BXXYW	SOT-223	2,500 Units/Tapes&Reel
PAM3110ALA330R	3.3V	P3110K AXXYW	TO-252	2,500 Units/Tapes&Reel
PAM3110BLA330R	3.3V	P3110K BXXYW	TO-252	2,500 Units/Tapes&Reel
PAM3110AMB330R	3.3V	P3110K AXXYW	TO-263-2L	800 Units/Tapes&Reel
PAM3110BMB330R	3.3V	P3110K BXXYW	TO-263-2L	800 Units/Tapes&Reel
PAM3110ABA500R	5.0V	P3110L AXXYW	SOT-223	2,500 Units/Tapes&Reel
PAM3110BBA500R	5.0V	P3110L BXXYW	SOT-223	2,500 Units/Tapes&Reel
PAM3110ALA500R	5.0V	P3110L AXXYW	TO-252	2,500 Units/Tapes&Reel
PAM3110BLA500R	5.0V	P3110L BXXYW	TO-252	2,500 Units/Tapes&Reel
PAM3110AMB500R	5.0V	P3110L AXXYW	TO-263-2L	800 Units/Tapes&Reel
PAM3110BMB500R	5.0V	P3110L BXXYW	TO-263-2L	800 Units/Tapes&Reel

Outline Dimension

SOT-223

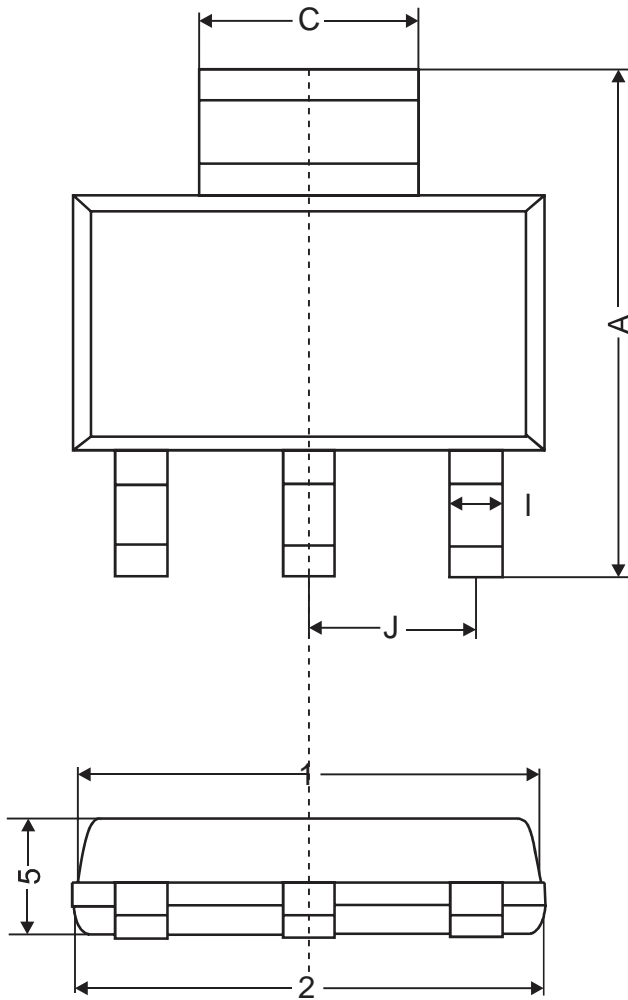

Dimensions (Millimeter)			
Symbol	MIN	NOM	MAX
A	6.70	7.00	7.30
C	2.90	3.00	3.10
D	0.02	0.06	0.10
E	0°	5°	10°
I	0.60	0.70	0.80
H	0.25	0.30	0.35
B	13° TYP		
J	2.30REF		
1	6.30	6.50	6.70
2	6.30	6.50	6.70
3	3.30	3.50	3.70
4	3.30	3.50	3.70
5	1.40	1.60	1.80

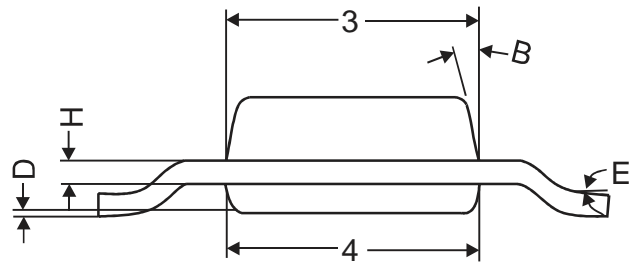

Outline Dimension

TO-252

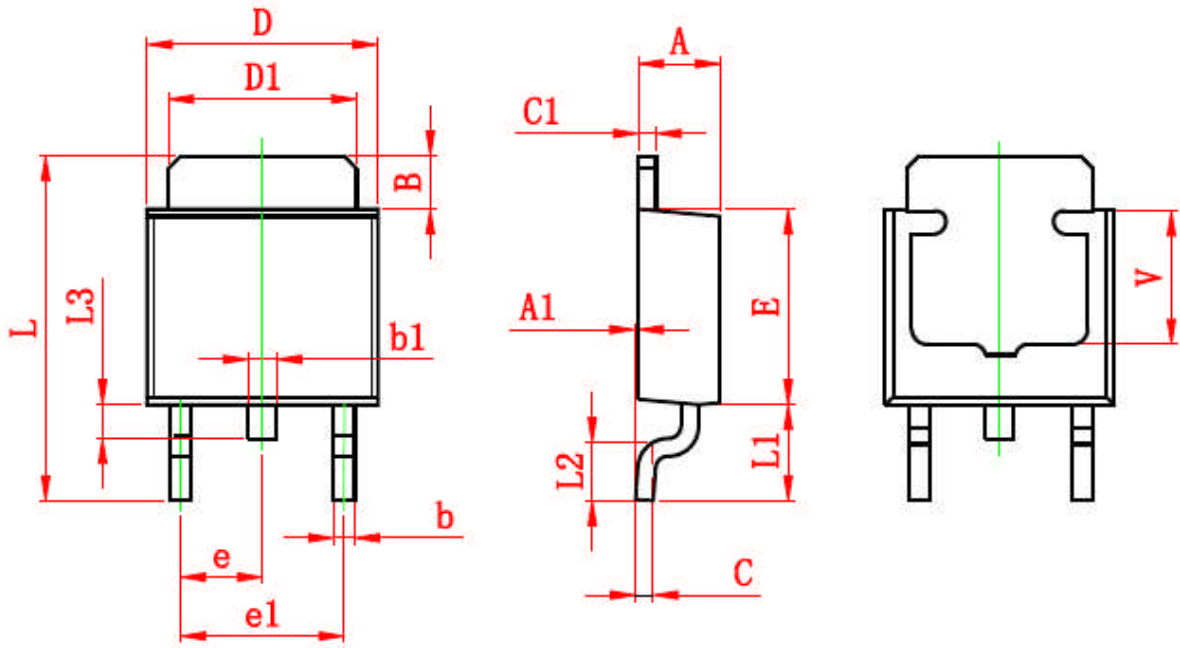

Symbol	Dimensions In Millimeters		Dimensions In Inches	
	Min.	Max.	Min.	Max.
A	2.200	2.400	0.087	0.094
A1	0.000	0.127	0.000	0.005
B	1.350	1.650	0.053	0.065
b	0.500	0.700	0.020	0.028
b1	0.700	0.900	0.028	0.035
c	0.430	0.580	0.017	0.023
c1	0.430	0.580	0.017	0.023
D	6.350	6.650	0.250	0.262
D1	5.200	5.400	0.205	0.213
E	5.400	5.700	0.213	0.224
e	2.300 TYP.		0.091 TYP.	
e1	4.500	4.700	0.177	0.185
L	9.500	9.900	0.374	0.390
L1	2.550	2.900	0.100	0.114
L2	1.400	1.780	0.055	0.070
L3	0.600	0.900	0.024	0.035
V	3.800 REF.		0.150 REF.	

Outline Dimension

TO-263-2L

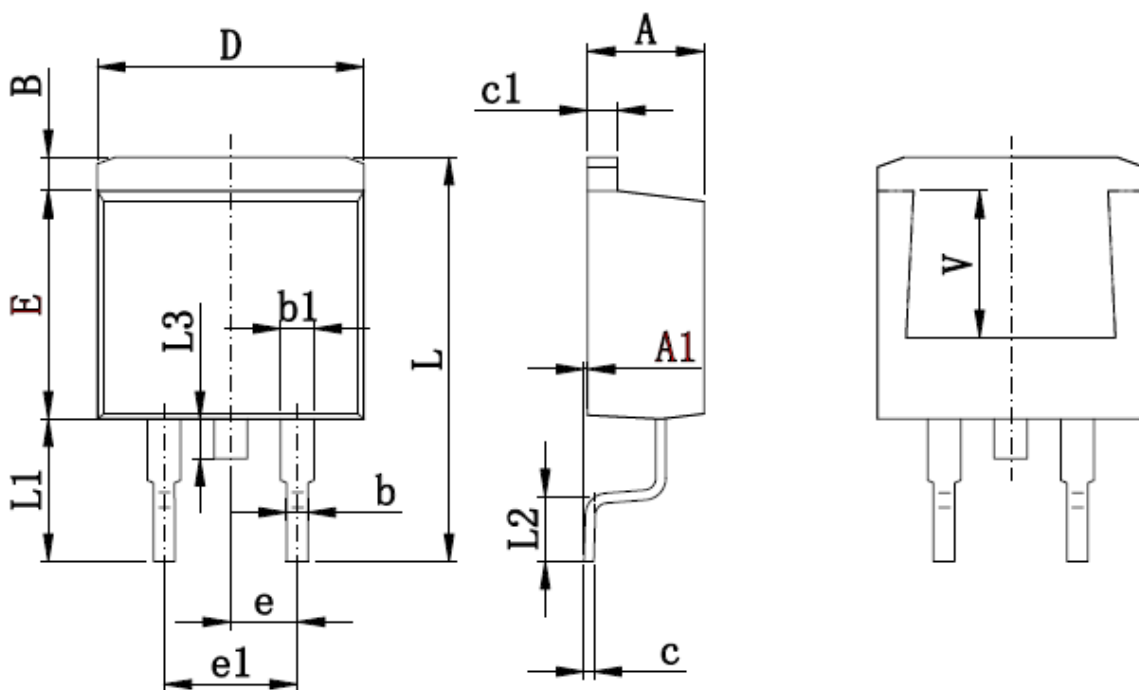

Symbol	Dimensions In Millimeters		Dimensions In Inches	
	Min	Max	Min	Max
A	4.470	4.670	0.176	0.184
A1	0.000	0.150	0.000	0.006
B	1.170	1.370	0.046	0.054
b	0.710	0.910	0.028	0.036
b1	1.170	1.370	0.046	0.054
c	0.310	0.530	0.012	0.021
c1	1.170	1.370	0.046	0.054
D	10.010	10.310	0.394	0.406
E	8.500	8.900	0.335	0.350
e	2.540 TYP		0.100 TYP	
e1	4.980	5.180	0.196	0.204
L	15.050	15.450	0.593	0.608
L1	5.080	5.480	0.200	0.216
L2	2.340	2.740	0.092	0.108
L3	1.300	1.700	0.051	0.067
V	5.600 REF		0.220 REF	