

## 200 Series Heavy Duty

### Product Facts

- n Choose from 5 different contact styles.
- n 600 volt UL and NEMA rating.
- n Conservatively rated from 50 to 90 amperes per circuit, depending on which contact style is selected.
- n Choose any of three mounting methods — two-way flat base models surface mount directly to the panel or snap-on miniature channel. Dovetail base models mount on standard channel.
- n Packaged for rapid handling and assembly — snap-fit sections are packed 10 per carton.
- n Only one end section needed per block assembly.
- n Readily identify circuits — mark directly on block sections or use removable marking strip. Pre-printed strips are also available.

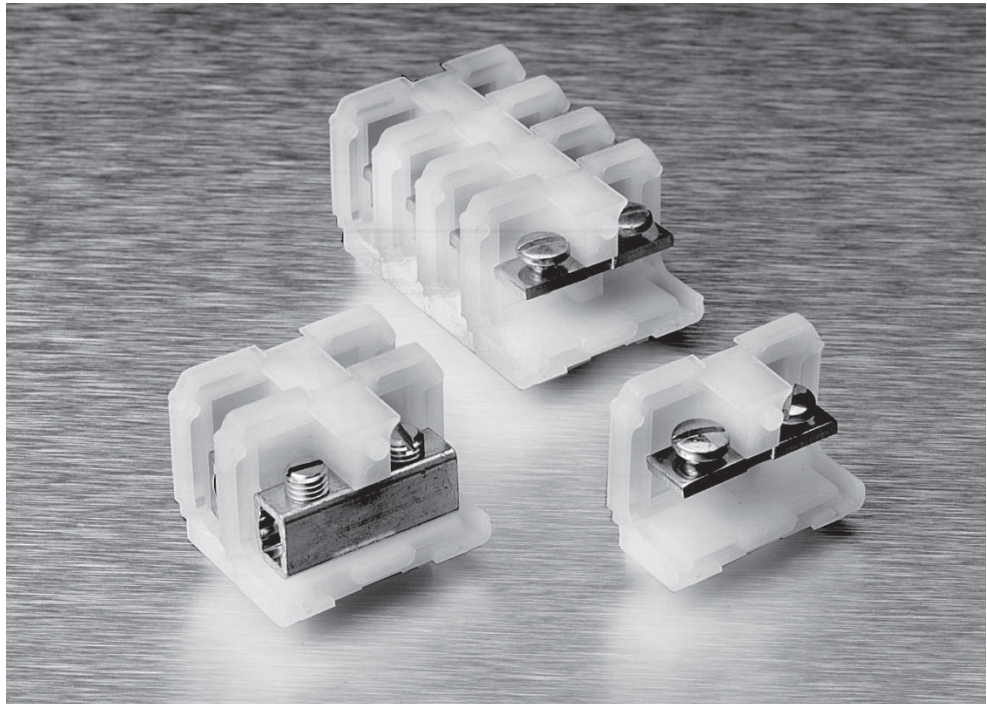

This compact, heavy duty block line accepts single or combination wires up to #4 AWG, solid or stranded. The compact design allows at least 138 circuits per 6-foot length to be mounted. The pitch of this 600 volt block is 0.50" [12.70] (centerline spacing).



**Note:** All part numbers are RoHS Compliant.

**200 Series, Heavy Duty, 600V, 0.50" [1.27] Pitch**

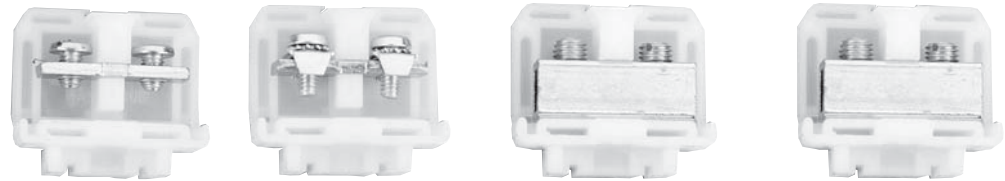

**Characteristics**                      **Strap Screw**                      **Strap Clamp**                      **Tubular Screw**                      **Tubular Clamp**

Type of Block	Model	Part Number	Model	Part Number	Model	Part Number	Model	Part Number
<b>Direct Mount (Flat Base)</b>								
Nylon, Unpainted	241	3-1437390-9	248	4-1437390-2	242	4-1437390-0	243	4-1437390-1
Polypropylene	P241	6-1437390-5	P248	6-1437390-8	P242	6-1437390-6	P243	6-1437390-7
<b>Channel Mount (Dovetail Base)</b>								
Nylon, Painted	0241	1-1437390-6	0248	2-1437390-4	0242	2-1437390-0	0243	2-1437390-1
Polypropylene	P0241	5-1437390-9	P0248	6-1437390-3	P0242	6-1437390-0	P0243-BU	6-1437390-2
<b>Contact Type</b>								



**Specifications**

Wire Range (AWG) Solid & Stranded	22-10	18-8	18-4	18-6
Wire Strip Length (in.)	—	1/2	1/2	1/2
Screw Type	10-32 binding head	8-32 pan head	1/4-28 set screw	1/4-28 set screw
Ampacity	35 A	50 A	85 A	65 A

**End Sections**

Direct Mount, Nylon	250	4-1437390-3	250	4-1437390-3	250	4-1437390-3	250	4-1437390-3
Direct Mount, Polypropylene	P250	6-1437390-6	P250	6-1437390-6	P250	6-1437390-6	P250	6-1437390-6
Channel Mount, Nylon	0250	2-1437390-5	0250	2-1437390-5	0250	2-1437390-5	0250	2-1437390-5
Channel Mount, Polypropylene	P0250	6-1437390-4	P0250	6-1437390-4	P0250	6-1437390-4	P0250	6-1437390-4

**Notes:**

For factory assembled blocks, suffix Catalog Number with number of blocks desired. See page 264-266 for dimensions and other details. (Maximum number of flat base preassembled sections is 12).  
Example: Ten tubular clamp, dovetail based sections, preassembled on channel = 024310

Example: Twelve polypropylene strap clamp flat base sections = P24812

For unpainted factory assembled blocks supplied with a removable marking strip add — 1 to Catalog Number.

For blocks with two or more different contact sections, imprinted marking strips, or special features, consult Technical Support.

**Comparison (Type of Block)**



**Direct Mount (Flat Base)**



**Channel Mount (Dovetail Base)**



LR25557



E63810

**Note:** All part numbers are RoHS Compliant.

**200 Series, Heavy Duty, 600V, 0.50" [1.27] Pitch** (Continued)





**Corrosion Resistant Strap Screw**



**Corrosion Resistant Tubular Screw**

Model	Part Number	Model	Part Number
D241	4-1437389-0	D242	4-1437389-1
DP241	1776721-1	DP242	1776723-1
D0241	1776722-1	D0242	1776724-1
DP0241	6-1437389-0	DP0242	1776724-2

	
22-10	18-4
—	1/2
10-32 Nickel plated binding head	1/4-28 Nickel plated set screw
35 A	85 A

  

250	4-1437390-3	250	4-1437390-3
P250	6-1437390-6	P250	6-1437390-6
O250	2-1437390-5	O250	2-1437390-5
P0250	6-1437390-4	P0250	6-1437390-4



## 200 Series Heavy Duty Accessories

### Mounting Channel

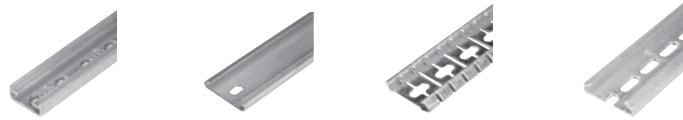

Miniature		Steel Channel		Break Away Steel		Pre-punched Aluminum Channel	
Part Number	Catalog Number	Part Number	Catalog Number	Part Number	Catalog Number	Part Number	Catalog Number
1437381-8	12	9-1437381-1 9-1437381-8	60 63-BU	9-1437381-2	60-B-36	9-1437381-9 1437382-2	64 67
<b>Standard Length</b>							
3 feet		6 feet 3 feet		3 feet		6 feet 3 feet	

### Channel Clamps

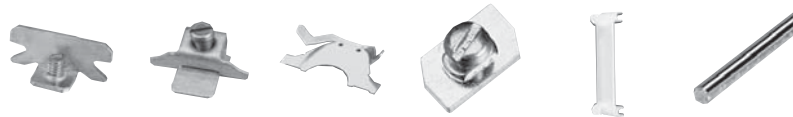

Screw Channel Clamps	Universal Clamps	Snap-In Clamps	Miniature for #12 Channel	See-thru Cover	Ganging Rod
<b>Part Number</b>					
9-1437381-5	1437382-3	9-1437381-7	1437381-4	1-1437381-6	3-1437381-9
<b>Catalog Number</b>					
61	68	62	11	23-BU	30-BU
<b>Standard Length</b>					
—	—	—	—	—	2 feet

### Marking Accessories



### Jumpers



Plastic Cloth Tape	Plastic Cloth Tape	Vinyl Marking Strips	Elevated Marking Strip	Nylon Holding Plug	Jumper for Tubular Contacts	Snap-Apart for Tubular Contacts
<b>Part Number</b>						
8-1437381-1	8-1437381-0	6-1437381-3	4-1437391-1	4-1437393-0	2-1437393-4	1-1437382-5
<b>Catalog Number</b>						
56	55-BU	50-BU	52-BU	65-BU	42-BU	75
<b>Standard Length</b>						
—	50 feet	25 feet	18 inches	—	—	12 ckt

### Related Product Data

**Wire Pins and Ferrules**—Pages 109-111  
For more information on AMP Standard Terminals and Splices or Quick-Connect FASTON Receptacles and Tabs, request Catalog 82042.



**Note:** All part numbers are RoHS Compliant.

## 200 Series Heavy Duty Specifications

### Material & Finish

**Voltage Rating:** Blocks meet 600 volt creepage and clearance requirements of NEMA, UL and CSA for general industrial control equipment and panelboards. Withstand voltages greatly in excess of IEEE switchgear standards for 750 volts.

**Ampacity:** For a single #4 AWG wire the maximum amperage recommended is 85 amps.

### Standard Contacts:

**Material:** Electrical grade copper or copper alloy conductor. Steel Screws plated to resist corrosion in most industrial applications

**AL-CU Tubular Screw:** Aluminum compatibility with aluminum or copper conductors. AL-CU is tin-plated brass.

### Environmental Contacts (for highly corrosive atmospheres)

**Tubular Screw:** Electrical grade copper tube with nickel plating. Nickel plated brass screws.

**Strap Screw:** Nickel plated brass straps and screws. Nickel plating exceeds specification QQ-N-290 Class I, Type VII.

### Nylon Housing:

**Material**—Nylon; Unfilled Type 6/6

**Max. Continuous Temperature**—125°C [257°F]

### Breakdown Voltage (AC, 60 Hz)

Contact-to-Contact: 7000V

Contact-to-Ground: 7800V

**Dielectric Strength (RH 40% at Sea Level)**—470-385 Volts/mil thickness Per ASTM D149

**UL High Voltage Arc Tracking (inches/min.)**—.01-.35

**Water Absorption (24 hrs. % wt. gain)**—1.5%

**Flammability**—UL94V-2

**Chemical Resistance**—Resistant to aromatic hydrocarbons, strong alkalis Per ASTM D543

**Radiation Resistance (ergs g-1 (C))**—8 x 10<sup>7</sup>

**Color**—Translucent White

### Independent Testing Service Listing and Recognition

WIRE SIZES, Solid or Stranded

Tubular Screw

1 #4 AWG, 1 #6 AWG,

1 or 2 #8 AWG, 1 to 4 #10 AWG,

1 or 5 #12 AWG, 1 to 4 #14 AWG,

1 or 6 #16 AWG, 1 to 8 #18 AWG,

Tubular Clamp

1 #6 AWG, 1 or 2 #8 AWG,

1 to 3 #10 AWG, 1 to 4 #12 AWG,

1 or 4 #14 AWG, 1 to 6 #16 AWG,

1 or 8 #18 AWG

Strap Clamp

1 #18 to 1 #8 AWG

### Polypropylene Housing:

**Material**—Polypropylene; Filled self-extinguishing

**Max. Continuous Temperature**—105°C (221°F)

### Breakdown Voltage (AC, 60Hz)

Contact-to-Ground: 7800V

Contact-to-Contact: 7000V

**Dielectric Strength (RH 40% at Sea Level)**—500 Volts/mil thickness Per ASTM D149

**UL High Voltage Arc Tracking (inches/min.)**—Did not Track

**Water Absorption (24 hrs. % wt. gain)**—0.02% Per ASTM D570

**Flammability**—UL94V-0

**Chemical Resistance**—Resistant to most acids, alkalines, and saline solutions. Also resistant to higher aliphatic solvents and polar substances per ASTM D543

**Radiation Resistance (ergs g-1 (C))**—No data Available

**Color**—Opaque White



LR25557



E63810

**Note:** All part numbers are RoHS Compliant.

**200 Series, 600 Volt, Direct Mount**

**Flat Base**

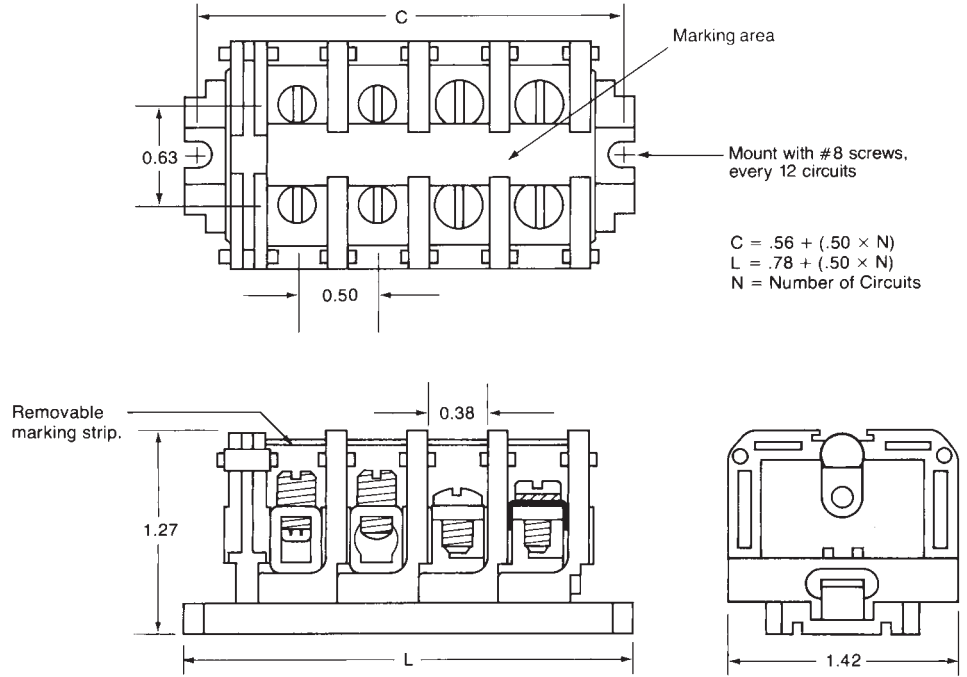

**Note:** All part numbers are RoHS Compliant.

**200 Series, 600 Volt, Channel Mount**

**Flat Base Mounted On #12 Miniature Channel**

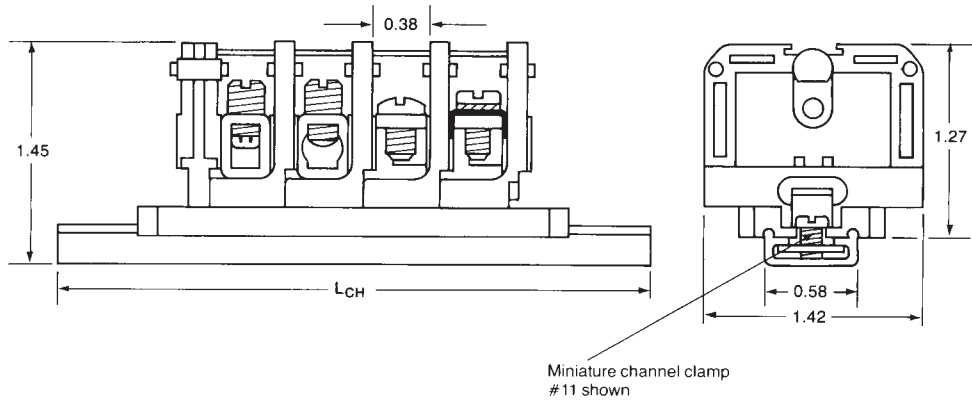
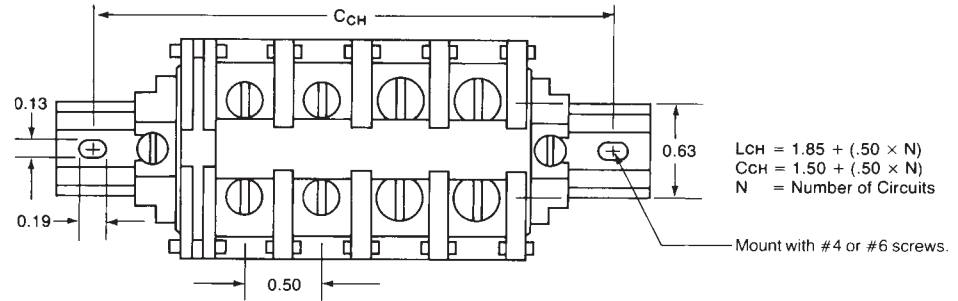

NEMA Terminal Blocks **6**

**Note:** All part numbers are RoHS Compliant.

**200 Series, 600 Volt, Channel Mount (Standard)**

**Dovetail Base Mounted On Standard #60 Channel**

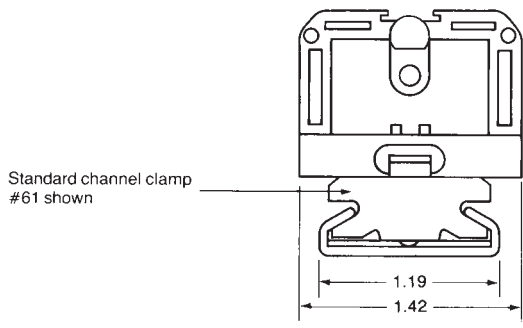
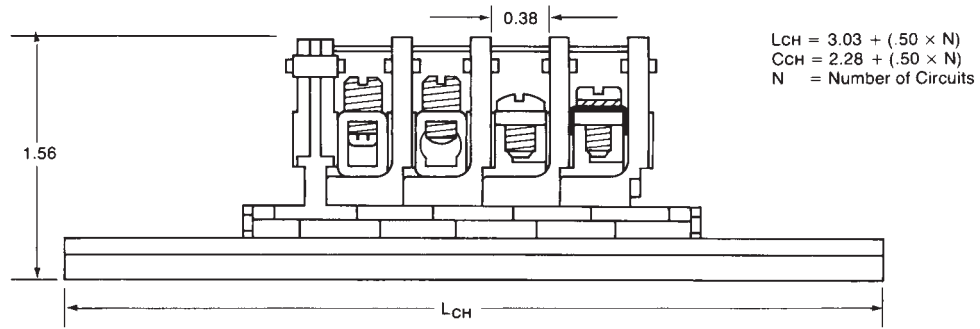
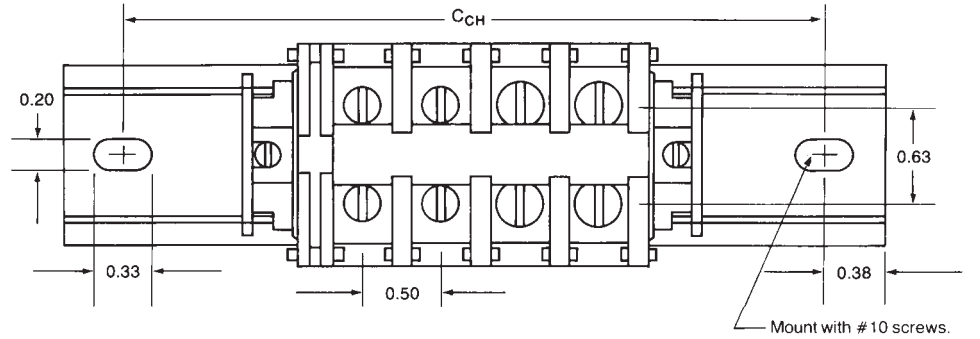



## 200 Series, Heavy Duty Phenolic Blocks

### Product Facts

- n **Sturdy Heavy Duty block accepts single or combinations of wire up to #4 AWG solid or stranded — at least 122 circuits per 6-foot length, 9/16" center-to-center spacing.**
- n **Choose from four different contact styles conservatively rated up to 90 amperes.**
- n **600 volt UL and NEMA rating.**
- n **Surface mounted flat base and channel mounted dovetail base models available.**
- n **Only one end section needed per block assembly.**
- n **Interlocking sectional fanning strips allow entire circuit groups to be connected and disconnected as a single unit.**
- n **Readily identify circuits — available with painted marking surface or use removable marking strip. Pre-printed strips are also available.**
- n **Factory assembled blocks available.**
- n **Heavy Duty Phenolic Block Sections Snap-fit with 300 & 600 volt, medium duty phenolic, heavy duty nylon and polypropylene, and Fuse and Switch blocks.**

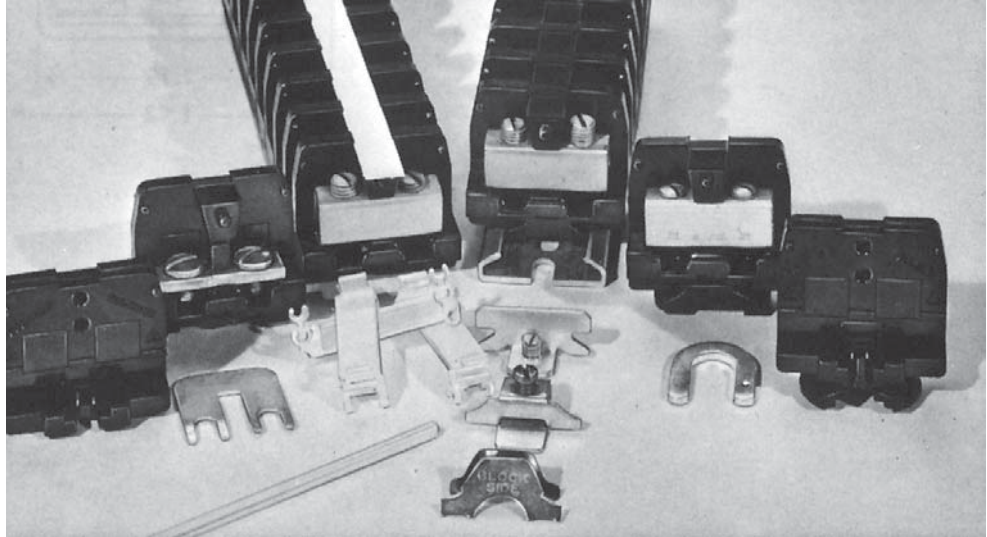

This family of phenolic heavy duty blocks is ideal for high temperature, high current applications. The rugged material withstands temperatures up to 302°F [150°C].

**Note:** All part numbers are RoHS Compliant.

**200 Series, Heavy Duty Phenolic, 600 V, 0.56" [14.24] Pitch**

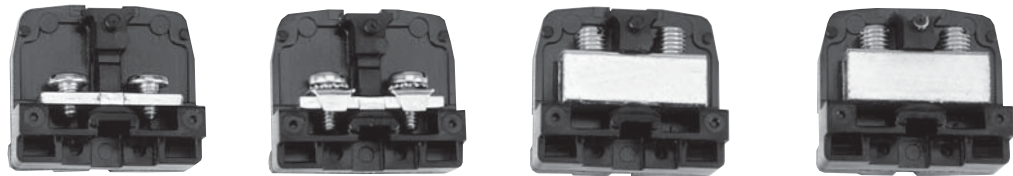

**Characteristics**                      **Strap Screw**                      **Strap Clamp**                      **Tubular Screw**                      **Tubular Clamp**

Type of Block	Model	Part Number	Model	Part Number	Model	Part Number	Model	Part Number
<b>Direct Mount (Flat Base)</b>								
Painted	221	3-1437390-1	228-BU	1-1437381-5	222-BU	3-1437390-3	223-BU	3-1437390-6
Unpainted	211	2-1437390-7	218	3-1437390-0	212	2-1437390-8	213	2-1437390-9
<b>Channel Mount (Dovetail Base)</b>								
Painted	0221	1437390-8	0228	1-1437390-3	0222	1437390-9	0223	1-1437390-2
Unpainted	0211	1437390-1	0218	1437390-7	0212	1437390-3	0213	1437390-5
<b>Contact Type</b>								



**Specifications**

Wire Range (AWG) Solid & Stranded	22-10	18-8	18-4	18-6
Wire Strip Length (in.)	—	1/2	1/2	1/2
Screw Type	10-32 binding head	8-32 pan head w/clamp	1/4-28 set screw	1/4-28 set screw
Ampacity	35 A	50 A	85 A	65 A
<b>End Sections</b>				
Direct Mount	230-BU 1-1437381-7	230-BU 1-1437381-7	230-BU 1-1437381-7	230-BU 1-1437381-7
Channel Mount	0230 1-1437390-4	0230 1-1437390-4	0230 1-1437390-4	0230 1-1437390-4

**Notes:**

For factory assembled blocks, suffix Catalog Number with number of blocks desired. See page 272 for dimensions and other details. (Maximum number of flat base preassembled sections is 12).

Example: Twenty dovetail based, tubular clamp blocks, preassembled on channel = 021320 (plain marking area)

Example: Twelve preassembled flat base, strap screw blocks = 22112 (painted marking area)

For factory assembled blocks supplied with a removable marking strip add — 1 to Catalog Number.

For blocks with two or more different contact sections, imprinted marking strips, or special features, consult Technical Support.

Environmental contacts for highly corrosive atmospheres are available with nickel plating on non-ferrous hardware. To order, prefix Catalog # with "D".

**Comparison (Type of Block)**

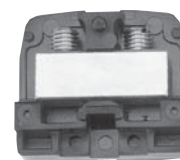

**Direct Mount (Flat Base)**

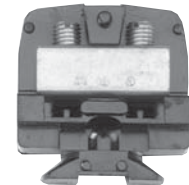

**Channel Mount (Dovetail Base)**



LR25557 E63810

**200 Series, Heavy Duty Phenolic, 600 V, 0.56" [14.24] Pitch** (Continued)



**Corrosion Resistant Strap Screw**

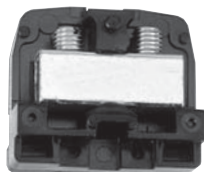

**Corrosion Resistant Tubular Screw**



**Corrosion Resistant Tubular Clamp**

Model	Part Number	Model	Part Number	Model	Part Number
D221	3-1437389-6	D222	3-1437389-8	D223	3-1437389-9
D211	3-1437389-4	D212	3-1437389-5	D213	4-1437390-6
D0221	1437389-7	D0222	1437389-8	D0223	1437389-9
D0211	1437389-2	D0212	1437389-4	D0213	1437389-6

**Contact Type**



**Specifications**

22-10	18-4	22-10
—	1/2	1/2
10-32 Nickel plated binding head	1/4-28 Nickel plated set screw	1/4-28 Nickel plated set screw
35 A	85 A	65 A
230-BU 1-1437381-7	230-BU 1-1437381-7	230-BU 1-1437381-7
0230 1-1437390-4	0230 1-1437390-4	0230 1-1437390-4

**Sectional Fanning Strips**

Description	Part No.	Catalog No.
Tubular Screw	1-1437381-8	24
Strap Screw	1-1437381-9	27
Molding Only, no contact	1447889-1	2400

**Note:**

For factory assembled fanning strips, suffix Catalog Number with number desired.

Example: Ten factory assembled sections of #24 = 2410

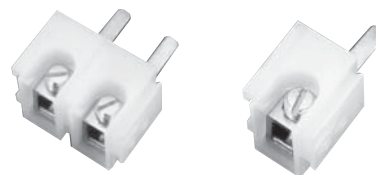

**Note:** All part numbers are RoHS Compliant.

## 200 Series, Heavy Duty Phenolic Accessories

### Mounting Channel

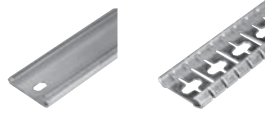

### Channel Clamps



Steel Channel	Break Away Steel	Pre-punched Aluminum Channel	Screw Channel Clamps	Universal Clamps	Snap-In Clamps	See-thru Cover	Ganging Rod
<b>Part Number</b>							
9-1437381-1 9-1437381-8	9-1437381-2	9-1437381-9 1437382-2	9-1437381-5	1437382-3	9-1437381-7	1-1437382-2	3-1437381-9
<b>Catalog Number</b>							
60 63-BU	60-B-36	64 67	61	68	62	23-BU	30-BU
<b>Standard Length</b>							
6 feet 3 feet	3 feet	6 feet 3 feet	—	—	—	—	2 feet

### Marking Accessories



### Jumpers



Plastic Cloth Tape	Plastic Cloth Tape	Vinyl Marking Strips	Elevated Marking Strip	Nylon Holding Plug	Jumper for Tubular Contacts	Jumper for Strap Screw
<b>Part Number</b>						
8-1437381-1	8-1437381-0	6-1437381-3	4-1437391-1	4-1437393-0	2-1437393-3	5-1437381-5
<b>Catalog Number</b>						
56	55-BU	50-BU	52-BU	65-BU	41-BU	43
<b>Standard Length</b>						
10 sheets	50 feet	25 feet	18 inches	—	—	—

### Related Product Data

**Wire Pins and Ferrules**—Pages 109-111  
 For more information on AMP Standard Terminals and Splices or Quick-Connect FASTON Receptacles and Tabs, request Catalog 82042.

## 200 Series, Heavy Duty Phenolic Specifications

### Material & Finish

#### Standard Contacts

**Material:** Electrical grade copper or copper alloy conductor. Steel Screws plated to resist corrosion in most industrial applications.

#### Environmental Contacts (for highly corrosive atmospheres)

**Tubular Screw:** - Electrical grade copper tube with nickel plating.

Nickel plated brass screws.

**Strap Screw:** - Nickel plated brass straps and screws

Nickel plating exceeds specification QQ-N-290 Class I, Type VII.

**Wire Range:** Strap Screw: #22-10 AWG max., solid or stranded with crimp terminals

**Strap Clamp:** #18-8 AWG, solid or stranded

**Tubular Screw:** #18-4 AWG, solid or stranded

**Tubular Clamp:** #18-6 AWG, solid or stranded

**Wire Strip Length:** Strap Screw: As needed for lugging

**Strap Clamp:** 1/2 in. [12.7]

**Tubular Screw:** 1/2 in. [12.7]

**Tubular Clamp:** 1/2 in. [12.7]

**Screw Type:** Strap Screw: 10-32 slotted binding head

**Strap Clamp:** 8-32 pan head w/ clamp

**Tubular Screw:** 1/4-28 slotted headless

**Tubular Clamp:** 1/4-28 slotted headless

**Strap Screw:** Maximum width of lugs: 11/32 in. [8.73]

### Independent Testing Service Listing and Recognition

WIRE SIZES, Solid or Stranded Tubular Screw

Tubular Screw

1 #4 AWG, 1 #6 AWG,

1 or 2 #8 AWG, 1 to 4 #10 AWG,

1 or 5 #12 AWG, 1 to 6 #14 AWG,

1 or 6 #16 AWG, 1 to 8 #18 AWG,

Tubular Clamp

1 #6 AWG, 1 or 2 #8 AWG,

1 to 3 #10 AWG, 1 to 4 #12 AWG,

1 or 4 #14 AWG, 1 to 6 #16 AWG,

1 or 8 #18 AWG

Strap Clamp

1 #18 to 1 #8 AWG

### Nylon Housing

**Material**—Phenolic, Filled Flame Retardant

**Max. Continuous Temperature**—150°C, [302°F]

**Breakdown Voltage**—

Contact-to-Contact: 7800V

Contact-to-Ground: 9400V

**Dielectric Strength (RH 40% at Sea Level)**—300 Volts/mil thickness per ASTM #D149

**UL High Voltage Arc Tracking (Inches/min.)**—.49-.58 [12.45-14.73]

**Water Absorption (24 hrs. % wt. gain)**—0.45% per ASTM D570

**Flammability**—UL94V-1

**Chemical Resistance**—Resistant to acids, alkalis, and aliphatic hydrocarbons and ketones, per ASTM D543.

**Radiation Resistance (ergs g-1 (C))**—2.7 x 108 min.

**Color**—Black

**Note:** All part numbers are RoHS Compliant.

**200 Series, Heavy Duty Phenolic**

**Flat Base**

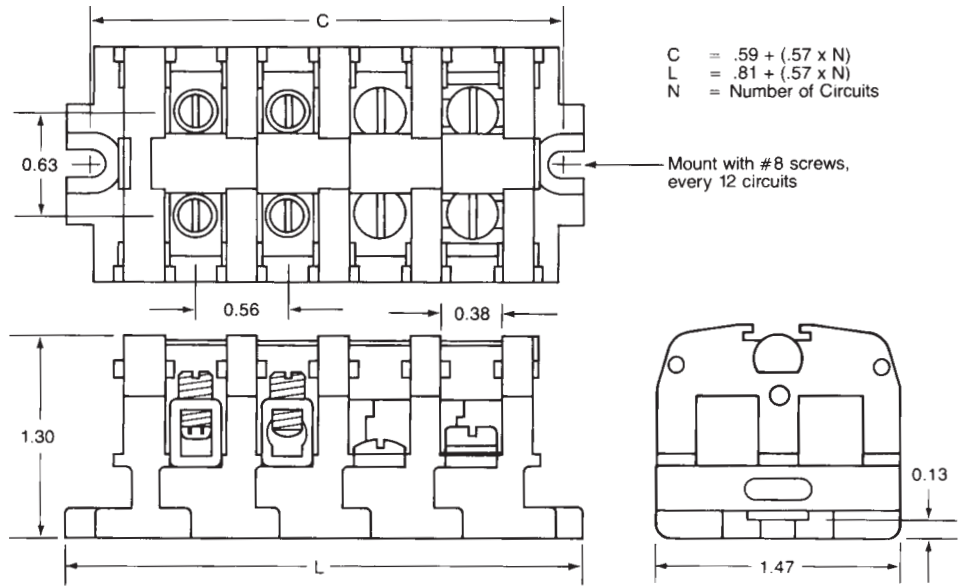

**Dovetail Base Mounted On Standard #60 Channel**

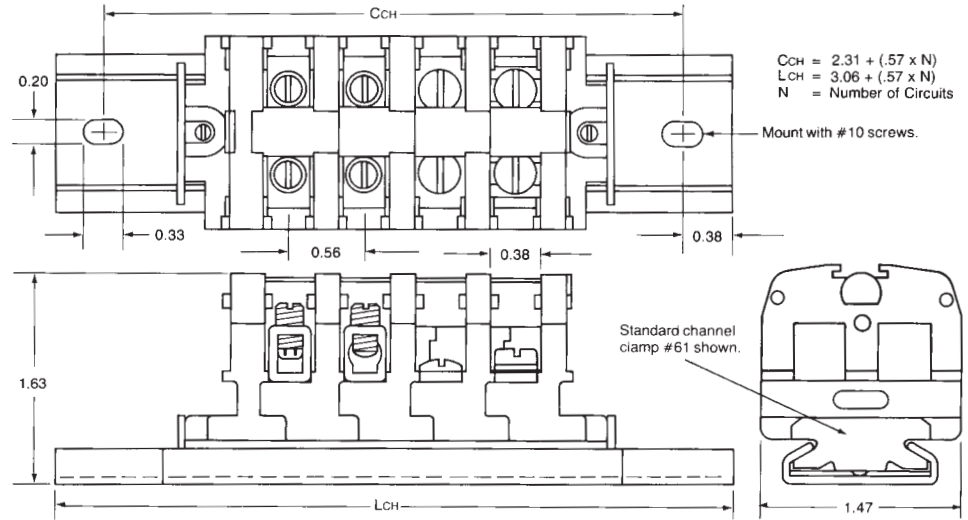

**Sectional Fanning Strips**

