

Customer Information Sheet

DRAWING No.: M80-502XXXX

SHEET 2 OF 2

IF IN DOUBT - ASK

©

NOT TO SCALE

THIRD ANGLE PROJECTION

ALL DIMENSIONS IN mm

SPECIFICATIONS:

MATERIAL:
 MOULDING = GLASS-FILLED PPS,
 UL94V-0, BLACK
 CONTACT = PHOSPHOR BRONZE
 JACKSCREW = STAINLESS STEEL
FINISH (CONTACTS):
 05 = 0.75µ ALL OVER GOLD
 22 = 0.75µ GOLD ON CONTACT AREA,
 3µ 90/10 TIN/LEAD ON TAILS
 42 = 0.75µ GOLD ON CONTACT AREA,
 3µ 100% TIN ON TAILS

ELECTRICAL:
 CURRENT RATING AT 25°C = 3.0A MAX
 CURRENT RATING AT 85°C = 2.2A MAX
 WORKING VOLTAGE = 120V AC/DC
 VOLTAGE PROOF = 360V AC/DC
 CONTACT RESISTANCE = 25 mΩ MAX
 INSULATION RESISTANCE = 100 MΩ MIN

MECHANICAL:
 DURABILITY = 500 OPERATIONS
ENVIRONMENTAL:
 TEMPERATURE RANGE = -55°C TO +125°C

PACKING: TUBE
 FOR COMPLETE SPECIFICATION, SEE COMPONENT SPECIFICATION C005XX (LATEST ISSUE)

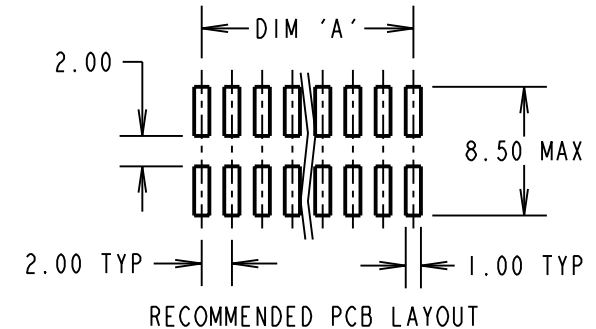
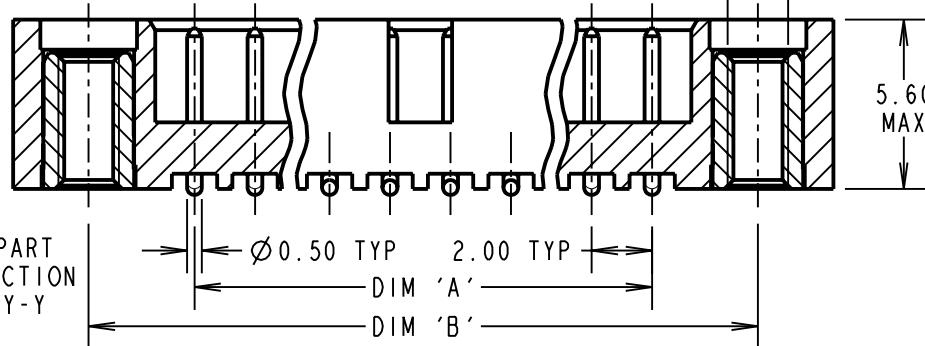
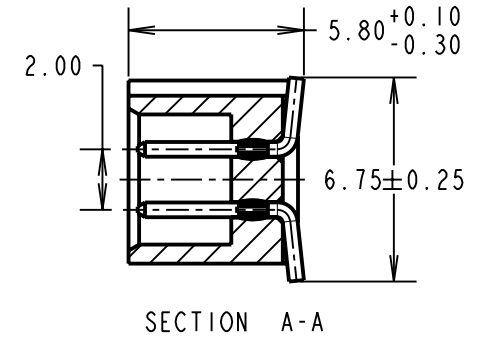
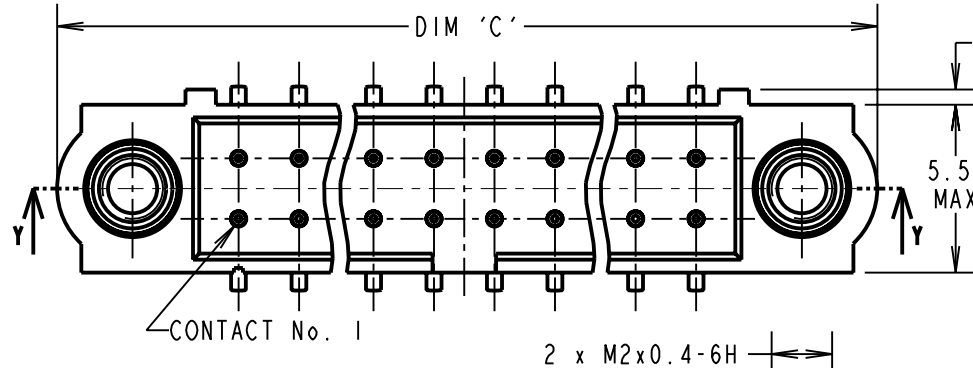

DIMENSION	CALCULATION
DIM 'A'	TOTAL No. OF CONTACTS - 2
DIM 'B'	TOTAL No. OF CONTACTS + 5
DIM 'C'	TOTAL No. OF CONTACTS + 10

EXAMPLE: CONNECTOR WITH 20 CONTACTS, GOLD CLIP AND 100% TIN SHELL, M80-5022042

DIM 'A' = 18.00mm, DIM 'B' = 25.00mm, DIM 'C' = 30.00mm

ORDER CODE:

M80-502XXXX

TOTAL No. OF CONTACTS
 04 TO 50
 (EVEN NUMBERS ONLY)

FINISH CODE

05 - ALL OVER GOLD
 22 - SELECTIVE GOLD + TIN/LEAD
 42 - SELECTIVE GOLD + 100% TIN

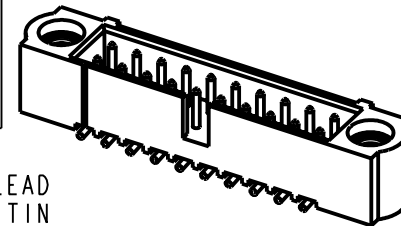

CP	4	19.05.10	8839
NAME	ISS.	DATE	C/NOTE
APPROVED: C.PENROSE			
CHECKED: R.ADDE			
DRAWN: B. M. KENT			
CUSTOMER REF.:			
ASSEMBLY DRG:			

HARWIN

HARWIN USA TEL: 603 893 5376 FAX: 603 893 5396 mis@harwin.com	HARWIN Europe (UK) TEL: 023 9231 4545 FAX: 023 9231 4590 mis@harwin.co.uk	HARWIN Asia TEL: +65 6 779 4909 FAX: +65 6 779 3868 mis@harwin.com.sg
--	--	--

THIS DRAWING AND ANY INFORMATION OR DESCRIPTIVE MATTER SET OUT HEREON ARE CONFIDENTIAL AND COPYRIGHT PROPERTY OF THE HARWIN GROUP AND MUST NOT BE DISCLOSED, LOANED, COPIED OR USED FOR MANUFACTURING, TENDERING OR FOR ANY OTHER PURPOSE WITHOUT THEIR WRITTEN PERMISSION.

TOLERANCES
 X. = ±1mm
 X.X = ±0.25mm
 X.XX = ±0.10mm
 X.XXX = ±0.01mm
ANGLES = ±5°
 UNLESS STATED

MATERIAL:
 SEE ABOVE
FINISH: SEE ABOVE
S/AREA: mm²

TITLE: JACKSCREW DATAMATE
 DIL VERTICAL SMT
 MALE ASSEMBLY

DRAWING NUMBER:
M80-502XXXX

SHT
 2
 OF 2