



4 Pad Plastic Package, 1.4 mm x 7 mm



IL3R Series

Product Features:

- Low Cost SMD Package
- Low ESR
- Compatible with Leadfree Processing

Applications:

- Fibre Channel
- Server & Storage
- Sonet /SDH
- 802.11 / Wifi
- T1/E1, T3/E3

Frequency	32.768 kHz
ESR (Equivalent Series Resistance)	65 kΩ Max.
Shunt Capacitance (C0)	1.2 pF Typical
Frequency Tolerance @ 25° C	±20 ppm Standard
Frequency Stability over Temperature	Parabolic -0.034 ppm / ° C ² Typical. Inflection point approx. 27° C. See graph below.
Crystal Cut	X Cut
Load Capacitance	12.5 pF Standard
Drive Level	1 uW Max.
Aging	±5 ppm Max. / Year Standard
Temperature	
Operating	-40° C to +85° C Standard
Storage	-40° C to +85° C Standard

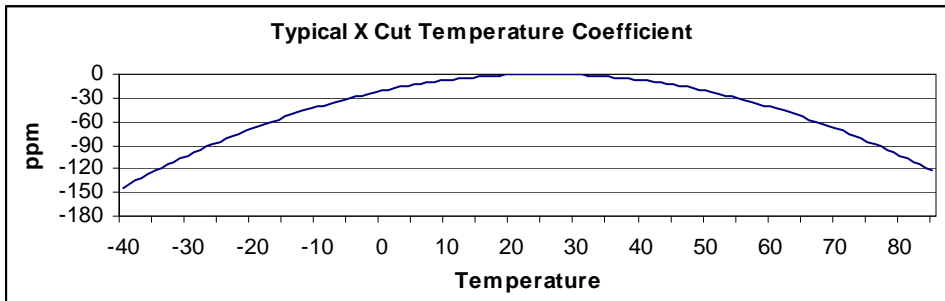
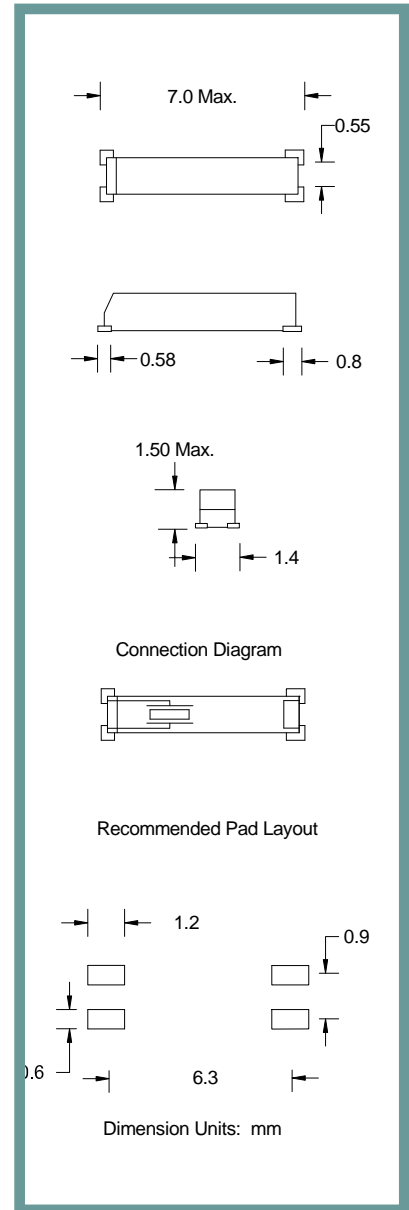

Part Number Guide		Sample Part Number: IL3R - HX5F12.5 - 32.768 kHz				
Package	Tolerance (ppm) at Room Temperature	Stability (ppm) over Operating Temperature	Operating Temperature Range	Mode (overtone)	Load Capacitance (pF)	Frequency
IL3R -	H = ±20 ppm	X = X Cut	5 = -40°C to +85°C	F = Fundamental	12.5 pF Standard. 6 pF Available	- 32.768 kHz



4 Pad Plastic Package, 1.4 mm x 7 mm



IL3R Series

Pb Free Solder Reflow Profile:

Typical Circuit:

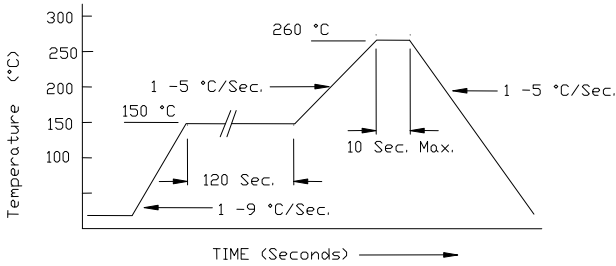

*Units are backward compatible with 240C reflow processes

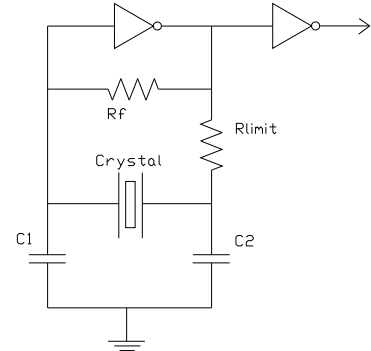

Package Information:

MSL = 2a
Termination = e1 (Sn/Cu/Ag over Ni over Kovar base metal)

Tape and Reel Information:

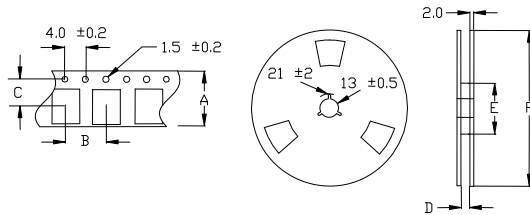

Quantity per Reel	3000
A	16 +/- .3
B	8 +/- .2
C	7.5 +/- .2
D	17.5 +/- 1.5
E	50 / 60 / 80
F	180 / 250

Environmental Specifications

Thermal Shock	MIL-STD-883, Method 1011, Condition A
Moisture Resistance	MIL-STD-883, Method 1004
Mechanical Shock	MIL-STD-883, Method 2002, Condition B
Mechanical Vibration	MIL-STD-883, Method 2007, Condition A
Resistance to Soldering Heat	J-STD-020C, Table 5-2 Pb-free devices (except 2 cycles max)
Hazardous Substance	Pb-Free / RoHS / Green Compliant
Solderability	JESD22-B102-D Method 2 (Preconditioning E)
Terminal Strength	MIL-STD-883, Method 2004, Test Condition D
Gross Leak	MIL-STD-883, Method 1014, Condition C
Fine Leak	MIL-STD-883, Method 1014, Condition A2, R1=2x10 ⁻⁸ atm cc/s
Solvent Resistance	MIL-STD-202, Method 215

Marking

Line 1: Date Code(yww), Factory Code