

euro-block

product specification

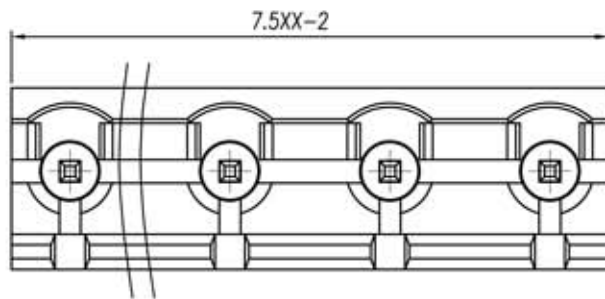

Electrical		
Standard	UL	IEC
Rated voltage	300V	320V
Rated current	15A	20A
Contact resistance	20mΩ	
Insulation resistance	500MΩ/DC500V	
Withstanding voltage	AC2000V/1 Min	
Mechanical		
Temp. Range	-40°C + 105°C	
Max soldering temp.	+250°C for 5 sec	
Dimensions		
Pitch	7.5 mm	
Poles	2+24	
Material		
Housing	PA66, UL94V0	
Pin header	Brass, tin plated	

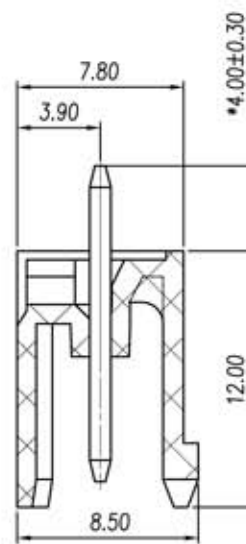
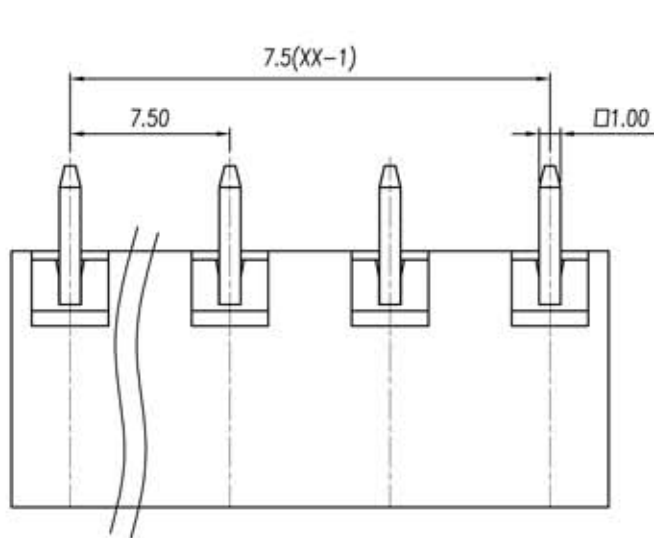
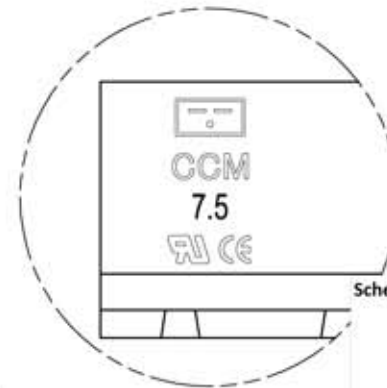

Schema generale del codice di ordinazione/General description of ordering code

Series	n. poles	pitch	version	color	custom
CCM	02+24	7.5	V		

linear dimension (Tolerances Standard GB/T 14486-2008)											≡	-	□	//	⊥	
variable range	to 6	over 6 to 10	over 10 to 18	over 18 to 30	over 30 to 50	over 50 to 80	over 80 to 120	over 120 to 160	over 160 to 200	over 200 to 250	all	to 5	over 5 to 30	over 30 to 120	over 120 to	
tolerance	±0.1	±0.14	±0.19	±0.25	±0.32	±0.43	±0.57	±0.72	±0.88	±1.05	±1.25	0.5	0.025	0.06	0.12	0.4

UNITS	mm	SIZE	A4	SCALE	3:1	THIRD ANGLE PROJECTION
euro-block						 CCM-7.5-V