

High Speed/High Temperature Digital Isolators

Functional Diagram

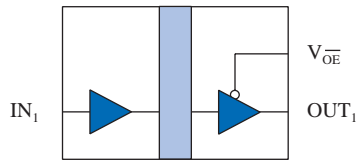

IL710

Truth Table

V _I	V _{OE}	V _O
L	L	L
H	L	H
L	H	Z
H	H	Z

Features

- +5 V/+3.3 V CMOS / TTL Compatible
- High Speed: 150 Mbps Typical (IL710S)
- High Temperature: -40°C to +125°C (IL710T)
- 2500 V_{RMS} Isolation (1 min.)
- 300 ps Typical Pulse Width Distortion (IL710S)
- 100 ps Typical Pulse Jitter
- 4 ns Typical Propagation Delay Skew
- 10 ns Typical Propagation Delay
- 30 kV/μs Typical Common Mode Transient Immunity
- Low EMC Footprint
- 8-pin MSOP, SOIC, and PDIP Packages
- UL1577 and IEC 61010-2001 Approved

Applications

- Digital Fieldbus
- RS-485 and RS-422
- Multiplexed Data Transmission
- Data Interfaces
- Board-to-Board Communication
- Digital Noise Reduction
- Operator Interface
- Ground Loop Elimination
- Peripheral Interfaces
- Serial Communication
- Logic Level Shifting

Description

NVE's IL700 family of high-speed digital isolators are CMOS devices manufactured with NVE's patented* IsoLoop[®] spintronic Giant Magnetoresistive (GMR) technology. The IL710S is the world's fastest isolator of its type, with a 150 Mbps typical data rate.

The symmetric magnetic coupling barrier provides a typical propagation delay of only 10 ns and a pulse width distortion as low as 300 ps (0.3 ns), achieving the best specifications of any isolator. Typical transient immunity of 30 kV/μs is unsurpassed. The IL710 is ideal for isolating applications such as PROFIBUS, RS-485, and RS-422.

The IL710 is available in 8-pin MSOP, SOIC, and PDIP packages. Standard and S-Grade parts are specified over a temperature range of -40°C to +100°C; T-Grade parts are specified over a temperature range of -40°C to +125°C.

Absolute Maximum Ratings

Parameters	Symbol	Min.	Typ.	Max.	Units	Test Conditions
Storage Temperature	T_s	-55		150	°C	
Ambient Operating Temperature ⁽¹⁾ IL710T	T_A	-55		125 135	°C	
Supply Voltage	V_{DD1}, V_{DD2}	-0.5		7	V	
Input Voltage	V_I	-0.5		$V_{DD1}+0.5$	V	
Input Voltage	V_{OE}	-0.5		$V_{DD2}+0.5$	V	
Output Voltage	V_O	-0.5		$V_{DD2}+0.5$	V	
Output Current Drive	I_O			10	mA	
Lead Solder Temperature				260	°C	10 sec.
ESD			2		kV	HBM

Recommended Operating Conditions

Parameters	Symbol	Min.	Typ.	Max.	Units	Test Conditions
Ambient Operating Temperature IL710 and IL710S	T_A	-40		100	°C	
IL710T	T_A	-40		125	°C	
Supply Voltage	V_{DD1}, V_{DD2}	3.0		5.5	V	
Logic High Input Voltage	V_{IH}	2.4		V_{DD1}	V	
Logic Low Input Voltage	V_{IL}	0		0.8	V	
Input Signal Rise and Fall Times	t_{IR}, t_{IF}			1	µs	

Insulation Specifications

Parameters	Symbol	Min.	Typ.	Max.	Units	Test Conditions
Creepage Distance						
MSOP		3.01			mm	
SOIC		4.04			mm	
PDIP		7.04			mm	
Leakage Current ⁽⁵⁾			0.2		µA	240 V _{RMS} , 60 Hz
Barrier Impedance ⁽⁵⁾			$>10^{14} \parallel 3$		$\Omega \parallel pF$	

Package Characteristics

Parameters	Symbol	Min.	Typ.	Max.	Units	Test Conditions
Capacitance (Input-Output) ⁽⁵⁾	C_{I-O}		1.1		pF	f = 1 MHz
Thermal Resistance						
MSOP	θ_{JC}		168		°C/W	Thermocouple at center underside of package
SOIC	θ_{JC}		144		°C/W	
PDIP	θ_{JC}		54		°C/W	
Package Power Dissipation	P_{PD}			150	mW	f = 1 MHz, $V_{DD} = 5 V$

Safety and Approvals

IEC61010-1

TUV Certificate Numbers:

N1502812, N1502812-101

Classification as Reinforced Insulation

Model	Package	Pollution Degree	Material Group	Max. Working Voltage
IL710-1	MSOP	II	III	150 V _{RMS}
IL710-2	PDIP	II	III	300 V _{RMS}
IL710-3	SOIC	II	III	150 V _{RMS}

UL 1577

Component Recognition Program File Number: E207481

Rated 2500V_{RMS} for 1 minute

Soldering Profile

Per JEDEC J-STD-020C, MSL=2

IL710 Pin Connections

1	V_{DD1}	Supply voltage
2	IN	Data In
3	NC	No internal connection
4	GND_1	Ground return for V_{DD1}
5	GND_2	Ground return for V_{DD2}
6	OUT	Data Out
7	V_{OE}	Output enable. Internally held low with 100 k Ω
8	V_{DD2}	Supply voltage

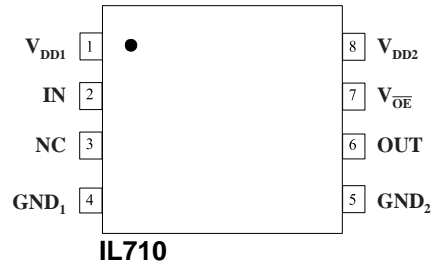

Timing Diagram

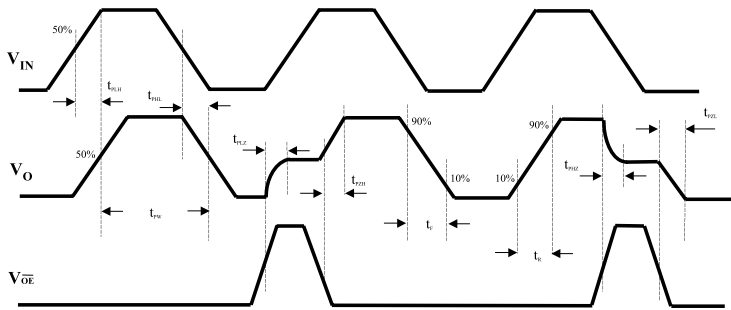

Legend

t_{PLH}	Propagation Delay, Low to High
t_{PHL}	Propagation Delay, High to Low
t_{PW}	Minimum Pulse Width
t_{PLZ}	Propagation Delay, Low to High Impedance
t_{PZH}	Propagation Delay, High Impedance to High
t_{PHZ}	Propagation Delay, High to High Impedance
t_{PZL}	Propagation Delay, High Impedance to Low
t_R	Rise Time
t_F	Fall Time

3.3 Volt Electrical Specifications

Electrical specifications are T_{min} to T_{max} unless otherwise stated.

Parameters	Symbol	Min.	Typ.	Max.	Units	Test Conditions
DC Specifications						
Input Quiescent Supply Current	I_{DD1}		8	10	μA	
Output Quiescent Supply Current IL710 and IL710S IL710T	I_{DD2}		1.7 3.3	2 4	mA	
Logic Input Current	I_I	-10		10	μA	
Logic High Output Voltage	V_{OH}	$V_{DD}-0.1$	V_{DD}		V	$I_O = -20 \mu\text{A}, V_I = V_{IH}$
		$0.8 \times V_{DD}$	$0.9 \times V_{DD}$			$I_O = -4 \text{ mA}, V_I = V_{IH}$
Logic Low Output Voltage	V_{OL}		0	0.1	V	$I_O = 20 \mu\text{A}, V_I = V_{IL}$
			0.5	0.8		$I_O = 4 \text{ mA}, V_I = V_{IL}$
Switching Specifications						
Maximum Data Rate IL710 and IL710T IL710S		100 130	110 140		Mbps Mbps	$C_L = 15 \text{ pF}$ $C_L = 15 \text{ pF}$
Pulse Width ⁽⁷⁾	PW	10	7.5		ns	50% Points, V_O
Propagation Delay Input to Output (High to Low)	t_{PHL}		12	18	ns	$C_L = 15 \text{ pF}$
Propagation Delay Input to Output (Low to High)	t_{PLH}		12	18	ns	$C_L = 15 \text{ pF}$
Propagation Delay Enable to Output (High to High Impedance)	t_{PHZ}		3	5	ns	$C_L = 15 \text{ pF}$
Propagation Delay Enable to Output (Low to High Impedance)	t_{PLZ}		3	5	ns	$C_L = 15 \text{ pF}$
Propagation Delay Enable to Output (High Impedance to High)	t_{PZH}		3	5	ns	$C_L = 15 \text{ pF}$
Propagation Delay Enable to Output (High Impedance to Low)	t_{PZL}		3	5	ns	$C_L = 15 \text{ pF}$
Pulse Width Distortion ⁽²⁾ IL710 and IL710T IL710S	PWD		2	3	ns	$C_L = 15 \text{ pF}$
			1	3		
Pulse Jitter ⁽⁸⁾	t_j			100	ps	$C_L = 15 \text{ pF}$
Propagation Delay Skew ⁽³⁾	t_{PSK}		4	6	ns	$C_L = 15 \text{ pF}$
Output Rise Time (10%–90%)	t_R		2	4	ns	$C_L = 15 \text{ pF}$
Output Fall Time (10%–90%)	t_F		2	4	ns	$C_L = 15 \text{ pF}$
Common Mode Transient Immunity (Output Logic High or Logic Low) ⁽⁴⁾	$ CM_H , CM_L $	20	30		kV/ μs	$V_{CM} = 300 \text{ V}$
Dynamic Power Consumption ⁽⁶⁾			140	240	$\mu\text{A}/\text{MHz}$	

5 Volt Electrical Specifications

Electrical specifications are T_{min} to T_{max} unless otherwise stated.

Parameters	Symbol	Min.	Typ.	Max.	Units	Test Conditions
DC Specifications						
Input Quiescent Supply Current	I_{DD1}		10	15	μA	
Output Quiescent Supply Current IL710 and IL710S IL710T	I_{DD2}		2.5 5	3 6	mA	
Logic Input Current	I_I	-10		10	μA	
Logic High Output Voltage	V_{OH}	$V_{DD}-0.1$	V_{DD}		V	$I_O = -20 \mu\text{A}, V_I = V_{IH}$
		$0.8 \times V_{DD}$	$0.9 \times V_{DD}$			$I_O = -4 \text{ mA}, V_I = V_{IH}$
Logic Low Output Voltage	V_{OL}		0	0.1	V	$I_O = 20 \mu\text{A}, V_I = V_{IL}$
			0.5	0.8		$I_O = 4 \text{ mA}, V_I = V_{IL}$
Switching Specifications						
Maximum Data Rate IL710 and IL710T IL710S		100 130	110 150		Mbps Mbps	$C_L = 15 \text{ pF}$ $C_L = 15 \text{ pF}$
Pulse Width ⁽⁷⁾	PW	10	7.5		ns	50% Points, V_o
Propagation Delay Input to Output (High to Low)	t_{PHL}		10	15	ns	$C_L = 15 \text{ pF}$
Propagation Delay Input to Output (Low to High)	t_{PLH}		10	15	ns	$C_L = 15 \text{ pF}$
Propagation Delay Enable to Output (High to High Impedance)	t_{PHZ}		3	5	ns	$C_L = 15 \text{ pF}$
Propagation Delay Enable to Output (Low to High Impedance)	t_{PLZ}		3	5	ns	$C_L = 15 \text{ pF}$
Propagation Delay Enable to Output (High Impedance to High)	t_{PZH}		3	5	ns	$C_L = 15 \text{ pF}$
Propagation Delay Enable to Output (High Impedance to Low)	t_{PZL}		3	5	ns	$C_L = 15 \text{ pF}$
Pulse Width Distortion ⁽²⁾ IL710 and IL710T IL710S	PWD		2 0.3	3 3	ns	$C_L = 15 \text{ pF}$
Propagation Delay Skew ⁽³⁾	t_{PSK}		4	6	ns	$C_L = 15 \text{ pF}$
Output Rise Time (10%–90%)	t_R		1	3	ns	$C_L = 15 \text{ pF}$
Output Fall Time (10%–90%)	t_F		1	3	ns	$C_L = 15 \text{ pF}$
Common Mode Transient Immunity (Output Logic High or Logic Low) ⁽⁴⁾	$ CM_H , CM_L $	20	30		kV/ μs	$V_{cm} = 300 \text{ V}$
Dynamic Power Consumption ⁽⁶⁾			200	340	$\mu\text{A}/\text{MHz}$	

Notes (apply to both 3.3 V and 5 V specifications):

- Absolute maximum ambient operating temperature means the device will not be damaged if operated under these conditions. It does not guarantee performance.
- PWD is defined as $|t_{PHL} - t_{PLH}|$. %PWD is equal to PWD divided by pulse width.
- t_{PSK} is the magnitude of the worst-case difference in t_{PHL} and/or t_{PLH} between devices at 25°C.
- CM_H is the maximum common mode voltage slew rate that can be sustained while maintaining $V_o > 0.8 V_{DD2}$. CM_L is the maximum common mode input voltage that can be sustained while maintaining $V_o < 0.8 \text{ V}$. The common mode voltage slew rates apply to both rising and falling common mode voltage edges.
- Device is considered a two terminal device: pins 1–4 shorted and pins 5–8 shorted.
- Dynamic power consumption is calculated per channel and is supplied by the channel's input side power supply.
- Minimum pulse width is the minimum value at which specified PWD is guaranteed.
- 66,535-bit pseudo-random binary signal (PRBS) NRZ bit pattern with no more than five consecutive 1s or 0s; 800 ps transition time.

Application Information

Electrostatic Discharge Sensitivity

This product has been tested for electrostatic sensitivity to the limits stated in the specifications. However, NVE recommends that all integrated circuits be handled with appropriate care to avoid damage. Damage caused by inappropriate handling or storage could range from performance degradation to complete failure.

Electromagnetic Compatibility

IsoLoop Isolators have the lowest EMC footprint of any isolation technology. IsoLoop Isolators' Wheatstone bridge configuration and differential magnetic field signaling ensure excellent EMC performance against all relevant standards.

These isolators are fully compliant with generic EMC standards EN50081, EN50082-1 and the umbrella line-voltage standard for Information Technology Equipment (ITE) EN61000. NVE has completed compliance tests in the categories below:

EN50081-1

Residential, Commercial & Light Industrial
Methods EN55022, EN55014

EN50082-2: Industrial Environment

Methods EN61000-4-2 (ESD), EN61000-4-3 (Electromagnetic Field Immunity), EN61000-4-4 (Electrical Transient Immunity), EN61000-4-6 (RFI Immunity), EN61000-4-8 (Power Frequency Magnetic Field Immunity), EN61000-4-9 (Pulsed Magnetic Field), EN61000-4-10 (Damped Oscillatory Magnetic Field)

ENV50204

Radiated Field from Digital Telephones (Immunity Test)

Immunity to external magnetic fields is even higher if the field direction is "end-to-end" rather than to "pin-to-pin" as shown in the diagram below:

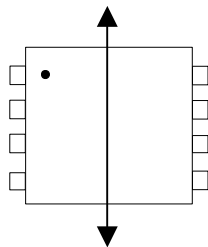

Cross-axis Field Direction

Dynamic Power Consumption

IsoLoop Isolators achieve their low power consumption from the way they transmit data across the isolation barrier. By detecting the edge transitions of the input logic signal and converting these to narrow current pulses, a magnetic field is created around the GMR Wheatstone bridge. Depending on the direction of the magnetic field, the bridge causes the output comparator to switch following the input logic signal. Since the current pulses are narrow, about 2.5 ns, the power consumption is independent of mark-to-space ratio and solely dependent on frequency. This has obvious advantages over optocouplers, which have power consumption heavily dependent on mark-to-space ratio.

Power Supply Decoupling

Both power supplies to these devices should be decoupled with low ESR 47 nF ceramic capacitors. Ground planes for both GND₁ and GND₂ are highly recommended for data rates above 10 Mbps. Capacitors must be located as close as possible to the V_{DD} pins.

Signal Status on Start-up and Shut Down

To minimize power dissipation, input signals are differentiated and then latched on the output side of the isolation barrier to reconstruct the signal. This could result in an ambiguous output state depending on power up, shutdown and power loss sequencing. Therefore, the designer should consider including an initialization signal in the start-up circuit. Initialization consists of toggling the input either high then low, or low then high.

Data Transmission Rates

The reliability of a transmission system is directly related to the accuracy and quality of the transmitted digital information. For a digital system, those parameters which determine the limits of the data transmission are pulse width distortion and propagation delay skew.

Propagation delay is the time taken for the signal to travel through the device. This is usually different when sending a low-to-high than when sending a high-to-low signal. This difference, or error, is called pulse width distortion (PWD) and is usually in nanoseconds. It may also be expressed as a percentage:

$$\text{PWD}\% = \frac{\text{Maximum Pulse Width Distortion (ns)}}{\text{Signal Pulse Width (ns)}} \times 100\%$$

For example, with data rates of 12.5 Mbps:

$$\text{PWD}\% = \frac{3 \text{ ns}}{80 \text{ ns}} \times 100\% = 3.75\%$$

This figure is almost **three times** better than any available optocoupler with the same temperature range, and **two times** better than any optocoupler regardless of published temperature range. IsoLoop isolators exceed the 10% maximum PWD recommended by PROFIBUS, and will run to nearly 35 Mb within the 10% limit.

Propagation delay skew is the signal propagation difference between two or more channels. This becomes significant in clocked systems because it is undesirable for the clock pulse to arrive before the data has settled. Short propagation delay skew is therefore especially critical in high data rate parallel systems for establishing and maintaining accuracy and repeatability. Worst-case channel-to-channel skew in an IL700 Isolator is only 3 ns, which is **ten times** better than any optocoupler. IL700 Isolators have a maximum propagation delay skew of 6 ns, which is **five times** better than any optocoupler.

Application Diagrams

Isolated PROFIBUS / RS-485

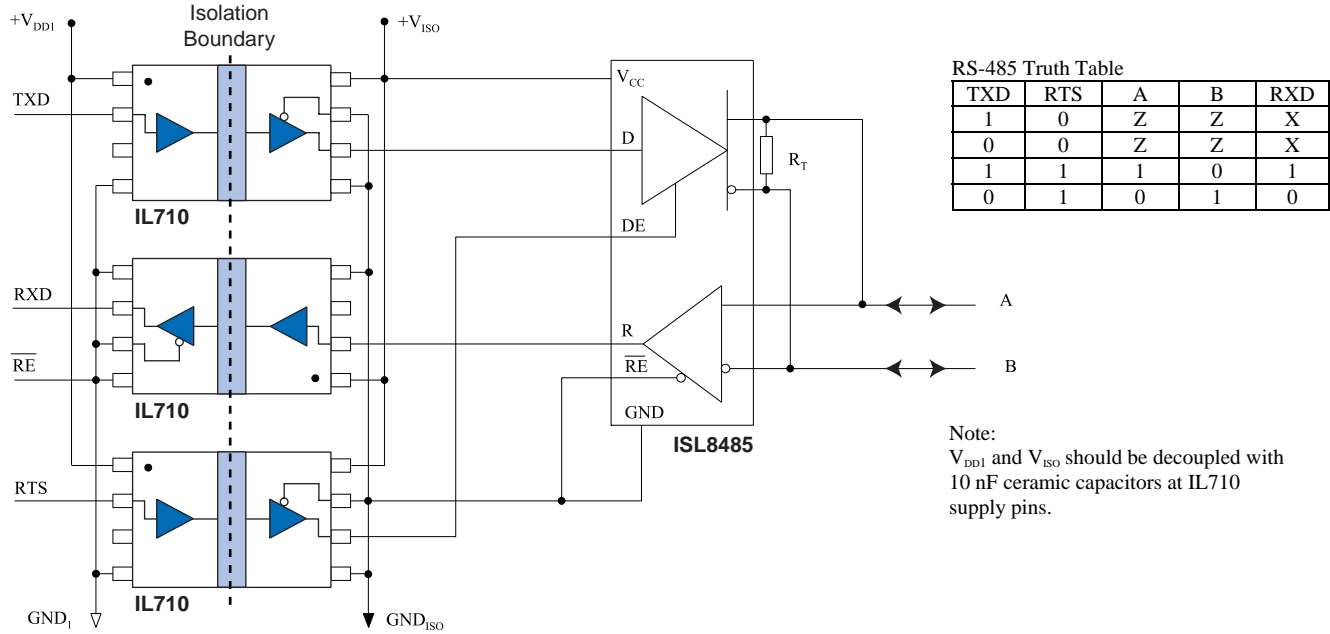

NVE offers a unique line of PROFIBUS/RS-485 transceivers, but IL710 isolators can also be used as part of multi-chip designs using non-isolated PROFIBUS transceivers.

Isolated USB

All power supplied by USB node's external supply on this side of isolation boundary

Power supplied by USB bus power this side of isolation boundary

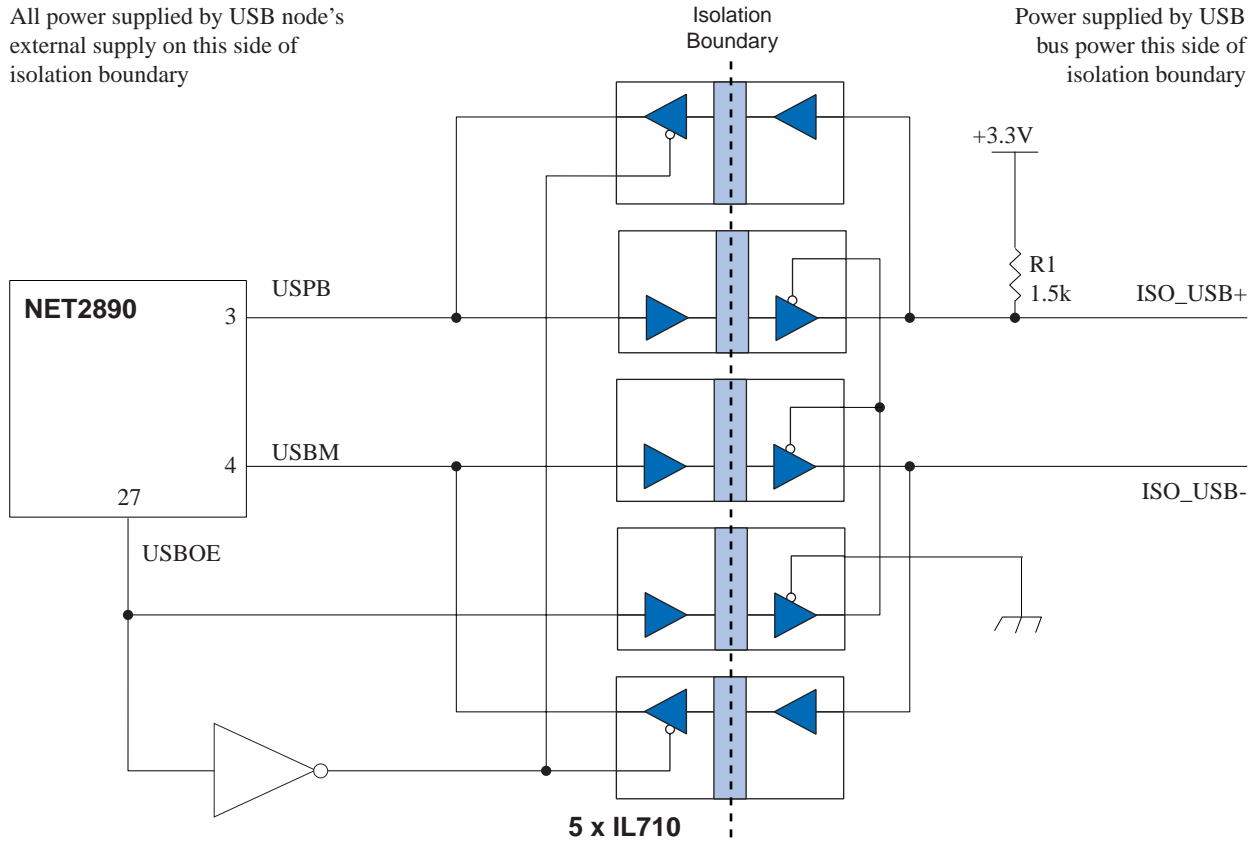

In this circuit, power is supplied by USB bus power on one side of the isolation barrier, and the USB node's external supply on the other side of the barrier. IL700 Isolators are specified with just 3 ns worst-case pulse width distortion.

Package Drawings, Dimensions and Specifications

8-pin MSOP

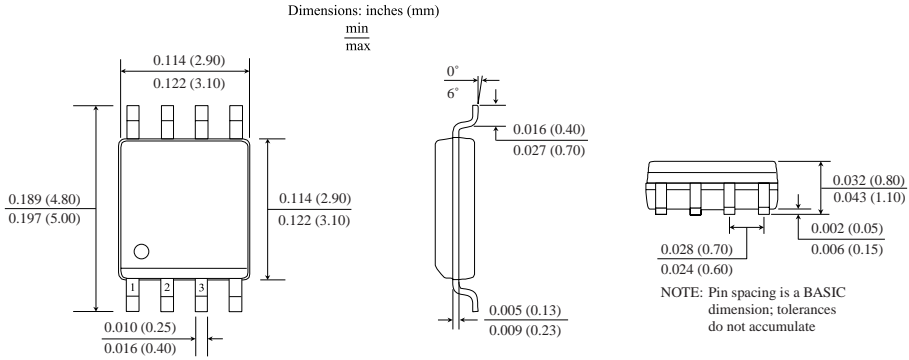

8-pin SOIC Package

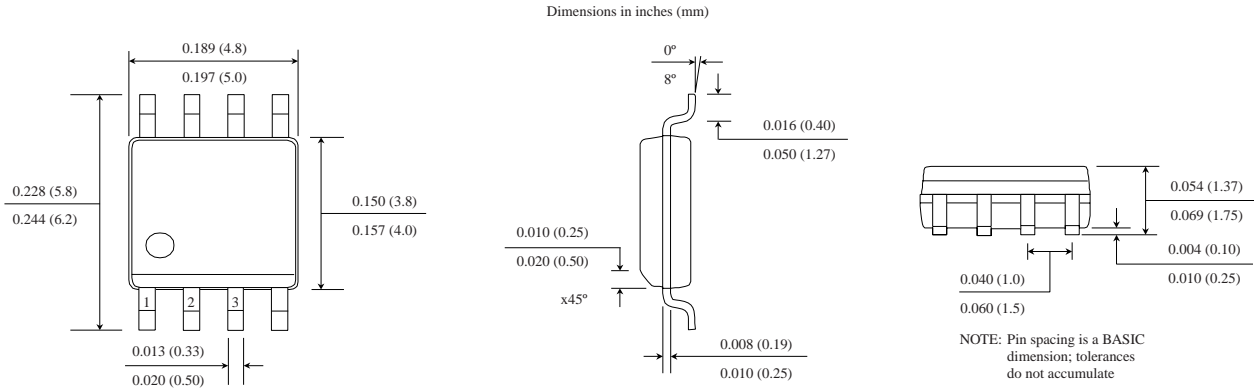

8-pin PDIP

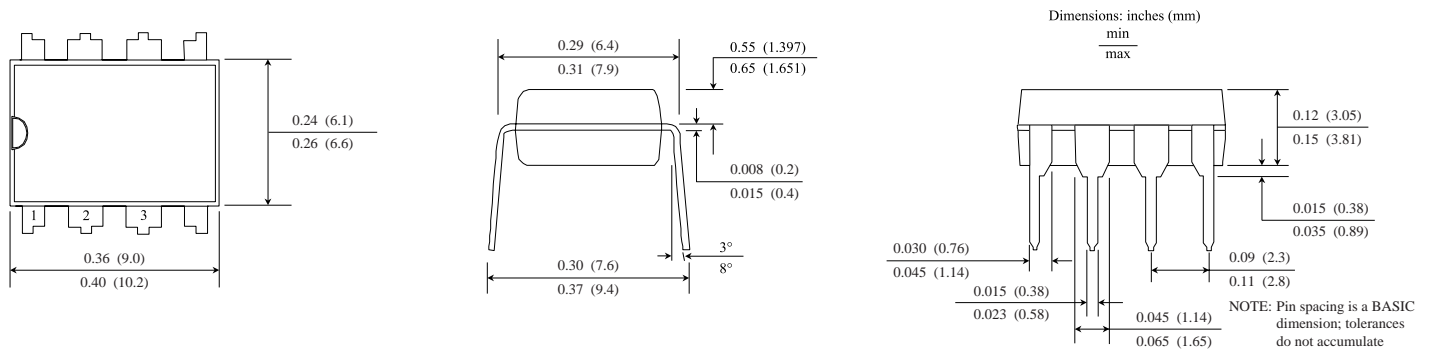

Ordering Information and Valid Part Numbers

IL 710 T - 3 E TR13

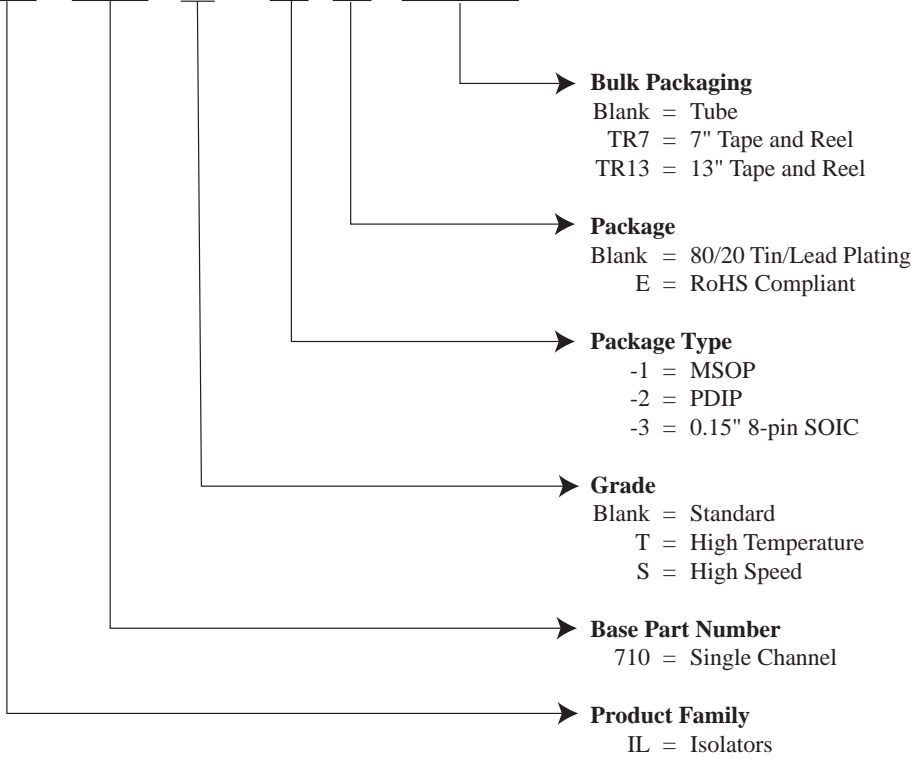

Valid Part Numbers

IL710-1E
IL710S-1E
IL710T-1E

IL710-2
IL710T-2
IL710-2E
IL710T-2E

IL710-3
IL710S-3
IL710T-3
IL710-3E
IL710S-3E
IL710T-3E

All MSOP and SOIC parts are available on tape and reel.



ISB-DS-001-IL710-V
September 2010

Changes

- Additional changes to MSOP pin spacing on package drawing.

ISB-DS-001-IL710-U

Changes

- Changed MSOP pin spacing on package drawing.

ISB-DS-001-IL710-T

Changes

- Added typical jitter specification at 5V.

ISB-DS-001-IL710-S

Changes

- Added EMC details.

ISB-DS-001-IL710-R

Changes

- IEC 61010 approval for MSOP version.

ISB-DS-001-IL710-Q

Changes

- Added magnetic immunity to 3.3 and 5 volt electrical specifications.
- Added diagram showing cross-axis direction.
- Added magnetic compatibility to the applications information section.

ISB-DS-001-IL710-P

Changes

- Note on all package drawings that pin-spacing tolerances are non-accumulating; change MSOP pin-spacing dimensions and tolerance accordingly.

ISB-DS-001-IL710-O

Changes

- Corrected PWD spec. on Isolated USB application diagram (p. 8).
- Changed lower limit of length on PDIP package drawing and tightened pin-spacing tolerance on MSOP package drawing (p. 9).

ISB-DS-001-IL710-N

Changes

- Changed IL710T output quiescent supply current specifications.

ISB-DS-001-IL710-M

Changes

- Changed ordering information to reflect that devices are now fully RoHS compliant with no exemptions.

ISB-DS-001-IL710-L

Changes

- Eliminated soldering profile chart

ISB-DS-001-IL710-K

Changes

- Edited Profibus application

ISB-DS-001-IL710-J

Changes

- MSOP package, S- and T-Grades added
- Order information updated

ISB-DS-001-IL710-I

Changes

- Added MSOP specifications
- Updated UL and IEC numbers

About NVE

An ISO 9001 Certified Company

NVE Corporation manufactures innovative products based on unique spintronic Giant Magnetoresistive (GMR) technology. Products include Magnetic Field Sensors, Magnetic Field Gradient Sensors (Gradiometers), Digital Magnetic Field Sensors, Digital Signal Isolators, and Isolated Bus Transceivers.

NVE pioneered spintronics and in 1994 introduced the world's first products using GMR material, a line of ultra-precise magnetic sensors for position, magnetic media, gear speed and current sensing.

NVE Corporation
11409 Valley View Road
Eden Prairie, MN 55344-3617 USA
Telephone: (952) 829-9217
Fax: (952) 829-9189
Internet: www.nve.com
e-mail: isoinfo@nve.com

The information provided by NVE Corporation is believed to be accurate. However, no responsibility is assumed by NVE Corporation for its use, nor for any infringement of patents, nor rights or licenses granted to third parties, which may result from its use. No license is granted by implication, or otherwise, under any patent or patent rights of NVE Corporation. NVE Corporation does not authorize, nor warrant, any NVE Corporation product for use in life support devices or systems or other critical applications, without the express written approval of the President of NVE Corporation.

Specifications are subject to change without notice.

ISB-DS-001-IL710-V
September 2010