



Intel[®] 31244 PCI-X to Serial ATA Controller

Developer's Manual

April 2004





INFORMATION IN THIS DOCUMENT IS PROVIDED IN CONNECTION WITH INTEL® PRODUCTS. EXCEPT AS PROVIDED IN INTEL'S TERMS AND CONDITIONS OF SALE FOR SUCH PRODUCTS, INTEL ASSUMES NO LIABILITY WHATSOEVER, AND INTEL DISCLAIMS ANY EXPRESS OR IMPLIED WARRANTY RELATING TO SALE AND/OR USE OF INTEL PRODUCTS, INCLUDING LIABILITY OR WARRANTIES RELATING TO FITNESS FOR A PARTICULAR PURPOSE, MERCHANTABILITY, OR INFRINGEMENT OF ANY PATENT, COPYRIGHT, OR OTHER INTELLECTUAL PROPERTY RIGHT.

Intel Corporation may have patents or pending patent applications, trademarks, copyrights, or other intellectual property rights that relate to the presented subject matter. The furnishing of documents and other materials and information does not provide any license, express or implied, by estoppel or otherwise, to any such patents, trademarks, copyrights, or other intellectual property rights.

Intel products are not intended for use in medical, life saving, life sustaining, critical control or safety systems, or in nuclear facility applications.

Intel may make changes to specifications and product descriptions at any time, without notice.

Designers must not rely on the absence or characteristics of any features or instructions marked "reserved" or "undefined." Intel reserves these for future definition and shall have no responsibility whatsoever for conflicts or incompatibilities arising from future changes to them.

The Intel® 31244 PCI-X to Serial ATA Controller may contain design defects or errors known as errata which may cause the product to deviate from published specifications. Current characterized errata are available on request.

Contact your local Intel sales office or your distributor to obtain the latest specifications and before placing your product order.

Copies of documents which have an ordering number and are referenced in this document, or other Intel literature may be obtained by calling 1-800-548-4725 or by visiting Intel's website at <http://www.intel.com>.

AnyPoint, AppChoice, BoardWatch, BunnyPeople, CablePort, Celeron, Chips, CT Media, Dialogic, DM3, EtherExpress, ETOX, FlashFile, i386, i486, i960, iCOMP, InstantIP, Intel, Intel Centrino, Intel logo, Intel386, Intel486, Intel740, IntelDX2, IntelDX4, IntelSX2, Intel Create & Share, Intel GigaBlade, Intel InBusiness, Intel Inside, Intel Inside logo, Intel NetBurst, Intel NetMerge, Intel NetStructure, Intel Play, Intel Play logo, Intel SingleDriver, Intel SpeedStep, Intel StrataFlash, Intel TeamStation, Intel Xeon, Intel XScale, IPLink, Itanium, MCS, MMX, MMX logo, Optimizer logo, OverDrive, Paragon, PC Dads, PC Parents, PDCharm, Pentium, Pentium II Xeon, Pentium III Xeon, Performance at Your Command, RemoteExpress, SmartDie, Solutions960, Sound Mark, StorageExpress, The Computer Inside., The Journey Inside, TokenExpress, VoiceBrick, VTune, and Xircom are trademarks or registered trademarks of Intel Corporation or its subsidiaries in the United States and other countries.

*Other names and brands may be claimed as the property of others.

Copyright © 2004, Intel Corporation

Contents

1	About This Document	15
1.1	Reference Documents	15
1.2	Terminology and Conventions	16
1.2.1	Representing Numbers	16
1.2.2	Fields	16
1.2.3	Specifying Bit and Signal Values	17
1.2.4	Signal Name Conventions	17
1.2.5	Terminology	18
2	Overview	21
2.1	Features	22
2.2	PCI-X Interface	22
2.3	PCI Commands Supported in M/S (PCI IDE) Mode	23
2.3.1	PCI Commands Supported in DPA Mode	24
2.4	Serial ATA Interface	25
2.5	Modes of Operation	27
2.5.1	Master/Slave Mode (or PCI IDE Mode)	27
2.5.2	Direct Port Access Mode	27
2.5.3	Selecting DPA or M/S Mode	28
2.5.4	DPA Mode Port Initialization	28
2.6	Serial EEPROM Interface	29
2.7	Extended Voltage Mode	29
2.8	ACTIVITY LEADS	30
2.8.1	Reference Clock Generation	31
2.9	High-End Storage Features	31
2.10	JTAG Interface	31
3	Serial EEPROM	32
3.1	Write Status Register (WRSR) Command	34
3.1.1	PROGRAM Command	35
3.1.2	READ Command	36
3.1.3	Write Disable (WRDI) Command	37
3.1.4	Read Status Register (RDSR) Command	38
3.1.5	Write Enable (WREN) Command	39
3.1.6	Sector Erase (SECT_ERASE) Command	40
3.1.7	CHIP_ERASE Command	41
3.1.8	Read ID Register (RDID) Command	42
3.1.9	Serial EEPROM SPI Interface – Address 90h	43
3.1.9.1	Programming Details	43
3.1.9.2	SPI Command / Control / Status Register - Address 90h	45
3.1.9.2.1	SPI Command	45
3.1.9.2.2	SPI Control	45
3.1.9.2.3	SPI Status	45
3.1.9.3	SPI Data Register - Address 94h	46
3.1.10	Detection of the EEPROM at Power-Up	46

4	Functional Blocks	48
4.1	Serial ATA.....	48
4.1.1	Out-of-Band Signaling	50
4.2	Operational Blocks.....	53
4.2.1	Serial Engine	54
4.2.2	Register Interface	54
4.2.3	DMA Controller	55
4.2.3.1	DMA Operation	57
4.2.3.2	Data Synchronization.....	58
4.2.3.3	DMA Error Conditions	59
4.2.3.4	DMA Throughput.....	60
4.2.4	Programmed I/O (PIO).....	62
4.2.5	Serial ATA II Native Command Queuing	63
4.2.5.1	Race-free Status Return Mechanism.....	64
4.2.5.2	Interrupt Aggregation	64
4.2.5.3	First Party DMA (FPDMA).....	65
5	Programming Interface.....	66
5.1	PCI IDE Mode.....	67
5.1.1	Native-PCI Mode	67
5.2	Direct Port Access Mode	69
5.2.1	Common Serial ATA Port Registers	70
5.2.2	Command Block Registers	70
5.2.3	Control Block Registers	71
5.2.4	DMA Controller Registers	71
5.2.5	SATA Superset Registers.....	72
5.3	ATA Command Processing	74
5.3.1	LBA Addressing in PCI IDE Mode	75
5.3.2	LBA Addressing in DPA Mode.....	76
5.4	Reset Initialization.....	77
5.5	Serial ATA BIST.....	79
5.5.1	Loopback Mode Testing	81
5.5.2	Transmit-Only Mode Testing	82
5.6	PCI Bus Error Conditions.....	83
5.6.1	Address and Attribute Parity Errors on the PCI Interface	83
5.6.2	Data Parity Errors on the PCI Interface	84
5.6.2.1	Outbound Read Request Data Parity Errors.....	84
5.6.2.1.1	Immediate Data Transfer	84
5.6.2.1.2	Split Response Termination.....	85
5.6.2.2	Outbound Write Request Data Parity Errors.....	86
5.6.2.2.1	Outbound Writes that are Not MSI (Message Signaled Interrupts).....	86
5.6.2.2.2	MSI Outbound Writes.....	86
5.6.2.3	Inbound Read Request Data Parity Errors	87
5.6.2.3.1	Immediate Data Transfer	87
5.6.2.4	Inbound Write Request Data Parity Errors.....	87
5.6.2.5	Outbound Read Completion Data Parity Errors.....	87
5.6.2.6	Split Completion Messages	88
5.6.3	Master Aborts on the PCI Interface	89
5.6.3.1	Master-Aborts Signaled by Intel® 31244 PCI-X to Serial ATA Controller as an Initiator	89
5.6.3.1.1	Master Aborts for Outbound Read or Write Request	89

5.6.3.2	Master-Aborts Signaled by Intel® 31244 PCI-X to Serial ATA Controller as a Target.....	90
5.6.3.2.1	Unsupported PCI Commands	90
5.6.3.2.2	PCI IDE Control Block Registers.....	90
5.6.4	Target Aborts on the PCI Interface	91
5.6.4.1	Target Aborts for Outbound Read Request or Outbound Write Request	91
5.6.4.2	Target-Aborts Signaled by Intel® 31244 PCI-X to Serial ATA Controller as a Target.....	92
5.6.4.2.1	Configuration Read and Write.....	92
5.6.4.2.2	I/O Read and Write	92
5.6.4.2.3	Memory Read.....	92
5.6.5	Corrupted or Unexpected Split Completions.....	93
5.6.5.1	Completer Address	93
5.6.5.2	Completer Attributes	93
5.6.6	SERR# Assertion and Detection.....	94
5.6.7	PCI Error Summary	95
5.7	Serial ATA Bus and Device Error Conditions	98
5.7.1	Serial ATA Device Error Conditions.....	98
5.7.2	Serial ATA Bus and Protocol Error Conditions	98
5.8	SATA Port Interrupt Generation.....	100
5.9	Message-Signaled Interrupts.....	102
5.9.1	Level-Triggered Versus Edge-Triggered Interrupts	102
5.10	Register Definitions.....	103
5.10.1	PCI IDE Mode Registers.....	103
5.10.2	PCI Configuration Registers	109
5.10.2.1	SU Vendor ID Register - SUVID	109
5.10.2.2	SU Device ID Register - SUDID.....	110
5.10.2.3	SU Command Register - SUCMD.....	111
5.10.2.4	SU Status Register - SUSR	112
5.10.2.5	SU Revision ID Register - SURID	113
5.10.2.6	SU Class Code Register - SUCCR.....	114
5.10.2.7	SU Cacheline Size Register - SUCLSR.....	115
5.10.2.8	SU Latency Timer Register - SULT	116
5.10.2.9	SU Header Type Register - SUHTR	117
5.10.2.10	SU BIST Register - SUBISTR.....	118
5.10.2.11	SU Base Address Register 0 - SUBAR0.....	119
5.10.2.12	SU Base Address Register 1 - SUBAR1.....	120
5.10.2.13	SU Base Address Register 2 - SUBAR2.....	121
5.10.2.14	SU Base Address Register 3 - SUBAR3.....	122
5.10.2.15	SU Base Address Register 4 - SUBAR4.....	123
5.10.2.16	SU Base Address Register 5 - SUBAR5.....	124
5.10.2.17	SU Subsystem Vendor ID Register - SUSVIR	125
5.10.2.18	SU Subsystem ID Register - SUSIR.....	126
5.10.2.19	SU Expansion ROM Base Address Register - SUEXROMBAR	127
5.10.2.20	SU Capabilities Pointer Register - SU_Cap_Ptr	128
5.10.2.21	SU Expansion ROM Base Address - SUEXROM	129
5.10.2.22	SU Interrupt Line Register - SUILR.....	130
5.10.2.23	SU Interrupt Pin Register - SUIPR.....	131
5.10.2.24	SU Minimum Grant Register - SUMGNT	132
5.10.2.25	SU Maximum Latency Register - SUMLAT.....	133
5.10.2.26	SPI Command Register - SPICMDR	134
5.10.2.27	SPI Control Register - SPICNTR	135

5.10.2.28	SPI Status Register - SPISTATR	136
5.10.2.29	SPI Data Register - SPIDATR	137
5.10.2.30	SU Extended Control and Status Register 0 - SUECSR0	138
5.10.2.31	SU DMA Control Status Register- SUDCSCR	139
5.10.2.32	SU Dummy Register SUDR	140
5.10.2.33	SU Interrupt Status Register SUI SR	141
5.10.2.34	SU Interrupt Mask Register SUIMR	142
5.10.2.35	SU Transaction Control SUTCR	143
5.10.2.36	SU Target Split Completion Message Enable Register SUTSCMER ..	144
5.10.2.37	SU Target Delayed/Split Request Pending Register SUDRPR	145
5.10.2.38	SU Transaction Control 2 Register SUTC2R	146
5.10.2.39	SU Master Deferred/Split Sequence Pending Register - SUMDSPR ..	148
5.10.2.40	SU Master Split Completion Message Received with Error Message Register - SUMSCMREMR	149
5.10.2.41	SU Arbiter Control - SUACR	150
5.10.2.42	SU PCI-X Capability Identifier Register - SUPCI-X_Cap_ID	151
5.10.2.43	SU PCI-X Next Item Pointer Register - SUPCI-X_Next_Item_Ptr	152
5.10.2.44	SU PCI-X Command Register - SUPCIXCMD	153
5.10.2.45	SU PCI-X Status Register - SUPCIXSR	154
5.10.2.46	SU PM Capability Identifier Register - SUPM_Cap_ID	156
5.10.2.47	SU PM Next Item Pointer Register - SUPM_Next_Item_Ptr	157
5.10.2.48	SU Power Management Capabilities Register - SUPMCR	158
5.10.2.49	SU Power Management Control/Status Register - SUPMCSR	159
5.10.2.50	SU MSI Capability Identifier Register - SUMSI_Cap_ID	160
5.10.2.51	SU MSI Next Item Pointer Register - SUMSI_Next_Ptr	161
5.10.2.52	SU MSI Message Control Register - SUMSI_Message_Control	162
5.10.2.53	SU MSI Message Address Register - SUMSI_Message_Address	163
5.10.2.54	SU MSI Message Upper Address Register - SUMSI_Message_Upper_Address	164
5.10.2.55	SU MSI Message Data Register- SUMSI_Message_Data	165
5.10.3	SU PCI IDE Mode Command Block Registers	166
5.10.3.1	SU IDE Data Port Register - SUIDR	166
5.10.3.2	SU IDE Error Register - SUIER	167
5.10.3.3	SU IDE Features Register - SUIFR	168
5.10.3.4	SU IDE Sector Count Register - SUI SCR	169
5.10.3.5	SU IDE Sector Number Register - SUI SNR	170
5.10.3.6	SU IDE Cylinder Low Register - SUI CLR	171
5.10.3.7	SU IDE Cylinder High Register - SUI CHR	172
5.10.3.8	SU IDE Device/Head Register - SUIDR	173
5.10.3.9	SU IDE Status Register - SUI SR	174
5.10.3.10	SU IDE Command Register - SUI CR	175
5.10.4	SU PCI IDE Mode Control Block Registers	176
5.10.4.1	SU IDE Device Control Register - SUIDCR	176
5.10.4.2	SU IDE Alternate Status Register - SUI ASR	177
5.10.5	SU PCI IDE Mode DMA Registers	178
5.10.5.1	SU IDE Channel 0 DMA Command Register - SUI CDCR0	178
5.10.5.2	SU IDE Channel 0 DMA Status Register - SUI CDSR0	179
5.10.5.3	SU IDE Channel 0 DMA Descriptor Table Pointer Register - SUI CDDTPR0	180
5.10.5.4	SU IDE Channel 1 DMA Command Register - SUI CDCR1	181
5.10.5.5	SU IDE Channel 1 DMA Status Register - SUI CDSR1	182
5.10.5.6	SU IDE Channel 1 DMA Descriptor Table Pointer Register - SUI CDDTPR1	183
5.10.6	SU PCI DPA Mode Registers	184

5.10.7	SU PCI DPA Mode Base Address Registers	192
5.10.7.1	SU PCI DPA Base Address Register 0 - SUPDBAR0	192
5.10.7.2	SU PCI DPA Upper Base Address Register 0 - SUPDUBAR0	193
5.10.8	SU PCI DPA Mode Common SATA Port Registers	194
5.10.8.1	SU PCI DPA Interrupt Pending Register - SUPDIPR	194
5.10.8.2	SU PCI DPA Interrupt Mask Register - SUPDIMR	200
5.10.9	SU PCI DPA Mode Command Block Registers	203
5.10.9.1	SU PCI DPA Data Port Register - SUPDDR	203
5.10.9.2	SU PCI DPA Error Register - SUPDER	204
5.10.9.3	SU PCI DPA Features Register - SUPDFR	205
5.10.9.4	SU PCI DPA Sector Count Register - SUPDSCR	206
5.10.9.5	SU PCI DPA Sector Number Register - SUPDSNR	207
5.10.9.6	SU PCI DPA Cylinder Low Register - SUPDCLR	208
5.10.9.7	SU PCI DPA Cylinder High Register - SUPDCHR	209
5.10.9.8	SU PCI DPA Device/Head Register - SUPDDR	210
5.10.9.9	SU PCI DPA Status Register - SUPDSR	211
5.10.9.10	SU PCI DPA Command Register - SUPDCR	212
5.10.10	SU PCI DPA Mode Control Block Registers	213
5.10.10.1	SU PCI DPA Alternate Status Register - SUPDASR	213
5.10.10.2	SU PCI DPA Device Control Register - SUPDDCTLR	214
5.10.11	SU PCI DPA Mode DMA Registers	215
5.10.11.1	SU PCI DPA Upper DMA Descriptor Table Pointer Register - SUPDUDDTPR	215
5.10.11.2	SU PCI DPA Upper DMA Data Pointer Register - SUPDUddbPR	216
5.10.11.3	SU PCI DPA DMA Command Register - SUPDDCMDR	217
5.10.11.4	SU PCI DPA DMA Status Register - SUPDDSR	218
5.10.11.5	SU PCI DPA DMA Descriptor Table Pointer Register - SUPDDDTPR	219
5.10.12	SU PCI DPA Mode Superset Registers	220
5.10.12.1	SU PCI DPA SATA SStatus Register - SUPDSSSR	220
5.10.12.2	SU PCI DPA SATA SError Register - SUPDSSER	222
5.10.12.3	SU PCI DPA SATA SControl Register - SUPDSSCR	225
5.10.12.4	SU PCI DPA Set Device Bits Register - SUPDSDBR	226
5.10.12.5	SU PCI DPA PHY Feature Register - SUPDPFR	227
5.10.12.6	SU PCI DPA BIST FIS Control and Status Register - SUPDBFCSR	228
5.10.12.7	SU PCI DPA BIST Errors Register - SUPDBER	231
5.10.12.8	SU PCI DPA BIST Frames Register - SUPDBFR	232
5.10.12.9	SU PCI DPA Host BIST Data Low Register - SUPDHBDLR	233
5.10.12.10	SU PCI DPA Host BIST Data High Register - SUPDHBDHR	234
5.10.12.11	SU PCI DPA Device BIST Data Low Register - SUPDDBDLR	235
5.10.12.12	SU PCI DPA Device BIST Data High Register - SUPDDBDHR	236
5.10.12.13	SU PCI DPA Queuing Table Base Address Register Low - SUPDQTBARL	237
5.10.12.14	SU PCI DPA Queuing Table Base Address Register High - SUPDQTBARH	238
5.10.12.15	SU PCI DPA DMA Setup FIS Control and Status Register - SUPDDSFCR	239
5.10.12.16	SU PCI DPA Host DMA Buffer Identifier Low Register - SUPDHDBILR	240
5.10.12.17	SU PCI DPA Host DMA Buffer Identifier High Register - SUPDHDBIHR	241
5.10.12.18	SU PCI DPA Host Reserved DWORD Register 0 - SUPDHRDR0	242
5.10.12.19	SU PCI DPA Host DMA Buffer Offset Register - SUPDHDBOR	243
5.10.12.20	SU PCI DPA Host DMA Transfer Count Register - SUPDHDTCR	244
5.10.12.21	SU PCI DPA Host Reserved DWORD Register 1 - SUPDHRDR1	245



5.10.12.22SU PCI DPA Device DMA Buffer Identifier	
Low Register - SUPDDDBILR.....	246
5.10.12.23SU PCI DPA Device DMA Buffer Identifier	
High Register - SUPDDDBIHR	247
5.10.12.24SU PCI DPA Host Reserved DWORD Register 0 - SUPDHRDR0.....	248
5.10.12.25SU PCI DPA Device DMA Buffer Offset Register - SUPDDDBOR.....	249
5.10.12.26SU PCI DPA Device DMA Transfer Count Register - SUPDDDTCR .	250
5.10.12.27SU PCI DPA Device Reserved DWORD Register 1 - SUPDDRDR1 .	251

Figures

1	Intel® 31244 PCI-X to Serial ATA Controller Block Diagram	21
2	Serial ATA Unit Block Diagram	26
3	Common LED and Serial EEPROM Options	30
4	Serial EEPROM Interface	32
5	Write Status Register (WRSR) Operation	34
6	Write Memory (PROGRAM) Operation, 4 Byte	35
7	Read Memory (READ) Operation, 4 Byte	36
8	Write Disable (WRDI) Operation	37
9	Read Status Register (RDSR) Operation	38
10	Write Enable (WREN) Operation	39
11	Sector Erase (SECT_ERASE) Operation	40
12	Chip Erase (CHIP_ERASE) Operation	41
13	Read ID Register (RDID) Operation	42
14	SATA Protocol Layers	49
15	Analog Front End (AFE) Cabling and OOB Signals	50
16	OOB Signals Timings	50
17	COMRESET Sequence	51
18	COMINIT Sequence	52
19	SATA Port Block Diagram	53
20	DMA Descriptor Table	56
21	DMA Arbitration	60
22	SATA Unit Register Mapping in Native-PCI Mode	68
23	SATA Unit Register Mapping in Direct Port Access Mode	69
24	Common Serial ATA Port Registers	70
25	Command Block Registers for SATA Port 0	70
26	Control Block Registers for SATA Port 0	71
27	DMA Controller Registers for SATA Port 0	71
28	Far-End Retimed Loopback Setup	79
29	Far-End Analog Loopback Setup	80
30	Near-End Analog Loopback Setup	80
31	SATA Unit Interrupt Generation Block Diagram	101
32	SU in PCI IDE Mode Interface Configuration Header Format	103
33	SATA Unit Interface Extended Configuration Header Format (PCI-X Capability)	104
34	SU in PCI IDE Mode Interface Extended Configuration Header Format (Power Management)	104
35	SU in PCI IDE Mode Interface Extended Configuration Header Format (MSI Capability)	105

Tables

1	Reference Documents.....	15
2	Terms and Definitions.....	18
3	PCI Commands Supported in PCI IDE Mode.....	23
4	PCI Commands Supported in DPA Mode.....	24
5	DPA Mode Interface Features.....	27
6	BAR Register usage in M/S and DPA Modes.....	28
7	Normal Voltage Mode.....	29
8	Extended Voltage Mode.....	29
9	Serial EEPROM Interface Pins.....	33
10	SCLK Frequency.....	33
11	Serial EEPROM Commands.....	33
12	Block Write Protect Bits.....	34
13	Byte Enables on ROM Memory Reads.....	36
14	Status Register Format (Refer to Atmel* AT25F1024 Datasheet).....	38
15	Write and Read Command Types.....	44
16	PCI Byte Enables on Read and Write Operations.....	44
17	SPI Command.....	45
18	SPI Control.....	45
19	SPI Status.....	45
20	SPI Data Register - Address 94h.....	46
21	Interrupt /Activity Status Combinations.....	58
22	PCI-X Bus Efficiency for Reads.....	60
23	PCI-X Bus Efficiency for Writes.....	60
24	Read Transfer Rate on PCI-X Bus.....	61
25	Write Transfer Rate on PCI-X Bus.....	61
26	SATA Port Register Mapping in Native PCI IDE Mode.....	67
27	SATA Superset Registers for SATA Port 0 in DPA Mode.....	73
28	28-Bit LBA Address Bit Layout in PCI IDE Mode.....	75
29	48-Bit LBA Address Bit Layout.....	75
30	48-Bit Address Loading Sequence.....	75
31	28-Bit LBA Address Bit Layout in DPA Mode.....	76
32	48-Bit LBA Address Bit Layout in DPA Mode.....	76
33	31244 Controller Error Reporting Summary - PCI Interface.....	95
34	31244 Controller Serial ATA Protocol and Bus Error Conditions.....	98
35	SATA Unit PCI Configuration Space Registers.....	106
38	SATA DMA Registers in PCI IDE Mode.....	108
36	SATA Command Block Registers in PCI IDE Mode.....	108
37	SATA Control Block Registers in PCI IDE Mode.....	108
39	SU Vendor ID Register - SUVID.....	109
40	SU Device ID Register - SUDID.....	110
41	SU Command Register - SUCMD.....	111
42	SU Status Register - SUSR.....	112
43	SU Revision ID Register - SURID.....	113
44	SU Class Code Register - SUCCR.....	114
45	SU Cacheline Size Register - SUCLSR.....	115
46	SU Latency Timer Register - SULT.....	116
47	SU Header Type Register - SUHTR.....	117
48	SU BIST Register - SUBISTR.....	118
49	SU Base Address Register 0 - SUBAR0.....	119

50	SU Base Address Register 1 - SUBAR1	120
51	SU Base Address Register 2 - SUBAR2	121
52	SU Base Address Register 3 - SUBAR3	122
53	SU Base Address Register 4 - SUBAR4	123
54	SU Base Address Register 5 - SUBAR5	124
55	SU Subsystem Vendor ID Register - SUSVIR	125
56	SU Subsystem ID Register - SUSIR	126
57	SU Expansion ROM Base Address Register - SUEXROMBAR	127
58	SU Capabilities Pointer Register - SU_Cap_Ptr	128
59	SU Expansion ROM Base Address - SUEXROM	129
60	SU Interrupt Line Register - SUILR	130
61	SU Interrupt Pin Register - SUIPR	131
62	SU Minimum Grant Register - SUMGNT	132
63	SU Maximum Latency Register - SUMLAT	133
64	SPI Command Register - SPICMDR	134
65	SPI Control Register - SPICNTR	135
66	SPI Status Register - SPISTATR	136
67	SPI Data Register - SPIDATR	137
68	SU Extended Control and Status Register 0 - SUECSR 0	138
69	SU DMA Control Status Register - SUDCSCR 0	139
70	SU Dummy Register - SUDR	140
71	SU Interrupt Status Register - SUISR	141
72	SU Interrupt Mask Register - SUIMR	142
73	SU Transaction Control Register - SUTCR	143
74	SU Target Split Completion Message Enable Register- SUTSCMER	144
75	SU Target Split Completion Message Enable Register- SUTSCMER	145
76	SU Transaction Control 2 Register- SUTC2R	146
77	SU Master Split Completion Message Received with Error Message Register - SUMSCMREMR	148
78	SU Master Split Completion Message Received with Error Message Register - SUMSCMREMR	149
79	SU Arbiter Control Register SUACR	150
80	SU PCI-X Capability Identifier Register - SUPCI-X_Cap_ID	151
81	SU PCI-X Next Item Pointer Register - SUPCI-X_Next_Item_Ptr	152
82	SU PCI-X Command Register - SUPCIXCMD	153
83	SU PCI-X Status Register - SUPCIXSR	154
84	SU PM Capability Identifier Register - SUPM_Cap_ID	156
85	SU PM Next Item Pointer Register - SUPM_Next_Item_Ptr	157
86	SU Power Management Capabilities Register - SUPMCR	158
87	SU Power Management Control/Status Register - SUPMCSR	159
88	SU MSI Capability Identifier Register - SUMSI_Cap_ID	160
89	SU MSI Next Item Pointer Register - SUMSI_Next_Ptr	161
90	SU MSI Message Control Register - SUMSI_Message_Control	162
91	SU MSI Message Address Register - SUMSI_Message_Address	163
92	SU MSI Message Upper Address Register - SUMSI_Message_Upper_Address	164
93	SU MSI Message Data Register - SUMSI_Message_Data	165
94	SU IDE Data Port Register - SUIDR	166
95	SU IDE Error Register - SUIER	167
96	SU IDE Features Register - SUIFR	168
97	SU IDE Sector Count Register - SUISCR	169

98	SU IDE Sector Number Register - SUISNR	170
99	SU IDE Cylinder Low Register - SUICLR	171
100	SU IDE Cylinder High Register - SUICHR	172
101	SU IDE Device/Head Register - SUIDHR	173
102	SU IDE Status Register - SUI SR	174
103	SU IDE Command Register - SUICR	175
104	SU IDE Device Control Register - SUIDCR	176
105	SU IDE Alternate Status Register - SUIASR	177
106	SU IDE Channel 0 DMA Command Register - SUICDCR0	178
107	SU IDE Channel 0 DMA Status Register - SUICDSR0	179
108	SU IDE Channel 0 DMA Descriptor Table Pointer Register - SUICDDTPR0	180
109	SU IDE Channel 1 DMA Command Register - SUICDCR1	181
110	SU IDE Channel 1 DMA Status Register - SUICDSR1	182
111	SU IDE Channel 1 DMA Descriptor Table Pointer Register - SUICDDTPR1	183
112	Configuration Space Comparison	184
113	SATA Port Registers Mapping in PCI DPA Mode	185
114	SU PCI DPA Base Address Register 0 - SUDBAR0	192
115	SU PCI DPA Upper Base Address Register 0 - SUPDUBAR0	193
116	SU PCI DPA Interrupt Pending Register - SUPDIPR	194
117	SU PCI DPA Interrupt Mask Register - SUPDIMR	200
118	SU PCI DPA Data Port Register - SUPDDR	203
119	SU PCI DPA Error Register - SUPDER	204
120	SU PCI DPA Features Register - SUPDFR	205
121	SU PCI DPA Sector Count Register - SUPDSCR	206
122	SU PCI DPA Sector Number Register - SUPDSNR	207
123	SU PCI DPA Cylinder Low Register - SUPDCLR	208
124	SU PCI DPA Cylinder High Register - SUPDCHR	209
125	SU PCI DPA Device/Head Register - SUPDDHR	210
126	SU PCI DPA Status Register - SUPDSR	211
127	SU PCI DPA Command Register - SUPDCR	212
128	SU PCI DPA Alternate Status Register - SUPDASR	213
129	SU PCI DPA Device Control Register - SUPDDCTLR	214
130	SU PCI DPA Upper DMA Descriptor Table Pointer Register - SUPDUDDTPR	215
131	SU PCI DPA Upper DMA Data Buffer Pointer Register - SUPDUDDPR	216
132	SU PCI DPA DMA Command Register - SUPDDCMDR	217
133	SU PCI DPA DMA Status Register - SUPDDSR	218
134	SU PCI DPA DMA Descriptor Table Pointer Register - SUPDDDTPR	219
135	SU PCI DPA SATA SStatus Register - SUPDSSSR	220
136	SU PCI DPA SATA SError Register - SUPDSSER	222
137	SU PCI DPA SATA SControl Register - SUPDSSCR	225
138	SU PCI DPA Set Device Bits Register - SUPDSDBR	226
139	SU PCI DPA PHY Feature Register - SUPDPFR	227
140	SU PCI DPA BIST FIS Control and Status Register - SUPDBFCSR	228
141	SU PCI DPA BIST Errors Register - SUPDBER	231
142	SU PCI DPA BIST Frames Register - SUPDBFR	232
143	SU PCI DPA Host BIST Data Low Register - SUPDHBDLR	233
144	SU PCI DPA Host BIST Data High Register - SUPDHBDR	234
145	SU PCI DPA Device BIST Data Low Register - SUPDDBDLR	235
146	SU PCI DPA Device BIST Data High Register - SUPDDBDR	236
147	SU PCI DPA Device BIST Data High Register - SUPDDBDR	237



148	SU PCI DPA Device BIST Data High Register - SUPDDBDHR	238
149	SU PCI DPA DMA Setup FIS Control and Status Register - SUPDDSFCRSR	239
150	SU PCI DPA Host DMA Buffer Identifier Low Register - SUPDHDBILR	240
151	SU PCI DPA Host DMA Buffer Identifier High Register - SUPDHDBIHR	241
152	SU PCI DPA Host Reserved DWORD Register 0 - SUPDHRDR 0.....	242
153	SU PCI DPA Host DMA Buffer Offset Register - SUPDHDBOR	243
154	SU PCI DPA Host DMA Transfer Count Register - SUPDHDTCR.....	244
155	SU PCI DPA Host Reserved DWORD Register 1- SUPDHRDR 1.....	245
156	SU PCI DPA Device DMA Buffer Identifier Low Register - SUPDDDBILR.....	246
157	SU PCI DPA Device DMA Buffer Identifier High Register - SUPDDDBIHR	247
158	SU PCI DPA Device Reserved DWORD Register 0 - SUPDDRDR0	248
159	SU PCI DPA Device DMA Buffer Offset Register - SUPDDDBOR.....	249
160	SU PCI DPA Device DMA Transfer Count Register - SUPDDTCR	250
161	SU PCI DPA Device Reserved DWORD Register 1 - SUPDDRDR1	251

Revision History

Date	Revision	Description
April 2004	-006	<p>Removed Section 2.9, "Spread Spectrum Clocking" (page 31).</p> <p>Removed definitions of "SSC" and "SSCEN" from Table 2, "Terms and Definitions" on page 18.</p> <p>Removed references to "SSC" and "SSCEN" in Section 5.10.12.5, "SU PCI DPA PHY Feature Register - SUPDPFR" on page 227 and Table 139, "SU PCI DPA PHY Feature Register - SUPDPFR" on page 227.</p>
February 2004	-005	Minor corrections.
January 2004	-004	Updated several register definitions.
March 2003	-003	<p>Corrected Figure 2.</p> <p>Modified Section 3.8.6 and Section 3.12.2.36.</p> <p>Updated Table 74.</p> <p>Recreated Figures 14, 15, 16, 17, 27, 28 and 29.</p>
December 2002	-002	<p>In Section 2, added "Serial EEPROM Interface" sub-section.</p> <p>Updated Section 1.1, "Reference Documents."</p> <p>Updated Table 30, "SATA Unit PCI Configuration Space Registers", to include SPICMDR, SPICNTR, SPISTATR, and SPIDATR.</p>
October 2002	-001	Initial release of this document.

About This Document

1

1.1 Reference Documents

Table 1. Reference Documents

Documentation	Document Number/Source
<i>Intel® 31244 PCI-X to Serial ATA Controller Datasheet</i>	273595
<i>Intel® 31244 PCI-X to Serial ATA Controller Design Guide</i>	273651
<i>Intel® 31244 PCI-X to Serial ATA Controller Red Canyon CRB Manual</i>	273801
<i>Atmel* Serial Memory Specification AT25F512/AT25F1024</i>	http://www.atmel.fi/atmel/acrobat/doc1440.pdf
<i>ATA Attachment with Packet Interface-6 (ATA/ATAPI-6) Specification, ANSI/INCITS #361-2002</i>	http://www.techstreet.com/cgi-bin/detail?product_id=932242
<i>Serial ATA Specification</i>	http://www.serialata.org
<i>Serial ATA II: Extensions to Serial ATA 1.0 Specification</i>	http://www.serialata.org/collateral/index.shtml
<i>PCI Local Bus Specification, Revision 2.2</i>	http://www.pcisig.com
<i>PCI-X Addendum to the PCI Local Bus Specification, Revision 1.0a</i>	http://www.pcisig.com
<i>PCI Bus Power Management Interface Specification, Revision 1.1</i>	http://www.pcisig.com
<i>PCI IDE Specification, Revision 1.0</i>	http://www.bswd.com/pciide.pdf
<i>STMicroelectronics* M25P10 Serial Flash Memory</i>	http://us.st.com/stonline/books/pdf/docs/7022.pdf

1.2 Terminology and Conventions

1.2.1 Representing Numbers

All numbers in this document may be assumed to be Base10, unless designated otherwise. In text, numbers in Base16 are represented as 'nnnH', where the 'H' signifies hexadecimal. In pseudo code descriptions, hexadecimal numbers are represented in the form 0x1234 ABCD. Binary numbers are not explicitly identified, but are assumed when bit operations or bit ranges are used.

1.2.2 Fields

<i>Reserved:</i>	Is a field that may be used by an implementation. When the initial value of a reserved field is supplied by software, this value must be zero. Software should not modify reserved fields or depend on any values in reserved fields.
<i>Read/Write:</i>	May be written to a new value following initialization. This field may always be read to return the current value.
<i>Read Only:</i>	May be read to return the current value. Writes to <i>read only</i> fields are treated as no-op operations and will not change the current value, nor result in an error condition.
<i>Read/Clear:</i>	May also be read to return the current value. A write to a <i>read/clear</i> field with the data value of 0 will cause no change to the field. A write to a <i>read/clear</i> field with a data value of 1 will cause the field to be cleared (reset to the value of 0). For example, when a <i>read/clear</i> field has a value of FOH, and a data value of 55H is written, the resultant field will be A0H.
<i>Read/Set:</i>	May also be read to return the current value. A write to a <i>read/set</i> field with the data value of 0 will cause no change to the field. A write to a <i>read/set</i> field with a data value of 1 will cause the field to be set (set to the value of 1). For example, when a <i>read/set</i> field has a value of FOH, and a data value of 55H is written, the resultant field will be F5H.
<i>Writeonce/Readonly:</i>	May be written to a new value once following initialization. After the this write has occurred, the <i>writeonce/readonly</i> field will treat all subsequent writes as no-op operations and will not change the current value or result in an error condition. The field may always be read to return the current value.

1.2.3 Specifying Bit and Signal Values

The terms *set* and *clear* in this specification refer to bit values in register and data structures. When a bit is set, its value is 1; when the bit is clear, its value is 0. Likewise, *setting* a bit means giving it a value of 1 and *clearing* a bit means giving it a value of 0.

The terms *assert* and *deassert* refer to the logically active or inactive value of a signal or bit, respectively.

1.2.4 Signal Name Conventions

All signal names use the PCI signal name convention of using the '#' symbol at the end of a signal name to indicate that the signal active state occurs when it is at a low voltage. The absence of the '#' symbol indicates that the signal active state occurs when it is at a high voltage.

1.2.5 Terminology

To aid the discussion of the GD31244 controller architecture, the following terminology is used:

Table 2. Terms and Definitions (Sheet 1 of 2)

Term	Definition
BAR	Base Address Register
BIST	Built-In Self Test
CFG	Configure
CRB	Customer Reference Board
Differential Signal	signal is comprised of a positive conductor and a negative conductor. The differential signal is the voltage on the positive conductor minus the voltage on the negative conductor (i.e., TX+ – TX-).
DMA	Direct Memory Access
Downstream	At or toward a PCI bus with a higher number (after configuration).
DPA Direct Port Access	Refers to a mode that allows more efficient access to the GD31244 registers. See also PCI IDE.
DWORD	32-bit data word.
HBA	Host Bus Adapter
Host processor:	Processor located upstream from the GD31244 controller.
Inbound Transactions	Transactions that are aimed at the GD31244 controller by an external bus master device.
ISI	Inter-symbol interference. Data-dependent deterministic jitter caused by the time propagated at different rates by the transmission media. This translates into high-frequency, data-dependent, jitter.
JEDEC	Provides standards for the semiconductor industry.
Jitter	Jitter is a high-frequency, semi-random displacement of a signal from its ideal location.
M/S	Master/Slave. Refers to a legacy ATA mode that uses the traditional methods for accessing the ATA and the DMA registers (see also DPA).
BAR	Base Address Register
MR	Memory Read
MRL	Memory Read Line
MRM	Memory Read Multiple
MSI	Message Signalled Interrupts
MW	Memory Write
MWI	Memory Write and Invalidate
Network	The trace of a PCB that completes an electrical connection between two or more components.
Outbound Transactions	Transactions that are initiated by the controller to another target device.
PATA	Parallel ATA
PBGA	Plastic Ball Grid Array
PERR#	Parity error
PIO	Programmed I/O

Table 2. Terms and Definitions (Sheet 2 of 2)

Term	Definition
PLL	Phase Lock Loop
PLL	This block is used to synchronize an internal clocking reference so that the input high-speed data stream may be properly decoded
PRD	Physical Region Description
Prepreg	Material used for the lamination process of manufacturing PCBs. It consists of a layer of epoxy material that is placed between two cores. This layer melts into epoxy layer of epoxy material that is placed between two cores. This layer melts into epoxy when heated and forms around adjacent traces.
QWORD	64-bit data word.
RDID	Read Manufacturer and Product ID
RDSR	Read Status Register
RX	This is a receiver port contains the basic high-speed receiver electronics.
RX + / RX -	Inbound high-speed differential signals connected to the serial ATA cable.
RxData	10b encoding Serially encoded 10b data attached to the high-speed serial differential line receiver. The 8B/10B encoding scheme transmits eight bits as a 10-bit code group. This encoding is used with Gigabit Ethernet, Fibre Channel and InfiniBand.
SATA	Serial ATA
SECT	Sector
SERR#	SERR is the System Error Signal on the PCI bus.
SPI	Serial Peripheral Interface. SPI is used to access the GD31244 EEPROM.
Stub	Branch from a trunk terminating at the pad of an agent.
Termination Calibration	Terminate the high-speed serial cable. This block is used to synchronize an internal clocking reference so that the input high-speed data stream may be properly decoded.
TX	This is a transmit port that contains the basic high-speed driver electronics.
TX + / TX -	Outbound high-speed differential signals connected to the serial ATA cable.
TxData	Serially encoded 10b data attached to the high-speed serial differential line driver.
Upstream	At or toward a PCI bus with a lower number (after configuration).
WEN	Write Enable
WPEN	Write Protection Enable
WRDI	Reset Write Enable Latch
WREN	Write Enable
WRSR	Write Status Register



This Page Left Intentionally Blank

Overview

2

The Intel® 31244 PCI-X to Serial ATA Controller (GD31244) is a single-chip solution for a PCI-X to Serial ATA Controller. It accepts host commands through the PCI-X bus, processes them and transmits them to one of four Serial ATA targets. The GD31244 supports Serial ATA speeds of 1.5 Gbits/s of 8b/10b encoded data which is equivalent to 150 Mbytes/s of raw data. The GD31244 derives its Serial ATA clocks from an internal PLL with a reference clock of 37.5 MHz. On the 64-bit PCI-X bus, when run at the maximum frequency of 133 MHz, the GD31244 supports a maximum burst transfer rate of 1064 Mbytes/s.

The GD31244 controller may be used to build standalone PCI-X HBA cards to interface Serial ATA Disk Drives, CD-ROMs, DVD ROMs or Tape drives. The GD31244 is completely software compatible with all existing operating systems which support ATA interfaces: Windows*, Windows NT*, Linux*, Solaris*, Unix*, etc. In PC systems, the GD31244 may also be configured to provide additional storage capacity to systems already supporting four ATA targets. In non-PC systems, the GD31244 may be used as a generic storage controller in servers, RAID subsystems and Network Attached Storage (NAS) systems. The ease-of-use, flexibility, performance and low cost of the GD31244 make it an ideal choice for all of these applications.

In addition to PCI IDE mode, the GD31244 supports a new programming interface, referred to as Direct Port Access Mode. In this new mode, the SATA ports are set up to operate independently, for example no master/slave emulation is done as in PCI IDE mode. In this mode the SATA ports registers are memory-mapped.

Figure 1. Intel® 31244 PCI-X to Serial ATA Controller Block Diagram

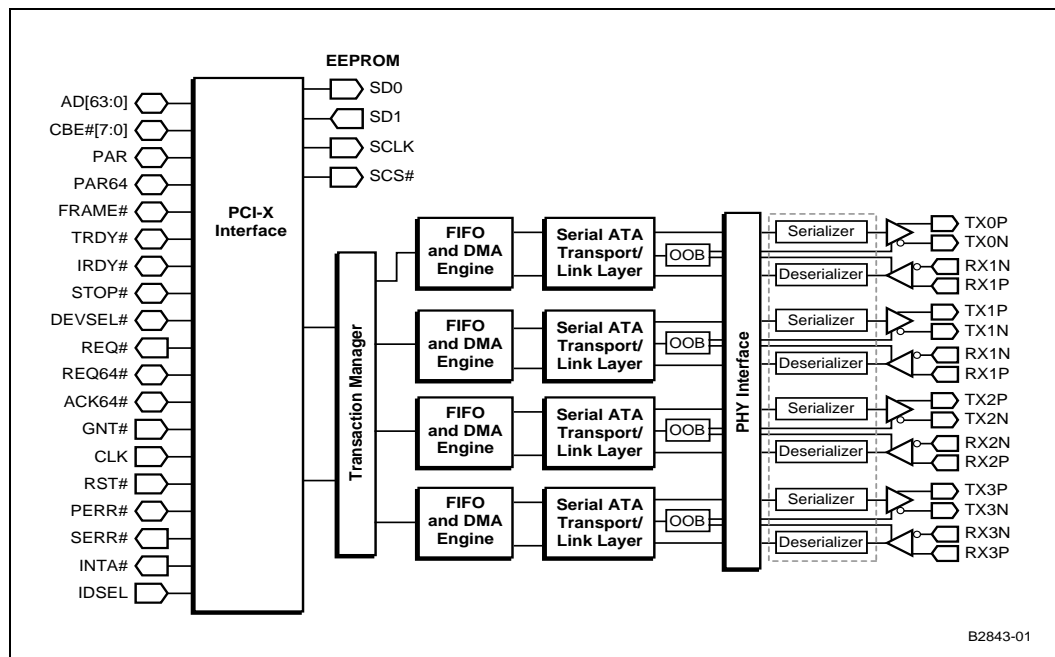

2.1 Features

- Four SATA Ports at 1.5 Gbits/s
- Compliant with *Serial ATA: High speed Serialized AT Attachment Specification*, Revision 1.0e
- 64-bit/133MHz PCI-X Bus. Backwards compatible to PCI 32-bit/33 MHz and 64-bit/66 MHz
- Supports native PCI IDE
- Hot-Plug Drives
- Supports Master/Slave Mode for Compatibility with existing Operating Systems
- Supports SATA Direct Port Access
- Independent DMA Masters for each SATA Port
- 3.3V and 2.5V Supply, 2W maximum

2.2 PCI-X Interface

The 64-bit, 133 MHz PCI-X interface is fully compliant with the *PCI Local Bus Specification*, Revision 2.2 and the *PCI-X Addendum to the Local Bus Specification*, Revision 1.0. The PCI-X bus supports up to 1064 Mbytes/s transfer rate of burst data. The GD31244 is backwards compatible with 32-bit/33 MHz, 32-bit/66 MHz and 64-bit/66 MHz operation. The GD31244 contains internal registers and support circuitry to implement complete Plug-n-Play functionality, which allows hardware and firmware to resolve all setup conflicts for the user. The GD31244 supports both slave and master data transfers.

During system initialization, the host system Configuration Manager reads the configuration space of each PCI-X device. After hardware reset, the GD31244 only responds to PCI-X Configuration cycles in anticipation of being initialized by the Configuration Manager. Each PCI-X device is addressable individually by the use of unique IDSEL signals which, when asserted, indicate that a configuration read or write is occurring to this device. The Configuration Manager reads the setup registers of each device on the PCI-X bus and then, based on this information, assigns system resources to each supported function through Type 0 configuration reads and writes. Type 1 configuration cycles are ignored. This scheme allows the GD31244 to be relocated in the memory and I/O space. Interrupts, DMA Channels and other system resources may be reallocated appropriately.

2.3 PCI Commands Supported in M/S (PCI IDE) Mode

Table 3. PCI Commands Supported in PCI IDE Mode

PCI Command Encoding	PCI Command Type	PCI-X Command Type	Claimed on Inbound Transactions on PCI Bus?	Generated by Outbound Transactions on PCI Bus?
0000	Interrupt Acknowledge	Interrupt Acknowledge	no	no
0001	Special Cycle	Special Cycle	No	No
0010	I/O Read	I/O Read	No	No
0011	I/O Write	I/O Write	Yes	No
0100	Reserved	Reserved	No	No
0101	Reserved	Reserved	No	No
0110	Memory Read	Memory Read DWORD	Yes	Yes
0111	Memory Write	Memory Write	Yes	Yes
1000	Reserved	Alias to Memory Read Block	PCI-X = Yes PCI = No	No
1001	Reserved	Alias to Memory Write Block	PCI-X = Yes PCI = No	No
1010	ConfigurationRead	ConfigurationRead	Yes	No
1011	Configuration Write	Configuration Write	Yes	No
1100	Memory Read Multiple	Split Completion	Yes	PCI-X = No PCI = Yes
1101	Dual Address Cycle	Dual Address Cycle	Yes	Yes
1110	Memory Read Line	Memory Read Block	Yes	Yes
1111	Memory Write	Memory Write Block	Yes	Yes

2.3.1 PCI Commands Supported in DPA Mode

In DPA Mode, the SATA Unit registers are mapped in memory space using one base address register. Each port supports its own DMA and each SATA port device may be independently controlled. Table 4 shows the PCI and PCI-X commands supported for both inbound and outbound transactions when in DPA Mode.

Table 4. PCI Commands Supported in DPA Mode

PCI Command Encoding	PCI Command Type	PCI-X Command Type	Claimed on Inbound Transactions on PCI Bus?	Generated by Outbound Transactions on PCI Bus?
0000	Interrupt Acknowledge	Interrupt Acknowledge	No	No
0001	Special Cycle	Special Cycle	No	No
0010	I/O Read	I/O Read	No	No
0011	I/O Write	I/O Write	No	No
0100	Reserved	Reserved	No	No
0101	Reserved	Reserved	No	No
0110	Memory Read	Memory Read DWORD	Yes	Yes
0111	Memory Write	Memory Write	Yes	Yes
1000	Reserved	Alias to Memory Read Block	PCI-X = Yes PCI = No	No
1001	Reserved	Alias to Memory Write Block	PCI-X = Yes PCI = No	No
1010	Configuration Read	Configuration Read	Yes	No
1011	Configuration Write	Configuration Write	Yes	No
1100	Memory Read Multiple	Split Completion	Yes	PCI-X = No PCI = Yes
1101	Dual Address Cycle	Dual Address Cycle	Yes	Yes
1110	Memory Read Line	Memory Read Block	Yes	Yes
1111	Memory Write Invalidate	Memory Write Block	Yes	Yes

For inbound transactions in conventional PCI, Memory Read transactions are disconnected-with-data on the first data phase. For example, when a Memory Read transaction is requesting more than one DWORD, the transaction is disconnected on the first DWORD. The GD31244 controller aliases Memory Read Line (MRL) and Memory Read Multiple (MRM) to Memory Read. Memory Write (MW) is also disconnected-with-data on the first data phase. For example, only the first DWORD is claimed and then the transaction is disconnected. The GD31244 controller aliases Memory Write and Invalidate (MWI) to Memory Write. In PCI-X mode, Memory Read Block and Memory Write Block are single-phase-disconnected.

2.4 Serial ATA Interface

Four 1.5 Gbits/s Serial ATA ports are located on the GD31244, to support point-to-point connectivity to:

- Disk Drives
- CD ROMs
- DVD ROMs
- Any other Serial ATA target device

Each port is compliant with the *Serial ATA Specification*. High-speed differential-duplex serial lines send 8B/10B encoded data to and from the GD31244 and the target at a maximum raw data rate of 1.2 Gbits/s (150 Mbytes/s). Copies of the target Task File Registers are maintained on the GD31244 and transferred as needed to the target. The Serial ATA protocol is software compatible with all existing operating systems that support ATA devices. However, performance and reliability are improved, since all data is CRC checked.

The GD31244 may be configured in a high-performance mode where each SATA port is addressed individually, eliminating the performance bottlenecks of Master/Slave configurations. This mode is called “Direct Port Access (DPA)” and requires enhanced software and drivers. The MS_DA input selects between Master/Slave mode (when HIGH) and DPA mode (when LOW). The SATA interface on the GD31244 supports four independent SATA ports, but may also be set up to emulate IDE Master/Slave (M/S or PCI IDE mode). IDE M/S emulation is included primarily for debugging purposes. Four 1.5 Gb/s Serial ATA ports are located on the GD31244 to support point-to-point connectivity to disk drives, CD ROMs, DVD ROMs or any other Serial ATA target device. Each port is compliant with the “Serial ATA / High Speed Serialized AT Attachment” specification, Rev. 1.0, August 29, 2001. High speed differential duplex serial lines send 8b/10b encoded data to and from the GD31244 and the target at a maximum data rate of 1.5 Gb/s (150 MB/s). Copies of the targets’ Task File Registers are maintained on the GD31244 and transferred as needed to the target. The GD31244 in M/S mode is software compatible with all existing operating systems that support ATA devices; however, performance and reliability are improved since all data is CRC checked.

As shown in [Figure 2](#), the SATA Unit implements four SATA ports. Each SATA port connects point-to-point to a SATA device such as a hard drive device using a four-wire serial link. Each SATA port supports the following features:

- 1 KB transmit/receive FIFO
- DMA Engine with scatter/gather capability
- The SATA Unit supports two operating modes:
 - PCI IDE (M/S) Mode
 - Direct Port Access Mode

In M/S mode, SATA ports 1 and 2 are used to emulate Master/Slave (M/S) operation for the Primary IDE Channel. Similarly, SATA ports 3 and 4 are used to emulate M/S operation for the Secondary IDE Channel. These ports are mapped in I/O Space/

In Direct Port Access Mode, each SATA port operates independently and all four SATA ports are memory-mapped contiguously using one base address register.

Figure 2. Serial ATA Unit Block Diagram

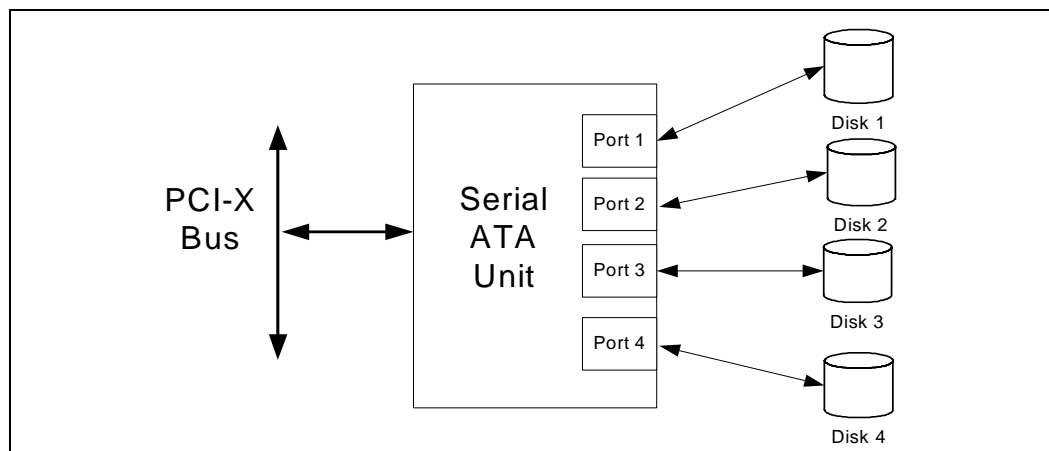

The GD31244 controller allows PCI masters on the PCI bus to initiate transactions to the SATA Unit ports and allows the SATA port DMAs to initiate transactions to the PCI bus. In M/S mode, the SATA Unit registers are mapped in the I/O space. Two channels (primary and secondary) are supported on the GD31244 controller. Each channel consists of four register blocks:

- Command
- Control
- DMA
- SATA Superset

PCI Base Address Register 0 points to the primary channel command block, Base Address Register 1 points to the primary channel control block, Base Address Register 2 points to the secondary channel command block, Base Address Register 3 points to the secondary channel control block, Base Address Register 4 points to both of the channel DMA register, and Base Address Register 5 defines the base I/O address for the SATA superset registers. Each channel supports its own DMA controller. The DMA moves data between memory and a device on the channel. There are two devices per channel for master/slave emulation. [Table 3](#) shows the PCI and PCI-X commands supported for both inbound and outbound transactions when in M/S Mode.

2.5 Modes of Operation

The programming interface for the GD31244 has 2 modes of operation: Master/Slave (M/S or PCI IDE) mode and Direct Port Access (DPA) mode.

2.5.1 Master/Slave Mode (or PCI IDE Mode)

Master/Slave (M/S) mode implements a PCI-native mode standard ATA controller with primary and secondary channels, each supporting a master and a slave mass storage device (4 SATA devices in total). M/S mode places the task file in different segments of I/O space and differentiates within each space between primary and secondary channels. Base Address Register 5 (BAR5) provides access to the SATA extended register set in I/O space.

2.5.2 Direct Port Access Mode

Direct Port Access (DPA) mode is a new mass storage sub-class that extends the standard task file interface to include expandable numbers of ports and advanced DMA capabilities. Standard PCI ATA controllers share the task file interface between the master and slave device, eliminating the ability to support simultaneous access between a master/slave pair. DPA allows the GD31244 to support unique task file interfaces between multiple SATA ports. DPA eliminates the parallel ATA master/slave protocol requirements. DPA access is geared for applications where high data bandwidth and performance are primary requirements. This mode allows for simultaneous access to each SATA port for true overlapped I/O capability. [Table 5](#) provides the primary features of the DPA mode interface.

Table 5. DPA Mode Interface Features

Features	Description
PCI up to 66 MHz or PCI-X up to 133 MHz	Required for bandwidth.
Independent port operation	Each SATA port can be controlled independently. Each port's registers are available at all time. This includes DMA registers.
One DMA Channel per SATA port	By having each SATA port support a DMA channel data to be transferred between device and memory independently of other devices. The DMA context can also be maintained.
Enhanced Interrupt Reporting	To report Serial ATA specific events: SError bits, First Party DMA receipt.

While utilizing DPA mode to accomplish an overlapped and independent I/O capability, the block, control block, DMA and SATA superset registers for each SATA port are available at all times. DMA context is unique to each port, allowing independent and simultaneous transfers between the host and each of the SATA ports.

2.5.3 Selecting DPA or M/S Mode

The GD31244 uses mode pin MS_DA to place the device in Master/Slave mode (when HIGH) or DPA mode (when LOW). This determination is made at power up so I/O and Memory can be configured correctly. Since a dynamic change in configuration memory and I/O mapping is not allowed, any mode change requires a power-on reset of the chip. As such, software control of this mode selection is not provided. The programming interface determines if the GD31244 is in M/S mode or DPA mode by reading the PCI base class and the subclass values defined herein. The subclass value for the DPA mode has been assigned by the PCI SIG and is 06h.

PCI/X bus operation is programmed through the configuration register set. This includes the required PCI register set and user-defined registers that configure split transaction behavior, message signaled interrupts and other advanced features. Mass storage devices are controlled through registers accessed via the BAR interface. Registers are divided into functional sets. These are the task file, bus master and extended register sets. Depending on the mode, these sets may appear at different addresses, have different bus widths or be extended to provide additional features. See the required M/S or DPA mode section as appropriate for the application. DPA mode utilizes a single BAR in memory space to access all register sets and organizes them by channel with an additional area for common registers.

Table 6. BAR Register usage in M/S and DPA Modes

BAR	DPA Mode	M/S Mode
0	32-bit device base address	I/O Task File Primary Command
1	32-bit device address extension (for 64-bit addresses)	I/O Task File Primary Control
2	Reserved	I/O Task File Secondary Command
3	Reserved	I/O Task File Secondary Control
4	Reserved	I/O Bus Master
5	Reserved	I/O Superset Registers

Serial ATA Direct Port Access (DPA) mode is selected when the MS_DA input is LOW. This mode provides an interface method for SATA host controllers that eliminates the parallel ATA M/S protocol requirements. DPA access is geared for applications where high data bandwidth and performance are primary requirements and software compatibility is not mandatory. This mode allows for simultaneous access to each SATA port for true overlapped I/O capability.

2.5.4 DPA Mode Port Initialization

In DPA mode, the GD31244 powers up with the serial ATA ports disabled. To enable each port, write 0 then 1 to bits 0:3 of each ports Serial Control Register. For example, to enable port 1: read BAR0 + 308h; AND the read value with FFFFFFF0h; write the result to BAR0 + 308h; “OR” the result with 000 0001h; write the result to BAR0 + 308h.

2.6 Serial EEPROM Interface

In add-in card applications, firmware may be downloaded to the system from a Serial EEPROM or Serial Flash ROM via the GD31244. This industry standard 4-pin interface known as SPI, allows any size of device to be connected to the GD31244 up to 128 KBytes. A typical firmware device is STMicroelectronics M25P10-A.

2.7 Extended Voltage Mode

The SATA voltages were designed primarily for a cable connection to the hard drives. In certain applications, such as NAS/SAN enclosures, the hard disk drives (HDD) are connected to a backplane, not a cable (typically in desktop systems). Due to the frequency of the SATA interface, the backplane creates a significant attenuation of the SATA signals. In an effort to simplify system designs, the GD31244 offers an extended voltage range to help alleviate this issue. This extended voltage range allows standard SATA HDD to be used with SATA backplanes. The firmware may be placed into the External Voltage Mode by setting bit 14 in PHY Configuration Register Address 140H to 1. This forces the firmware to operate with this extended voltage range.

Table 7. Normal Voltage Mode

Parameter	Description	Minimum	Maximum	Units
OUT	TX output differential peak-to-peak voltage swing	400	600	mVp-p
IN	RX input differential peak-to-peak voltage swing	325	600	mVp-p

Table 8. Extended Voltage Mode

Parameter	Description	Minimum	Maximum	Units
OUT	TX output differential peak-to-peak voltage swing	800	2000	mVp-p
IN	RX input differential peak-to-peak voltage swing	175	2000	

2.8 ACTIVITY LEDs

Serial ATA interfaces on disk drives do not include the traditional ATA output which drives an LED to indicate that the drive is active. The GD31244 compensates for this missing function by adding four LED outputs which sink 10 mA. In Master/Slave compatibility mode, LED0 goes LOW to turn on an Activity LED anytime there is activity on either Port 1 or Port 2. Likewise, LED1 goes LOW to turn on an Activity LED anytime there is activity on either Port 3 or Port 4. These two outputs may be wire “Or’d” together to use one LED for all four ports. If the GD31244 is configured in Direct Port Access mode (MS_DA is LOW), then each port is assigned its own LED as follows: Port 1 on LED0, Port 2 on LED1, Port 3 on SCLK and Port 4 on SDO. During EEPROM transfers, the LED function on SCLK and SDO is suspended. A buffer may be required if the LEDs are located off-board and an EEPROM is used. Through programmable registers, the GD31244 may be set up so that LED0 internally combines the status of all four ports for single LED use.

Figure 3. Common LED and Serial EEPROM Options

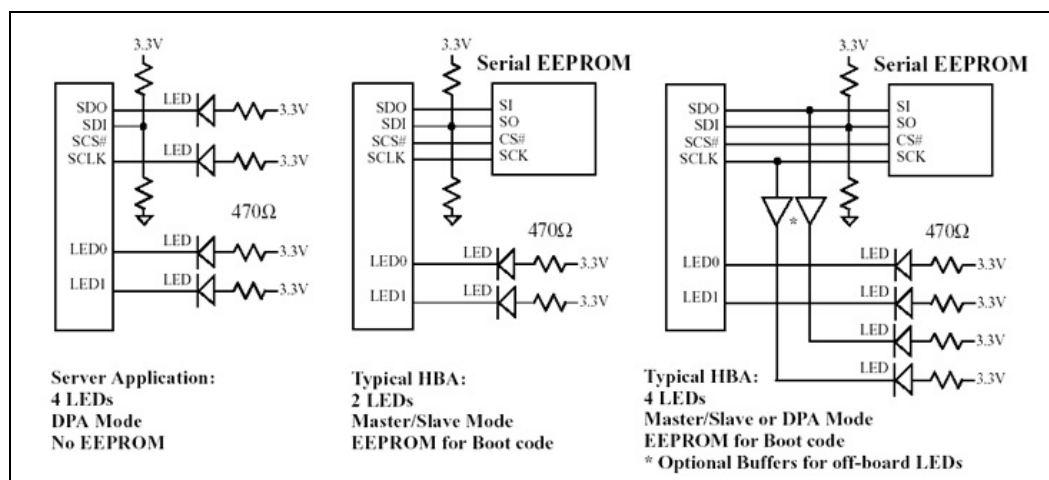

2.8.1 Reference Clock Generation

A 37.5 MHz reference clock with a +/- 100 ppm accuracy is required for proper operation of the GD31244. This can be generated from an external oscillator connected directly to the XI input. Optionally, a 37.5 MHz crystal may be connected between the XI and XO pins with a 20 pF capacitor from XI to ground and another from XO to ground. The crystal should have the following characteristics:

- Frequency: 37.5 MHz +/- 100 ppm
- Mode: Fundamental
- Type: “Parallel” resonant
- ESR: 30 Ohms maximum
- Load Capacitance: 20 pF
- Shunt Capacitance: 7 pF
- Drive Level: 500 mW maximum

Recommended Vendor/Part Number: Fox Electronics, Part number: 278-37.5-8 (This is an HC-49SD surface mountable package.) The crystal should be placed near the GD31244 and isolated from noisy circuits as much as possible.

2.9 High-End Storage Features

The GD31244 is well suited for high-end storage applications using Serial ATA drives. The Serial ATA Direct Port Access mode described above allows the host CPU to initiate overlapping operations to all four drives. Another feature is a “wide-swing mode” on the four transmitter outputs which provides approximately double the amplitude of normal operation. This increase differential voltage swing is useful in connecting to Serial ATA devices over backplanes or between systems.

2.10 JTAG Interface

An IEEE 1149.1 compatible JTAG interface and boundary scan functionality is provided to assist onboard testing of the device. GD31244

Serial EEPROM

3

The GD31244 is software compatible with all existing operating systems which support parallel ATA devices. However, the additional functions offered by the GD31244 require OS-specific code to take advantage of these beneficial functions. The code for initializing the system and booting drives will normally be located within the BIOS of the Host system or with an expansion ROM on the Host Bus Adapter card. A Serial EEPROM may be optionally connected to the GD31244 to store this code which will be downloaded and executed by the host system during initialization. Applications not requiring a downloadable program do not require the Serial EEPROM. The program should be downloaded into system RAM and executed there. Execution from the EEPROM should not be attempted. Details on expansion ROM operation and initialization may be found in the PCI 2.2 specification, Section 6.3.

The Intel GD31244 contains a four pin, Serial Peripheral Interface (SPI) to connect to an optional Serial EEPROM to store a downloadable program. At power-up, the GD31244 hardware automatically detects whether the EEPROM is present and indicates to this status to the Host System during initialization.

This SPI interface was designed for compatibility with an ST Microelectronics* M25P10-A or Atmel* AT25F1024 device with 131,072 Bytes of memory or an equivalent device. For the purposes of understanding Serial EEPROM operation, refer to the Datasheet for the ST Microelectronics documents, M25P10-A (dated February 2002) and Application Note (AN-1511 *Ensuring Compatibility Between M25P10 to M25P10-A and M25P05 to M25P05-A in Your Application*, dated February 2002) and the datasheet for the Atmel AT25F1024 (revision 1440G, dated February, 2002). The basic connection is shown in Figure 4.

Figure 4. Serial EEPROM Interface

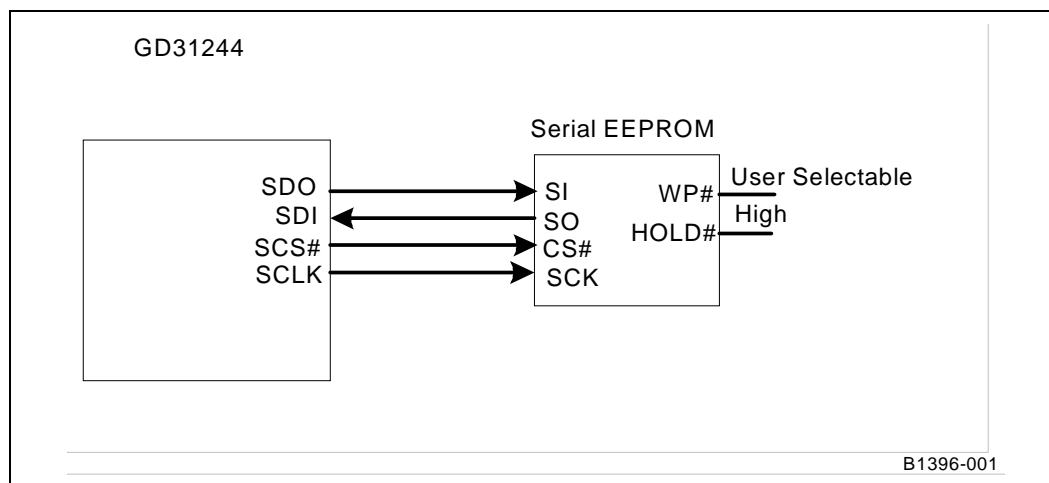

Note: The SDI, SDO and SCLK pins have multiple functions and may require additional functionality as presented in Table 9. WP# is not documented here. Refer to the vendors' datasheet.

Table 9. Serial EEPROM Interface Pins

Name	Description
SDI	INPUT - LVTTTL with Pull Up: Connects to the serial data output (SO) of the Serial EEPROM. Data is shifted out of the EEPROM on the falling edge of SCLK. Customers are recommended to add pads for both a pull-up and a pull-down resistor for possible use in the future.
SDO	OUTPUT - LVTTTL: Connects to the serial data input (SI) of the Serial EEPROM. Data is latched into the Serial EEPROM on the rising edge of SCLK. This is also the activity output for Channel 3 when all four LEDs are activated (active LOW).
SCLK	OUTPUT - LVTTTL: Connects to the clock input (SCK) of the Serial EEPROM. This is also the activity LED output for Channel 2 when all four LEDs are activated (active LOW).
SCS#	OUTPUT - LVTTTL with Pull Up: Connects to the chip select input (CS#) of the Serial EEPROM.

The GD31244 is a Master SPI device which outputs three signals (SCS#, SCLK and SDO) and inputs one signal (SDI). Only one external device is supported. The SCLK is derived from the PCI/PCI-X bus CLK signal as presented in Table 10. The GD31244 behaves as if the SPI modes are CPOL=0 and CPHA=0.

Table 10. SCLK Frequency

PCI-X Speed	SCLK	Period	Divider
PCI 33 MHz	8.25 MHz	121 nsec	4
PCI-X 66 MHz	16.5 MHz	60.6 nsec	4
PCI-X 100 MHz	12.5 MHz	80 nsec	8
PCI-X 133 MHz	16.625 MHz	60.2 nsec	8

The Serial EEPROM implements the nine commands presented in Table 11. These commands are supported through the GD31244, either through the PCI Configuration space (offsets 90h and 94h) or the memory interface.

Table 11. Serial EEPROM Commands

Command Name	Op_Code	Access	Operation
WRSR	01h - 0000 0001	PCI Config	Write Status Register
PROGRAM	02h - 0000 0010	Memory	Program Data into Memory Array
READ	03h - 0000 0011	Memory	Read Data from Memory Array
WRDI	04h - 0000 0100	PCI Config	Reset Write Enable Latch
RDSR	05h - 0000 0101	PCI Config	Read Status Register
WREN	06h - 0000 0110	PCI Config	Set Write Enable Latch
RDID	15h - 0001 0101	PCI Config	Read Manufacturer and Product ID
SECTOR ERASE	52h - 0101 0010	PCI Config	Erase One Sector in Memory Array
CHIP ERASE	62h - 0110 0010	PCI Config	Erase the entire Memory Array

3.1 Write Status Register (WRSR) Command

The WRSR command allows the user to control three bits within the EEPROM status register relating to write protection: WPEN, BP1 and BP0. The EEPROM is divided into four sectors that may be selectively write protected sectors where the top quarter (1/4), top half (1/2), or all of the memory sectors may be protected (locked out) from write. The AT25F512 is divided into two sectors where all of the memory sectors may be protected (locked out) from write. Any of the locked-out sectors will therefore be READ only. The locked-out sector and the corresponding status register control bits are presented in Table 12.

Table 12. Block Write Protect Bits

Level	Status Bit Registers		AT25F512		AT25F1024	
	BP1	BP0	Array Addresses Locked Out	Locked-out Sectors	Array Addresses Locked Out	Locked-out Sectors
0	0	0	None	None	None	None
1 (1/4)	0	1			018000 - 01FFFF	Sector 4
2 (1/2)	1	0			010000 - 01FFFF	Sector 3, 4
3 (All)	1	1	000000 - 00FFFF	All sectors (1-2)	000000 - 01FFFF	All sectors (1-4)

The three bits, BP0, BP1, and WPEN, are nonvolatile cells that have the same properties and functions as the regular memory cells (e.g., WREN, t WC, RDSR).

The WRSR command also allows the user to enable or disable the Write Protect (WP) pin through the use of the Write Protect Enable (WPEN) bit. Hardware write protection is enabled when the WP pin is low and the WPEN bit is 1. Hardware write protection is disabled when either the WP pin is high or the WPEN bit is 0. When the device is hardware write protected, writes to the Status Register, including the Block Protect bits and the WPEN bit, and the locked-out sectors in the memory array are disabled. Write is only allowed to sectors of the memory which are not locked out. The WRSR command is self-timed to automatically erase and program BP0, BP1, and WPEN bits. In order to write the status register, the device must first be write enabled through the WREN command. Then, the command and data for the three bits are entered. During the internal write cycle, all commands will be ignored except RDSR commands. The AT25F512/1024 will automatically return to write disable state at the completion of the WRSR cycle. The WRSR operation is shown in Figure 5.

Note: When the WPEN bit is hardware write protected, it cannot be changed back to 0, as long as the WP pin is held low.

Figure 5. Write Status Register (WRSR) Operation

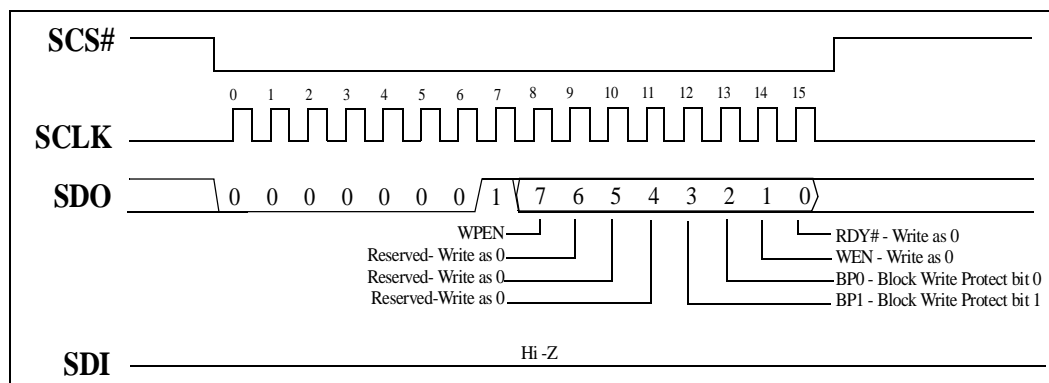

3.1.1 PROGRAM Command

In order to program the EEPROM, two separate commands must be executed. Prior to each PROGRAM command, the device must be write enabled through the WREN command. The PROGRAM command may then be executed. Also, the address of the memory location(s) to be programmed must be outside the protected address field location selected by the Block Write Protection Level. During an internal self-timed programming cycle, all commands will be ignored except the RDSR command.

The READY bit (bit 0) in the status register of the EEPROM may be determined by initiating a RDSR command. When HIGH, the program cycle is still in progress. When LOW, the program cycle has ended. Only the RDSR command is enabled during the program cycle. Single PROGRAM command programs 1, 2 or 4 consecutive bytes within a page if it is not write protected. The starting byte should be word aligned if 16-bit and dword aligned if 32-bit. The data of all other bytes on the same page will remain unchanged. The same byte cannot be reprogrammed without erasing the whole sector first. The EEPROM will automatically return to the write disable state at the completion of the PROGRAM cycle. The write memory (PROGRAM) operation for four bytes is shown in Figure 6.

Note: When the device is not write enabled with a WREN command, the device will ignore the PROGRAM command and will return to the standby state, when SCS# is brought high. A new SCS# falling edge is required to re-initiate the serial communication.

Figure 6. Write Memory (PROGRAM) Operation, 4 Byte

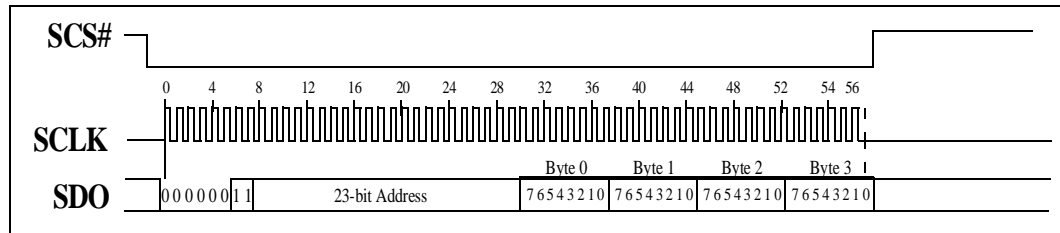

To issue a PROGRAM command:

1. Issue a WREN command as described elsewhere.
2. Issue a RDSR command to read that the RDY# bit is LOW and the WEN bit is HIGH in the EEPROM's Status Register to ensure that the EEPROM is ready to receive a write command.
3. When RDY# is not low, continue issuing RDSR commands until RDY# becomes low.
4. Issue a PROGRAM command by and 8-bit, 16-bit or 32-bit write to the ROM address.

3.1.2 READ Command

The EEPROM contains the downloadable programs needed in plug-in expansion card applications. Normally, after the card is configured, the Host system downloads the program from the EEPROM to RAM and executes from there.

Upon a ROM memory read, the GD31244 initiates an EEPROM READ operation at the memory location addressed by the PCI bus. The PCI/PCI-X memory address is translated into the 17-bit EEPROM memory address by the GD31244. Bits 23-17 of the EEPROM address are set to 0. Bits 16-0 of the EEPROM address are identical to the address on the PCI/PCI-X bus. The byte enables determine how many bytes will be read from the EEPROM (1, 2 or 4). The byte enables on ROM memory reads is presented in Table 13. The read memory (READ) operation for four bytes is shown in Figure 7.

Table 13. Byte Enables on ROM Memory Reads

C/BE#3	C/BE#2	C/BE#1	C/BE#0	Length (Bytes)	EEPROM A1 bit	EEPROM A0 bit
1	1	1	0	1	0	0
1	1	0	1	1	0	1
1	0	1	1	1	1	0
0	1	1	1	1	1	1
1	1	0	0	2	0	0
0	0	1	1	2	1	0
0	0	0	0	4	0	0

NOTE: The access must be word aligned if 16-bit and dword aligned if 32-bit.

Figure 7. Read Memory (READ) Operation, 4 Byte

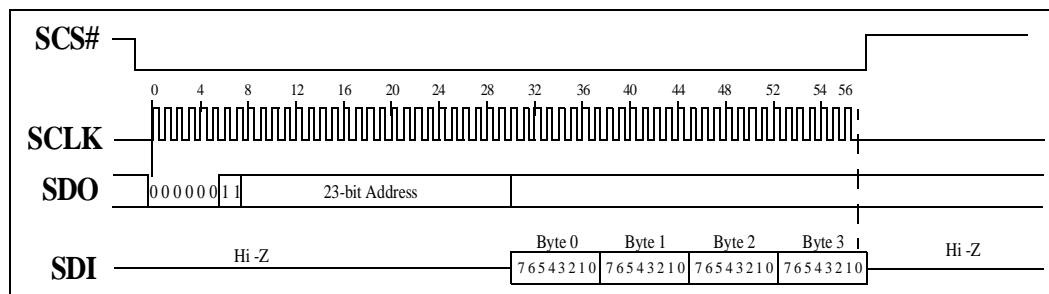

The READ command may only be issued when the EEPROM is ready to accept a new command. When the device is busy, it cannot accept any new commands except RDSR.

To issue a READ command:

1. Issue a RDSR command to read that the RDY# bit is LOW in the EEPROM's Status Register to ensure that the EEPROM is ready to receive a new command.
2. When RDY# is not LOW, continue issuing RDSR commands until RDY# becomes LOW.
3. Issue the READ command by performing a byte, word or double word read of the ROM at the desired address.

In PCs which are downloading the program stored in the EEPROM, the RDSR commands mentioned above will NOT be issued prior to a Read. This is acceptable during normal operation since the EEPROM will not be busy at this time.

When a READ command is issued while the EEPROM is busy, the EEPROM will return data which is all zero.

3.1.3 Write Disable (WRDI) Command

To protect the device against inadvertent writes, the WRDI command disables further write commands. The WRDI command is independent of the status of the WP pin. The write disable (WRDI) operation is shown in Figure 8.

Figure 8. Write Disable (WRDI) Operation

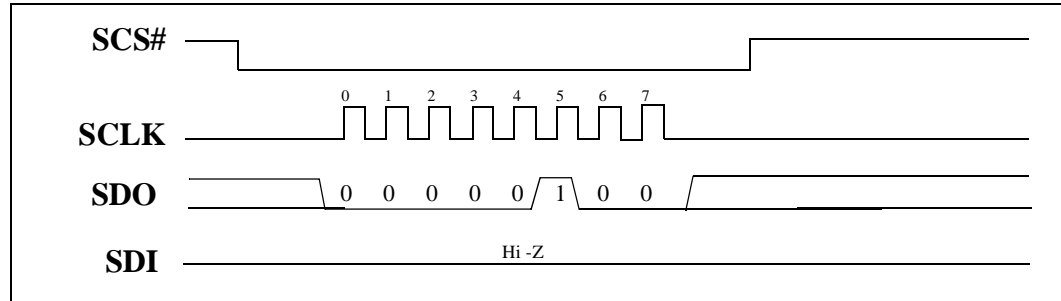

The WRDI command may only be issued when the EEPROM is ready to accept a new command. When the device is busy, it cannot accept any new commands except RDSR.

To issue a WRDI command:

1. Issue a RDSR command to read that the RDY# bit is LOW in the EEPROM's Status Register to ensure that the EEPROM is ready to receive a new command.
2. When RDY# is not LOW, continue issuing RDSR commands until RDY# becomes LOW.
3. Issue the WRDI command with an 8-bit write of 04h to the SPI Command Register at offset 90h.

3.1.4 Read Status Register (RDSR) Command

The RDSR command reads the EEPROM's status register. This is the most commonly issued command since the status register must be polled in order to determine that a previously issued command is complete and the device is ready to accept a new command. The real-time ready (RDY#) and write enable (WEN) status bits of the EEPROM may be determined by the RDSR command. Likewise, the write protect (WPEN) and block protect bits (BP1 and BP0) may also be read. These three bits are non-volatile memory cells which are set using the WRSR command. During internal write cycles, all other commands will be ignored except the RDSR command. The read status (RDSR) operation is shown in Figure 9. The status register format is presented in Table 14.

Figure 9. Read Status Register (RDSR) Operation

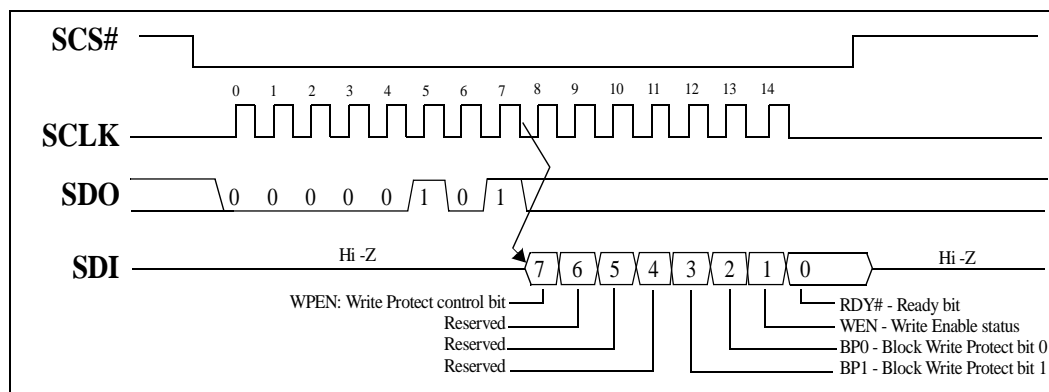

The RDSR command is unique in that it is always serviced by the EEPROM even if a previous command has yet to complete.

To issue a RDSR command:

1. Issue an 8-bit write of 05h to the SPI Command Register at offset 90h.
2. Read an 8-bit value from the SPI Data register at offset 94h.

Table 14. Status Register Format (Refer to Atmel® AT25F1024 Datasheet)

Bit	Name	Description
7	WPEN	When HIGH, allows override of the hardware write protect pin.
6-4	Reserved	These bits are LOW when the device is not in a write cycle. Write with '0'.
3 2	BP1 BP0	These two bits control which sectors of the chip are write protected: 00 - None 01 - Sector 4 10 - Sectors 3 & 4 11 - All sectors
1	WEN	When LOW, the device is write protected. When HIGH, the device is write enabled.
0	RDY#	When LOW, the device is READY. When HIGH, a write cycle is in progress.

3.1.5 Write Enable (WREN) Command

The EEPROM will power up in the write disable state. Any write command (PROGRAM, SECT_ERASE and CHIP_ERASE) must therefore be preceded by the WREN command. When the EEPROM is currently write enabled, the WEN bit in the Status Register will be HIGH. The write enable (WREN) operation is shown in Figure 10.

Figure 10. Write Enable (WREN) Operation

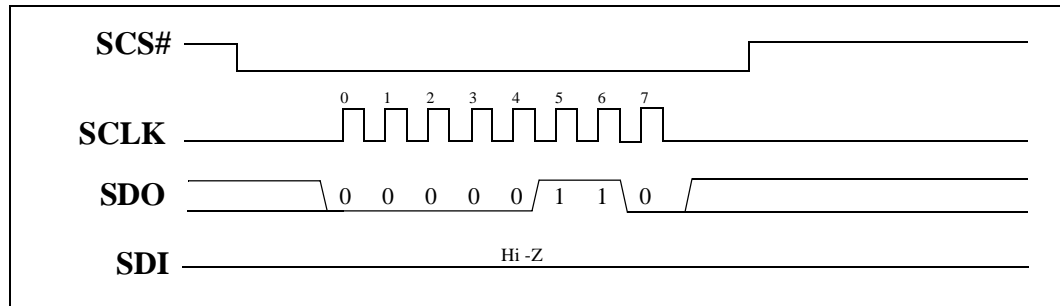

The WREN command may only be issued when the EEPROM is ready to accept a new command. When the device is busy, it cannot accept any new commands except RDSR. To issue a WREN command:

1. Issue a RDSR command to read that the RDY# bit is LOW in the EEPROM's Status Register to ensure that the EEPROM is ready to receive a new command.
2. When RDY# is not low, continue issuing RDSR commands until RDY# becomes low.
3. Issue a WREN command by an 8-bit write of 06h to the SPI Command Register at offset 90h.

3.1.6 Sector Erase (SECT_ERASE) Command

Before an EEPROM byte may be reprogrammed, the sector that contains the byte must be erased. In order to erase the EEPROM, two separate commands must be executed. First, the device must be write enabled through the WREN command, then the SECT_ERASE command may be executed. The SECT_ERASE command is internally controlled; it will automatically be timed to completion. During this time, all commands will be ignored, except RDSR command. The EEPROM will automatically return to the write disable state at the completion of the SECT_ERASE cycle.

The SECT_ERASE command erases every byte in the selected sector if the sector is not Write-Protected. The EEPROM Sector address (bits 16 & 15) is determined by two bits in the SPI Command Register at offset 91h: spi_sect_addr1 (mapped to bit 16) and spi_sect_addr0 (mapped to bit 15). These bits form the uppermost bits of the memory address and split the memory into the four sectors. Address bits 23-17 are LOW. The sector erase (SECT_ERASE) operation is shown in Figure 11.

Figure 11. Sector Erase (SECT_ERASE) Operation

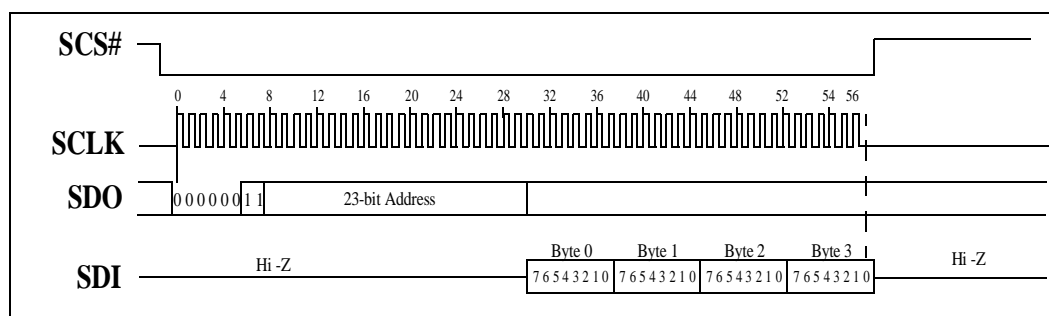

To issue a SECT_ERASE command:

1. Issue a WREN command as described in [Section 3.1.5](#).
2. Issue a RDSR command to read that the RDY# bit is LOW and the WEN bit is HIGH in the EEPROM's Status Register to ensure that the EEPROM is ready to receive a write command.
3. When RDY# is not low, continue issuing RDSR commands until RDY# becomes low.
4. Issue a SECT_ERASE command by an 8-bit write of 52h to the SPI Command Register at offset 90h.

3.1.7 CHIP_ERASE Command

As an alternative to the SECT_ERASE, the CHIP_ERASE command will erase every byte in all sectors that are not write protected. First, the device must be write enabled through the WREN command, then the CHIP_ERASE command may be executed. The CHIP_ERASE command is internally controlled; it will automatically be timed to completion. The CHIP_ERASE cycle time typically is 3.5 seconds.

During the internal erase cycle, all commands will be ignored except RDSR. The EEPROM will automatically return to the write disable state at the completion of the CHIP_ERASE cycle. The chip erase (CHIP_ERASE) operation is shown in Figure 12.

Figure 12. Chip Erase (CHIP_ERASE) Operation

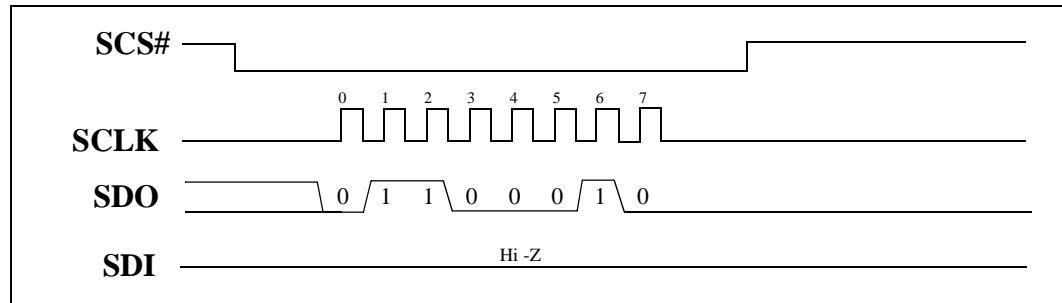

The CHIP_ERASE command may only be issued when the EEPROM is ready to accept a new command. When the device is busy, it cannot accept any new commands except RDSR. To issue a RDID command:

1. Issue a WREN command as described in Section 3.1.5.
2. Issue a RDSR command to read that the RDY# bit is LOW and the WEN bit is HIGH in the EEPROM's Status Register to ensure that the EEPROM is ready to receive a write command.
3. When RDY# is not low, continue issuing RDSR commands until RDY# becomes low.
4. Issue the CHIP_ERASE command with an 8-bit write of 62h to the SPI Command Register at offset 90h.

3.1.8 Read ID Register (RDID) Command

The RDID command allows the user to read the manufacturer and product ID of the EEPROM. The first byte after the command will be the manufacturer code (e.g., 1Fh = Atmel*), followed by the device code. The read ID register (RDID) operation is shown in Figure 13.

Figure 13. Read ID Register (RDID) Operation

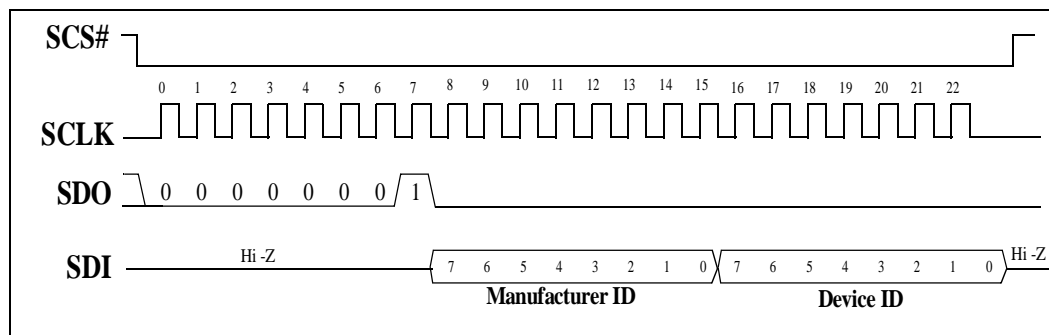

The RDID command may only be issued when the EEPROM is ready to accept a new command. When the device is busy, it cannot accept any new commands except RDSR. To issue a RDID command:

1. Issue a RDSR command to read that the RDY# bit is LOW in the EEPROM's Status Register to ensure that the EEPROM is ready to receive a new command.
2. When RDY# is not LOW, continue issuing RDSR commands until RDY# becomes LOW.
3. Issue the RDID command with an 8-bit write of 15h to the SPI Command Register at offset 90h.
4. Upon completion of the RDID command, the 8-bit Manufacturer's ID (1Fh for Atmel) will be located in bits 7:0 of the SPI Data Register (offset 94h) and the 8-bit Device ID (060h for AT25F1024) will be located in bits 15:8 of the SPI Data Register (offset 94h).

3.1.9 Serial EEPROM SPI Interface – Address 90h

3.1.9.1 Programming Details

This module implements a controller for interfacing to a serial EEPROM using the SPI (Serial Peripheral Interface) standard. The controller sits between a PCI core's application interface and the serial device. It contains a state machine that accesses the ROM 1, 2 or 4 times for each PCI transaction based on the byte enables.

Reads and writes are done through the PCI expansion port defined by CR30 in configuration space.

Reads from the serial device are very slow. The controller outputs a FIFO write signal to the PCI core upon completion of the read operation. Since the FIFO is empty until this time, the host read transaction will time-out and be retried by the PCI chipset until the controller writes the data into the FIFO. The design will fail if the host aborts retries or reorders transactions to the PCI target. A burst read transaction will be slowed down into a repetition of {retry, retry, ..., retry, read 1 data phase then disconnect without data}.

Writes to the serial device must be performed by a special device driver that polls the device status register to determine when the write is done. The next write may then be executed. Each write is composed of two operations. The host must issue a write enable command followed by a write data command of 1, 2 or 4 bytes. Burst writes are not allowed. Furthermore, the set of all write pairs must be preceded by one of the two erase commands. When the host attempts to write a subsequent data value before the first completes, the PCI core will complete the transaction and queue up the FIFO. The queue comes into play when the PCI bus write transaction period is less than the static target state machine cycle time and FIFO starts to fill up. To avoid overflowing the queue and causing the host to do retries, the serial EEPROM write driver should not issue a subsequent write until the current one is complete.

The host issues all commands except the read command through a register set in configuration space. The register set is composed of command, control and data registers. The host writes the command type to the command register after setting up the control and data registers as necessary. The controller starts when the command register is written. The host then polls the status register to determine when the command is complete. For read commands, except READ, the data register will contain the result when done.

Table 15. Write and Read Command Types

Command Type	inst [7:0]	ctrl [1:0]	data [15:0]	Description
Write				
WREN	06h	-	-	Write Enable
WRDI	04h	-	-	Write Disable
WRSR	01h	-	{XX, status [7:0]}	Write Status
PROGRAM †	02h	-	-	Write Data
SECT_ERASE	52h	a [16:15]	-	Erase 1/4 Chip
CHIP_ERASE	62h	-	-	Erase All Chip
Read				
RDSR	05h	-	{00h, status [7:0]}	Read Status
READ †	03h	-	-	Read Data
RDID	15h	-	601Fh	Read ID

† The PROGRAM and READ commands are done through the expansion ROM port of the PCI device. All other commands are done through the configuration register set.

The RDID value is for the Atmel* 25F1024 device. Other devices will have different values.

The legal values for the PCI byte enables on read and write operations are presented in Table 16.

Table 16. PCI Byte Enables on Read and Write Operations

byte_enables_n				count	a [1:0]
3	2	1	0		
1	1	1	0	1	0
1	1	0	1	1	1
1	0	1	1	1	2
0	1	1	1	1	3
1	1	0	0	2	0
0	0	1	1	2	2
0	0	0	0	4	0

3.1.9.2 SPI Command / Control / Status Register - Address 90h

3.1.9.2.1 SPI Command

Table 17. SPI Command

Master / Slave Mode and Direct Port Access Mode			
Bits	Type	Reset	Description
7:0	r/w	00h	Expansion ROM SPI interface command type. A write to this register initiates the command. The status register bit D0 must be polled to determine when the command is complete. 06h = WREN (Write Enable) 04h = WRDI (Write Disable) 01h = WRSR (Write Status) 02h = No action (SPI PROGRAM command) 52h = SECT_ERASE (Sector Erase) 62h = CHIP_ERASE (All Sector Erase) 05h = RDSR (Read Status) 03h = No action (SPI READ command) 15h = RDID (Read ID) Others = No action

3.1.9.2.2 SPI Control

Table 18. SPI Control

Master / Slave Mode and Direct Port Access Mode			
Bits	Type	Reset	Description
15:10	r/-	00h	Reserved.
9:8	r/w	00b	Sector address [1:0]. Selects one of four sectors for the sector erase command 52h.

3.1.9.2.3 SPI Status

Table 19. SPI Status

Master / Slave Mode and Direct Port Access Mode			
Bits	Type	Reset	Description
23:17	r/-	00h	Reserved.
16	r/-	0b	Command done. When HIGH, this indicates that the last command has been communicated to the serial device. It does not indicate the device is ready. The RDSR command must be issued to determine this.

3.1.9.3 SPI Data Register - Address 94h

Table 20. SPI Data Register - Address 94h

Master / Slave Mode and Direct Port Access Mode			
Bits	Type	Reset	Description
31:16	r/-	0	Reserved.
15:8	r/-	00h	Device ID for the RDID command.
7:0	r/-	00h	Manufacturer's ID for the RDID command.
7	r/w	00h	WPEN External WPB pin override
6			Reserved
5			Reserved
4			Reserved
3			BP1 Block Protect 1
2			BP0 Block Protect 0
1			WEN Write Enable
0			RDYn Ready Active LOW

This is a multifunction register used by three commands. For the RDID command, it is a read-only register with the Manufacturer's ID and Device ID in the upper and lower bytes respectively. For the WRSR/RDSR commands, the lower byte is a write/read register with the bit definitions presented in Table 20. The WPEN command is not applicable if the serial EEPROM device has its write protect pin WPB inactive high. Refer to the serial EEPROM device specification for how to use these bits.

3.1.10 Detection of the EEPROM at Power-Up

Immediately after power-on reset (an internal event based upon the power supply exceeding a minimum voltage), the GD31244 reads the EEPROM through the SPI interface to determine if an EEPROM is present.



This Page Left Intentionally Blank

Functional Blocks

4

4.1 Serial ATA

This section describes the Serial ATA (SATA) unit, including the operation modes and setup. Throughout this section, this unit is referred to as the SATA Unit or SU. The SATA Unit on 31244 supports four independent SATA ports, but may also be set up to emulate IDE master/slave.

With Parallel ATA (PATA), the controller and the device communicate using a 40-pin ribbon cable. The controller and device are connected through a parallel bus, which provides address, controls, and data signals. There are two register blocks on an ATA device:

Command Block Registers: The command block registers are used for normal data transfer requests.

Control Block Registers: The control block registers are used for device control such as software reset, and bist.

For example, the command block registers are used to issue commands to the device. The parallel interface also provides a DMA interface. Data may be exchanged between the controller and the device using either DMA or Programmed I/O (PIO). Refer to the *AT Attachment with Packet Interface-6 (ATA/ATAPI-6) Specification*.

SATA maintains the same programming interface. For example, the application still accesses the device with the same set of registers (Command Block Registers and Control Block Registers). Since the link between the controller and device is now serial, the device registers are now manipulated indirectly, requiring that the controller maintains a copy of all the device registers called the Shadow Register Block (SRB).

The serial bus defines a simple protocol for exchanging messages between the controller and the device. The serial protocol is transparent to the programmer. For example, the programmer does not have to be cognizant of how the serial protocol transmit and receive data. Refer to the *Serial ATA Specification*.

Information is exchanged between the controller and device over the serial bus using Frame Information Structures (FISs). The Serial ATA protocol defines a set of FIS:

- Register: Bidirectional
- DMA Activate: Device-to-Host
- DMA Setup: Bidirectional
- BIST Activate: Bidirectional
- Set Device Bits: Device-to-Host
- PIO Setup: Device-to-Host
- Data: Bidirectional

A FIS is a group of 32-bit words that may either be sent by the device or the controller. A FIS is packetized, by the Link layer, by inserting SOF and EOF fields before being sent over the serial bus by the PHY layer. Figure 14 shows the SATA protocol layers.

Transport Layer: This layer simply constructs FISs for transmission and decomposes received FISs. As an example, when the application layer (higher layer) wishes to access the device, it loads the appropriate value in the SRB (command last). Once the command is written, the Transport Layer converts the SRB content into appropriate FISs that is passed to the Link Layer. The opposite happens on the device. For example, the Transport Layer converts the received FISs from the Link Layer and passes it to the higher layer.

Link Layer: This layer simply transmits and receives frames. On the transmitter side, the Link Layer inserts frame envelope around the Transport Layer data. For example, the Link Layer inserts primitives like SOF, CRC, and EOF around the FISs from the Transport Layer. The opposite happens on the receiver side. For example, the Link Layer extracts the primitives from the frame and passes the FISs to the Transport Layer.

Physical Layer: This layer simply serialize the data from the link layer and deserialize the serial stream and passes the data to the Link Layer.

Figure 14. SATA Protocol Layers

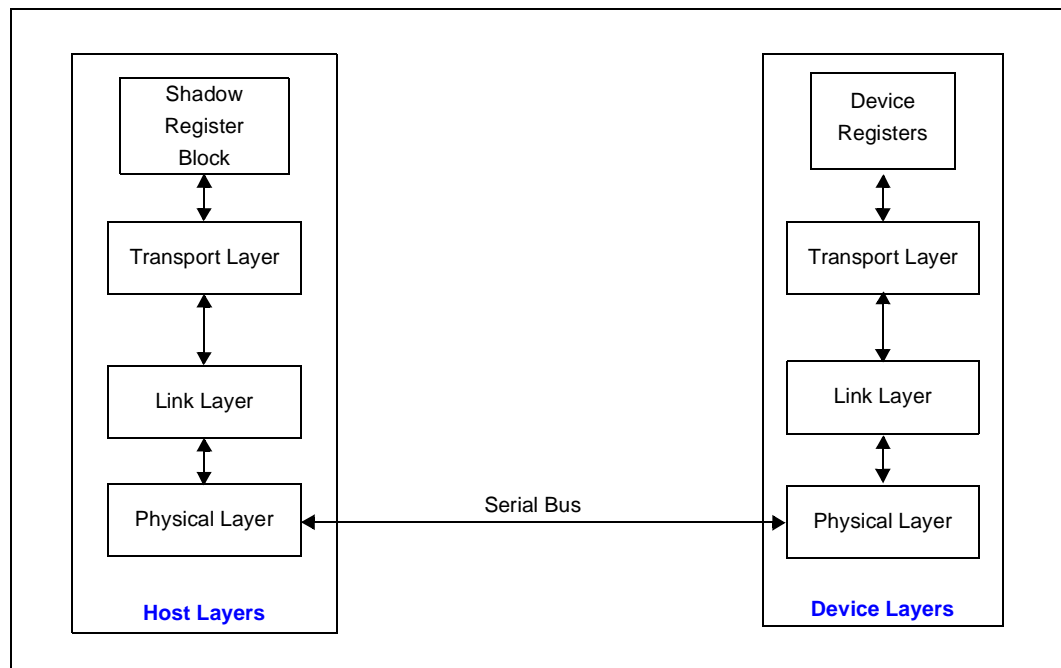

4.1.1 Out-of-Band Signaling

There are three Out-Of-Band (OOB) signals defined as part of the Analog Front End (AFE) layer of the PHY block:

- COMRESET
- COMINIT
- COMWAKE

These OOB signals are internal output from the receive AFE portion of the PHY and they are generated based on the detection of burst patterns of ALIGN primitives. Figure 15 shows a block diagram of the AFE cabling and the origin of the OOB signals.

Figure 15. Analog Front End (AFE) Cabling and OOB Signals

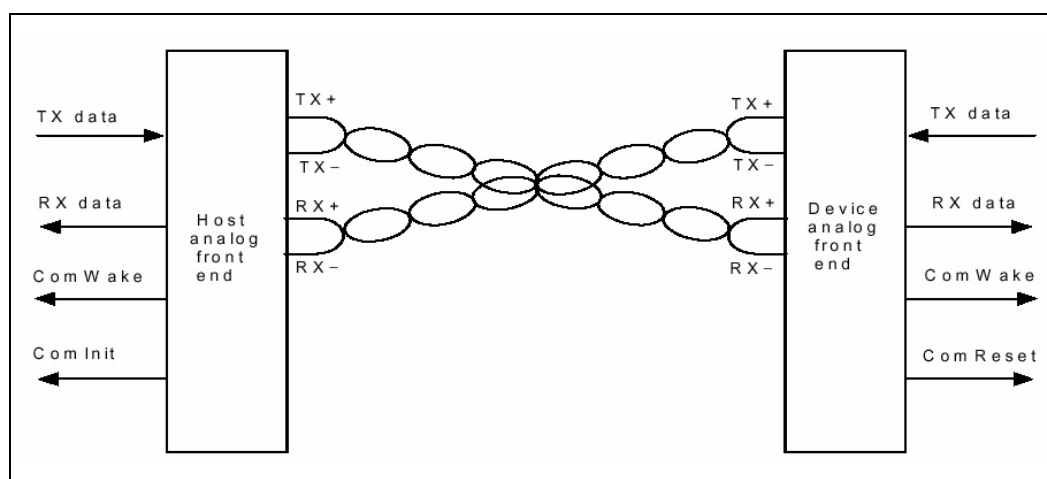

COMRESET and COMINIT have the same burst characteristics except that COMRESET originates from the host controller whereas COMINIT originates from the device. COMWAKE is different from COMRESET and COMINIT by having a different idle duration between bursts. Figure 16 shows the burst patterns timings.

Figure 16. OOB Signals Timings

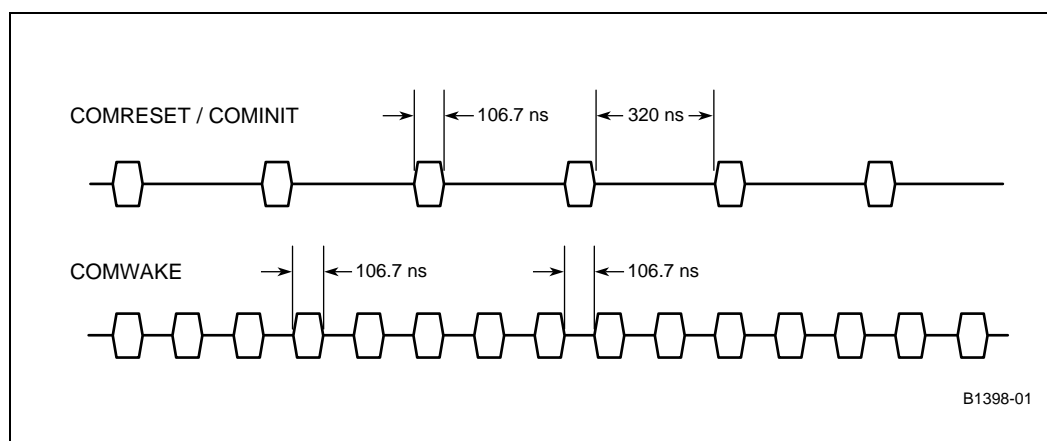

COMRESET is used by the controller to achieve two things:

- Initialize the serial bus to establish the communication link
- Hardware reset the device

Because of the nature of the serial bus, the serial bus has to be initialized before communication between the controller and the device may occur. The controller initiates a COMRESET on the serial bus to begin the initialization sequence. After the initialization sequence is completed, the communication link between the controller and the device is established and normal operation may begin. COMRESET is also used to cause a hardware reset of the device. Figure 17 shows a COMRESET sequence.

Figure 17. COMRESET Sequence

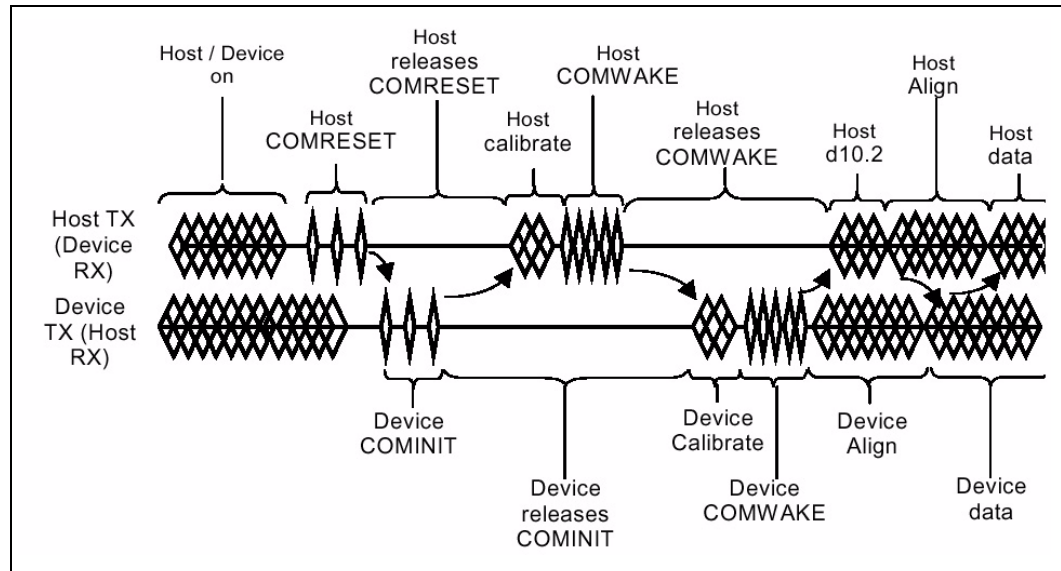

COMINIT always originates from the device. COMINIT is used by the device to initiate the initialization sequence of the serial bus, similar to what a COMRESET does. This is electrically identical to COMRESET except it originates from the device. After the initialization sequence is completed, the communication link between the controller and the device is established and normal operation may begin. Figure 18 shows a COMINIT sequence.

Figure 18. COMINIT Sequence

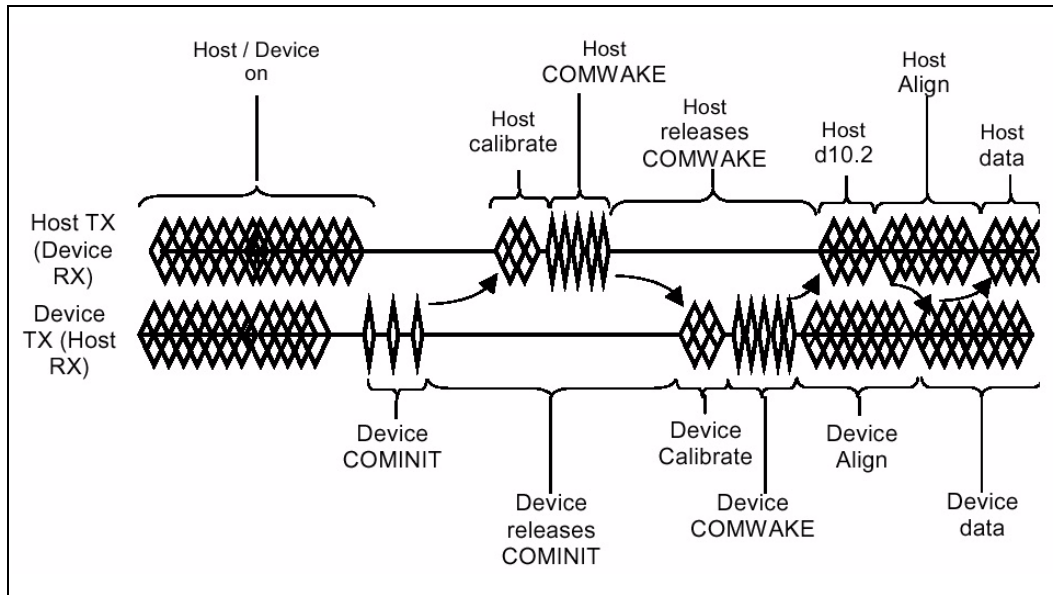

COMWAKE may originate from either the controller or the device. COMWAKE is used to bring the PHY out of a power-down state.

4.2 Operational Blocks

Each SATA port on the GD31244 controller contains the following blocks:

- Serial Engine
- Register Interface
- DMA Controller
- Programmed I/O (PIO) Interface

Figure 19. SATA Port Block Diagram

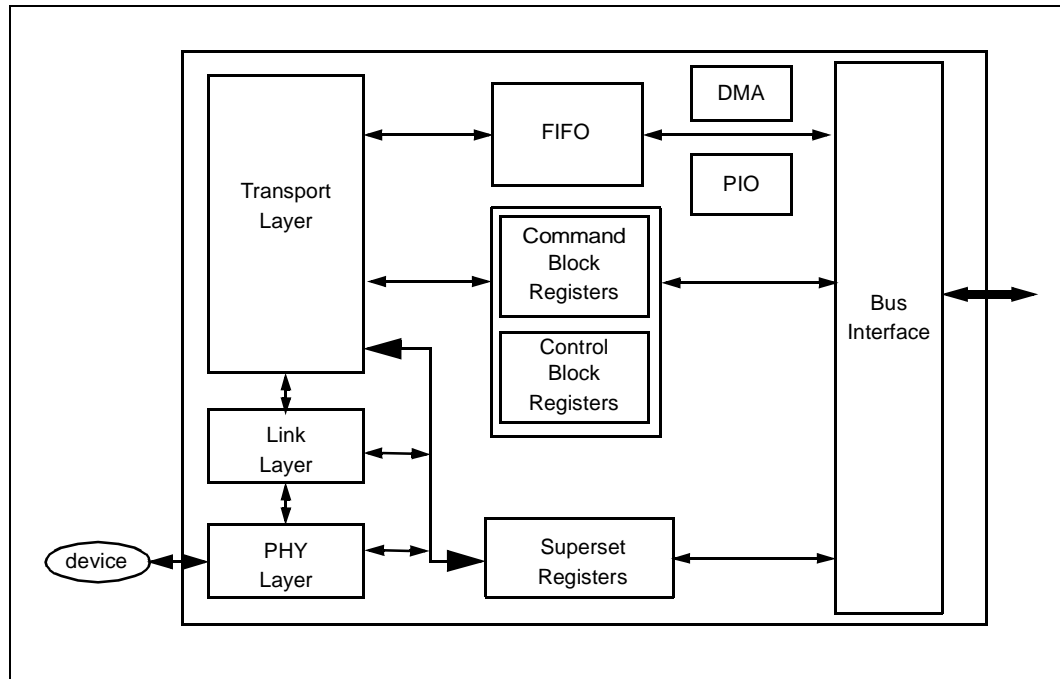

4.2.1 Serial Engine

The Serial Engine is transparent to the user. The Serial Engine consists of the three layers:

- Transport Layer
- Link Layer
- PHY Layer

Refer to the *Serial ATA Specification* for more details.

4.2.2 Register Interface

The GD31244 may be set up to operate in one of the following modes:

- PCI IDE Mode (legacy M/S)
- PCI Direct Port Access Mode

The register interface for each mode is described in Section , “The SATA Unit may be set up during system reset to execute in one of the following modes. Each mode provides a different programming interface. The DPA_MODE# external strap signal is sampled during the rising edge of PCI reset, to determine the operation mode.” on page 62.

4.2.3 DMA Controller

Several ATA commands use the DMA controller to transfer data. In DPA mode, each SATA port on the GD31244 controller supports its own DMA controller. This allows each SATA port to transfer data independent of each other. In PCI IDE mode, each channel (two SATA ports) supports one DMA controller. Data may be either received or transmitted to the SATA device using the DMA controller. The programming model provides a simple scatter/gather mechanism allowing large transfer blocks to be scattered to or gathered from memory. The DMA controller accesses system memory to read DMA descriptors. The DMA controller uses the DMA Descriptor Table Pointer to access the descriptors. The descriptor table contains a number of descriptors which describe areas of memory that are involved in the data transfer.

Figure 20 shows the structure of a descriptor table. The descriptor table is prepared and placed in memory by software. The descriptor table must be DWORD aligned and must not cross a 64 Kbyte boundary. Each descriptor is 8 bytes in length. The first DWORD specifies the WORD address of the data buffer. The lower two bytes of the second DWORD specifies the byte count of the data buffer. A value of zero in the byte count field implies a transfer count of 64 Kbytes, which is the maximum number of bytes that may be transferred per descriptor. Bit 7 of the upper byte of the second DWORD contains an EOT (End-Of-Transfer) bit. The EOT bit indicates when the last data buffer is reached. The GD31244 controller provides additional address registers to support PCI DAC cycles. For example, an Upper DMA Descriptor Table Pointer Register and an Upper DMA Address Register are defined. These registers allow the GD31244 controller to initiate PCI DAC cycles.

Note: The descriptor table must be aligned on a DWORD boundary, and must not cross a 64 Kbyte boundary.

Note: The address field (data buffer address) in the descriptor must be aligned on a WORD boundary. Furthermore, the data block must not cross a 64 Kbyte boundary.

Note: All the descriptors within a particular descriptor table share the same upper address register. For example, all the data buffers must be within the same 4 Gbyte page.

In PCI IDE mode, the primary channel DMA registers are as follows:

- “SU IDE Channel 0 DMA Command Register - SUICDCR0” on page 178
- “SU IDE Channel 0 DMA Status Register - SUICDSR0” on page 179
- “SU IDE Channel 0 DMA Descriptor Table Pointer Register - SUICDDTPR0” on page 180

The secondary channel DMA are as follows:

- “SU IDE Channel 1 DMA Command Register - SUICDCR1” on page 181
- “SU IDE Channel 1 DMA Status Register - SUICDSR1” on page 182
- “SU IDE Channel 1 DMA Descriptor Table Pointer Register - SUICDDTPR1” on page 183.

In DPA mode, the DMA register are as follows:

- “SU PCI DPA Upper DMA Descriptor Table Pointer Register - SUPDUDDTPR” on page 215
- “SU PCI DPA Upper DMA Data Buffer Pointer Register - SUPDUDDPR” on page 216
- “SU PCI DPA DMA Command Register - SUPDDCMDR” on page 217
- “SU PCI DPA DMA Status Register - SUPDDSR” on page 218
- “SU PCI DPA DMA Descriptor Table Pointer Register - SUPDDDTPR” on page 219

Figure 20. DMA Descriptor Table

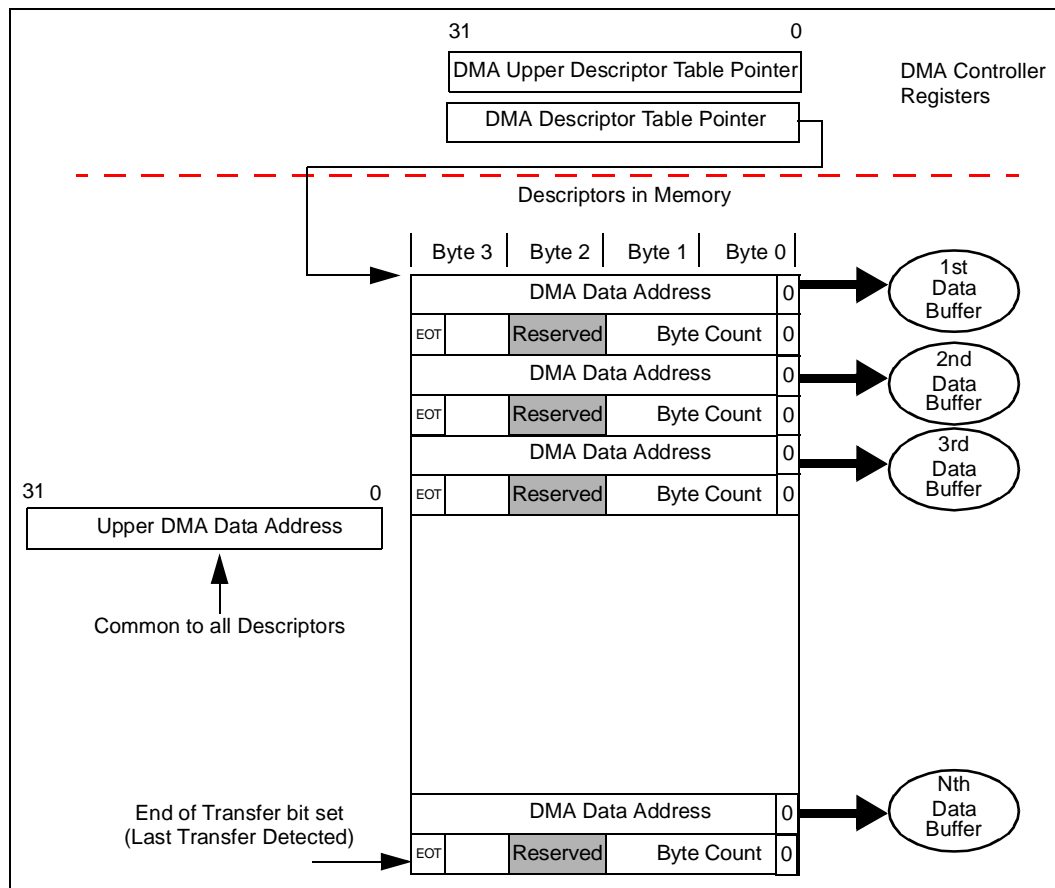

4.2.3.1 DMA Operation

To initiate a DMA transfer between memory and a device, the following steps are required:

- Software prepares a descriptor table in memory. Each descriptor is 8 bytes long and consists of an address pointer to the starting address and the byte count of the data buffer to be transferred. In a given descriptor table, two consecutive descriptors are offset by 8 bytes and are aligned on a 4-byte boundary.
- Software provides the starting address of the descriptor table by loading the DMA Descriptor Table Pointer Register of the DMA controller. The direction of the data transfer is specified by setting the Read/Write control bit in the DMA Command Register. Clear the interrupt bit and error bit in the Status Register.
- Software loads the appropriate DMA transfer command in the command block. Examples of such commands are:
 - READ DMA
 - WRITE DMA

The command is issued first by loading the command parameters and then writing the command register.

- Software engages the DMA engine by writing the Start bit in the DMA Command Register.
- The DMA engine transfers data to/from memory responding to the SATA port.
- At the end of the transfer the SATA port signals an interrupt
- In response to the interrupt, software resets the Start/Stop bit in the DMA Command Register. It then reads the DMA Status register and then the device status register to determine when the transfer completed successfully.

When a SATA port DMA controller makes a request on the PCI or PCI-X bus and the request is retried or disconnected, the current SATA port request will be re-attempted until the request is fully made. The other SATA port DMA will not be able to make requests on the PCI or PCI-X bus until the current request is either completed or gets a split response.

The DMA controller behaves differently in PCI IDE mode than in DPA mode when fetching the first DMA descriptor from memory. In PCI IDE mode, for a DMA WRITE command, the first descriptor fetch is triggered when the first DMA Activate FIS is received from the device. For a DMA READ command, the first descriptor fetch is triggered when the first Data FIS is received from the device. In DPA mode, the descriptor fetch is triggered when the Start bit in the DMA Command register is set regardless of DMA commands.

In both PCI IDE and DPA modes, the initial DMA data transfer is triggered under the same condition. For a DMA READ command (data is written to system memory), the receipt of the first Data FIS from the device triggers the data transfer. However, the DMA controller will have to wait for adequate data to be written into the FIFO, from the device, before it issues a write request to the bus master. For a DMA WRITE command (data is read from system memory), the receipt of the first DMA Activate FIS from the device (the same FIS that triggered fetching of the first descriptor) triggers the data transfer.

Note: During a DMA transfer, when a software reset is issued by writing the SRST bit in the Device Control register, the DMA controller for that particular port will stop the transfer by clearing the Active bit in the DMA Status register.

4.2.3.2 Data Synchronization

For READ DMA transactions, data coming from the SATA device is written by the serial engine into the FIFO. The DMA then reads the data from the FIFO and writes it into memory. The DMA and the serial engine operate independently. Therefore, data may remain in the FIFO well after the SATA device has indicated, through a Device-to-Host Register FIS, that it has completed the READ DMA transaction. For example, the DMA may be in the middle of flushing the FIFO. The Device-to-Host FIS contains an interrupt bit that is used to generate an interrupt. However, to ensure that all the data is transferred into memory, an interrupt is not generated until the FIFO has been emptied. This means that when a Register Device-to-Host FIS is received with the “I” bit set, and only after the FIFO has been emptied, that the SATA port sets the Interrupt Status Bit (bit 2) in the DMA Status Register and then generates an interrupt. [Table 21](#) describes the interrupt status bit and the DMA active bit states after a DMA transfer has been initiated. Refer to [Section 107, “SU IDE Channel 0 DMA Status Register - SUICDSR0”](#) on page 179 and [Section 110, “SU IDE Channel 1 DMA Status Register - SUICDSR1”](#) on page 182.

PCI IDE

Table 21. Interrupt /Activity Status Combinations

Bit 2 (Interrupt Status Bit)	Bit 0 (Active Bit)	Description
0 ₂	1 ₂	DMA transfer is in progress. No interrupt has been generated by the device.
1 ₂	0 ₂	Device generated an interrupt and the descriptor table has been exhausted. For example, the last descriptor has been processed. This is a normal completion where the size of the physical memory regions is equal to the device transfer size.
1 ₂	1 ₂	Device generated an interrupt. The DMA controller has not reached the end of the descriptor table. This is a valid completion case when the size of the physical memory regions is larger than the device transfer size.
0 ₂	0 ₂	Error condition. When the DMA controller Error bit is 1, the DMA controller encountered a problem transferring data to/from memory. Specifics of the error have to be determined using bus-specific information. When the Error bit is 0, the descriptor table specified a smaller transfer size than the programmed transfer size on the device.

Note: As described in [Table 21](#), for device read transactions the user may program the size of the physical regions to be larger than the device transfer size. However, during device write transactions the user must program the physical regions to be equal to the device transfer size. The GD31244 controller uses the DMA end-of-transfer status to complete the device write transaction.

4.2.3.3 DMA Error Conditions

When during a DMA transfer, a bus master error condition is encountered like a master abort, target abort, or a parity error is detected, the SATA port DMA will stop the transfer by clearing the Active bit in the DMA Status register and setting the Error bit in the DMA Status register. Note that the SATA port does not generate an interrupt when a bus master operation is aborted. Software will time out. The following is a list of bus master errors that may be encountered during DMA transactions. Note that not all bus master error conditions result in the DMA stopping. Refer to [Section 5.6, “PCI Bus Error Conditions” on page 83](#) for more details.

- Outbound Read Request Data Parity Errors
 - Immediate Data Transfer
 - Split Response Termination (PCI-X mode)
- Outbound Write Request Data Parity Errors
 - Non-MSI Transactions (Message Signaled Interrupts)
- Outbound Read Completion Address Parity Error
- Outbound Read Completions Attribute Parity Error
- Outbound Read Completion Data Parity Errors
- Split Completion Error Messages
- Master Abort for Outbound Read Requests
- Master Abort for Outbound Write Requests
- Target Abort for Outbound Read Requests
- Target ABort for Outbound Write Requests

When a requested device transfer (READ DMA or WRITE DMA) does not complete, the software driver will eventually time out. The software driver is then responsible for clearing the Start bit (bit 0) in the DMA Command register. Note that in this case the Error bit in the DMA Status register does not get set because there was no bus master error. An example of this type of error condition may occur when the DMA descriptors specified a smaller transfer size as the programmed transfer size in the device command. This causes the DMA to complete (DMA active bit cleared) while leaving the interrupt bit cleared. For example, an interrupt is not generated.

4.2.3.4 DMA Throughput

The PCI bus efficiency is improved, by allowing large data packets to be transferred. The 31244 controller allows up to 512-byte packets per burst transfer on the PCI bus. Table 22 and Table 23 show the PCI-X bus efficiency, based on various packet sizes for read and write transactions respectively. The tables clearly indicate how, by transferring larger data packets, more bandwidth is available on the PCI-X bus.

Table 22. PCI-X Bus Efficiency for Reads

Read Transaction Size (Bytes)	PCI-X Data Cycles	Read Overhead Cycles (Split Reads)	Bus Efficiency	Available Bandwidth (MB/Sec)		
				66 MHz	100 MHz	133 MHz
64	8	11	42%	222	336	446
128	16	11	59%	311	472	627
256	32	11	74%	390	592	787
512	64	11	85%	435	680	904
1024	128	11	92%	485	736	978

Table 23. PCI-X Bus Efficiency for Writes

Write Transaction Size (Bytes)	PCI-X Data Cycles	Write Overhead Cycles	Bus Efficiency	Available Bandwidth (MB/Sec)		
				66 MHz	100MHz	133MHz
64	8	4	66%	348	528	702
128	16	4	80%	422	640	851
256	32	4	88%	464	704	936
512	64	4	94%	496	752	1000
1024	128	4	96%	506	768	1021

In DPA Mode the 31244 controller provides one DMA engine per SATA port. Each SATA port also supports a 1 Kbyte FIFO. Each SATA port DMA operates independently and may transfer up to 512 bytes in one transfer.

Figure 21. DMA Arbitration

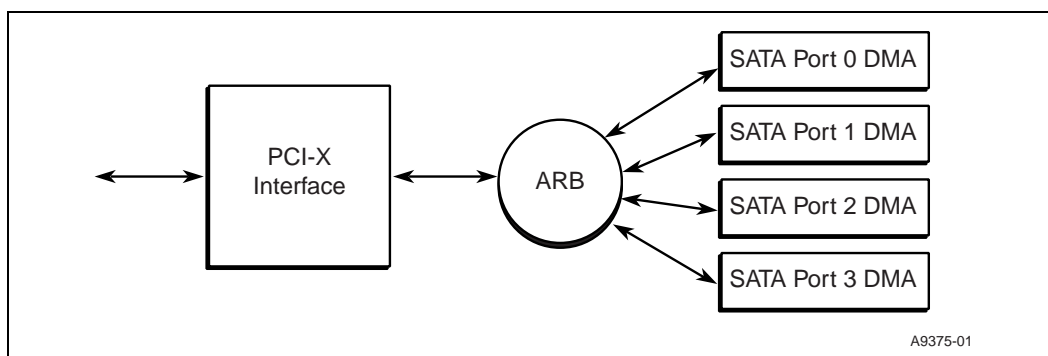

To accommodate multiple DMA engines to operate concurrently, the 31244 controller employs an internal arbitrator that controls the SATA ports DMA. The arbitrator allows the DMAs to post requests in a round-robin fashion, thus providing a fair algorithm to the SATA ports.

Table 24 and Table 25 provide the data transfer rate on the PCI-X bus, for a various number of ports, for read and write respectively. The transfer rates are based on 512-byte packets. Refer to Table 22 and Table 23 for PCI-X bandwidth numbers. Table 24 and Table 25 also show two 31244 controllers operating together, thus providing a total of eight ports. The numbers in Table 24 and Table 25 assume large sequential access across multiple drives.

Table 24. Read Transfer Rate on PCI-X Bus

PCI-X Speed (MHz) \ Number of Ports	Transfer Rate (MB/Sec)							
	1	2	3	4	5	6	7	8
66	140	280	420	435	435	435	435	435
100	140	280	420	560	680	680	680	680
133	140	280	420	560	700	840	904	904

NOTE: The SATA transfer rate is 140MB/s, instead of 150MB/s in order to account for bus protocol overhead.

Table 25. Write Transfer Rate on PCI-X Bus

PCI-X Speed (MHz) \ Number of Ports	Transfer Rate (MB/Sec)							
	1	2	3	4	5	6	7	8
66	140	280	420	496	496	496	496	496
100	140	280	420	560	700	752	752	752
133	140	280	420	560	700	840	1000	1000

NOTE: The SATA transfer rate is 140MB/s, instead of 150MB/s in order to account for bus protocol overhead.

4.2.4 Programmed I/O (PIO)

PIO is an alternate way of transferring data instead of using the DMA Controller. Data is transferred by the host processor reading or writing the Data Port register of the Command Block. In the ATA standard, some commands may only use PIO to transfer data. For example, the IDENTIFY DEVICE command. During PIO reads, data is read from the Data Port register, essentially pulling data from the head of the receive FIFO, while the serial link is pushing incoming data from the serial link to the tail of the FIFO.

During PIO writes, data is pushed into the Data Port register. Data written to the Data Port register is placed at the tail of the speed matching transmit FIFO. The serial link pulls data to transmit from the head of the FIFO.

IDE devices are sector-based mass storage devices, which means that data is always transferred on sector boundaries, and therefore a sector is the smallest readable/writable unit. A sector count is specified as part of the ATA command issued to the device. The minimum sector count may be equal to one.

The ATA standard supports the following commands for PIO data transfers:

- READ SECTOR
- WRITE SECTOR
- READ MULTIPLE
- WRITE MULTIPLE

The READ SECTOR and READ MULTIPLE are used to read data from the device, whereas the WRITE SECTOR and WRITE MULTIPLE are used to write data to the device. The READ SECTOR and WRITE SECTOR commands allow data to be transferred one sector per interrupt. For example, during a READ SECTOR command, an interrupt is generated by the device to indicate that a sector of data is ready to be read. After the sector is read, a new interrupt is generated when the next sector is ready to be transferred and this process continues until the requested sector count is exhausted. The WRITE SECTOR command also is used to transfer one sector per interrupt. The READ MULTIPLE and WRITE MULTIPLE commands allow multiple sectors to be transferred per interrupt instead of one sector per interrupt like the READ SECTOR and WRITE SECTOR commands. Most IDE devices support this feature and provide a programmable register on the device, which the user may program using the SET FEATURES command to setup the desired number of sectors to transfer per interrupt.

In both conventional PCI and PCI-X mode, during PIO transfers the GD31244 controller will respond with a retry when data is not available in the FIFO during reads or when the FIFO is full during writes.

The SATA Unit may be set up during system reset to execute in one of the following modes. Each mode provides a different programming interface. The DPA_MODE# external strap signal is sampled during the rising edge of PCI reset, to determine the operation mode.

- PCI IDE Mode
- PCI Direct Port Access Mode

4.2.5 Serial ATA II Native Command Queuing

Serial ATA II Command Queuing enables a hard drive to accept multiple commands from the GD31244 controller and rearrange the completion order of those commands to maximize throughput. The major portion of the drive's command service time is seek and rotational delay for the drive head to land on the appropriate data to transfer. The drive can use rotational optimizations to select the next command to complete such that the major components of the service time, seek and rotational delay, are minimized. A major advantage to command queuing is that the command issue and completion overhead may be overlapped with the drive seek and rotational delay for a different command's data transfer. For example, while a new command is being issued to the drive, the drive may be seeking to locate the appropriate track on disk for data for a different command. In essence, the latency for issuing the new command is saved since it was overlapped with the seek for another command.

Serial ATA II Native Command Queuing provides an efficient and streamlined data transfer and status return mechanism. This performance and efficiency is achieved through features of the SATA II Native Command Queuing protocol that include race-free status return mechanism, interrupt aggregation, and First Party DMA.

4.2.5.1 Race-free Status Return Mechanism

Serial ATA II Native Command Queuing has a race-free status return mechanism that allows status to be returned on any command at any time. There is no handshake required with the host for the status return. The drive may issue command completions for multiple commands back-to-back or even at the same time.

The Serial ATA II Native Queuing definition utilizes the reserved 32-bit field in the Set Device Bits FIS to convey the pending status for each of up to 32 outstanding commands. The BSY bit in the Status register conveys only the device's readiness to receive another command, and does not convey the completion status of queued commands. The 32 reserved bits in the Set Device Bits FIS are handled as a 32-element array of active command bits (referred to as ACT bits), one for each possible outstanding command, and the array is bit significant such that bit "n" in the array corresponds to the pending status of the command with tag "n."

The SActive register is used to track completion status of queued commands. This register is part of the control, status and error superset registers defined in the Serial ATA specification. In GD31244 this register is known as the Set Device Bits FIS Register SUPDSDBR.

Before host driver software issues a queued command to the device, it sets the bit corresponding to the tag of the queued command it is about to issue. When the device completes a queued command, it clears the bit corresponding to the tag of the queued command in the SActive bits in the Set Device Bits FIS. When the GD31244 receives the Set Device Bits FIS from the device it will automatically clear the bit corresponding to the tag of the queued command in the Set Device Bits FIS Register SUPDSDBR (SActive register). Host driver software queries the SActive register to determine which commands are complete.

This mechanism of the host controller setting bits in the register and the device clearing bits in the register ensures that no race condition can occur.

These examples describe how the bit field relates to the status of queued commands:

- 1 in bit location 0 signifies that the command with tag 0 is still pending
- 1 in bit location 16 signifies that the command with tag 16 is still pending
- 0 in bit location 16 signifies that the command with tag 16 is complete (if the bit was previously set)

4.2.5.2 Interrupt Aggregation

Serial ATA II Native Command Queuing has a maximum of one interrupt per command. In actuality, the number of interrupts per command is less than one due to a feature called interrupt aggregation. If the drive completes multiple commands in a short time span, the individual interrupts for each command may be aggregated into one interrupt by the GD31244. In this case, the host software driver only sees one interrupt for multiple commands. In a highly queued workload this is a frequent occurrence since host software interrupt service latency may be long in comparison to the time between command completions.

4.2.5.3 First Party DMA (FPDMA)

Serial ATA II Native Command Queuing has a mechanism such that the drive can select the DMA context for a subsequent data transfer without host software intervention using the GD31244. This mechanism is called First Party DMA. The drive selects the DMA context by sending a DMA Setup FIS to the host controller specifying the tag of the command that the data transfer is for. The host controller will load the scatter/gather table pointer for that command (based on the tag value) into the DMA engine. Then the DMA transfer may proceed.

The Serial ATA II Native Queuing definition utilizes the reserved 32-bit field in the Set Device Bits FIS to convey the pending status for each of up to 32 outstanding commands. The BSY bit in the Status register conveys only the device's readiness to receive another command, and does not convey the completion status of queued commands. The 32 reserved bits in the Set Device Bits FIS are handled as a 32-element array of active command bits (referred to as ACT bits), one for each possible outstanding command, and the array is bit significant such that bit "n" in the array corresponds to the pending status of the command with tag "n."

Data returned by the device (or transferred to the device) for queued commands use the First Party DMA mechanism to cause the host controller to select the appropriate destination/source memory buffer for the transfer. The memory handle used for the buffer selection is the same as the tag that is associated with the command. For traditional desktop host controllers, the handle may be used to index into a vector of pointers to pre-constructed scatter/gather lists (often referred to as physical region descriptor tables or simply PRD tables) in order to establish the proper context in the host's DMA engine.

Status is returned by updating the 32-element bit array in the Set Device Bits FIS for successful completions. For failed commands, the device halts processing commands allowing host software or controller firmware to intervene and resolve the source of the failure before processing is again explicitly restarted. For more information on native command queueing, see *Serial ATA II: Extensions to Serial ATA 1.0*

Programming Interface

5

The GD31244 register set is composed of several functional groups, some of which appear at different addresses and in different spaces (configuration, I/O, memory) when used in PCI IDE mode or DPA mode. PCI IDE mode is a legacy mode that uses I/O space for backwards compatibility while DPA mode is a new design using memory space. In PCI IDE mode, PCI ATA specifications use 5 of the 6 available BAR windows for task file and DMA registers. The Superset registers use the last BAR (BAR5). All other registers use configuration space.

Besides the required PCI configuration register set, these include:

- the PCI/PCI-X core configuration
- the Serial Expansion ROM registers
- the common port registers
- assorted control registers

In DPA mode, all the (I/O space) registers to which the 6 BAR registers point are consolidated into a single contiguous (memory space) set of registers to which BAR0/1 points. In addition, several of the common port registers are moved from the PCI configuration space to the BAR0/1 defined space. As defined in the PCI Local Bus Specification, BAR0/1 are used to allow for a 64-bit memory address with BAR0 being the low order 32 bits and BAR1 being the high order 32 bits of the address. The GD31244 uses mode pin MS_DA to place the device in Master/Slave mode (when HIGH) or DPA mode (when LOW). This determination is made at power up so I/O and Memory can be configured correctly.

5.1 PCI IDE Mode

The SATA Unit supports both Native-PCI IDE modes. In this mode, the GD31244 conforms to the *PCI IDE Specification - Revision 1.0*. In PCI IDE mode, the following registers are available to the user and are mapped in the I/O space.

- Command Block Registers
- Control Block Registers
- DMA Registers

5.1.1 Native-PCI Mode

In Native-PCI IDE mode, the Command Block Registers and Control Block Registers are completely relocatable in the I/O space using the PCI Base Address Registers, [Section 5.10.2.11, “SU Base Address Register 0 - SUBAR0” on page 119](#), [Section 5.10.2.12, “SU Base Address Register 1 - SUBAR1” on page 120](#), [Section 5.10.2.13, “SU Base Address Register 2 - SUBAR2” on page 121](#), and [Section 5.10.2.14, “SU Base Address Register 3 - SUBAR3” on page 122](#). [Table 26](#) shows the Base Address Registers and how they are used.

Table 26. SATA Port Register Mapping in Native PCI IDE Mode

Configuration Space BAR Offset	Registers
10H	Primary Channel Command Block
14H	Primary Channel Control Block
18H	Secondary Channel Command Block
1CH	Secondary Channel Control Block
20H	Primary and Secondary Channel DMA Registers
24H	SATA Superset Registers

Figure 22 shows how the SATA port registers are mapped in native-PCI IDE mode. Note that the DMA Controller Registers for both channels are accessed using the Base Address Register at offset 20H.

Figure 22. SATA Unit Register Mapping in Native-PCI Mode

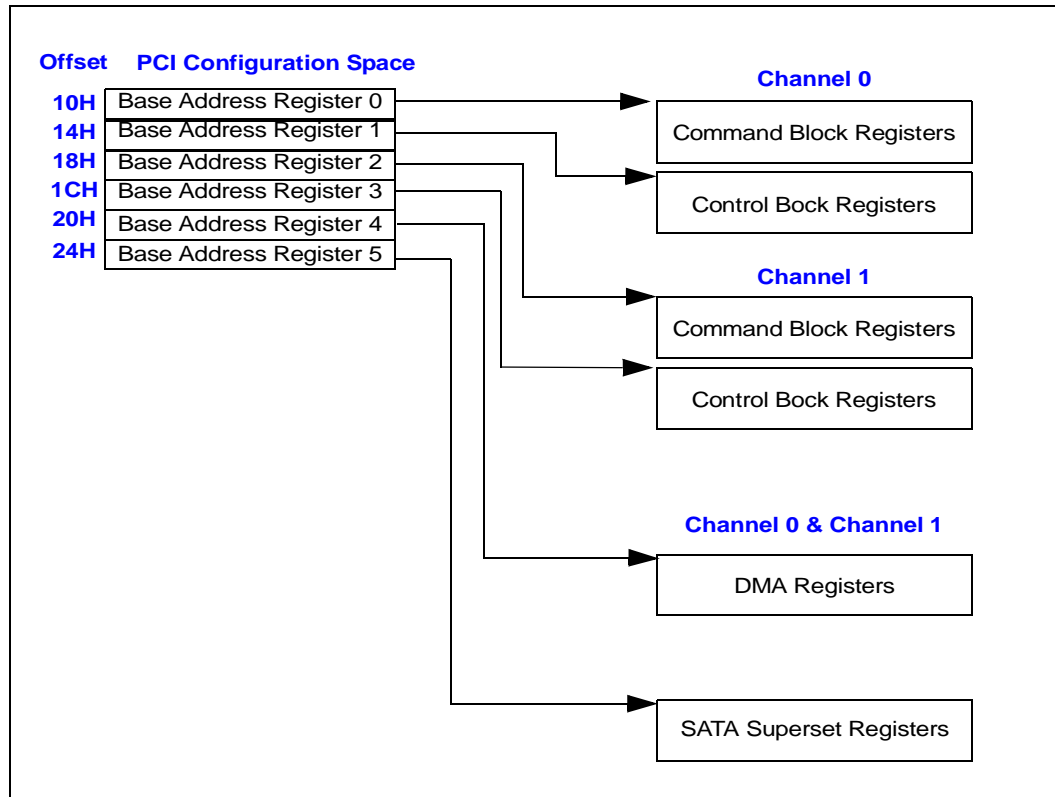

5.2 Direct Port Access Mode

This mode is specific to the 31244, it allows an external PCI master to control each SATA port independently. All four SATA port registers within the Serial ATA Unit are mapped contiguously in the PCI Memory Space using the PCI Base Address Registers, [Section 5.10.7.1, “SU PCI DPA Base Address Register 0 - SUPDBAR0”](#) on page 192 and [Section 5.10.7.2, “SU PCI DPA Upper Base Address Register 0 - SUPDUBAR0”](#) on page 193. Each SATA port register occupies 512 bytes of space. [Figure 23](#) shows the SATA ports to Base Address Register mapping. All the four SATA port registers within a Serial ATA Unit occupy 4 Kbytes of space. There is a common set of registers that are shared by all the SATA ports. Each SATA port consists of the following register blocks. The SATA ports registers are offset at 200H, 400H, 600H, and 800H for SATA Port 0, 1, 2, and 3 respectively. The Command Port register space starts at offset 000H.

- Common SATA Port Registers - shared by all SATA ports
- Command Block Registers
- Control Block Registers
- DMA registers
- Superset Registers

Figure 23. SATA Unit Register Mapping in Direct Port Access Mode

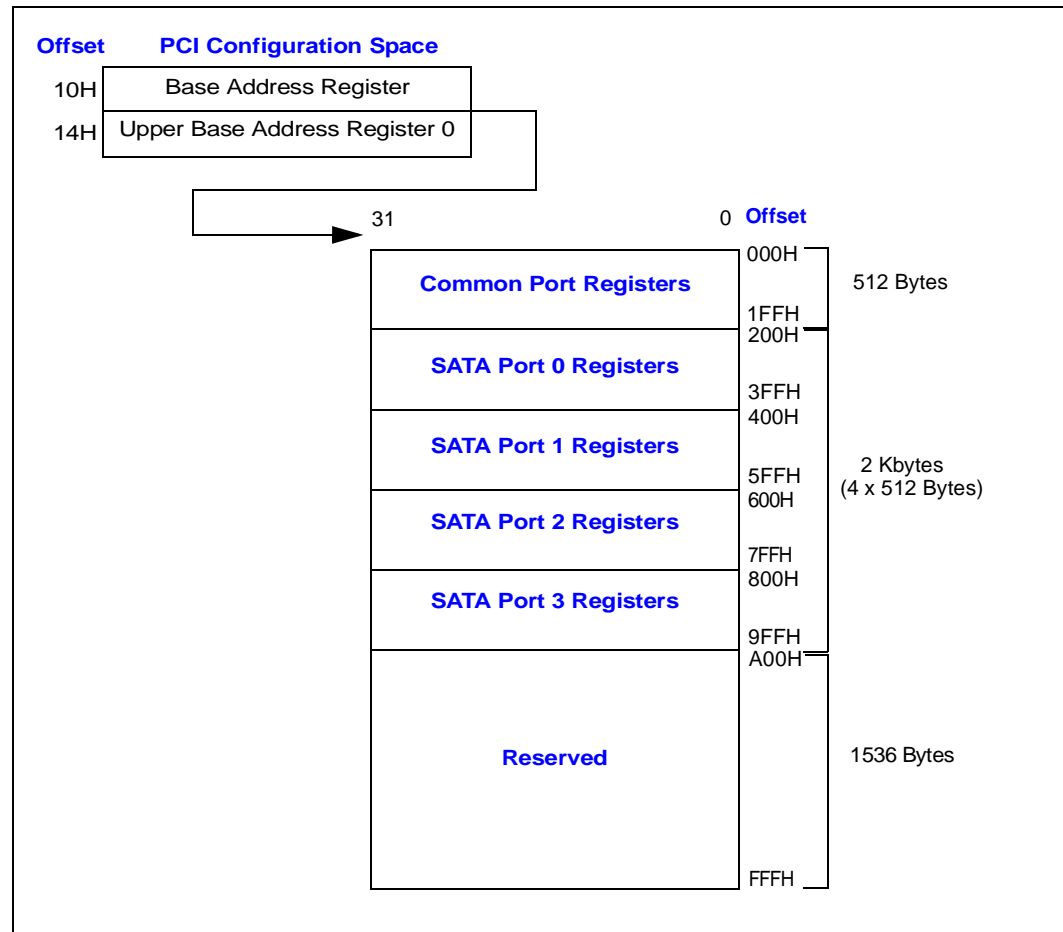

5.2.1 Common Serial ATA Port Registers

This section defines the registers that are common to all the Serial ATA ports for the SATA Unit. Figure 24 shows the registers mapping.

Figure 24. Common Serial ATA Port Registers

31	0	Offset
Serial ATA Unit Interrupt Pending Register		000H
Serial ATA Unit Interrupt Mask Register		004H
Reserved		008H - 1FFH

5.2.2 Command Block Registers

The Command Block Registers are used to issue ATA commands to the device. The Command Register must be written after the other registers in the Command Block are loaded, because the rest of the registers are parameters based on the command. The structure of the command block is shown in Figure 25. The Command Block Registers are memory-mapped when in the Direct Port Access mode. When in the PCI IDE mode, the Command Block Registers are I/O-mapped in the PCI I/O space. Figure 25 shows the Command Block Registers mapping when in the Direct Port Access mode (DPA) for SATA Port 0. Refer to Section , “The SATA Unit may be set up during system reset to execute in one of the following modes. Each mode provides a different programming interface. The DPA_MODE# external strap signal is sampled during the rising edge of PCI reset, to determine the operation mode.” on page 62 for further details on the mapping of these registers.

Figure 25. Command Block Registers for SATA Port 0

31	0	Offset
Data Port Register		200H
Features/Error Register		204H
Sector Count Register		208H
Sector Number Register		20CH
Cylinder Low Register		210H
Cylinder High Register		214H
Device/Head Register		218H
Command/Status Register		21CH

5.2.3 Control Block Registers

The Control Block Registers provide control and status of the device. Figure 26 shows the Control Block Register mapping. Refer to Section , “The SATA Unit may be set up during system reset to execute in one of the following modes. Each mode provides a different programming interface. The DPA_MODE# external strap signal is sampled during the rising edge of PCI reset, to determine the operation mode.” on page 62 for further details on the mapping when in the Direct Port Access mode (DPA) of the registers for SATA Port 0.

Figure 26. Control Block Registers for SATA Port 0

31	0	Offset
Reserved		220H
Reserved		224H
Device Control/Alternate Status Registers		228H
Reserved		22CH

5.2.4 DMA Controller Registers

The DMA Controller Registers provide control and status for the DMA Controller. Several ATA commands use the DMA Controller to transfer data between device and memory. Figure 27 shows the DMA Controller register mapping when in the Direct Port Access mode (DPA) for SATA Port 0. Refer to Section , “The SATA Unit may be set up during system reset to execute in one of the following modes. Each mode provides a different programming interface. The DPA_MODE# external strap signal is sampled during the rising edge of PCI reset, to determine the operation mode.” on page 62 for further details on the mapping of the registers.

Figure 27. DMA Controller Registers for SATA Port 0

31	0	Offset
DMA Control Register		260H
DMA Upper Descriptor Table Pointer		264H
DMA Upper Data Buffer Pointer		268H
Reserved		26CH - 26FH
DMA Command/Status Registers		270H
DMA Descriptor Table Pointer		274H

5.2.5 SATA Superset Registers

The SATA Superset Registers, define two sets of registers. These registers are specific to the *Serial ATA Specification*, hence superset.

The *Serial ATA Specification* defines an additional block of registers mapped separately and independently from the ATA Command Block Registers for additional status and error information and allow control of capabilities unique to Serial ATA. These registers referred to as the Serial ATA Status and Control Registers (SCRs) are organized as 16 contiguous 32-bit registers. The current specification defines three registers only, and the remaining thirteen are reserved for future implementation. The defined SCRs are as follows:

- SStatus Register
- SError Register
- SControl Register

The Serial ATA protocol also provides additional SATA specific commands. The Serial ATA defines two Frame Information Structures (FIS) that are not used by the current ATA Command set. However, these FISs may be used to enable new device capabilities.

- BIST Activate (Bidirectional)
- DMA Setup - Device to Host or Host to Device (Bidirectional)

Table 27 shows the SATA Interface Registers mapping when in the Direct Port Access mode for SATA Port 0. Refer to Section , “The SATA Unit may be set up during system reset to execute in one of the following modes. Each mode provides a different programming interface. The DPA_MODE# external strap signal is sampled during the rising edge of PCI reset, to determine the operation mode.” on page 62 for further details on the mapping of the registers based on the specific programming interface. When in PCI IDE mode, the super registers of a device on a given channel are selected using the DEV bit of the Device/Head register (bit 4). A channel (primary or secondary) is selected using bit 16 of the APT Control Register. Refer to Section 5.10.3.8, “SU IDE Device/Head Register - SUIDR” on page 173 and Section 5.10.2.30, “SU Extended Control and Status Register 0 - SUECSR0” on page 138. Also, when in PCI IDE mode, the superset registers are accessed using Base Address Register 5. Refer to Section 5.10.2.16, “SU Base Address Register 5 - SUBAR5” on page 124.

Note: The superset registers when in PCI IDE mode are accessed using SUBAR5 starting at offset 000H. For example, Table 27 shows the first register starting at offset 300H, 304H, 308H and so on in DPA mode. In PCI IDE mode, the registers start at offset 00H, 004H, 008H and so on.

Table 27. SATA Superset Registers for SATA Port 0 in DPA Mode

	31	0	Offset	
SCRs Registers		SU PCI DPA SATA SStatus Register - SUPDSSSR	300H	
		SU PCI DPA SATA SError Register - SUPDSSER	304H	
		SU PCI DPA SATA SControl Register - SUPDSSCR	308H	
		SU PCI DPA Set Device Bits Register - SUPDSDBR	30CH	
		Reserved	310H - 33FH	
BIST Registers		SU PCI DPA PHY Feature Register - SUPDPFR	340H	
		SU PCI DPA BIST FIS Control and Status Register - SUPDBFCSR	344H	
		SU PCI DPA BIST Errors Register - SUPDBER	348H	
		SU PCI DPA BIST Frames Register - SUPDBFR	34CH	
		SU PCI DPA Host BIST Data Low Register - SUPDHBDLR	350H	
		SU PCI DPA Host BIST Data High Register - SUPDHBDRH	354H	
		SU PCI DPA Device BIST Data Low Register - SUPDDBDLR	358H	
		SU PCI DPA Device BIST Data High Register - SUPDDBDRH	35CH	
DMA Setup Registers		SU PCI DPA Queuing Table Address Register Low - SUPDQTBARL	360H	
		SU PCI DPA Queuing Table Address Register High - SUPDQTBARH	364H	
		SU PCI DPA DMA Setup FIS Control and Status Register - SUPDDSFCSR	368H	
		SU PCI DPA Host DMA Buffer Identifier Low Register - SUPDHDBILR	36CH	
		SU PCI DPA Host DMA Buffer Identifier High Register - SUPDHDBIHR	370H	
		SU PCI DPA Host Reserved DWORD Register 0 - SUPDHRDR0	374H	
		SU PCI DPA Host DMA Buffer Offset Register - SUPDHDBOR	378H	
		SU PCI DPA Host DMA Transfer Count Register - SUPDHDTCR	37CH	
		SU PCI DPA Host Reserved DWORD Register 1- SUPDHRDR1	380H	
		SU PCI DPA Device DMA Buffer Identifier Low Register - SUPDDBILR	384H	
		SU PCI DPA Device DMA Buffer Identifier High Register - SUPDDBIHR	388H	
		SU PCI DPA Host Reserved DWORD Register 0 - SUPDHRDR0	38CH	
		SU PCI DPA Device DMA Buffer Offset Register - SUPDDBOR	390H	
		SU PCI DPA Device DMA Transfer Count Register - SUPDDTTCR	394H	
		SU PCI DPA Device Reserved DWORD Register 1 - SUPDDRDR1	398H	
	Reserved Route		Reserved	39CH
			Reserved	3A0H
		Reserved	3A4H	
		Reserved	3A8H	
		Reserved	3ACH	
		Reserved	3B0H	
		Reserved	3B4H	
		Reserved	3B8H	
		Reserved	3BCH	
		Reserved	3C0H	
		Reserved	3C4H	
		Reserved	3C8H	
		Test Register 0	3CCH	
		Test Register 1	3D0H	
		Reserved	3D4H - 3FFH	

NOTE: The Offsets mentioned above, only indicate Port 0. To view the other three Port offset values, see each specific register.

5.3 ATA Command Processing

A command is issued to a device by writing the Command Block Registers. The command register should be written last, after the rest of the registers are written. The rest of the registers, except for the data port register, are parameters based on the command. Writing the command register initiates a transfer of a Register FIS from the controller to the device.

Commands may be categorized as data and non-data commands. Non-data commands do not involve data transfer. Examples of such commands are:

- SEEK
- IDLE
- SLEEP
- NOP
- FLUSH CACHE
- STANDBY

Refer to the *ATA Attachment with Packet Interface-6 (ATA/ATAPI-6) Specification*. Data commands involve the transfer of one or more blocks of data. There are two classes of data commands. There are data commands that use the DMA protocol to transfer data and others that use the PIO protocol. Examples of PIO data commands are:

- READ BUFFER
- WRITE BUFFER
- READ SECTOR
- WRITE SECTOR

Examples of DMA data commands are:

- READ DMA
- WRITE DMA

For PIO commands, data is transferred by either reading or writing the Command Block Data Port Register.

An ATA device is addressed by using two methods:

CHS Cylinder/Head/Sector.

LBA Logical Block Addressing.

Disk assembly of a drive usually consists of a number of surfaces, each of which stores data on concentric circles called tracks. The tracks are further divided into sectors, which are the smallest readable/writable units. A sector is accessed by first positioning the read/write head above the proper track and then waits until the desired sector rotates underneath the head to read or write the data. Writing and reading the sector is done serially bit-by-bit.

A drive usually contains multiple disks, and both sides of the a disk may be utilized for storage. Each surface has its own read/write head although only one track may be written to or read at a given time. The heads are positioned collectively over the tracks. A set of tracks that may be accessed by the heads from a single position is a cylinder. A consequence of this organization is that every sector may be addressed by its Cylinder, Head, and Sector Numbers. This is referred to as the drive geometry.

In LBA mode, the drive presents itself as a continuous sequence of sectors or blocks which are addressed by their logical block number, like 0, 1, 2,...N-1, where N is the number of sectors on the drive. In this case the drive physical geometry (CHS) need not be known to the host. For example, the drive presents itself more or less like random memories are presented where an address is used to select a byte from an array of bytes, thus the actual topology of the memory bits need not be known by the user.

5.3.1 LBA Addressing in PCI IDE Mode

This section describes how the command block registers are utilized in 28-bit and 48-bit LBA addressing modes. The Device/Head register (bit 6) indicates whether a command is using CHS (Cylinder/Head/Sector) or LBA address format. When bit 6 of the Device/Head register is set, LBA address format is being used. Table 28 shows how the command block registers are utilized for 28-bit LBA addressing.

Table 28. 28-Bit LBA Address Bit Layout in PCI IDE Mode

Register \ LBA Bits	Register Bit Location							
	7	6	5	4	3	2	1	0
Sector Number / LBA Low	7	6	5	4	3	2	1	0
Cylinder Low / LBA Mid	15	14	13	12	11	10	9	8
Cylinder High / LBA High	23	22	21	20	19	18	17	16
Device/Head	N/A	LBA	N/A	DEV	27	26	25	24

Table 29 shows how the command block registers are utilized for 48-bit LBA addressing. To preserve the same ATA standard programming interface, the Sector Count, LBA Low, LBA Mid, and LBA High registers are kept as 8-bit registers. Instead, these registers are implemented as 8-bit ports to two-byte deep FIFOs. Note that the 8-bit port must always be written in pairs, otherwise proper functionality is not guaranteed. For example, a 16-bit value is loaded to any of these registers by performing two 8-bit writes. The three 16-bit registers, therefore, provides the 48-bit LBA address bits. The most recently written value to any of these registers is pushed into the lower byte position and the previous written value gets pushed into the upper byte position. As an example, when the value 17H is written to Cylinder Low/LBA Mid register followed by the value 68H to the same register, the value 17H first goes into LBA[15:8]. After the value 68H is written, the value 17H gets pushed into LBA[39:32] and the value 68H goes into LBA[15:8]. Table 30 summarizes the loading sequence.

Note: Note that the Device/Head register is not used to form a 48-bit LBA address. However, bits 0-3 of the Device/Head register must be set high.

Table 29. 48-Bit LBA Address Bit Layout

Register \ LBA Bits	Register Bit Location							
	7	6	5	4	3	2	1	0
Sector Number / LBA Low	31/7	30/6	29/5	28/4	27/3	26/2	25/1	24/0
Cylinder Low / LBA Mid	39/15	38/14	37/13	36/12	35/11	34/10	33/9	32/8
Cylinder High / LBA High	47/23	46/22	45/21	44/20	43/19	42/18	41/17	40/16
Device/Head	N/A	LBA	N/A	DEV	1	1	1	1

Table 30. 48-Bit Address Loading Sequence

Register	Most Recently Written	Previous Content
Sector Count	Sector Count[7:0]	Sector Count[15:8]
Sector Number / LBA Low	LBA[7:0]	LBA[31:24]
Cylinder Low / LBA Mid	LBA[15:8]	LBA[39:32]
Cylinder High / LBA High	LBA[23:16]	LBA[47:40]

5.3.2 LBA Addressing in DPA Mode

In DPA mode, the Sector Count, Sector Number, Cylinder Low, Cylinder High registers are 16-bit wide. Therefore, the Sector Count and the LBA address bits may be written simultaneously.

Table 31. 28-Bit LBA Address Bit Layout in DPA Mode

Register \ LBA Bits	Register Bit Location							
	7	6	5	4	3	2	1	0
Sector Number / LBA Low	7	6	5	4	3	2	1	0
Cylinder Low / LBA Mid	15	14	13	12	11	10	9	8
Cylinder High / LBA High	23	22	21	20	19	18	17	16
Device/Head	N/A	LBA	N/A	N/A	27	26	25	24

Table 32. 48-Bit LBA Address Bit Layout in DPA Mode

Register \ LBA Bits	Register Bit Location															
	15	14	13	12	11	10	9	8	7	6	5	4	3	2	1	0
Sector Number / LBA Low	31	30	29	28	27	26	25	24	7	6	5	4	3	2	1	0
Cylinder Low / LBA Mid	39	38	37	36	35	34	33	32	15	14	13	12	11	10	9	8
Cylinder High / LBA High	47	46	45	44	43	42	41	40	23	22	21	20	19	18	17	16
Device/Head									N/A	LBA	N/A	N/A	1	1	1	1

5.4 Reset Initialization

When the PCI bus reset signal P_RST# is asserted, the GD31244 controller:

- resets all internal units
- resets all the registers to their default values
- latches the configuration strap on the rising edge of P_RST#.
- latches P_REQ64# to determine the PCI bus width
- initiates a COMRESET/hardware reset to the SATA devices on the rising edge of P_RST#. Note that COMRESET is initiated only when in PCI IDE mode. When in DPA mode, COMRESET have to be explicitly initiated using the SControl Register by software. Refer to the DET field in the [“SU PCI DPA SATA SControl Register - SUPDSSCR”](#) on page 225.

All the state machines on the GD31244 controller get reset upon the assertion of the PCI bus signal P_RST#. In addition, all the registers on the GD31244 controller get initialized to their default values.

Upon the deassertion of P_RST#, the GD31244 controller samples the DPA_MODE# strap pin to set the operating mode. When DPA_MODE# is high after reset is deasserted, the GD31244 controller will present itself on the PCI bus as a PCI IDE device (Default Mode). When DPA_MODE# is low after reset, the GD31244 controller will present itself on the PCI bus in DPA (Direct Port Access) mode (requires a pull-down resistor).

The P_REQ64# signal is also sampled to determine when the GD31244 controller is connected on a 64-bit PCI bus. P_REQ64# is latched on the rising edge of P_RST#. The state of P_REQ64# at the rising edge of P_RST# notifies the GD31244 controller that it is connected to a 64-bit or 32-bit PCI bus.

The 32BITPCI# is also sampled to indicate the width of the PCI-X bus to the PCI-X Status Register. When 32BITPCI# is low after reset is deasserted, it implies a 32-bit PCI-X Bus (requires pull-down resistor). When 32BITPCI# high after reset is deasserted, it implies a 64-bit PCI-X Bus (Default mode)

A COMRESET is used to hardware reset the SATA device and also to initialize the serial bus communication link. A COMRESET is issued differently in PCI mode and DPA mode. In PCI IDE mode, upon the deassertion of P_RST#, a COMRESET is issued to each SATA drive. In DPA mode, the serial bus will stay offline after P_RST# is deasserted. Software must intervene in order to initiate a COMRESET initialization sequence using the SControl register. Refer to the [“SU PCI DPA SATA SControl Register - SUPDSSCR”](#) on page 225. This is done in order to minimize an initial power supply current draw due to multiple spindles starting at once.

A COMRESET sequence causes a hardware reset of the SATA device and initialization of the serial bus communication link. Because of the nature of the Serial ATA bus, before the SATA port may communicate to the attached SATA device, an initialization sequence is required to establish the communication link. The PHY internally provides a mechanism (PHY Ready) to indicate that a device is present. Until a device is not detected the Command Block Status register returns a 7FH value when read. This value is consistent with ATA standard devices, which indicates that a device is not connected and therefore, software should not try writing to the taskfile registers. After the device is detected, the Status register returns an 80H value. Bit 7 set (BSY bit) indicates that a device is present but is busy performing its initialization sequence. After the device completes its initialization sequence, it will send a Register FIS to initialize the taskfile registers. The values returned in the Register FIS are device dependent, and provide the status of the drive. The Error register contains a diagnostic code. The Sector Count, Sector Number, Cylinder Low, Cylinder High and Device/Head

registers contain signatures that are device dependent. Refer to the *AT Attachment with Packet Interface-6 (ATA/ATAPI-6) Specification* for more details regarding the values returned in the Device-to-Host Register FIS.

A COMRESET may also be initiated by software writing the DET field of the SControl register.

A software reset is initiated by writing a one to the SRST bit (bit 2) (software reset bit) of the Device Control register. A software reset simply initiates a device reset, and does not initiate any serial link initialization sequence as described above based on a COMRESET. After a software reset, the device will send a Device-to-Host Register FIS. The values returned in the Register FIS are device-dependent, and provide information as far as the status of the drive. The Error register contains a diagnostic code. The Sector Count, Sector Number, Cylinder Low, Cylinder High and Device/Head registers contain signatures that are device dependent. Refer to the *AT Attachment with Packet Interface-6 (ATA/ATAPI-6) Specification* for more details regarding the values returned in the Device-to-Host Register FIS.

Devices that implement the packet command set may also be reset using the DEVICE RESET command. This command may be issued to an individual device using the DEV bit without affecting the other device. After the device is reset, it will return a Device-to-Host Register FIS. The Error register contains a diagnostic code. The Sector Count, Sector Number, Cylinder Low, Cylinder High and Device/Head registers contain signatures that are device dependent. Refer to the *AT Attachment with Packet Interface-6 (ATA/ATAPI-6) Specification* for more details regarding the values returned in the Device-to-Host Register FIS.

The EXECUTE DEVICE DIAGNOSTIC command may be used to initiate a device diagnostic. After the device completes its diagnostic sequence, it will return a Device-to-Host Register FIS. The Error register contains a diagnostic code. The Sector Count, Sector Number, Cylinder Low, Cylinder High and Device/Head registers contain signatures that are device dependent. Refer to the *AT Attachment with Packet Interface-6 (ATA/ATAPI-6) Specification* for more details regarding the values returned in the Device-to-Host Register FIS.

Note: In a Master/Slave setup, the GD31244 controller will merge the contents of the taskfile Error and Status register values from the attached devices, in accordance with the ATA standard, to produce the Error and Status register values visible to host software. Refer to the *AT Attachment with Packet Interface-6 (ATA/ATAPI-6) Specification* for details.

Note: In a Master/Slave setup, a hardware reset, a software reset, and an EXECUTE DEVICE DIAGNOSTIC command will cause both master and slave devices to perform the requested task simultaneously. However, a DEVICE RESET command may be targeted at only one device at a time using the DEV bit in the Device/Head register.

5.5 Serial ATA BIST

The *Serial ATA Specification* identifies three loopback test schemes, of which one is required to be implemented:

- Far-End Retimed (required feature)
- Far-End Analog (Vendor specific)
- Near-End Analog (Vendor specific)

The GD31244 controller does not support Near-End Analog loopback. The three loopback paths are shown in [Figure 28](#), [Figure 29](#) and [Figure 30](#). A BIST test may be initiated by either the host or the device sending the BIST Activate FIS. For example, the BIST Activate FIS is bidirectional. The BIST Activate FIS contains control bits that indicate the action that the receiver should take upon receipt of the FIS. The GD31244 controller implements BIST using the [SU PCI DPA BIST FIS Control and Status Register - SUPDBFCSR](#). For example, this register is used to initiate and send a BIST Activate FIS to the receiver and is also used to notify the receipt of a BIST Activate FIS from the far-end device. In addition to the [SU PCI DPA BIST FIS Control and Status Register - SUPDBFCSR](#), the [SU PCI DPA Host BIST Data Low Register - SUPDHBDLR](#) and [SU PCI DPA Host BIST Data High Register - SUPDHBDDR](#) are used for the two data DWORDs of the BIST Activate FIS. When a BIST FIS is received, the two Data DWORDs are written into the [SU PCI DPA Device BIST Data Low Register - SUPDDBDLR](#) and [SU PCI DPA Device BIST Data High Register - SUPDDBDDR](#).

Figure 28. Far-End Retimed Loopback Setup

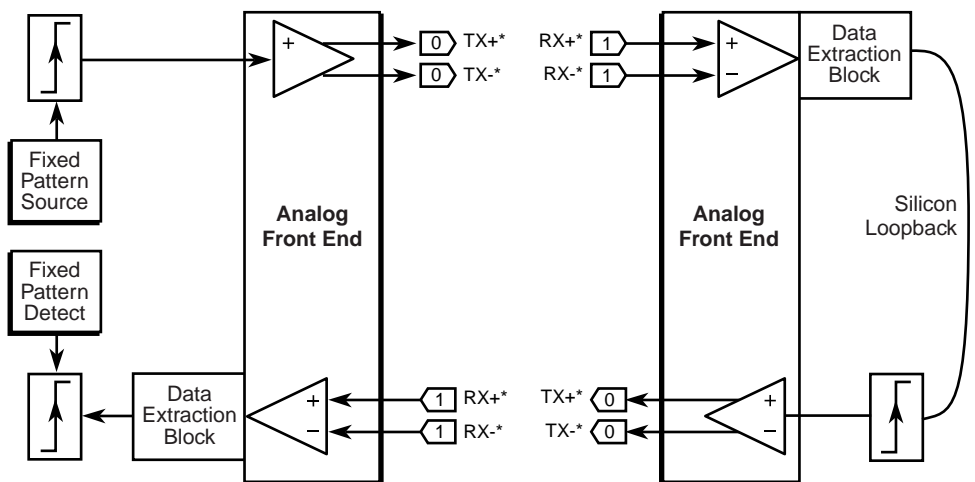

B1247-01

Figure 29. Far-End Analog Loopback Setup

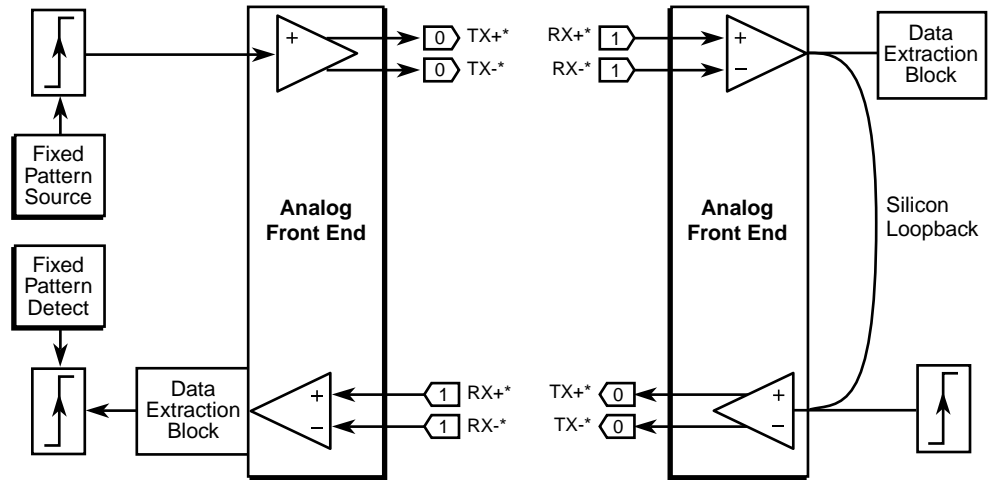

B1249-01

Figure 30. Near-End Analog Loopback Setup

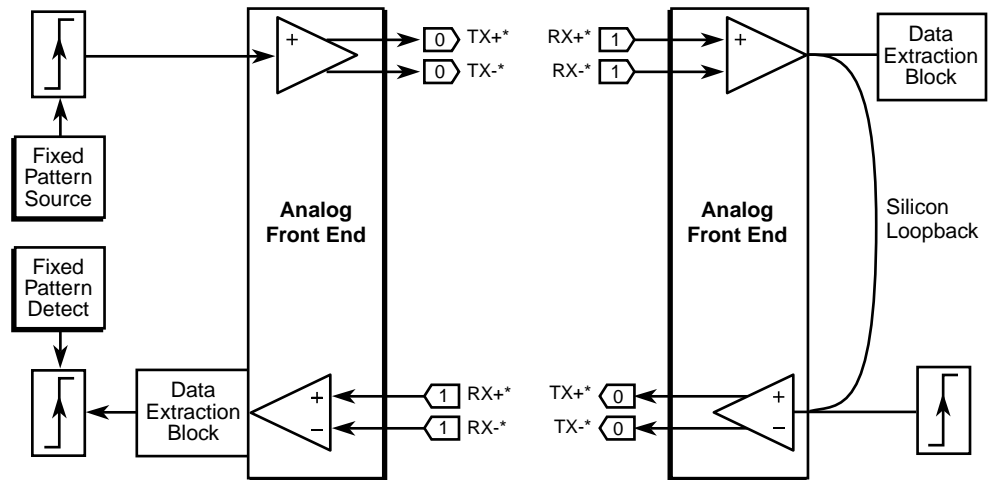

B1250-01

5.5.1 Loopback Mode Testing

In the loopback modes (Far-End Retimed or Far-End Analog), the GD31244 controller may be programmed to generate one of four BIST patterns:

- 00_2 - D2.5s
- 01_2 - D24.3s
- 10_2 - 3(D10.2s) and K28.5
- 11_2 - 16-bit counting pattern

A BIST pattern is selected by programming bits [31:30] of the [SU PCI DPA BIST FIS Control and Status Register - SUPDBFCSR](#). Programming bits [31:30] with 00_2 will generate a stream of D2.5 data characters. Programming bits [31:30] with 01_2 will generate a stream of D24.3 data characters. Programming bits [31:30] with 10_2 will generate a stream of three D10.2 data and one K28.5 control characters. Programming bits [31:30] with 11_2 will generate a 16-bit counting pattern. The counting pattern is a sequence of 65536 DWORDs, repeated indefinitely until the test is concluded. Each sequence contains DWORDs incremented by one starting with (DWORD = 0000_0000H) and ends with (DWORD = FFFF_FFFFH). For example, the sequence looks as such: 0000_0000H, 0001_0001H, 0002_0002H, -----, FFFE_FFFEh, and FFFF_FFFFH. Note that the upper 16-bit of each DWORD is also incremented in the same manner as the lower 16-bit, and therefore looks exactly the same as the lower 16-bit.

Before initiating the transfer of a BIST Activate FIS, bits [6:1] of the [SU PCI DPA BIST FIS Control and Status Register - SUPDBFCSR](#) must be set appropriately. For example, to command the receiver into a Far-End Retimed loopback mode, bit 3 (BIST FIS retimed bit) of the [SU PCI DPA BIST FIS Control and Status Register - SUPDBFCSR](#) must be set. And to command the receiver into the Far-End Analog loopback mode, bit 1 (BIST FIS AFE loopback bit) must be set. After the appropriate bit(s) are set in bits [6:1], the BIST Activate FIS may be sent to the receiving device by setting bit 7.

The GD31244 controller also provides the following registers in order to monitor the BIST tests: [SU PCI DPA BIST Errors Register - SUPDBER](#) and [SU PCI DPA BIST Frames Register - SUPDBFR](#). The [SU PCI DPA BIST Errors Register - SUPDBER](#) is used to keep track of the number of errors detected. The [SU PCI DPA BIST Frames Register - SUPDBFR](#) is used when BIST pattern (11_2 - 16-bit Counting pattern) is selected. This register keeps track of the number of BIST frames encountered. A frame is defined as one of the 16-bit counting pattern sequence described above.

These steps provide an example of how a loopback test may be setup and initiated:

1. Set bit 25, this will clear/reset the BIST Errors and BIST Frames registers.
2. Set bits [31:30] to select one of the BIST patterns.
3. Set bits [29:28], must be set with the same value as bits [31:30] respectively. These bits indicate the pattern that the checker uses to compare the incoming data stream against.
4. Set bit 1 or bit 3 to select AFE or Retimed loopback respectively.
5. Set bit 24, this bit enables the pattern generator.
6. Set bit 23, this bit enables the pattern checker.

Note: To conclude the loopback test, the far-end device must be reset using a COMRESET/COMINIT sequence.

5.5.2 Transmit-Only Mode Testing

The BIST Activate FIS may also be used to place the receiver in a transmit-only mode. The receiver sends the pattern indicated in the two DWORDs of the BIST Activate FIS that was sent. In this mode, the GD31244 controller does not check the incoming data patterns. Before sending a BIST Activate FIS, bit 6 (BIST FIS transmit only bit) must be set and optionally bit 5 (BIST FIS align bypass bit), bit 4 (BIST FIS scrambling bypass bit), and BIST FIS primitive bit). Bits 5, 4, and 2 are only used in conjunction with bit 6. Refer to the SATA specification for more details.

Note: To conclude the transmit-only test, the far-end device must be reset using a COMRESET/COMINIT sequence.

The GD31244 controller may also be setup to send the following patterns to the far-end device:

- A stream of K28.5s. This is done by setting bit 16 of the [SU PCI DPA BIST FIS Control and Status Register - SUPDBFCSR](#).
- A stream of K28.7s. This is done by setting bit 8 of the [SU PCI DPA BIST FIS Control and Status Register - SUPDBFCSR](#).
- Content of the [SU PCI DPA Host BIST Data Low Register - SUPDHBDLR](#) and the [SU PCI DPA Host BIST Data Low Register - SUPDHBDLR](#) DWORDs. This is done by first loading [SU PCI DPA Host BIST Data Low Register - SUPDHBDLR](#) and [SU PCI DPA Host BIST Data Low Register - SUPDHBDLR](#) with the appropriate values to be transmitted, followed by setting bit 6 and setting bit 0 of the [SU PCI DPA BIST FIS Control and Status Register - SUPDBFCSR](#). Bits 5, 4, and 2 of the [SU PCI DPA BIST FIS Control and Status Register - SUPDBFCSR](#) may optionally be set accordingly.

5.6 PCI Bus Error Conditions

This section describes error handling that occurs on the PCI bus.

PCI error conditions cause state machines to exit normal operation and return to idle states. In addition, status bits are set to inform error handling code of exact cause of error condition. Error conditions and status may be found in the SUSR. PCI errors are reported by setting the bit(s) in the SU Status Register, which correspond to the error condition (master abort, target abort, etc.)

PCI bus error conditions and the action taken on the bus are defined within the *PCI Local Bus Specification*, Revision 2.2, and the *PCI-X Addendum to the PCI Local Bus Specification*, Revision 1.0a. The GD31244 controller adheres to the error conditions defined within the PCI specification for both requester and target operation.

5.6.1 Address and Attribute Parity Errors on the PCI Interface

The GD31244 controller must detect and report address and attribute (PCI-X mode only) parity errors for transactions on the PCI bus. When an address or attribute parity error occurs on the PCI interface of the GD31244 controller, the following actions based on the constraints specified:

- In either Conventional mode or PCI-X mode, when the Parity Error Response bit in the SUCMD is set, the GD31244 controller will target abort the following transactions: Configuration Read, Configuration Write, I/O Read, I/O Write, and Memory Read. When the Parity Error Response bit is clear, the transaction will proceed normally. Note that Memory Write and Outbound Split Completion will complete normally as when there was no parity errors. For transactions that terminate with a target abort, the following action is taken by the GD31244 controller:
 - Set the Target Abort (target) bit (bit 11) in the SUSR.
- Assert **SERR#** when the **SERR#** Enable bit and the Parity Error Response bit in the SUCMD are set. When the GD31244 controller asserts **SERR#**, additional action is taken:
 - Set the **SERR#** Asserted bit in the SUSR.
- Set the Detected Parity Error bit in the SUSR.

5.6.2 Data Parity Errors on the PCI Interface

Two kinds of data parity errors may occur on the PCI interface:

Errors encountered as an initiator:

- Outbound Read Request
- Outbound Write Request

As an initiator, the GD31244 controller provides an error response for data parity errors on outbound reads, and data parity errors occurring at the target for outbound writes.

Errors encountered as a target:

- Inbound Read Request (Immediate Data Transfer)
- Inbound Write Request
- Split Completion Messages
- Outbound Read Completion

As a target, the GD31244 controller provides an error response for data parity errors on inbound writes, inbound configuration writes, and split completion messages. However, there will be no error response for data parity errors on inbound reads.

5.6.2.1 Outbound Read Request Data Parity Errors

5.6.2.1.1 Immediate Data Transfer

As an initiator, the GD31244 controller may encounter this error condition in Conventional or PCI-X mode when the target transfers data immediately rather than signalling a Retry¹ (Conventional Delayed Read Request) or a Split Response Termination (PCI-X Split Read Request).

Data parity errors occurring during read operations initiated by the GD31244 controller are recorded, **PERR#** is asserted (when enabled) and **SERR#** is asserted (when enabled). Specifically, the following actions with the given constraints are taken by the GD31244 controller:

- **PERR#** is asserted two clocks cycles (three clock cycles when operating in the PCI-X mode) following the data phase in which the data parity error is detected on the bus. This is only done when the Parity Error Response bit in the SUCMD is set. When the GD31244 controller asserts **PERR#**, additional actions will be taken:
 - The Master Parity Error bit in the SUSR is set.
 - When the GD31244 controller is operating in the PCI-X mode, the **SERR#** Enable bit in the SUCMD is set, and the Data Parity Error Recover Enable bit in the SUPCIXCMD register is clear, assert **SERR#**, otherwise no action. When the GD31244 controller asserts **SERR#**, additional action is taken:
 - Set the **SERR#** Asserted bit in the SUSR.
- The Detected Parity Error bit in the SUSR is set.
- Set the DMA Error bit and clear the DMA Active bit in the DMA Status register.

1. Retry terminations may also be signaled in PCI-X mode when the target is too busy to handle the current request. However, this is not the same as a Delayed Read Request in Conventional PCI mode since the requester is not required or expected by the target to return with the same read request.

5.6.2.1.2 Split Response Termination

As an initiator, the GD31244 controller may encounter this error condition in PCI-X mode when the target signals a Split Response Termination.

Parity errors occurring during Split Response Terminations of Read Requests by the GD31244 controller are recorded, **PEERR#** is asserted (when enabled) and **SERR#** is asserted (when enabled). Specifically, the following actions with the given constraints are taken by the GD31244 controller:

- **PEERR#** is asserted three clock cycles following the Split Response Termination in which the parity error is detected on the bus. This is only done when the Parity Error Response bit in the SUCMD is set. When the GD31244 controller asserts **PEERR#**, additional actions will be taken:
 - The Master Parity Error bit in the SUSR is set.
 - When the **SERR#** Enable bit in the SUCMD is set, and the Data Parity Error Recover Enable bit in the SUPCIXCMD register is clear, assert **SERR#**, otherwise no action. When the GD31244 controller asserts **SERR#**, additional action is taken:
 - Set the **SERR#** Asserted bit in the SUSR.
- The Detected Parity Error bit in the SUSR is set.
- Set the DMA Error bit and clear the DMA Active bit in the DMA Status register.

5.6.2.2 Outbound Write Request Data Parity Errors

5.6.2.2.1 Outbound Writes that are Not MSI (Message Signaled Interrupts)

As an initiator, the GD31244 controller may encounter this error condition when operating in either the Conventional or PCI-X modes.

Data parity errors occurring during write operations initiated by the GD31244 controller may record the assertion of **PERR#** from the target on the PCI Bus. Specifically, the following actions with the given constraints are taken by the GD31244 controller:

- When **PERR#** is sampled active and the Parity Error Response bit in the SUCMD is set, set the Master Parity Error bit in the SUSR. When the Parity Error Response bit in the SUCMD is clear, no action is taken. When the Master Parity Error bit in the SUSR is set, additional actions will be taken:
 - When the GD31244 controller is operating in the PCI-X mode, the **SERR#** Enable bit in the SUCMD is set, and the Data Parity Error Recover Enable bit in the SUPCIXCMD register is clear, assert **SERR#**, otherwise no action. When the GD31244 controller asserts **SERR#**, additional action is taken:
Set the **SERR#** Asserted bit in the SUSR.
- Set the DMA Error bit and clear the DMA Active bit in the DMA Status register.

5.6.2.2.2 MSI Outbound Writes

As an initiator, the GD31244 controller may encounter this error condition when operating in either the Conventional or PCI-X modes.

Data parity errors occurring during MSI write operations initiated by the GD31244 controller may record the assertion of **PERR#** from the target on the PCI Bus. When an error occurs, the GD31244 controller will complete the transaction normally. Then, the following actions with the given constraints are taken by the GD31244 controller:

- When **PERR#** is sampled active and the Parity Error Response bit in the SUCMD is set, set the Master Parity Error bit in the SUSR. When the Parity Error Response bit in the SUCMD is clear, no action is taken. When the Master Parity Error bit in the SUSR is set, additional actions will be taken:
 - When the **SERR#** Enable bit in the SUCMD is set, assert **SERR#**, otherwise no action. When the GD31244 controller asserts **SERR#**, additional actions will be taken:
Set the **SERR#** Asserted bit in the SUSR.

5.6.2.3 Inbound Read Request Data Parity Errors

5.6.2.3.1 Immediate Data Transfer

As a target, the GD31244 controller may encounter this error when operating in the Conventional PCI or PCI-X modes.

Inbound read data parity errors occur when read data delivered from the inbound read queue is detected as having bad parity by the initiator of the transaction who is receiving the data. The initiator may optionally report the error to the system by asserting **PERR#**. As a target device in this scenario, no action is required and no error bits are set.

5.6.2.4 Inbound Write Request Data Parity Errors

As a target, the GD31244 controller may encounter this error when operating in the Conventional or PCI-X modes.

Data parity errors occurring during write operations received by the GD31244 controller may assert **PERR#** on the PCI Bus. Specifically, the following actions with the given constraints are taken by the GD31244 controller:

- **PERR#** is asserted two clock cycles (three clock cycles when operating in the PCI-X mode) following the data phase in which the data parity error is detected on the bus. This is only done when the Parity Error Response bit in the SUCMD is set.
- The Detected Parity Error bit in the SUSR is set.

5.6.2.5 Outbound Read Completion Data Parity Errors

As a target, the GD31244 controller may encounter this error when operating in the PCI-X mode.

Data parity errors occurring during read completion transactions that are claimed by the GD31244 controller are recorded, **PERR#** is asserted (when enabled) and **SERR#** is asserted (when enabled). Specifically, the following actions with the given constraints are taken by the GD31244 controller:

- **PERR#** is asserted three clock cycles following the data phase in which the data parity error is detected on the bus. This is only done when the Parity Error Response bit in the SUCMD is set. When the GD31244 controller asserts **PERR#**, additional actions are taken:
 - The Master Parity Error bit in the SUSR is set.
 - When the **SERR#** Enable bit in the SUCMD is set, and the Data Parity Error Recover Enable bit in the SUPCIXCMD register is clear, assert **SERR#**, otherwise no action. When the GD31244 controller asserts **SERR#**, additional action is taken:
 - Set the **SERR#** Asserted bit in the SUSR.
- The Detected Parity Error bit in the SUSR is set.
- Set the DMA Error bit and clear the Active bit in the DMA Status register.

5.6.2.6 Split Completion Messages

As a target, the GD31244 controller may encounter this error when operating in the PCI-X Mode.

Data parity errors occurring during Split Completion Messages claimed by the GD31244 controller may assert **PERR#** (when enabled) or **SERR#** (when enabled) on the PCI Bus. When an error occurs, the GD31244 controller will accept the data and complete normally. Specifically, the following actions with the given constraints are taken by the GD31244 controller:

- **PERR#** is asserted three clocks cycles following the data phase in which the data parity error is detected on the bus. This is only done when the Parity Error Response bit in the SUCMD is set. When the GD31244 controller asserts **PERR#**, additional actions are taken:
 - The Master Parity Error bit in the SUSR is set.
 - When the **SERR#** Enable bit in the SUCMD is set, and the Data Parity Error Recover Enable bit in the SUPCIXCMD register is clear, assert **SERR#**; otherwise no action is taken. When the GD31244 controller asserts **SERR#**, additional action is taken:
Set the **SERR#** Asserted bit in the SUSR.
- When the SCE bit (Split Completion Error -- bit 30 of the Completer Attributes) is set during the Attribute phase, the Received Split Completion Error Message bit in the SUPCIXSR is set. When the GD31244 controller sets this bit, additional actions are taken:
 - The Detected Parity Error bit in the SUSR is set.
 - Set the DMA Error bit and clear the DMA Active bit in the DMA Status register.

5.6.3 Master Aborts on the PCI Interface

As an initiator on the PCI bus, the GD31244 controller may encounter master abort conditions during:

- Outbound Read Request
- Outbound Write Request
- Outbound Read Completion

As a target, the GD31244 controller PCI interface is capable of signaling a master abort case during:

- Address Parity Error (Conventional Mode)
- Inbound Read Request (PCI-X Mode)

5.6.3.1 Master-Aborts Signaled by Intel® 31244 PCI-X to Serial ATA Controller as an Initiator

5.6.3.1.1 Master Aborts for Outbound Read or Write Request

This error may be encountered in both the Conventional and the PCI-X modes. For an Outbound transaction, there are two ways in which a Master-Abort may be signaled to the GD31244 controller:

1. In the Conventional or PCI-X modes, a master abort is signaled when the target of the transaction does not assert **DEVSEL#** within five clocks (seven clocks when operating in the PCI-X Mode) of the assertion of **FRAME#**.
2. In PCI-X mode, the GD31244 controller may initiate a split request (read request) to the target-side interface of a PCI-to-PCI bridge. When the PCI-to-PCI bridge detects a Master Abort on its initiating interface for that Split Request, master abort is signaled to GD31244 controller through a Master-Abort Split Completion Error Message (class=1h - bridge error and index=00h - Master Abort). The following actions with given constraints are performed by GD31244 controller when a master abort is detected by the PCI initiator interface or the PCI target interface receives a Master-Abort Split Completion error message:
 - Set the Master Abort bit (bit 13) in the SUSR.
 - When the transaction is an MSI outbound write and the **SERR#** Enable bit in the SUCMD is set, assert **SERR#**, otherwise no action. When the GD31244 controller asserts **SERR#**, additional action is taken:
Set the **SERR#** Asserted bit in the SUSR
 - When operating in PCI-X mode and Master-Abort is signaled through a Split Completion Error Message, the Received Split Completion Error Message bit in SUPCIXSR is set.
 - Set the DMA Error bit and clear the DMA Active bit in the DMA Status register.

5.6.3.2 Master-Aborts Signaled by Intel® 31244 PCI-X to Serial ATA Controller as a Target

5.6.3.2.1 Unsupported PCI Commands

When the GD31244 controller encounters a PCI or PCI-X command on an inbound transaction that is not supported, it will signal a master abort by not asserting **DEVSEL#**. Refer to [Table 3 on page 23](#) and [Table 4 on page 24](#).

5.6.3.2.2 PCI IDE Control Block Registers

In PCI IDE mode, the Control Block registers are located in the I/O space, and the smallest amount of I/O space that a Base Address Register may request is four bytes. The Control Block is accessed using Base Address Registers 1 and 3 for the primary and secondary channels respectively. In this four byte allocation for the Control Block, the byte at offset 02H is where the Alternate Status/Device Control registers are located. The GD31244 controller will master abort access made to the bytes at offsets (00H, 01H, and 03H) by not asserting **DEVSEL#**.

5.6.4 Target Aborts on the PCI Interface

As an initiator on the PCI bus, the GD31244 controller may encounter target abort conditions during:

- Outbound Read Request
- Outbound Write Request
- Outbound Read Completion

As a target, the GD31244 controller PCI interface is capable of signaling a target abort case during:

- Configuration Read
- Configuration Write
- I/O Read
- I/O Write
- Memory Read

5.6.4.1 Target Aborts for Outbound Read Request or Outbound Write Request

This error may be encountered by the GD31244 controller in both the Conventional and PCI-X modes. For an Outbound transaction, there are two ways in which a Target-Abort may be signaled to the GD31244 controller:

1. In the Conventional or PCI-X modes, a target abort is signaled when the target of the transaction simultaneously deasserts **DEVSEL#**, deasserts **TRDY#**, and asserts **STOP#**.
2. In PCI-X mode, the GD31244 controller may initiate a split request (read request) to the target-side interface of a PCI-to-PCI bridge. When the PCI-to-PCI bridge detects a Target Abort on its initiating interface for that Split Request, target abort is signaled to GD31244 controller through a Target-Abort Split Completion Error Message (class = 1h - bridge error and index = 01h - Target Abort). The following actions with the given constraints are performed by the GD31244 controller when a target abort is detected by the PCI initiator interface or the PCI target interface receives a Target-Abort Split Completion error message:
 - Set the Target Abort (master) bit (bit 12) in the SUSR.
 - When the transaction is an MSI outbound write and the **SERR#** Enable bit in the SUCMD is set, assert **SERR#**; otherwise, no action is taken. When the GD31244 controller asserts **SERR#**, additional action is taken:
Set the **SERR#** Asserted bit in the SUSR.
 - When operating in the PCI-X mode and the Target-Abort is signaled through a Split Completion Error Message, the Received Split Completion Error Message bit in the SUPCIXSR is set.
 - Set the DMA Error bit and clear the DMA Active bit in the DMA Status register.

5.6.4.2 Target-Aborts Signaled by Intel® 31244 PCI-X to Serial ATA Controller as a Target

5.6.4.2.1 Configuration Read and Write

In both Conventional PCI and PCI-X modes, when an address parity error or attribute parity error (PCI-X Mode only) is detected during a Configuration read or write, the GD31244 controller will target abort the transaction. The following action is taken when the GD31244 controller signal a target abort:

- Set the Target Abort (target) bit (bit 11) in the SUSR.

5.6.4.2.2 I/O Read and Write

In both Conventional PCI and PCI-X modes, when an address parity error or attribute parity error (PCI-X Mode only) is detected during a I/O read or write, the GD31244 controller will target abort the transaction. The following action is taken when the GD31244 controller signal a target abort:

- Set the Target Abort (target) bit (bit 11) in the SUSR.

5.6.4.2.3 Memory Read

In both Conventional PCI and PCI-X modes, when an address parity error or attribute parity error (PCI-X Mode only) is detected during a Memory read, the GD31244 controller will target abort the transaction. Note that an address or attribute parity error occurring on a Memory write is completed normally as when no error occurred. The following action is taken when the GD31244 controller signal a target abort:

- Set the Target Abort (target) bit (bit 11) in the SUSR.

5.6.5 Corrupted or Unexpected Split Completions

Warning: When any of the errors discussed in this section actually occur, a catastrophic system failure is likely to result from which the *PCI-X Addendum to the PCI Local Bus Specification*, Revision 1.0a provides no recovery mechanism. In these cases, the GD31244 controller may be communicating with a non-compliant target device or the system may not be configured properly.

5.6.5.1 Completer Address

The GD31244 controller will assert **DEVSEL#** for split completion transactions where only the Requester ID matches that of a currently outstanding split request in the outbound transaction queue. For example, the Tag does not have to match.

However, the GD31244 controller will discard the data of a split completion with an unmatched Tag and set the Unexpected Split Completion bit (bit 19) in the SUPCIXSR. The SATA Ports' DMAs are not halted in this situation.

When the Sequence ID of a split completion transaction matches that of an outstanding request, but the Lower Address field is not valid, the GD31244 controller will accept the split completion transaction in its' entirety according to the invalid Lower Address field as when nothing happened.

5.6.5.2 Completer Attributes

When the Sequence ID of a split completion transaction matches that of an outstanding request, but the Byte Count is not valid, the GD31244 controller will accept the split completion transaction in its entirety according to the invalid byte count field as when nothing happened.

5.6.6 SERR# Assertion and Detection

The GD31244 controller is capable of reporting error conditions through the use of the **SERR#** output.

The following conditions may result in the assertion of **SERR#** by the GD31244 controller:

- An address parity error (or an attribute parity error when operating in the PCI-X mode) is detected by the GD31244 controller PCI interface (see [Section 5.6.1, “Address and Attribute Parity Errors on the PCI Interface” on page 83](#) for details).
- A Master Data Parity Error is recorded in the SUSR while operating in the PCI-X mode (see [Section 5.6.2, “Data Parity Errors on the PCI Interface” on page 84](#) for details).
- An outbound MSI write transaction is either signaled a Master-Abort or a Target-Abort by the target.

The following actions with the given constraints are performed by the GD31244 controller when **SERR#** is asserted by the GD31244.

- Set the **SERR#** Asserted bit in the SUSR.

Note: GD31244 does not detect **SERR#** on the bus, and does not take any action for **SERR#** asserted by other PCI/X devices.

5.6.7 PCI Error Summary

Table 17 summarizes the GD31244 controller error reporting for PCI bus errors. The table assumes that all error reporting is enabled through the appropriate command registers (unless otherwise noted). The SU Status Register records PCI bus errors. Note that the **SERR#** Asserted bit in the Status Register is set only when the **SERR#** Enable bit in the Command Register is set.

Table 33. 31244 Controller Error Reporting Summary - PCI Interface (Sheet 1 of 3)

Error Condition ^a (Bus Mode ^b)	Bits Set in SU Status Register (SUSR ^c) or SU PCI-X Status Register (SUPCIXSR ^d)	PCI IDE Mode SU IDE Channel 0 DMA Status Register (SUICDSR0) or SU IDE Channel 1 DMA Status Register (SUICDSR1)	DPA Mode SU PCI DMA Status Register (SUPDDSR)
	PCI Bus Error Response (i.e., signal Target-Abort, signal Master-Abort etc.)	DMA Action	DMA Action
Address or Attribute Parity Error (Both)	Target Abort (target) - bit 11 of SUSR for the following transactions: Configuration Read, Configuration Write, I/O write, I/O Read, and Memory Read. Memory Write and Outbound Read Split Completion do not signal a target abort.	None	None
(Both)	SERR# Asserted - bit 14 of SUSR		
(Both)	Detected Parity Error - bit 15 of SUSR		
Outbound Read Request (Immediate Data Transfer) Parity Error (Both)	Signal PERR# (both) SERR# (PCI-X Mode Only).	<ul style="list-style-type: none"> Set DMA Error - bit 1 Clear DMA Active - bit 0 	<ul style="list-style-type: none"> Set DMA Error - bit 1 Clear DMA Active - bit 0
(Both)	Master Parity Error - bit 8 SUSR		
(PCI-X)	SERR# Asserted - bit 14 SUSR		
(Both)	Detected Parity Error - bit 15 of SUSR		
Outbound Read Request (Split Response Termination) Parity Error (PCI-X)	Signal PERR# and SERR#	<ul style="list-style-type: none"> Set DMA Error - bit 1 Clear DMA Active - bit 0 	<ul style="list-style-type: none"> Set DMA Error - bit 1 Clear DMA Active - bit 0
(PCI-X)	Master Parity Error - bit 8 SUSR		
(PCI-X)	SERR# Asserted - bit 14 SUSR		
(PCI-X)	Detected Parity Error - bit 15 of SUSR		
Outbound Read Completion Parity Error (PCI-X)	Signal PERR# and SERR#	<ul style="list-style-type: none"> Set DMA Error - bit 1 Clear DMA Active - bit 0 	<ul style="list-style-type: none"> Set DMA Error - bit 1 Clear DMA Active - bit 0
(PCI-X)	Master Parity Error - bit 8 SUSR		
(PCI-X)	SERR# Asserted - bit 14 SUSR		
(PCI-X)	Detected Parity Error - bit 15 of SUSR		
Outbound Write Request Parity Error (Both)	Signal SERR# (only for PCI-X or MSI Writes).	<ul style="list-style-type: none"> Set DMA Error - bit 1 Clear DMA Active - bit 0 	<ul style="list-style-type: none"> Set DMA Error - bit 1 Clear DMA Active - bit 0
(Both)	Master Parity Error - bit 8 of SUSR		
(PCI-X or MSI)	SERR# Asserted - bit 14 of SUSR		

Table 33. 31244 Controller Error Reporting Summary - PCI Interface (Sheet 2 of 3)

Error Condition ^a (Bus Mode ^b)	Bits Set in SU Status Register (SUSR ^c) or SU PCI-X Status Register (SUPCIXSR ^d)	PCI IDE Mode SU IDE Channel 0 DMA Status Register (SUICDSR0) or SU IDE Channel 1 DMA Status Register (SUICDSR1)	DPA Mode SU PCI DMA Status Register (SUPDDSR)
	PCI Bus Error Response (i.e., signal Target-Abort, signal Master-Abort etc.)	DMA Action	DMA Action
Inbound Read Request (Immediate Data Transfer) Parity Error (Both)			
Inbound Write Request Parity Error (Both)	Signal PERR# .		
(Both)	Detected Parity Error - bit 15 of SUSR		
Split Completion Message Parity Error (PCI-X)	Signal PERR# and SERR# .	<ul style="list-style-type: none"> • Set DMA Error - bit 1 • Clear DMA Active - bit 0 	<ul style="list-style-type: none"> • Set DMA Error - bit 1 • Clear DMA Active - bit 0
(PCI-X)	Master Parity Error - bit 8 of SUSR		
(PCI-X)	SERR# Asserted - bit 14 of SUSR		
(PCI-X and SCE ^e)	Received Split Completion Error Message - bit 29 SUPCIXSR		
(PCI-X)	Detected Parity Error - bit 15 of SUSR		
Outbound Read Request Master-Abort (Both)	None	<ul style="list-style-type: none"> • Set DMA Error - bit 1 • Clear DMA Active - bit 0 	<ul style="list-style-type: none"> • Set DMA Error - bit 1 • Clear DMA Active - bit 0
(Both)	Master Abort - bit 13 of SUSR		
(PCI-X and SCE)	Received Split Completion Error Message - bit 29 of SUPCIXSR		
Outbound Write Request Master-Abort (Both)	Signal SERR# (MSI)	<ul style="list-style-type: none"> • Set DMA Error - bit 1 • Clear DMA Active - bit 0 	<ul style="list-style-type: none"> • Set DMA Error - bit 1 • Clear DMA Active - bit 0
(Both)	Master Abort - bit 13 of SUSR		
(MSI)	SERR# Asserted - bit 14 of SUSR		
Inbound Read Request Target-Abort (Both)			
(Both)	Target Abort (target) - bit 11 of SUSR		
Inbound Write Request Target-Abort (Both)			
(Both)	Target Abort (target) - bit 11 of SUSR		
Outbound Read Request Target-Abort (Both)		<ul style="list-style-type: none"> • Set DMA Error - bit 1 • Clear DMA Active - bit 0 	<ul style="list-style-type: none"> • Set DMA Error - bit 1 • Clear DMA Active - bit 0
(Both)	Target Abort (master) - bit 12 of SUSR		
(PCI-X and SCE)	Received Split Completion Error Message - bit 29 of SUPCIXSR		
Outbound Write Request Target-Abort (Both)	Signal SERR# (MSI)	<ul style="list-style-type: none"> • Set DMA Error - bit 1 • Clear DMA Active - bit 0 	<ul style="list-style-type: none"> • Set DMA Error - bit 1 • Clear DMA Active - bit 0
(Both)	Target Abort (master) - bit 12 of SUSR		

Table 33. 31244 Controller Error Reporting Summary - PCI Interface (Sheet 3 of 3)

Error Condition ^a (Bus Mode ^b)	Bits Set in SU Status Register (SUSR ^c) or SU PCI-X Status Register (SUPCIXSR ^d)	PCI IDE Mode SU IDE Channel 0 DMA Status Register (SUICDSR0) or SU IDE Channel 1 DMA Status Register (SUICDSR1)	DPA Mode SU PCI DMA Status Register (SUPDDSR)
	PCI Bus Error Response (i.e., signal Target-Abort, signal Master-Abort etc.)	DMA Action	DMA Action
(MSI)	SERR# Asserted - bit 14 of SUSR		
Unexpected Split Completion (PCI-X)	In the PCI-X mode, the transaction will complete normally according to the invalid lower address field or invalid byte count.	None	None
(PCI-X)	Unexpected Split Completion bit set only for an unmatched Tag - bit 19	None	None

- a. All parity errors refer to data parity errors except where otherwise noted.
- b. Codes for bus mode in which this error response applies: PCI-X means PCI-X Mode Only, Conventional means Conventional PCI Mode Only, and Both means that the error response applies both in the Conventional and PCI-X mode of operation. MSI stands for Message-Signaled Interrupts and refers to an Outbound Write transaction that is actually an MSI write transaction.
- c. Table assumes that Parity Error Response - bit 6 of the SUCMD register is set.
- d. Table assumes that Data Parity Recovery Enable - bit 0 of the SUPCIXCMD is clear.
- e. When the SCE bit (bit 30 of the Completer Attributes) and the SCM bit (bit 29 of the Completer Attributes) are set during the Attribute phase of a Split Completion Transaction, the transaction is a Split Completion Message that is an Error Message. In this case, the Received Split Completion Error Message - bit 29 of the SUPCIXSR is set.

5.7 Serial ATA Bus and Device Error Conditions

This section describes error handling that are specific to the Serial ATA bus and Serial ATA device.

5.7.1 Serial ATA Device Error Conditions

These are error conditions that are generated by the SATA device itself. For example, when an ATA command is not supported by a device, the device will respond by returning a command-aborted error condition. The SATA device reports error conditions through the Command Block Status and Error registers. The bits in the Error register are only valid when the ERR bit (bit 0) of the Status register is set. A device reports error conditions by sending a Device-to-Host Register FIS or a PIO Setup FIS.

5.7.2 Serial ATA Bus and Protocol Error Conditions

Serial ATA bus and protocol related errors are reported in the SATA SError register. Some of the errors reported may generate interrupts that are posted in the SATA Interrupt Pending register. Refer to [Section 5.10.8.1, “SU PCI DPA Interrupt Pending Register - SUPDIPR” on page 194](#) and [Section 5.10.12.2, “SU PCI DPA SATA SError Register - SUPDSSER” on page 222](#). [Table 34](#) summarizes all the SATA bus related error conditions reported by the GD31244 controller.

Table 34. 31244 Controller Serial ATA Protocol and Bus Error Conditions (Sheet 1 of 2)

Bit	Description
31-26	Reserved
25	DIAG_F - Invalid FIS Type: When set to one, this bit indicates that the FIS type field was not recognized. For example the FIS is invalid. This bit is cleared by writing a 1 to it.
24	DIAG_T - Reserved, not implemented.
23	DIAG_S - Reserved, not implemented.
22	DIAG_H - Handshake Error: When set to one, this bit indicates that one or more R_ERR handshake response was received in response to frame transmission. Such errors may be the result of a CRC error detected by the receiver. This bit is cleared by writing a 1 to it. This bit is reported as an interrupt on bit 3, 11, 19, and 27 of the SATA Interrupt Pending register for SATA ports 0, 1, 2, and 3 respectively. Refer to Table 116, “SU PCI DPA Interrupt Pending Register - SUPDIPR” on page 194 .
21	DIAG_C - CRC Error: When set to one, this bit indicates that one or more CRC errors occurred. This bit is set when a CRC error is detected when receiving a Data FIS only. This bit is cleared by writing a 1 to it. This bit is reported as an interrupt on bit 6, 14, 22, and 30 of the SATA Interrupt Pending register for SATA ports 0, 1, 2, and 3 respectively. Refer to Table 116, “SU PCI DPA Interrupt Pending Register - SUPDIPR” on page 194 .
20	DIAG_D - Disparity Error: When set to one, this bit indicates that incorrect disparity was detected one or more times since the last time this bit was cleared. This bit is set when a Disparity error is detected when receiving a Data FIS only. This bit is cleared by writing a 1 to it.
19	DIAG_B - not implemented.
18	DIAG_W - Comm Wake: When set to one, this bit indicates that a Comm Wake was detected by the PHY. This bit is cleared by writing a 1 to it. The default value after reset is 0 ₂ . After Comm Wake is detected, the value will change to 1 ₂ .

Table 34. 31244 Controller Serial ATA Protocol and Bus Error Conditions (Sheet 2 of 2)

Bit	Description
17	DIAG_I - Reserved, not implemented.
16	<p>DIAG_N - PHYRDY Change State:</p> <p>When set to one this bit indicates that the PHYRDY signal changed state. State change means going from ready-to-not ready or not ready-to-ready. This bit shall remain cleared when the PHY was not detected as ready during the initialization process. When the PHY goes ready after initialization, this bit shall transition to 1. This bit is cleared by writing a 1 to it. This bit is reported as an interrupt on bit 0, 8, 16, and 24 of the SATA Interrupt Pending register for SATA ports 0, 1, 2, and 3 respectively. Refer to Table 116, "SU PCI DPA Interrupt Pending Register - SUPDIPR" on page 194.</p> <p>The default value after reset is 0₂, for example the PHY will not be ready. When the PHY becomes ready (state change from not ready to ready) as part of the initialization sequence, the value will change to 1₂.</p>
15-12	Reserved.
11	<p>ERR_E - Internal Error:</p> <p>This bit indicates that a FIFO error occurred due to a FIFO overrun or underrun condition. This bit is cleared by writing a 1 to it. This bit is reported as an interrupt on bit 2, 10, 18, and 26 of the SATA Interrupt Pending register for SATA ports 0, 1, 2, and 3 respectively. Refer to Table 116, "SU PCI DPA Interrupt Pending Register - SUPDIPR" on page 194.</p>
10	<p>ERR_P - Protocol Error:</p> <p>This bit when set indicates that a corrupted FIS was received. This bit may indicate that the FIS received was an invalid FIS type or that the received FIS was not properly structured. For example, incorrect length. This bit is cleared by writing a 1 to it. This bit is reported as an interrupt on bit 4, 12, 20, and 28 of the SATA Interrupt Pending register for SATA ports 0, 1, 2, and 3 respectively. Refer to Table 116, "SU PCI DPA Interrupt Pending Register - SUPDIPR" on page 194.</p>
09	<p>ERR_C - Non-Recovered Communication:</p> <p>When set to one, this bit indicates that there is no signal detected on the PHY receive path (RX). This may occur from a faulty interconnect or the device has been removed. This bit is cleared by writing a 1 to it.</p> <p>The default value after reset is 0₂. After reset, when a signal is not detected on the receive path (RX pair), the value will change to 1₂. After detecting a signal on the receive line, this bit will then change to 0₂.</p>
08	<p>ERR_T - Non-Recovered Transient Data Integrity Error:</p> <p>This bit indicates that either a CRC error, disparity error, or the receipt of an R_ERR primitive occurred in response to a Data FIS. This bit is cleared by writing a 1 to it. This bit is reported as an interrupt on bit 5, 13, 21, and 29 of the SATA Interrupt Pending register for SATA ports 0, 1, 2, and 3 respectively. Refer to Table 116, "SU PCI DPA Interrupt Pending Register - SUPDIPR" on page 194.</p>
07:02	Reserved
01	<p>ERR_M - Recovered Communications Error:</p> <p>This bit indicates that the PHY went from not ready-to-ready. This bit shall remain cleared when the PHY was not detected as ready during the initialization process. When the PHY goes ready after initialization, this bit shall transition to 1. This bit is cleared by writing a 1 to it. This bit is reported as an interrupt on bit 1, 9, 17, and 25 of the SATA Interrupt Pending register for SATA ports 0, 1, 2, and 3 respectively. Refer to Table 116, "SU PCI DPA Interrupt Pending Register - SUPDIPR" on page 194.</p> <p>The default value after reset is 0₂, for example the PHY will not be ready. When the PHY becomes ready as part of the initialization sequence, the value will change to 1₂.</p>
00	ERR_I - Reserved, not implemented.

5.8 SATA Port Interrupt Generation

When the SATA Unit on the GD31244 controller is in PCI IDE mode, interrupts that are generated follow the ATA standard. An ATA device generates an interrupt using the INTRQ hardware signal during normal data transfer to indicate data transfer completion and/or to indicate an error condition. An error condition is indicated when the ERR bit (bit 0) in the Status register is set. In contrast, a SATA device indicates an interrupt by using the 'I' bit (a pseudo INTRQ signal) in the PIO Setup FIS, or the Device-to-Host Register FIS. A hardware interrupt is then generated based on the 'I' being set.

When the SATA Unit operates in PCI DPA Mode, interrupts may also be generated by bits being set in the SATA SError Registers, in addition to the normal ATA standard interrupts explained above. Refer to [Table 136, "SU PCI DPA SATA SError Register - SUPDSSER" on page 222](#), and [Table 116, "SU PCI DPA Interrupt Pending Register - SUPDIPR" on page 194](#).

The block diagram in [Figure 31](#) shows how each SATA Unit generates and posts interrupts coming from the SATA ports. SATA Unit posted interrupts are routed onto PCI interrupt line - PINTA#.

Interrupts may also be generated using Message-Signaled Interrupts. Refer to [Section 5.9, "Message-Signaled Interrupts" on page 102](#). When MSI is enabled, the GD31244 controller will not generate interrupts using the interrupt line - PINTA#.

Figure 31. SATA Unit Interrupt Generation Block Diagram

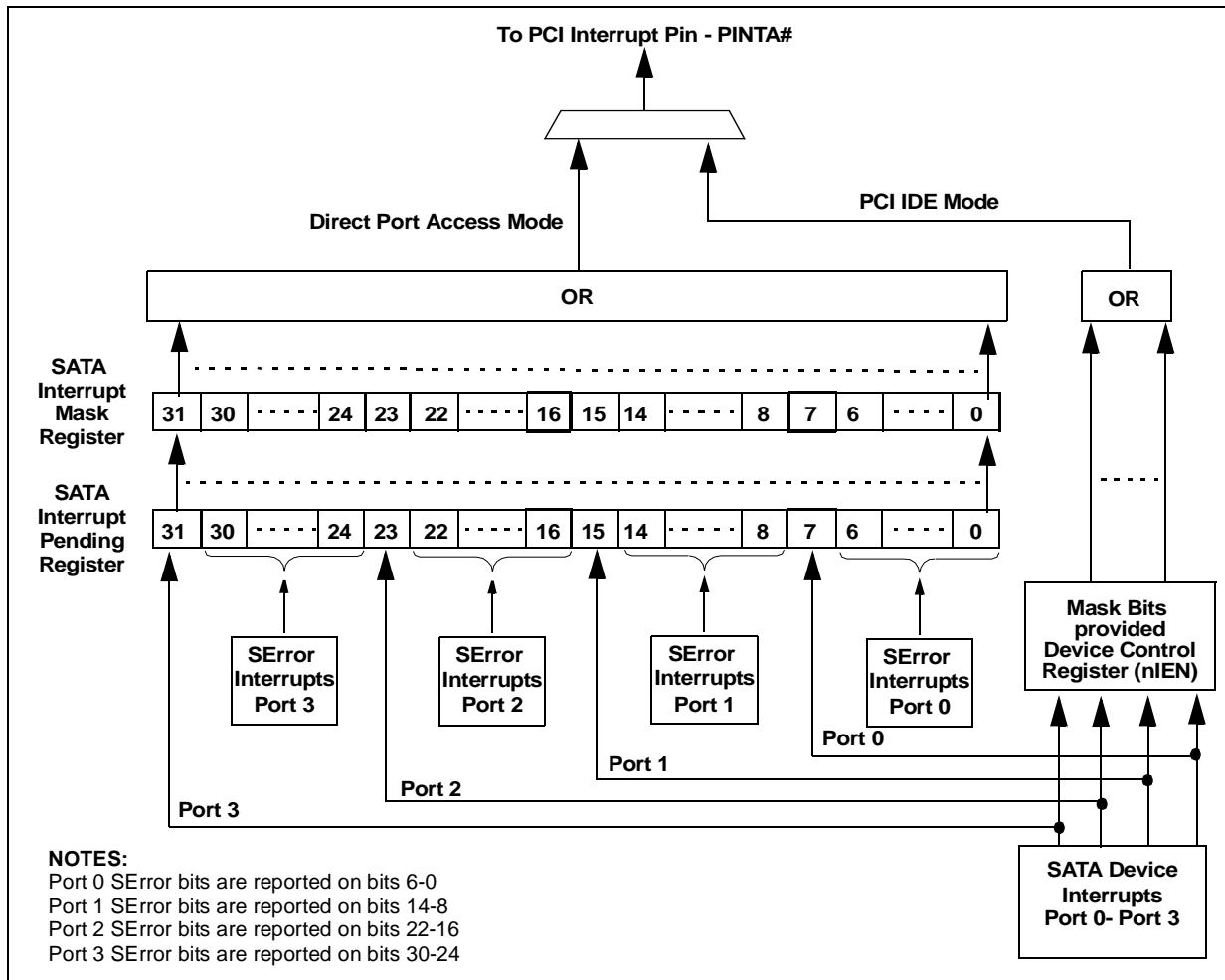

5.9 Message-Signaled Interrupts

The GD31244 controller may deliver interrupt to the Host Processor through the **P_INTA#** output pin or the Message-Signaled Interrupt (MSI) mechanism.

When a host processor enables Message-Signaled Interrupts (MSI) on the GD31244 controller, a SATA Unit interrupt will be signaled to the host through a PCI write instead of the assertion of the **P_INTA#** output pin.

PCI-X Addendum to the PCI Local Bus Specification, Revision 1.0a states: “PCI-X devices that generate interrupts are required to support message-signaled interrupts, as defined by the *PCI Local Bus Specification*, Revision 2.2 and must support a 64-bit message address.” “Devices that require interrupts in systems that do not support message-signaled interrupts, must implement interrupt pins.” Thus, the GD31244 controller needs to implement both wired and message-signaled interrupt delivery mechanisms.

In support of MSI, the GD31244 controller will implement the MSI capability structure. The capability structure includes the “[SU MSI Message Control Register - SUMSI_Message_Control](#)” on page 162, the “[SU MSI Message Address Register - SUMSI_Message_Address](#)” on page 163, the “[SU MSI Message Upper Address Register - SUMSI_Message_Upper_Address](#)” on page 164 and the “[SU MSI Message Data Register - SUMSI_Message_Data](#)” on page 165.

During system initialization, the configuration software for an MSI system will read the Message Control Register to determine that the GD31244 controller supports a 64-bit Message Address, and that it is capable of generating four unique interrupt messages.

After gathering this data from all of the MSI capable devices in the system, the configuration software will decide where to initialize the Message Address and how many unique messages each MSI capable device is allowed. Then, software will write the Message Address Registers (and the Message Upper Address Registers when Message Address is above the 4G address boundary¹), and the Message Data Register. This system specified data will be used to route the interrupt request message to the appropriate entry in a host processor Local APIC table.

Configuration of MSI completes with a write to the Message Control Register which includes an update to the Multiple Message Enable field and the MSI enable bit of each device. This will inform the device how many unique messages (Local APIC table entries) have been allocated for exclusive use by that device and enable that device for MSI. Device hardware is required to handle allocation of fewer unique interrupt messages than requested by the Multiple Message Capable field.

The GD31244 controller may generate up to four messages - one per SATA port, but it is also able to generate less than four messages - two or one message. Interrupt handler software needs to read the SATA port status and interrupt pending registers to determine the cause of the interrupt when more than one SATA ports are represented by less than four MSI messages.

Note: When host software enables MSI, the interrupt will not result in the assertion of the **P_INTA#** output pin.

5.9.1 Level-Triggered Versus Edge-Triggered Interrupts

When MSI is disabled, the **P_INTA#** pin remains asserted and pended to the host when **any** of the SATA Unit interrupt sources requires service. Since the PCI pin signaled interrupt is **level-triggered**, the interrupt service routine will not drop out of the service routine until the interrupt signal is deasserted. This will ensure that an interrupt will not be missed.

MSI interrupts are inherently edge-triggered, in that an interrupt is only pended to the host as a write event when any of the SATA Port requires service.

1. When host software writes the Message Upper address register to a non-zero value, device hardware will use a write transaction with a Dual Address Cycle (DAC) to present the full 64-bit address to the bus.

5.10 Register Definitions

The section is broken into three subsections. Each subsection describes a different programming interface.

- PCI IDE Mode Registers
- Direct Port Access Mode Registers

5.10.1 PCI IDE Mode Registers

This section defines the SATA port registers as viewed from the PCI bus when in PCI IDE mode

Every PCI device/function implements its own separate configuration address space and configuration registers. The *PCI Local Bus Specification*, Revision 2.2 requires that configuration space be 256 bytes, and the first 64 bytes must adhere to a predefined header format.

Figure 32 defines the header format. Table 35 shows the PCI configuration registers. Table 35 shows the entire Serial ATA Unit configuration space (including header and extended registers) and the corresponding section that describes each register.

Figure 32. SU in PCI IDE Mode Interface Configuration Header Format

Device ID		Vendor ID		00H
Status		Command		04H
Class Code			Revision ID	08H
BIST	Header Type	Latency Timer	Cacheline Size	0CH
Base Address 0				10H
Base Address 1				14H
Base Address 2				18H
Base Address 3				1CH
Base Address 4				20H
Base Address 5				24H
Reserved				28H
Subsystem ID		Subsystem Vendor ID		2CH
Expansion ROM Base Address				30H
Reserved			Capabilities Pointer	34H
Reserved				38H
Maximum Latency	Minimum Grant	Interrupt Pin	Interrupt Line	3CH

The Serial ATA Unit is programmed through a Type 0 configuration command on the PCI interface. Serial ATA Unit (SU) configuration space is function number zero.

Beyond the required 64-byte header format, Serial ATA Unit configuration space implements extended register space in support of the unit functionality. Refer to the *PCI Local Bus Specification*, Revision 2.2 for details on accessing and programming configuration register space.

The Serial ATA Unit includes two 8 byte and one 16-byte extended capability configuration spaces beginning at configuration offset E0H, E8H and F0H. The extended configuration spaces may be accessed by a device on the PCI interface through a mechanism defined in the *PCI Local Bus Specification*, Revision 2.2.

In the SU Status Register (Section 5.10.2.4) the appropriate bit is set indicating that the Extended Capability Configuration space is supported. When this bit is read, the device may then read the Capabilities Pointer register (Section 5.10.2.20) to determine the configuration offset of the Extended Capabilities Configuration Header. The format of these headers are depicted in Figure 33 through Figure 35.

Figure 33. SATA Unit Interface Extended Configuration Header Format (PCI-X Capability)

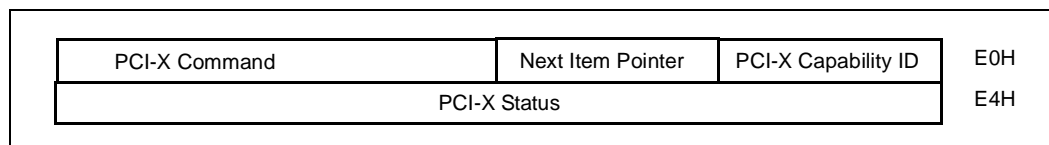

The first byte at the Extended Configuration Offset E0H is the PCI-X Capability Identifier Register (Section 5.10.2.42). This will identify this Extended Configuration Header space as the type defined by the *PCI-X Addendum to the PCI Local Bus Specification*, Revision 1.0a.

Following the Capability Identifier Register will be the single byte Next Item Pointer Register (Section 5.10.2.43) which will indicate the configuration offset of an additional Extended Capabilities Header, when supported. In the SATA Unit, the Next Item Pointer Register is set to E8H indicating that there are additional Extended Capabilities Headers supported in the SATA Unit configuration space.

Figure 34. SU in PCI IDE Mode Interface Extended Configuration Header Format (Power Management)

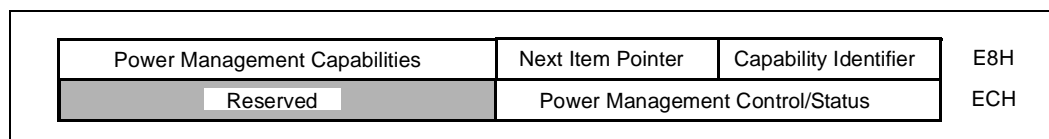

The first byte at the Extended Configuration Offset E8H is the SATA Unit Capability Identifier Register (Section 5.10.2.46). This will identify this Extended Configuration Header space as the type defined by the *PCI Bus Power Management Interface Specification*, Revision 1.1.

Following the Capability Identifier Register will be the single byte Next Item Pointer Register (Section 5.10.2.47) which will indicate the configuration offset of an additional Extended Capabilities Header, when supported. In the Serial ATA Unit, the Next Item Pointer Register is set to F0H indicating that there are additional Extended Capabilities Headers supported in the Serial ATA Unit configuration space.

It is the configuration software responsibility to properly enable and initialize the SATA Unit Power Management Interface.

Figure 35. SU in PCI IDE Mode Interface Extended Configuration Header Format (MSI Capability)

MSI Message Control	MSI Next Item Pointer	MSI Capability ID	F0H
MSI Message Address			F4H
MSI Message Upper Address			F8H
Reserved	MSI Message Data		FCH

The first byte at the Extended Configuration Offset F0H is the MSI Capability Identifier Register (Section 5.10.2.50). This will identify this Extended Configuration Header space as the type defined by the *PCI Local Bus Specification*, Revision 2.2.

Following the Capability Identifier Register will be the single byte Next Item Pointer Register (Section 5.10.2.51) which will indicate the configuration offset of an additional Extended Capabilities Header, when supported. In the SATA Unit, the Next Item Pointer Register is set to 00H indicating that there is no additional Extended Capabilities Headers supported in the SATA Unit configuration space.

The following sections describe the Serial ATA Unit configuration registers. Configuration space consists of 8-, 16-, 24-, and 32-bit registers arranged in a predefined format. Each register is described in functionality, access type (read/write, read/clear, read only) and reset default condition.

See Section 1.2, “Terminology and Conventions” on page 16 for a description of *reserved*, *read only*, and *read/clear*. All registers adhere to the definitions found in the *PCI Local Bus Specification*, Revision 2.2 unless otherwise noted.

The PCI register number for each register is given in Table 35. As stated, a Type 0 configuration command on the bus with an active **IDSEL**.

Table 35. SATA Unit PCI Configuration Space Registers (Sheet 1 of 2)

Register Name	Bits	PCI Configuration Cycle Register #	Offset
SU Vendor ID Register - SUVID	16	0	00H
SU Device ID Register - SUDID	16	0	02H
SU Command Register - SUCMD	16	1	04H
SU Status Register - SUSR	16	1	06H
SU Revision ID Register - SURID	8	2	08H
SU Class Code Register - SUCCR	24	2	09H
SU Cacheline Size Register - SUCLSR	8	3	0CH
SU Latency Timer Register - SULT	8	3	0DH
SU Header Type Register - SUHTR	8	3	0EH
SU BIST Register - SUBISTR	8	3	0FH
SU Base Address Register 0 - SUBAR0	32	4	10H
SU Base Address Register 1 - SUBAR1	32	5	14H
SU Base Address Register 2 - SUBAR2	32	6	18H
SU Base Address Register 3 - SUBAR3	32	7	1CH
SU Base Address Register 4 - SUBAR4	32	8	20H
SU Base Address Register 5 - SUBAR5	32	9	24H
Reserved.	32	10	28H
SU Subsystem Vendor ID Register - SUSVIR	16	11	2CH
SU Subsystem ID Register - SUSIR	16	11	2EH
SU Expansion ROM Base Address Register - SUEXROMBAR.	32	12	30H
SU Capabilities Pointer Register - SU_Cap_Ptr	8	13	34H
Reserved.	24	13	35H
Reserved.	32	14	38H
SU Interrupt Line Register - SUILR	8	15	3CH
SU Interrupt Pin Register - SUIPR	8	15	3DH
SU Minimum Grant Register - SUMGNT	8	15	3EH
SU Maximum Latency Register - SUMLAT	8	15	3FH
Reserved.	32	16	40H
Reserved.	32	17	44H
Reserved.	32	18	48H
Reserved.	24	19	4CH
Reserved.	8	19	4FH
Reserved.	32	20	50H
Reserved.	32	21	54H
Reserved.	32	22	58H
Reserved.	32	23	5CH
Reserved.	32	24	60h
Reserved.	32	25	64H
Reserved.	32	26	68H
Reserved.	32	27	6CH
Reserved.	32	28	70H
Reserved.	32	29	74H
Reserved.	32	30	78H
Reserved.	32	31	7CH
Reserved.	32	32	80H

Table 35. SATA Unit PCI Configuration Space Registers (Sheet 2 of 2)

Register Name	Bits	PCI Configuration Cycle Register #	Offset
Reserved.	32	33	84H
Reserved.	32	34	88H
Reserved.	32	35	8CH
SPI Command Register - SPICMDR	8	36	90H
SPI Control Register - SPICNTR	8	36	91H
SPI Status Register - SPISTATR	8	36	92H
Reserved.	8	36	93H
SPI Data Register - SPIDATR	32	37	94H
Reserved.	16	37	96H
SU Extended Control and Status Register 0 - SUECSR 0	32	38	98H
Reserved.	32	39	9CH
SU DMA Control Status Register- SUDCSCR	32	40	A0H
SU Dummy Register SUDR	32	41	A4H
SU Interrupt Status Register SUI SR	32	42	A8H
SU Interrupt Mask Register SUIMR	32	43	ACH
Reserved.	32	44	B0H
Reserved.	32	45	B4H
Reserved.	32	46	B8H
Reserved.	32	47	BCH
SU Transaction Control SUTCR	32	48	C0H
SU Target Split Completion Message Enable Register SUTSCMER	32	49	C4H
SU Target Delayed/Split Request Pending Register SUDRPR	32	50	C8H
SU Transaction Control 2 Register SUTC2R	32	51	CCH
SU Master Deferred/Split Sequence Pending Register - SUMDSPR	32	52	D0H
SU Master Split Completion Message Received with Error Message Register - SUMSCMREMR	32	53	D4H
SU Arbiter Control - SUACR	32	54	D8H
Reserved.	32	55	DCH
SU PCI-X_Capability Identifier Register - SUPCI-X_Cap_ID	8	56	E0H
SU PCI-X Next Item Pointer Register - SUPCI-X_Next_Item_Ptr	8	56	E1H
SU PCI-X Command Register - SUPCIXCMD	16	56	E2H
SU PCI-X Status Register - SUPCIXSR	32	57	E4H
SU PM_Capability Identifier Register - SUPM_Cap_ID	8	58	E8H
SU PM Next Item Pointer Register - SUPM_Next_Item_Ptr	8	58	E9H
SU Power Management Capabilities Register - SUPMCR	16	58	EAH
SU Power Management Control/Status Register - SUPMCSR	16	59	ECH
Reserved.	16	59	EEH
SU MSI Capability Identifier Register - SUMSI_Cap_ID	8	60	F0H
SU MSI Next Item Pointer Register - SUMSI_Next_Ptr	8	60	F1H
SU MSI Message Control Register - SUMSI_Message_Control	16	60	F2H
SU MSI Message Address Register - SUMSI_Message_Address	32	61	F4H
SU MSI Message Upper Address Register - SUMSI_Message_Upper_Address	32	62	F8H
SU MSI Message Data Register - SUMSI_Message_Data	16	63	FCH

Table 36. SATA Command Block Registers in PCI IDE Mode

Register Name	Bits	Access	BAR 0/2 + Offset
SU IDE Data Port Register - SUIDR	16	Read/Write	00H
SU IDE Error Register - SUIER	8	Read Only	01H
SU IDE Features Register - SUIFR	8	Write Only	01H
SU IDE Sector Count Register - SUISCR	8	Read/Write	02H
SU IDE Sector Number Register - SUISNR	8	Read/Write	03H
SU IDE Cylinder Low Register - SUICLR	8	Read/Write	04H
SU IDE Cylinder High Register - SUICHR	8	Read/Write	05H
SU IDE Device/Head Register - SUIDHR	8	Read/Write	06H
SU IDE Status Register - SUIISR	8	Write Only	07H
SU IDE Command Register - SUICR	8	Read Only	07H

NOTE: In Native-PCI mode, the offset is relative to the PCI Base Address Registers at offset 10H and 18H in the PCI Configuration Space. Base Address Register at offset 10H points to Channel 0. And Base Address Register at offset 18H points to Channel 1.

Table 37. SATA Control Block Registers in PCI IDE Mode

Register Name	Bits	Access	BAR 0/2 + Offset
Reserved.	8		00H
Reserved.	8		01H
SU IDE Device Control Register - SUIDCR	8	Write Only	02H
SU IDE Alternate Status Register - SUIASR	8	Read Only	02H
Reserved.	8		03H

NOTE: In Native-PCI mode, the offset is relative to the PCI Base Address Registers at offset 14H and 1CH in the PCI Configuration Space. Base Address Register at offset 14H points to Channel 0. And Base Address Register at offset 1CH points to Channel 1.

Table 38. SATA DMA Registers in PCI IDE Mode

Register Name	Bits	Offset
SU IDE Channel 0 DMA Command Register - SUICDCR0	8	00H
Reserved	8	01H
SU IDE Channel 0 DMA Status Register - SUICDSR0	8	02H
Reserved	8	03H
SU IDE Channel 0 DMA Descriptor Table Pointer Register - SUICDDTPR0	32	04H
SU IDE Channel 1 DMA Command Register - SUICDCR1	8	08H
Reserved	8	09H
SU IDE Channel 1 DMA Status Register - SUICDSR1	8	0AH
Reserved	8	0BH
SU IDE Channel 1 DMA Descriptor Table Pointer Register - SUICDDTPR1	32	0CH

NOTE: The offset is relative to the PCI Base Address Register at offset 20H in the PCI Configuration Space.

5.10.2 PCI Configuration Registers

This section defines the PCI configuration registers.

5.10.2.1 SU Vendor ID Register - SUVID

SU Vendor ID Register bits adhere to the definitions in the *PCI Local Bus Specification*, Revision 2.2.

Table 39. SU Vendor ID Register - SUVID

<p>PCI Configuration Address Offset 00H - 01H</p>		
<p>Attribute Legend: RV = Reserved PR = Preserved RS = Read/Set</p>		
<p>RW = Read/Write RC = Read Clear RO = Read Only NA = Not Accessible</p>		
Bit	Default	Description
15:00	8086H	SU Vendor ID - This is a 16-bit value assigned to Intel. This register, combined with the DID, uniquely identify the PCI device. Access type is Read/Write to allow the GD31244 controller to configure the register as a different vendor ID to simulate the interface of a standard mechanism currently used by existing application software.

5.10.2.2 SU Device ID Register - SUDID

SU Device ID Register bits adhere to the definitions in the *PCI Local Bus Specification*, Revision 2.2.

Table 40. SU Device ID Register - SUDID

<p>PCI Configuration Address Offset 02H - 03H</p> <p>Attribute Legend: RV = Reserved PR = Preserved RS = Read/Set RW = Read/Write RC = Read Clear RO = Read Only NA = Not Accessible</p>		
Bit	Default	Description
15:00	3200H	SU Device ID - This is a 16-bit value assigned to the SATA Unit. This ID, combined with the VID, uniquely identify any PCI device.

5.10.2.3 SU Command Register - SUCMD

SU Command Register bits adhere to the definitions in the *PCI Local Bus Specification*, Revision 2.2 and in most cases, affect the behavior of the PCI SU and devices on the PCI bus.

Table 41. SU Command Register - SUCMD

Bit	Default	Description
15:10	000000 ₂	Reserved
09	0 ₂	Fast Back to Back Enable - When cleared, the SATA Unit interface is not allowed to generate fast back-to-back cycles on its bus. Ignored when operating in the PCI-X mode.
08	0 ₂	SERR# Enable - When cleared, the SATA Unit interface is not allowed to assert SERR# on the PCI interface.
07	0 ₂	Address/Data Stepping Control - The SATA Unit does not support address stepping.
06	0 ₂	Parity Error Response - When set, the SATA Unit takes normal action when a parity error is detected. When cleared, parity checking is disabled.
05	0 ₂	VGA Palette Snoop Enable - The SATA Unit interface does not perform VGA palette snooping.
04	0 ₂	Memory Write and Invalidate Enable - When set, SATA Unit may generate MWI commands. When clear, SATA Unit use Memory Write commands instead of MWI. Ignored when operating in the PCI-X mode.
03	0 ₂	Special Cycle Enable - The SATA Unit interface does not respond to special cycle commands in any way. Not implemented and a reserved bit field.
02	0 ₂	Bus Master Enable - The SATA Unit interface may act as a master on the PCI bus. When cleared, disables the device from generating PCI accesses. When set, allows the device to behave as a PCI bus master.
01	0 ₂	Memory Enable - Controls the SATA Unit response to PCI memory addresses. When cleared, the SATA Unit does not respond to any memory access on the PCI bus. The SATA port registers are memory-mapped in DPA mode.
00	0 ₂	I/O Space Enable - Controls the SATA Unit response to I/O transaction. When cleared, the SATA Unit does not respond to I/O access on the PCI Bus. The SATA Port registers are I/O-mapped in PCI IDE mode.

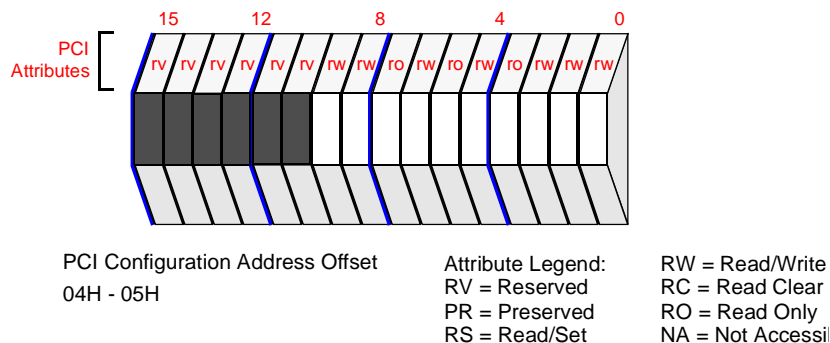

5.10.2.4 SU Status Register - SUSR

The SU Status Register bits adhere to the *PCI Local Bus Specification*, Revision 2.2 definitions. The *read/clear* bits may only be set by internal hardware and cleared by either a reset condition or by writing a 1₂ to the register.

Table 42. SU Status Register - SUSR

Bit	Default	Description
15	0 ₂	Detected Parity Error - set when a parity error is detected in data received by the SATA Unit on the PCI bus even when the SUCMD register Parity Error Response bit is cleared. Set under the following conditions: <ul style="list-style-type: none"> Write Data Parity Error when the SATA Unit is a target (inbound write). Read Data Parity Error when the SATA Unit is a requester (outbound read). Any Address or Attribute (PCI-X Only) Parity Error on Bus (including one generated by SATA Unit).
14	0 ₂	SERR# Asserted - set when SERR# is asserted on the PCI bus by the SATA Unit.
13	0 ₂	Master Abort - set when a transaction initiated by the SATA Unit PCI master interface, ends in a Master-Abort or when the SATA Unit receives a Master Abort Split Completion Error Message in PCI-X mode.
12	0 ₂	Target Abort (master) - set when a transaction initiated by the SATA Unit PCI master interface, ends in a target abort or when the SATA Unit receives a Target Abort Split Completion Error Message in PCI-X mode.
11	0 ₂	Target Abort (target) - set when the SATA Unit interface, acting as a target, terminates the transaction on the PCI bus with a target abort.
10:09	01 ₂	DEVSEL# Timing - These bits are read-only and define the slowest DEVSEL# timing for a target device in Conventional PCI Mode regardless of the operating mode (except configuration accesses). 00 ₂ = Fast 01 ₂ = Medium 10 ₂ = Slow 11 ₂ = Reserved The SATA Unit interface uses Medium timing.
08	0 ₂	Master Parity Error - The SATA Unit interface sets this bit under the following conditions: <ul style="list-style-type: none"> The SATA Unit asserted PERR# itself or the SATA Unit observed PERR# asserted. And the SATA Unit acted as the requester for the operation in which the error occurred. And the SUCMD register Parity Error Response bit is set
07	1 ₂ (Conventional mode) 0 ₂ (PCI-X mode)	Fast Back-to-Back - The SATA Unit interface is capable of accepting fast back-to-back transactions in Conventional PCI mode when the transactions are not to the same target. Since fast back-to-back transactions do not exist in PCI-X mode, this bit will be forced to 0 in the PCI-X mode.
06	0 ₂	UDF Supported - User Definable Features are not supported
05	1 ₂	66 MHz. Capable - 66 MHz operation is supported.
04	1 ₂	Capabilities - When set, this function implements extended capabilities.
03:00	00000 ₂	Reserved.

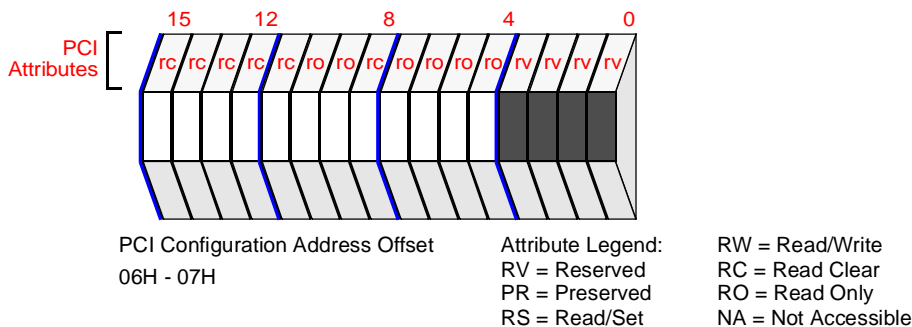

5.10.2.5 SU Revision ID Register - SURID

Revision ID Register bit definitions adhere to *PCI Local Bus Specification*, Revision 2.2.

Table 43. SU Revision ID Register - SURID

PCI Configuration Address Offset 08H		
Attribute Legend:		
RV = Reserved RW = Read/Write PR = Preserved RC = Read Clear RS = Read/Set RO = Read Only NA = Not Accessible		
Bit	Default	Description
07:00	00H	SU Revision - identifies the GD31244 controller revision number.

5.10.2.6 SU Class Code Register - SUCCR

Class Code Register bit definitions adhere to *PCI Local Bus Specification*, Revision 2.2. Auto configuration software reads this register to determine the PCI device function.

Table 44. SU Class Code Register - SUCCR

Bit	Default	Description
23:16	01H	Base Class - Mass Storage Device
15:08	Varies with external state of DPA_MODE# pin	Sub Class - <ul style="list-style-type: none"> When in Direct Port Access Mode (DPA_MODE# = low) = 06H - DPA Mode When in PCI IDE Mode (DPA_MODE# = high) = 01H - PCI IDE
07:04	Varies with external state of DPA_MODE# pin	Programming Interface - <ul style="list-style-type: none"> When in Direct Port Access Mode (DPA_MODE# = low) = 0000₂ When in PCI IDE Mode (DPA_MODE# = high) = 1000₂ - Bit 7 set identifies the PCI IDE device as a Bus Master
03:00	Varies with external state of DPA_MODE# pin	Programming Interface - <ul style="list-style-type: none"> When in Direct Port Access Mode (DPA_MODE# = low) = 0000₂ When in PCI IDE Mode (DPA_MODE# = high) = 0101₂ - SATA Unit supports Native-PCI mode only

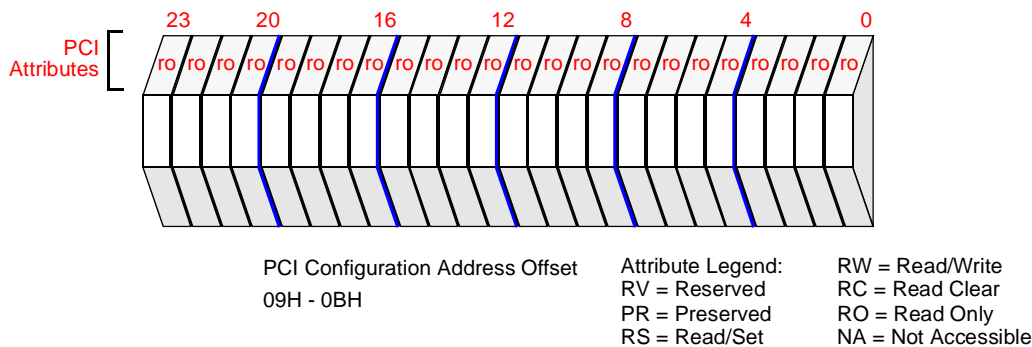

5.10.2.7 SU Cacheline Size Register - SUCLSR

Cacheline Size Register bit definitions adhere to *PCI Local Bus Specification, Revision 2.2*. This register is programmed with the system cacheline size in DWORDs (32-bit words). The GD31244 controller may burst up to a maximum of 512 bytes per request. The Cacheline Size register defines burst boundaries for bus master/DMA transactions generated by the GD31244 controller. For example, when a DMA transaction starts on a non-aligned cacheline address, the DMA controller starts the transaction by bursting from that unaligned address until the next cacheline boundary is reached. Subsequent DMA transactions then starts on cacheline boundaries and burst up to a maximum of 512 bytes. A value of zero means that burst transactions takes place on unaligned boundaries, transferring up to 512 bytes.

Table 45. SU Cacheline Size Register - SUCLSR

Bit	Default	Description	
07:00	00H	SU Cacheline Size - CLS specifies the system cacheline size in DWORDs.	
		CLS	Burst Length
		00	80h, 40h, 20h, 10h, 08h
		08	80h, 40h, 20h, 10h, 08h
		10	80h, 40h, 20h, 10h
		20	80h, 40h, 20h
		40	80h, 40h
		80	80h
		other	80h, 40h, 20h, 10h, 08h

5.10.2.8 SU Latency Timer Register - SULT

SU Latency Timer Register bit definitions apply to the PCI interface.

Table 46. SU Latency Timer Register - SULT

Bit	Default	Description
07:00	00H (Conventional Mode) 40H (PCI-X Mode)	Programmable Latency Timer - This field varies the latency timer for the interface from 0 to 248 clocks. The default value is 0 clocks for Conventional PCI mode, and 64 clocks for PCI-X mode.

PCI Configuration Address Offset
0DH

Attribute Legend:
 RV = Reserved RC = Read Clear
 PR = Preserved RO = Read Only
 RS = Read/Set NA = Not Accessible

5.10.2.9 SU Header Type Register - SUHTR

Header Type Register bit definitions adhere to *PCI Local Bus Specification*, Revision 2.2. This register indicates the layout of SATA Unit configuration space bytes 10H to 3FH. The MSB indicates whether or not the device is multi-function.

Table 47. SU Header Type Register - SUHTR

PCI Configuration Address Offset 0EH		
Attribute Legend: RW = Read/Write RV = Reserved PR = Preserved RS = Read/Set RC = Read Clear RO = Read Only NA = Not Accessible		
Bit	Default	Description
07	0_2	Single Function/Multi-Function Device - Identifies the GD31244 controller as a single-function PCI device.
06:00	000000_2	PCI Header Type - This bit field indicates the type of PCI header implemented. The SATA Unit interface header conforms to <i>PCI Local Bus Specification</i> , Revision 2.2.

5.10.2.10 SU BIST Register - SUBISTR

The SU BIST Register bit definitions adhere to *PCI Local Bus Specification*, Revision 2.2.

Table 48. SU BIST Register - SUBISTR

Bit	Default	Description
07	0 ₂	BIST Capable - This bit always returns a zero, meaning that this unit is not BIST capable.
06	0 ₂	Start BIST - Writing a one to this bit will invoke BIST. This bit will stay high until BIST is complete.
05:04	00 ₂	Reserved
03:00	0000 ₂	BIST Completion Code.

PCI Configuration Address Offset
0FH

Attribute Legend:

RW = Read/Write	RC = Read Clear
RV = Reserved	RO = Read Only
PR = Preserved	RS = Read/Set
RS = Read/Set	NA = Not Accessible

5.10.2.11 SU Base Address Register 0 - SUBAR0

The SU Base Address Register 0 (SUBAR0) defines the base I/O address of the Command Block Registers for Channel 0.

Table 49. SU Base Address Register 0 - SUBAR0

<p>PCI Configuration Address Offset 10H - 13H</p> <p>Attribute Legend: RV = Reserved RC = Read Clear PR = Preserved RS = Read/Set RW = Read/Write RO = Read Only NA = Not Accessible</p>		
Bit	Default	PCI IDE Description
31:00	0000_01F1H	Base Address 0 - These bits define the base address of the Command Block Registers in PCI I/O space for channel 0.
DPA Mode Description		
31:00	0000_0004H	Base Address 0 - 4K of memory for all port registers. Lower 32 bit address.

5.10.2.12 SU Base Address Register 1 - SUBAR1

The SU Base Address Register 1 (SUBAR1) defines the base I/O address of the Control Block Registers for Channel 0.

Table 50. SU Base Address Register 1 - SUBAR1

Bit	Default	PCI IDE Description
31:00	0000_03F5H	Base Address 1 - PCI IDE Mode: These bits define the base address of the Control Block Registers in PCI I/O space for channel 0.
DPA Mode		
31:00	0000_0000H	Base Address 1 - DPA Mode Upper 32 bits for BAR0

PCI Configuration Address Offset
14H - 17H

Attribute Legend:
 RW = Read/Write
 RV = Reserved
 PR = Preserved
 RS = Read/Set
 RC = Read Clear
 RO = Read Only
 NA = Not Accessible

5.10.2.13 SU Base Address Register 2 - SUBAR2

The SU Base Address Register 2 (SUBAR2) defines the base I/O address of the Command Block Registers for Channel 1.

Table 51. SU Base Address Register 2 - SUBAR2

Bit	Default	Description
31:04	0000_017H	Base Address 2 - These bits define the base address of the Command Block Registers in PCI I/O space for channel 1.
03	0 ₂	Base Address 2 - These bits define the base address of the Command Block Registers in PCI I/O space for channel 1.
02:01	00 ₂	Reserved.
00	1 ₂	I/O Space Indicator - This bit field describes memory or I/O space base address. The SATA Unit in PCI IDE mode is mapped into I/O space, thus this bit must be one.

PCI Configuration Address Offset
18H - 1BH

Attribute Legend:
 RV = Reserved RC = Read Clear
 PR = Preserved RO = Read Only
 RS = Read/Set NA = Not Accessible

5.10.2.14 SU Base Address Register 3 - SUBAR3

The SU Base Address Register 3 (SUBAR3) defines the base I/O address of the Control Block Registers for Channel 1.

Table 52. SU Base Address Register 3 - SUBAR3

Bit	Default	Description
31:04	0000_037H	Base Address 3 - These bits define the base address of the Control Block Registers in PCI I/O space for channel 1.
03:02	01 ₂	Base Address 3 - These bits define the base address of the Control Block Registers in PCI I/O space for channel 1.
01	0 ₂	Reserved.
00	1 ₂	I/O Space Indicator - This bit field describes memory or I/O space base address. The SATA Unit in PCI IDE mode is mapped into I/O space, thus this bit must be one.

5.10.2.15 SU Base Address Register 4 - SUBAR4

The SU Base Address Register 4 (SUBAR4) defines the base I/O address for the DMA functions for both channel 0 and 1.

Table 53. SU Base Address Register 4 - SUBAR4

Bit	Default	Description
31:04	0000_000H	Base Address 4 - These bits define the base address of the DMA Registers in PCI I/O space for both channel 0 and 1.
03:01	000 ₂	Reserved.
00	1 ₂	I/O Space Indicator - This bit field describes memory or I/O space base address. The SATA Unit in PCI IDE mode is mapped into I/O space, thus this bit must be one.

PCI Configuration Address Offset
20H - 23H

Attribute Legend:
 RW = Read/Write
 RV = Reserved
 PR = Preserved
 RS = Read/Set
 RC = Read Clear
 RO = Read Only
 NA = Not Accessible

5.10.2.16 SU Base Address Register 5 - SUBAR5

The SU Base Address Register 5 (SUBAR5) defines the base I/O address for the SATA superset registers. When in PCI IDE mode, the Superset registers for each SATA device on a given channel are selected by bit 4 (DEV bit) of the Command Block Device/Head register. The Primary and Secondary channel selection is done by writing bit 16 of the [SU Extended Control and Status Register 0 - SUECSR0](#). Refer to [Section 5.10.2.30, “SU Extended Control and Status Register 0 - SUECSR0”](#) on page 138.

In PCI IDE mode, the superset registers begins at offset 00H relative to this Base Address Register.

Table 54. SU Base Address Register 5 - SUBAR5

Bit	Default	Description
31:01	0000_0000H	Base Address 5 - These bits define the base address of the Superset Registers in PCI I/O address space.
00	1 ₂	I/O Space Indicator - This bit field describes memory or I/O space base address. The SATA Unit in PCI IDE mode is mapped into I/O space, thus this bit must be one.

PCI Configuration Address Offset
24H - 27H

Attribute Legend:
 RW = Read/Write
 RV = Reserved
 PR = Preserved
 RS = Read/Set
 RC = Read Clear
 RO = Read Only
 NA = Not Accessible

5.10.2.17 SU Subsystem Vendor ID Register - SUSVIR

SU Subsystem Vendor ID Register bit definitions adhere to *PCI Local Bus Specification*, Revision 2.2.

Table 55. SU Subsystem Vendor ID Register - SUSVIR

Bit	Default	Description
15:0	8086H	Subsystem Vendor ID - This register contains the same value as the SU Vendor ID register.

5.10.2.18 SU Subsystem ID Register - SUSIR

SU Subsystem ID Register bit definitions adhere to *PCI Local Bus Specification*, Revision 2.2.

Table 56. SU Subsystem ID Register - SUSIR

Bit	Default	Description
15:0	3200H	Subsystem ID - This register contains the same value as the SU Device ID register.

PCI Configuration Address Offset
2EH - 2FH

Attribute Legend:
 RW = Read/Write
 RV = Reserved
 RC = Read Clear
 PR = Preserved
 RO = Read Only
 RS = Read/Set
 NA = Not Accessible

5.10.2.19 SU Expansion ROM Base Address Register - SUEXROMBAR

The internal ROM controller performs an auto-detect function at the end of reset. If the external device is not detected, all bits in this register are LOW, effectively disabling the ROM memory space. This register conforms to the PCI spec for the expansion ROM interface. A read following a write of FFFF FFEh will return FFFE 0000h. This hardwired value indicates the presence of an external 128K x 8 Serial EEPROM. Firmware then writes a base address in bits [31:17] and the LSB is set to enable accesses. The ROM can then be accessed with PCI/PCI-X 32-bit memory transactions to the 128K byte space starting at the base address. The expansion ROM interface disconnects from data transfer after the first data phase of a burst read transaction, so burst transactions are valid but do not burst. Reads are performed through this port without the use of the SPI Configuration Registers. Writes are also performed through this port, but require proper use of the SPI Configuration Register. In PCI IDE mode, the superset registers begins at offset 00H relative to this Base Address Register.

The interface supports DWORD, word and byte accesses for both read and write transactions. The serial EEPROM device is an ST Microelectronics M25P10 or an Atmel AT25F1024. The EEPROM device's SPI registers can be accessed via the PCI configuration space (at 90h and 94h) and provides write enable, status, and erase commands. The device is read directly using the address of this BAR without having to use the SPI registers.

Table 57. SU Expansion ROM Base Address Register - SUEXROMBAR

PCI Configuration Address Offset
30H

Attribute Legend:
 RW = Read/Write
 RV = Reserved
 RC = Read Clear
 PR = Preserved
 RO = Read Only
 RS = Read/Set
 NA = Not Accessible

Bit	Default	Description
31:17	0000_0000H	Base address to access 128K x 8 ROM memory space..
16:	0000h	ROM Size Supported - 128 Kbytes (per PCI Specification)
00	0/1	ROM Space enable. Set to 1 to enable access. The reset value is 0h if an external EEPROM is not detected at power-up. The reset value is 1h if an external EEPROM is detected.

5.10.2.20 SU Capabilities Pointer Register - SU_Cap_Ptr

The Capabilities Pointer Register bits adhere to the definitions in the *PCI Local Bus Specification*, Revision 2.2. This register provides an offset in this function PCI Configuration Space for the location of the first item in the first Capability list. In the case of the GD31244 controller, this is the PCI-X Capability.

Table 58. SU Capabilities Pointer Register - SU_Cap_Ptr

36 Bit	Default	Description
07:00	E0H	Capability List Pointer - This provides an offset in this function configuration space that points to the GD31244 controller PCI-X Capability.

5.10.2.21 SU Expansion ROM Base Address - SUEXROM

The internal ROM controller performs an auto-detect function at the end of reset. If the external device is not detected, all bits in this register are LOW, effectively disabling the ROM memory space. This register conforms to the PCI spec for the expansion ROM interface. A read following a write of FFFF FFFEh will return FFFE 0000h. This hardwired value indicates the presence of an external 128K x 8 Serial EEPROM. Firmware then writes a base address in bits [31:17] and the LSB is set to enable accesses. The ROM can then be accessed with PCI/PCI-X 32-bit memory transactions to the 128K byte space starting at the base address. The expansion ROM interface disconnects from data transfer after the first data phase of a burst read transaction, so burst transactions are valid but do not burst. Reads are performed through this port without the use of the SPI Configuration Registers. Writes are also performed through this port, but require proper use of the SPI Configuration Register.

The interface supports DWORD, word and byte accesses for both read and write transactions. The serial EEPROM device is an ST Microelectronics M25P10 or an Atmel AT25F1024. The EEPROM device's SPI registers can be accessed via the PCI configuration space (at 90h and 94h) and provides write enable, status, and erase commands. The device is read directly using the address of this BAR without having to use the SPI registers.

Table 59. SU Expansion ROM Base Address - SUEXROM

36 Bit	Default	Description
31:17	0000_0000H	Base Address to access 128K x 8 ROM memory space.
16:1	0000	ROM Size Supported - 128Kbytes (per PCI spec)
0	0 or 1	ROM Space enable: Set to 1 to enable access. The reset value is 0h if an external EEPROM is not detected at the power-up. The reset value is 1h if an external EEPROM is detected.

PCI Configuration Address Offset
34H

Attribute Legend:
 RV = Reserved
 PR = Preserved
 RS = Read/Set
 RW = Read/Write
 RC = Read Clear
 RO = Read Only
 NA = Not Accessible

5.10.2.22 SU Interrupt Line Register - SUILR

SU Interrupt Line Register bit definitions adhere to *PCI Local Bus Specification*, Revision 2.2. This register identifies the system interrupt controller's interrupt request lines which connect to the device's PCI interrupt request lines (as specified in the interrupt pin register).

In a PC environment, for example, the register values and corresponding connections are:

- 0 (00H) through 15 (0FH) correspond to IRQ0 through IRQ15
- 16 (10H) through 254 (FEH) are reserved
- 255 (FFH) indicates unknown or no connection

The operating system or device driver may examine each device interrupt pin and interrupt line register to determine which system interrupt request line the device uses to issue requests for service.

Table 60. SU Interrupt Line Register - SUILR

Attribute Legend: RW = Read/Write RV = Reserved RC = Read Clear PR = Preserved RO = Read Only RS = Read/Set NA = Not Accessible		
Bit	Default	Description
07:00	0EH	Interrupt Assigned - system-assigned value identifies which system interrupt controller interrupt request line connects to the device's PCI interrupt request lines (as specified in the interrupt pin register).

5.10.2.23 SU Interrupt Pin Register - SUIPR

SU Interrupt Pin Register bit definitions adhere to *PCI Local Bus Specification*, Revision 2.2. This register identifies the interrupt pin the SATA Unit uses.

Table 61. SU Interrupt Pin Register - SUIPR

PCI Configuration Address Offset 3DH		Attribute Legend: RV = Reserved PR = Preserved RS = Read/Set RW = Read/Write RC = Read Clear RO = Read Only NA = Not Accessible
Bit	Default	Description
07:00	01H	Interrupt Used - This register tells which interrupt pin the SATA Unit uses. A value of 01H corresponds to INTA# .

5.10.2.24 SU Minimum Grant Register - SUMGNT

SU Minimum Grant Register bit definitions adhere to *PCI Local Bus Specification, Revision 2.2*. This register specifies the burst period the device requires in increments of eight PCI clocks.

This register and the SU Maximum Latency register are information-only registers which the configuration uses to determine how often a bus master typically requires access to the PCI bus and the duration of a typical transfer when it does acquire the bus. This information is useful in determining the values to be programmed into the bus master latency timers and in programming the algorithm to be used by the PCI bus arbiter.

Table 62. SU Minimum Grant Register - SUMGNT

Bit	Default	Description
07:00	10H	Minimum grant specifies, in 0.25 μ s increments, the minimum burst period the core needs. The core does not have any special MIN_GNT requirements. In general, the more channels active, the worse the bus latency and the shorter the burst cycle.

5.10.2.25 SU Maximum Latency Register - SUMLAT

SU Maximum Latency Register bit definitions adhere to *PCI Local Bus Specification, Revision 2.2*. This register specifies how often the device needs to access the PCI bus in increments of eight PCI clocks.

This register and the Minimum Grant Register are information-only registers which the configuration uses to determine how often a bus master typically requires access to the PCI bus and the duration of a typical transfer when it does acquire the bus. This information is useful in determining the values to be programmed into the bus master latency timers and in programming the algorithm to be used by the PCI bus arbiter.

Table 63. SU Maximum Latency Register - SUMLAT

Bit	Default	Description
07:00	01H	Maximum latency specifies how often the core needs to gain access to the PCI bus. The value is specified in 0.25 μ s increments and assumes a 33 MHz clock. A value of 0Fh means the core needs to gain access to the PCI bus every 130 PCI clocks, expressed as 3.75 μ s in this register.

5.10.2.26 SPI Command Register - SPICMDR

Serial Peripheral Interface (SPI) Command Register definition is described in Table 64. The host writes the command type to the command register after setting up the control and data registers as necessary. A write to this register initiates the command.

Table 64. SPI Command Register - SPICMDR

Bit	Default	Description
7:0	00	<p>Expansion Rom SPI interface command type. A write to this initiates the command. The status register bit D0 must be polled to determine when the command is complete.</p> <p>06h = WREN (write enable) 04h = WRDI (write disable) 01h = WRSR (write status) 02h = No action (SPI PROGRAM command) 52h = SECT_ERASE (sector erase) 62h = CHIP_ERASE (all sector erase) 05h = RDSR (read status) 03h = No action (SPI READ command) others = no action</p>

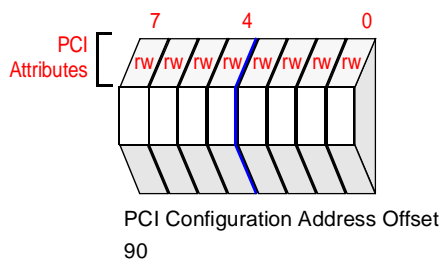

Attribute Legend:
 RW = Read/Write
 RV = Reserved
 PR = Preserved
 RS = Read/Set
 RC = Read Clear
 RO = Read Only
 NA = Not Accessible

5.10.2.27 SPI Control Register - SPICNTR

Serial Peripheral Interface (SPI) Control Register definition of this 8 bit register is described in Table 65. The host writes the control register to specify the sectors of the serial EEPROM to erase. Note that the set of all write pairs must be preceded by one of the two erase commands with the sectors specified in the control register.

Table 65. SPI Control Register - SPICNTR

Bit	Default	Description
15:10	00h	Reserved.
9:8	00b	Sector address [1:0]. Selects 1 of 4 sectors for the sector erase command 52h. It must be set prior or simultaneously with writing the SECT_ERASE command to the SPI Command Register.

5.10.2.28 SPI Status Register - SPISTATR

Serial Peripheral Interface (SPI) Status Register definition of this 8 bit register is described in Table 66. Writes to the serial device must be performed by a special device driver that polls the SPI Status Register to determine when the write is done. When HIGH indicates that the last command has been transferred to the serial prom successfully. A LOW indicates that the device is not ready.

Table 66. SPI Status Register - SPISTATR

Bit	Default	Description
23:17	00h	Reserved.
16	0b	Command done. When HIGH indicates that the last command has been communicated to the serial device. It does not mean the device is ready. The RDSR command must be issued to determine this.

PCI Configuration Address Offset
92

Attribute Legend:

RV = Reserved	RW = Read/Write
PR = Preserved	RC = Read Clear
RS = Read/Set	RO = Read Only
	NA = Not Accessible

5.10.2.29 SPI Data Register - SPIDATR

Serial Peripheral Interface (SPI) Data Register definition of this 32 bit register is described in Table 67. This is a multifunction register used by three commands. For the RDID command, it is a read-only register with manufacturer's id and device id in the upper and lower bytes respectively. For the WRSR/RDSR commands, lower byte is a write/read register with the above bit definitions. WPEN is not applicable if the serial EEPROM device has its write protect pin WPB inactive high. Refer to the serial EEPROM device specification for how to use these bits.

Table 67. SPI Data Register - SPIDATR

Bit	Default	Description
31:16	0000h	Reserved
15:8	00h	Device ID for the RDID command.
7:0		<p>This register contains data to be written to the EEPROM on a WRSR command and the data read from the EEPROM on RDSR and RDID commands. WRSR: Prior to a write of WRSR command to the SPI Command Register, this field should be written. Interpretation of these bits is as follows:</p> <ul style="list-style-type: none"> 7: WPEN - determines write protection state of the EEPROM with WEN 6: reserved, write as 0 5: reserved, write as 0 4: reserved, write as 0 3: BP1 - with BP0, selects the locked out sectors within the EEPROM. 2: BP0 - 00=No protection, 01=Sector 4 protected, 10=Sectors 3 & 4 protected, 11=All Sectors protected. 1: WEN - write as 0, this is a read-only bit in the EEPROM 0: RDY# - write as 0, this is a read-only bit in the EEPROM <p>RDSR: After completion of a RDSR command, this field contains the value of the EEPROMs Status Register. Interpretation of these bits is as follows:</p> <ul style="list-style-type: none"> 7: WPEN - determines write protection state of the EEPROM with WEN 6: reserved, LOW when the EEPROM is not in an internal write cycle 5: reserved, LOW when the EEPROM is not in an internal write cycle 4: reserved, LOW when the EEPROM is not in an internal write cycle 3-2: BP1-BP0 selects which EEPROM sectors are protected. 00=No Protection, 01= Sector 4 is protected, 10=Sectors 3&4 are protected, 11=Sectors 1-4 are protected. 1: WEN - determines write protection state of the EEPROM with WPEN 0: RDY# - RDID: After completion of a RDID command, this field contains the 8-bit Manufacturer ID as read from the EEPROM. For the Atmel AT25F1024, this should be 1Fh.

5.10.2.30 SU Extended Control and Status Register 0 - SUECSR0

This register is used to control the LED functionality and also to select the superset registers when in PCI IDE mode.

Table 68. SU Extended Control and Status Register 0 - SUECSR0

Bit	Default	Description
31:29	000 ₂	Reserved
28	1 ₂	LED0 Only: <ul style="list-style-type: none"> When this bit is set all SATA Ports' activity are reflected on LED0 only. Other LEDs are not used. In PCI IDE mode, when this bit is cleared, LED0 reflects the activity for Channel 0 (Port 0 and Port 1) and LED1 reflects the activity for Channel 1 (Port 2 and Port 3). In DPA mode, when this bit is cleared, LED0, LED1, LED2, and LED3 reflect the activity for Port 0, Port 1, Port 2, and Port 3 respectively.
27:17	000H	Reserved.
16	0 ₂	BAR 5 (Superset Features) Secondary Select: <ul style="list-style-type: none"> In PCI IDE mode this bit is a read/write bit and is used to select between the primary and secondary channel. When set, the secondary channel is selected. In DPA mode, this bit is a reserved bit.
15:03	0 ₂	Reserved.
02	0 ₂	Register protect. <ul style="list-style-type: none"> PCI IDE Mode: Register protect. Set this bit to 1 to enable writing the Device ID, Vendor ID, Class Code, Subclass Code, Interface Code registers and bits 27:24 and 1:0 of this register. Set to 0 to disable. DPA Mode: Register protect. Set this bit to 1 to enable writing the Device ID, Vendor ID, Class Code, Subclass Code, Interface Code registers and bits 27:24 and 1:0 of this register. Set to 0 to disable.
01	0 ₂	<ul style="list-style-type: none"> PCI IDE Mode: PCI clock domain reset. Write a 1 to this register to reset the host Clk domain. Write a 0 for normal operation. This bit is write protected by setting bit 2 and write enabled by clearing bit 2. DPA Mode: PCI clock domain reset. Write a 1 to this register to reset the hostClk domain. Write a 0 for normal operation. This bit is write protected by setting bit 2 and write enabled by clearing bit 2.
00	0 ₂	<ul style="list-style-type: none"> PCI IDE Mode: SATA clock domain reset. Write a 1 to this register to reset the sclk domain. Write a 0 for normal operation. This bit is write-protected by setting bit 2 and write enabled by clearing bit 2. DPA Mode: SATA clock domain reset. Write a 1 to this register to reset the sclk domain. Write a 0 for normal operation. This bit is write-protected by setting bit 2 and write enabled by clearing bit 2.

5.10.2.31 SU DMA Control Status Register- SUDCSCR

The control/status signals below are common to all four DMA channels or affect the Master Transaction Controller. Control/status signals that are individual to each port are contained in the Bus Master register set. See the description for the DMA Configuration register. Cache line alignment is enabled in the DMA write (from controller to memory) direction unless the Cache Line Size register is programmed with a value of 00h or an illegal value, in which case it is disabled. The burst length can only take values greater than the cache line size. If an illegal value is programmed for the burst length, the controller will internally use 40h for burst length, unless the cache line size is programmed for 80h, in which case the controller will use 80h. The burst length register is read/write and always returns the write value; if an illegal value is written, the corrected internal value will not be visible on read back. Cache line alignment is normally disabled in the DMA read direction. It may be enabled by setting bit 1.

Table 69. SU DMA Control Status Register - SUDCSCR 0

Bit	Default	Description
31:29	000 ₂	Reserved
28	1 ₂	Reserved
27	1	When HIGH, enables resets to the PCI/PCI-X core master transaction queue when bit 19 of the PCI-X Capability Status register is cleared. This is necessary to recover from split responses that never get completed due to a corrupted tag. Bit 19 of the PCI-X Capability Status register may also be set by an unexpected split completion due to a corrupted requester ID for a split transaction that is not initiated by this master. Clearing the queue in this case will not hurt even though the queue will have been correct. For test purposes only; set only when there is no PCI traffic.
26:16	0	Reserved
15:08	80h	DMA Burst Length: Bus master transaction burst length: This register contains the DMA burst length value in [15:8]. This value sets the nominal PCI transaction burst length, other conditions permitting. The resolution is 1 DWORD so the maximum in each case is 512 bytes and the minimum is 32 bytes. The descriptor table defines the length of each physical region using physical region descriptors. The Controller transfers each physical region in individual burst transactions.
07:03	0 ₂	• Reserved.
02	0 ₂	Block command disable. Set HIGH to disable the DMA engine from utilizing command types MWI and MRM in PCI mode only. This bit does not effect PCI-X mode.
01	0 ₂	DMA write cache align enable. When HIGH, the controller will align with the cacheline address before doing "burst length" transactions, total length permitting. When LOW, the controller will start with "burst length" transaction, regardless of start address, total length permitting.
00	0 ₂	DMA read cache align enable. When HIGH, the controller will align with the cacheline address before doing "burst length" transactions, total length permitting. When LOW, the controller will start with "burst length" transaction, regardless of start address, total length permitting.

5.10.2.32 SU Dummy Register SUDR

SU Dummy Register SUDR contains dummy Bits for scratchpad read/write.

Table 70. SU Dummy Register - SUDR

<p>PCI Configuration Address Offset A4 - A7</p> <p>Attribute Legend: RW = Read/Write RV = Reserved PR = Preserved RS = Read/Set RC = Read Clear RO = Read Only NA = Not Accessible</p>		
Bit	Default	Description
31:00	0000_0000h	Dummy bits for scratch pad reads and writes.

5.10.2.33 SU Interrupt Status Register SUI SR

This register reports interrupts generated by the SATA ports. Software must clear any pending interrupt at the appropriate sources. The IDE interrupts (bits 31, 23, 15, 7) are cleared by reading the SATA Port Command Block Status register. Other pending interrupts in this register are generated by the Superset Error registers and must be cleared by writing 1s to the Superset Error registers. These registers located in configuration space for PCI IDE mode and in the memory space for DPA mode.

Table 71. SU Interrupt Status Register - SUI SR

Bit	Default	PCI IDE Description
31:24	0	Port 4 Interrupt Status. Same as bits 7:0 corresponding to Port 4
23:16	0	Port 3 Interrupt Status. Same as bits 7:0 corresponding to Port 3
15:8	0	Port 2 Interrupt Status. Same as bits 7:0 corresponding to Port 3
7	0	Port 1 ATA Interrupt
6	0	Port 1 CRC Error. This is the latched CRC error from the previous data transfer.
5	0	Port 1 Data Integrity Error. A CRC or disparity error was detected by the host, or an RERR was returned by the device in response to a data FIS transfer.
4	0	Port 1 Unrecognized FIS Reception. An unrecognized FIS type was received.
3	0	Port 1 RERR Received. An RERR was received in response to a data transfer.
2	0	Port 1 FIFO Error. A FIFO error occurred during a data FIS transfer
1	0	Port 1 PHY went from Not-Ready to Ready steady state. The PHY became ready and OOB was completed.
0	0	Port 1 PHY Ready Change-Of-State. The PHY went from Ready to Not Ready or from Not-Read to Ready.
PCI DPA Mode Description		
31:00	0000_0000	Reserved - Note: Bits are Read Only in DPA mode

5.10.2.34 SU Interrupt Mask Register SUIMR

This register masks interrupts pending in the Interrupt Pending register. Each bit in the Interrupt Mask register corresponds to a bit in the Interrupt Pending register. Writing a one to a bit in this register enables the interrupt source bit. These registers located in configuration space in PCI IDE mode and in the common space in DPA mode. These registers are located in configuration space for PCI IDE mode and in the memory space for DPA mode.

Table 72. SU Interrupt Mask Register - SUIMR

Bit	Default	PCI IDE Description
31:24	0	Port 4 Interrupt Mask. Same as bits 7:0 corresponding to Port 4
23:16	0	Port 3 Interrupt Mask. Same as bits 7:0 corresponding to Port 3
15:8	0	Port 2 Interrupt Masks. Same as bits 7:0 corresponding to Port 3
7	0	Port 1 Interrupt Mask - when high enables Port 1 CRC Interrupts. When low Port 1 CRC Interrupts are disabled.
6	0	When high enables Port 1 CRC Error to generate and interrupt. When low this interrupt source is re disabled.
5	0	When high enables Port 1 Data Integrity Error to generate and interrupt. When low this interrupt source is disabled.
4	0	When high enables Port 1 Unrecognized FIS Reception Error to generate and interrupt. When low this interrupt source is disabled
3	0	When high enables Port 1 RERR Received Error to generate and interrupt. When low this interrupt source is disabled
2	0	When high enables Port 1 FIFO Error to generate and interrupt. When low this interrupt source is disabled
1	0	When high enables Port 1 Going Ready to generate and interrupt. When low this interrupt source is disabled.
0	0	When high enables Port 1 Going Ready to generate and interrupt. When low this interrupt source is disabled.
PCI DPA Mode Description		
31:00	0000_0000	Reserved

5.10.2.35 SU Transaction Control SUTCR

This register provides primary transaction control. The bits in the register should be set at reset values only.

Table 73. SU Transaction Control Register - SUTCR

Bit	Default	Description
31	0	Target read delayed transaction for I/O and non-prefetchable regions discarded. Write 1 to clear.
30	0	Target read delayed transaction for all regions discarded. Write 1 to clear.
29	0	Target (I/O and memory) read delayed/split at time out/immediately (default time out)
28	0	Target (I/O and memory) read delayed/split at time out/immediately (default time out)
27	0	Target (I/O and memory) read delayed /split or retry select (if application interface is not ready) 0 = delayed/split transaction 1 = retry transaction (always immediate retry, no AT_REQ to application)
26	0	Target (I/O and memory) read target abort enable (if application interface is not ready at the latency time out)
25	0	Target (I/O) write split enable (at time out/immediately; default time out)
24	0	Target (I/O) write split enable (if application interface is not ready)
23	0	Target (read/write) master abort enable; check at the start of each transaction.
22:20	0h	Target subsequent latency time out enable: 0 = 8, 1 to 7.
19:16	0	Target initial latency time-out in PCI mode: 0= 16, 8 to 15
15:4	000h	Programmable boundary enable to disconnect/prefetch for target burst read cycles to prefetchable region in PCI. A value of 1 indicates end of boundary (64KB down to 16 bytes).
3	0	Disconnect/prefetch to prefetchable memory regions enable. Prefetchable memory regions are always disconnected on a region boundary. Non-prefetchable regions for PCI are always disconnected on the first transfer.
2	0	Reserved
1	0	Target split write control 0 = blocks all requests except PMW 1 = blocks all requests including PMW until split completion occurs.
0	0	cr_lat_timer_disable

5.10.2.36 SU Target Split Completion Message Enable Register SUTSCMER

This register contains any split completion error messages received (SCM bit = 1 and SCE bit = 1). Bit 29 of the PCI configuration Status Register is set when a split completion error message is received.

Table 74. SU Target Split Completion Message Enable Register- SUTSCMER

Bit	Default	Description
31:0	0	Target read delayed transaction for I/O and non-prefetchable regions discarded. Write 1 to clear.

PCI Configuration Address Offset C4-C7

Attribute Legend:
 RV = Reserved
 PR = Preserved
 RS = Read/Set
 RW = Read/Write
 RC = Read Clear
 RO = Read Only
 NA = Not Accessible

5.10.2.37 SU Target Delayed/Split Request Pending Register SUDRPR

This register indicates if any target/delayed split request sequences are pending.

Table 75. SU Target Split Completion Message Enable Register- SUTSCMER

Bit	Default	Description
31:0	0	Target delayed/split request pending sequences.

PCI Configuration Address Offset
C8-CB

Attribute Legend:
RW = Read/Write
RV = Reserved
RC = Read Clear
PR = Preserved
RO = Read Only
RS = Read/Set
NA = Not Accessible

5.10.2.38 SU Transaction Control 2 Register SUTC2R

This register provides secondary transaction control.

Table 76. SU Transaction Control 2 Register- SUTC2R

Bit	Default	Description
31	1	Master request (memory read) byte count/byte enable select. <ul style="list-style-type: none"> • 0 = Byte enables valid. In PCI mode, a burst transaction cannot be performed using memory read command 6h. • 1 = DWORD byte count valid (default). In PCI mode, the memory read byte enables are automatically generated by the core.
30	0	Master request (I/O and CR cycles) byte count/byte enable select. <ul style="list-style-type: none"> • 0 = Byte enables valid • 1 = DWORD byte count valid.
29	0	Master (retry) deferred write enable (allows read requests to pass). PCI mode I/O and memory transactions only. <ul style="list-style-type: none"> • 0 = New read requests are not accepted until the current write cycle completes. Reads cannot pass writes. • 1 = New read requests are accepted, even when there is a write cycle pending. Reads can pass writes.
28	0	Master (retry) deferred read enable (allows read/write requests to pass.) PCI mode I/O and memory transactions only. <ul style="list-style-type: none"> • 0 = New read/write requests are not accepted until the current read cycle completes. Read/Write requests cannot pass reads. • 1 = New read/write requests are accepted, even when there is a read cycle pending. Read/write requests can pas reads.
27	0	Master I/O deferred/split request outstanding maximum count <ul style="list-style-type: none"> • 0 = CCh[26:24] • 1 = 1

Table 76. SU Transaction Control 2 Register- SUTC2R

Bit	Default	Description
26:24	010b	Master deferred read request outstanding max count. PCI mode only. Bits 26:24=000b, Max# SAC Cycles=8, Max# DAC Cycles=4 Bits 26:24=001b, Max# SAC Cycles=1, Max# DAC Cycles=0 Bits 26:24=010b, Max# SAC Cycles=2, Max# DAC Cycles=1 Bits 26:24=011b, Max# SAC Cycles=3, Max# DAC Cycles=1 Bits 26:24=100b, Max# SAC Cycles=4, Max# DAC Cycles=2 Bits 26:24=101b, Max# SAC Cycles=5, Max# DAC Cycles=2 Bits 26:24=110b, Max# SAC Cycles=6, Max# DAC Cycles=3 Bits 26:24=111b, Max# SAC Cycles=7, Max# DAC Cycles=3 For the PCI-X maximum outstanding split transactions, refer to crE0[22:20].
23:16	0000000b	Target/master error sequence number.
15	0	Target error command indication 0 = delayed/split 1 = others.
14	0	Target/master error indication 0 = target 1 = master
13	0	Target/master system error. This bit is set whenever ATM_SERR_O is active. Write one to clear.
12	0	Target/master data PERR# error status. This bit is set whenever ATM_DATA_PERR_O is active. Write one to clear.
11	0	Target/master address PERR# error status. This bit is set whenever ATM_ADD_PERR_O is active. Write one to clear.
10:9	00	Reserved.
8	0	Target illegal I/O DWORD byte combinations detected. Write one to clear.
7	0	Target illegal I/O DWORD byte detection ENABLE. Allows error to set SERR if SERR is enabled, also sets bit 8 above.
6	0	Reserved
5	0	Target I/O delayed split request outstanding maximum count: 0 = CCh[4:0] 1 = 1.
4:0	0001	Target delayed/split request outstanding maximum count: 0 = 32, 1 to 31.

5.10.2.39 SU Master Deferred/Split Sequence Pending Register - SUMDSPR

When a split completion error message is received (SCM bit = 1 and SCE bit = 1), the message value is written to this register. Bit 29 of the PCI-X Status Register is set when a split completion error message is received.

Table 77. SU Master Split Completion Message Received with Error Message Register - SUMSCMREMR

Bit	Default	Description
31:00	0000_0000H	Master deferred/split sequence pending.

PCI Attributes

PCI Configuration Address Offset
D0-D3H

Attribute Legend:
 RV = Reserved
 PR = Preserved
 RS = Read/Set
 RW = Read/Write
 RC = Read Clear
 RO = Read Only
 NA = Not Accessible

5.10.2.40 SU Master Split Completion Message Received with Error Message Register - SUMSCMREMR

When a split completion error message is received (SCM bit = 1 and SCE bit = 1), the message value is written to this register. Bit 29 of the PCI-X Status Register is set when a split completion error message is received.

Table 78. SU Master Split Completion Message Received with Error Message Register - SUMSCMREMR

Bit	Default	Description
31:00	0000_0000H	Split Completion Error Message Value - When a split completion error message (SCM bit = 1 and SCE bit = 1) is received, the message value is written into this register. This register is cleared by writing 1s to all bits.

5.10.2.41 SU Arbiter Control - SUACR

This register provides master arbiter control.

Table 79. SU Arbiter Control Register SUACR

Bit	Default	Description
31:30	00b	Master arbiter control, MSI Request. Used only for Fixed Priority (bit 25 set to 1). 00 = Highest priority 01 = Medium priority 10 = Lowest priority 00 = Reserved
29:28	00b	Master arbiter control, Target Split Completion. Used only for Fixed Priority (bit 25 set to 1). 00 = Highest priority 01 = Medium priority 10 = Lowest priority 00 = Reserved
27:26	00b	Target Split Completion, New Request, Deferred Read, Deferred Write. Used only for Fixed Priority (bit 25 set to 1). 00 = Highest priority 01 = Medium priority 10 = Lowest priority 00 = Reserved
25	0	Fixed/Round Robin priority selector. 1 = Fixed 0 = Round Robin
24:18	0000000b	Reserved
17	0	Master retry aborted. Write one to clear.
16	0	Master TRDY time out aborted. Write one to clear.
15:8	0	Master retry value: 0 = infinite 1 to FFh.
7:0	00h	Master TRDY time out value: 0 = disabled 1 to FFh.

5.10.2.42 SU PCI-X Capability Identifier Register - SUPCI-X_Cap_ID

The Capability Identifier Register bits adhere to the definitions in the *PCI Local Bus Specification*, Revision 2.2. This register in the PCI Extended Capability header identifies the type of Extended Capability contained in that header. In the case of the GD31244 controller, this is the PCI-X extended capability with an ID of 07H as defined by the *PCI-X Addendum to the PCI Local Bus Specification*, Revision 1.0a.

Table 80. SU PCI-X_Capability Identifier Register - SUPCI-X_Cap_ID

Bit	Default	Description
07:00	07H	Cap_Id - This field with its' 07H value identifies this item in the linked list of Extended Capability Headers as being the PCI-X capability registers.

5.10.2.43 SU PCI-X Next Item Pointer Register - SUPCI-X_Next_Item_Ptr

The Next Item Pointer Register bits adhere to the definitions in the *PCI Local Bus Specification*, Revision 2.2. This register describes the location of the next item in the function capability list. For the GD31244 controller, the next capability (PM capability list) is located at off-set E8H.

Table 81. SU PCI-X Next Item Pointer Register - SUPCI-X_Next_Item_Ptr

Bit	Default	Description
07:00	E8H	Next_Item_Pointer - This field provides an offset into the function configuration space pointing to the next item in the function capability list which is the PM capability header residing at E8H.

5.10.2.44 SU PCI-X Command Register - SUPCIXCMD

This register controls various modes and features of SATA Unit when operating in the PCI-X mode.

Table 82. SU PCI-X Command Register - SUPCIXCMD

Bit	Default	Description																
15:7	00000000 ₂	Reserved.																
6:4	011 ₂	<p>Maximum Outstanding Split Transactions - This register sets the maximum number of Split Transactions the device is permitted to have outstanding at one time.</p> <p>Register Maximum Outstanding</p> <table border="1"> <tr><td>0</td><td>1</td></tr> <tr><td>1</td><td>2</td></tr> <tr><td>2</td><td>3</td></tr> <tr><td>3</td><td>4</td></tr> <tr><td>4</td><td>8</td></tr> <tr><td>5</td><td>12</td></tr> <tr><td>6</td><td>16</td></tr> <tr><td>7</td><td>32</td></tr> </table>	0	1	1	2	2	3	3	4	4	8	5	12	6	16	7	32
0	1																	
1	2																	
2	3																	
3	4																	
4	8																	
5	12																	
6	16																	
7	32																	
3:2	00 ₂	<p>Maximum Memory Read Byte Count - This register sets the maximum byte count the device uses when initiating a Sequence with one of the burst memory read commands.</p> <p>Register Maximum Byte Count</p> <table border="1"> <tr><td>0</td><td>512</td></tr> <tr><td>1</td><td>1024</td></tr> <tr><td>2</td><td>2048</td></tr> <tr><td>3</td><td>4096</td></tr> </table>	0	512	1	1024	2	2048	3	4096								
0	512																	
1	1024																	
2	2048																	
3	4096																	
1	1 ₂	<p>Enable Relaxed Ordering - When this bit is set the GD31244 controller will set the relaxed ordering bit in the Requester Attributes of Transactions it initiates. Note that this bit does not have any effect on MSI transactions, as an MSI transaction is not permitted to set the relaxed ordering bit in its attributes.</p>																
0	0 ₂	<p>Data Parity Error Recovery Enable - The device driver sets this bit to enable the device to attempt to recover from data parity errors. When this bit is 0 and the device is in PCI-X mode, the device asserts P_SERR# (when enabled) whenever the Master Data Parity Error bit (Status register, bit 8) is set.</p> <p>NOTE: This bit has no effect when the GD31244 controller encounters a data parity error when mastering an MSI transaction.</p>																

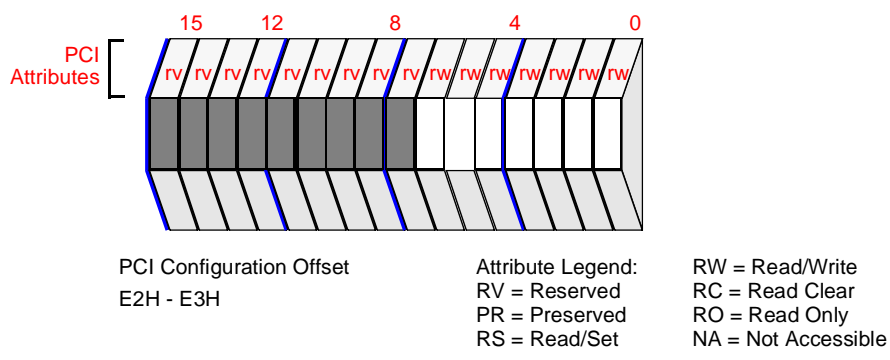

5.10.2.45 SU PCI-X Status Register - SUPCIXSR

This register identifies the capabilities and current operating mode of SATA Unit when operating in the PCI-X mode.

Table 83. SU PCI-X Status Register - SUPCIXSR (Sheet 1 of 2)

Bit	Default	Description
31:30	00 ₂	Reserved
29	0 ₂	Received Split Completion Error Message - This bit is set when the device receives a Split Completion Message with the Split Completion Error attribute bit set. Once set, this bit remains set until software writes a 1 to this location. 0 = No Split Completion error message received. 1 = A Split Completion error message has been received.
28:26	001 ₂	Designed Maximum Cumulative Read Size (DMCRS) - The value of this register depends on the setting of the Maximum Memory Read Byte Count field of the PCIXCMD register: DMCRS Max ADQs Maximum Memory Read Byte Count Register Setting 1 16 512 (Default) 2 32 1024 2 32 2048 2 32 4096
25:23	011 ₂	Designed Maximum Outstanding Split Transactions - The GD31244 controller may have up to four outstanding split transactions.
22:21	00 ₂	Designed Maximum Memory Read Byte Count - The GD31244 controller may generate memory reads with byte counts up to 512 bytes.
20	0 ₂	Device Complexity - GD31244 controller is a simple device. 0 = Simple 1 = Complex
19	0 ₂	Unexpected Split Completion - This bit is set when an unexpected Split Completion with this device Requester ID is received. Once set, this bit remains set until software writes a 1 to this location. 0 = No unexpected Split Completion has been received. 1 = An unexpected Split Completion has been received.
18	0 ₂	Split Completion Discarded - This bit is set when the device discards a Split Completion because the requester does not accept it. See Section 5.4.4 of the <i>PCI-X Addendum to the PCI Local Bus Specification</i> , Revision 1.0a for details. Once set, this bit remains set until software writes a 1 to this location. 0 = No Split Completion has been discarded. 1 = A Split Completion has been discarded. NOTE: The GD31244 controller will not set this bit since there is no Inbound address responding to Inbound Read Requests with Split Responses (Memory or Register) that has "read side effects."
17	1 ₂	GD31244 controller is a 133 MHz capable device.

Table 83. SU PCI-X Status Register - SUPCIXSR (Sheet 2 of 2)

Bit	Default	Description
16	32BITPCI#	The GD31244 controller may be configured to identify the add-in card to the system as 64-bit or 32-bit wide through a user-configurable strap (32BITPCI#). This strap will by default identify the GD31244 controller subsystem as 64-bit unless the user attaches the appropriate pull-down resistor to the strap. 0 = The bus is 32 bits wide. 1 = The bus is 64 bits wide.
15:8	FFH	Bus Number - This register is read for diagnostic purposes only. It indicates the number of the bus segment for the device containing this function. The function uses this number as part of its Requester ID and Completer ID. For all devices other than the source bridge, each time the function is addressed by a Configuration Write transaction, the function must update this register with the contents of AD[7:0] of the attribute phase of the Configuration Write, regardless of which register in the function is addressed by the transaction. The function is addressed by a Configuration Write transaction when all of the following are true: 1. The transaction uses a Configuration Write command. 2. IDSEL is asserted during the address phase. 3. AD[1:0] are 00b (Type 0 configuration transaction). 4. AD[10:08] of the configuration address contain the appropriate function number.
7:3	1FH	Device Number - This register is read for diagnostic purposes only. It indicates the number of the device containing this function, i.e., the number in the Device Number field (AD[15:11]) of the address of a Type 0 configuration transaction that is assigned to the device containing this function by the connection of the system hardware. The system must assign a device number other than 00h (00h is reserved for the source bridge). The function uses this number as part of its Requester ID and Completer ID. Each time the function is addressed by a Configuration Write transaction, the device must update this register with the contents of AD[15:11] of the address phase of the Configuration Write, regardless of which register in the function is addressed by the transaction. The function is addressed by a Configuration Write transaction when all of the following are true: 1. The transaction uses a Configuration Write command. 2. IDSEL is asserted during the address phase. 3. AD[1:0] are 00b (Type 0 configuration transaction). 4. AD[10:08] of the configuration address contain the appropriate function number.
2:0	000 ₂	Function Number - This register is read for diagnostic purposes only. It indicates the number of this function; i.e., the number in the Function Number field (AD[10:08]) of the address of a Type 0 configuration transaction to which this function responds. The function uses this number as part of its Requester ID and Completer ID.

5.10.2.46 SU PM Capability Identifier Register - SUPM_Cap_ID

The Capability Identifier Register bits adhere to the definitions in the *PCI Local Bus Specification*, Revision 2.2. This register in the PCI Extended Capability header identifies the type of Extended Capability contained in that header. In the case of the GD31244 controller, this is the PCI Bus Power Management extended capability with an ID of 01H as defined by the *PCI Bus Power Management Interface Specification*, Revision 1.1.

Table 84. SU PM_Capability Identifier Register - SUPM_Cap_ID

Bit	Default	Description
07:00	01H	Cap_Id - This field with its' 01H value identifies this item in the linked list of Extended Capability Headers as being the PCI Power Management Registers.

5.10.2.47 SU PM Next Item Pointer Register - SUPM_Next_Item_Ptr

The Next Item Pointer Register bits adhere to the definitions in the *PCI Local Bus Specification*, Revision 2.2. This register describes the location of the next item in the function capability list. For the GD31244 controller, the next capability (MSI capability list) is located at offset F0H.

Table 85. SU PM Next Item Pointer Register - SUPM_Next_Item_Ptr

PCI Configuration Offset E9H		
Attribute Legend: RV = Reserved PR = Preserved RS = Read/Set RW = Read/Write RC = Read Clear RO = Read Only NA = Not Accessible		
Bit	Default	Description
07:00	F0H	Next_Item_Pointer - This field provides an offset into the function configuration space pointing to the next item in the function capability list which in the GD31244 controller is the MSI capability header residing at F0H.

5.10.2.48 SU Power Management Capabilities Register - SUPMCR

Power Management Capabilities bits adhere to the definitions in the *PCI Bus Power Management Interface Specification*, Revision 1.1. This register is a 16-bit read-only register which provides information on the capabilities of the SATA Unit function related to power management.

Table 86. SU Power Management Capabilities Register - SUPMCR

Bit	Default	Description
15:11	00000 ₂	PME_Support - This function is not capable of asserting the PME# signal in any state, since PME# is not supported by the GD31244 controller.
10	0 ₂	D2_Support - This bit is set to 0 ₂ indicating that the GD31244 controller does not support the D2 Power Management State
9	0 ₂	D1_Support - This bit is set to 0 ₂ indicating that the GD31244 controller does not support the D1 Power Management State
8:6	000 ₂	Aux_Current - This field is set to 000 ₂ indicating that the GD31244 controller has no current requirements for the 3.3Vaux signal as defined in the <i>PCI Bus Power Management Interface Specification</i> , Revision 1.1
5	1 ₂	DSI - This field is set to 1 ₂ meaning that this function will require a device specific initialization sequence following the transition to the D0 uninitialized state.
4	0 ₂	Reserved.
3	0 ₂	PME Clock - Since the GD31244 controller does not support PME# signal generation.
2:0	010 ₂	Version - Setting these bits to 010 ₂ means that this function complies with <i>PCI Bus Power Management Interface Specification</i> , Revision 1.1

PCI Attributes

PCI Configuration Offset
EAH - EBH

Attribute Legend:
RV = Reserved
PR = Preserved
RS = Read/Set

RW = Read/Write
RC = Read Clear
RO = Read Only
NA = Not Accessible

5.10.2.49 SU Power Management Control/Status Register - SUPMCSR

Power Management Control/Status bits adhere to the definitions in the *PCI Bus Power Management Interface Specification*, Revision 1.1. This 16-bit register is the control and status interface for the power management extended capability.

Table 87. SU Power Management Control/Status Register - SUPMCSR

Bit	Default	Description
15	0 ₂	PME_Status - This function is not capable of asserting the PME# signal in any state, since PME## is not supported by the GD31244 controller.
14:9	00H	Reserved
8	0 ₂	PME_En - This bit is hardwired to read-only 0 ₂ since this function does not support PME# generation from any power state.
7:2	000000 ₂	Reserved
1:0	00 ₂	Power State - This 2-bit field is used both to determine the current power state of a function and to set the function into a new power state. The definition of the values is: 00 ₂ - D0 01 ₂ - D1 (Unsupported) 10 ₂ - D2 (Unsupported) 11 ₂ - D3 _{hot} The GD31244 controller supports only the D0 and D3 _{hot} states.

Note:

- D0 – GD31244 supports D0 state and (as in all PCI compliant devices) will be in the D0 state before use. After power on reset or transitioning from D3_{hot} GD31244 is in D0 in an uninitialized state. Once initialized it is in a D0 active date.
- D3 – GD31244 supports D3 state. The D3 state has two variants D3_{hot} and D3_{cold}. D3_{hot} the device has VCC applied to it and D3_{cold}.the device has VCC removed from it. Removing power will place the device in D3_{cold} state. From a D3_{cold} state the device can transition to a D0 uninitialized state by reapplying Vcc and asserting a PCI RST#. D3_{hot} can be transitioned to an uninitialized D0 state through the software writing to the PMSCR register or having PCI RST# asserted. D3_{hot} respond to configuration space accesses as long as their power and clock are supplied. The D3_{hot} device can go into a D0 uninitialized state by performing a soft reset (without PCI RST# being asserted).
- Refer to the PCI Bus Power Management Interface Specification for more information on the power management states.

5.10.2.50 SU MSI Capability Identifier Register - SUMSI_Cap_ID

The MSI Capability Identifier Register bits adhere to the definitions in the *PCI Local Bus Specification*, Revision 2.2. This register in the PCI Extended Capability header identifies the type of Extended Capability contained in that header. The value of 05H in this field identifies the function as message signaled interrupt capable.

Table 88. SU MSI Capability Identifier Register - SUMSI_Cap_ID

Bit	Default	Description
07:00	05H	MSI_Cap_Id - This field with its 05H value identifies this item in the linked list of Extended Capability Headers as being the message signaled interrupt capability item.

5.10.2.51 SU MSI Next Item Pointer Register - SUMSI_Next_Ptr

The Next Item Pointer Register bits adhere to the definitions in the *PCI Local Bus Specification*, Revision 2.2. This register describes the location of the next item in the function capability list. For the GD31244 controller, this the final capability list, and hence, this register is set to 00H.

Table 89. SU MSI Next Item Pointer Register - SUMSI_Next_Ptr

PCI Configuration Offset F1H		Attribute Legend: RV = Reserved PR = Preserved RS = Read/Set RW = Read/Write RC = Read Clear RO = Read Only NA = Not Accessible
Bit	Default	Description
07:00	00H	MSI_Next_Pointer - This field provides an offset into the function configuration space pointing to the next item in the function capability list. Since the MSI capabilities are the last in the linked list of extended capabilities in the GD31244 controller, the register is set to 00H.

5.10.2.52 SU MSI Message Control Register - SUMSI_Message_Control

The Message Control Register provides system software control over MSI. After reset, MSI is disabled. System software is permitted to modify the Message Control register read/write bits and fields while a device driver is not permitted to modify them.

Table 90. SU MSI Message Control Register - SUMSI_Message_Control

Bit	Default	Description
15:8	00H	Reserved
7	1 ₂	64-bit Address Support - This field is set to 1 ₂ indicating that the GD31244 controller is capable of generating a 64-bit message address.
6:4	000 ₂	Multiple Message Enable - System software writes to this field to indicate the number of messages allocated to the GD31244 controller. While, the GD31244 controller requests two messages, it is possible that system software will only allocate one message. The device hardware is designed to handle both cases. Note: The maximum value assigned to this field should be 2 or less.
3:1	010 ₂	Multiple Message Capable - This field is set to 010 ₂ indicating that the GD31244 controller may issue up to four unique interrupt messages. Note: The Host can only program the Multiple Message Enable field with (0, 1, or 2). 000 ₂ = 1 001 ₂ = 2 010 ₂ = 4 011 ₂ = 8 100 ₂ = 16 101 ₂ = 32 110 ₂ = Reserved 111 ₂ = Reserved
0	0 ₂	MSI Enable - Setting this bit enables the GD31244 controller MSI functionality and disables the use of the P_INTA# interrupt output for GD31244 controller interrupts.

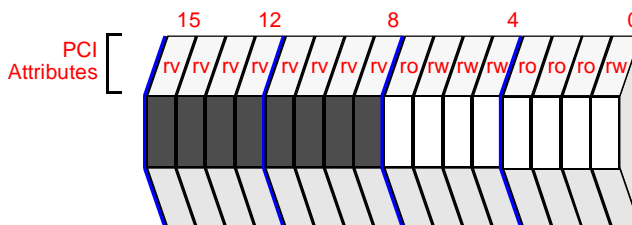

PCI Configuration Offset
F2H - F3H

Attribute Legend:
RV = Reserved
PR = Preserved
RS = Read/Set

RW = Read/Write
RC = Read Clear
RO = Read Only
NA = Not Accessible

5.10.2.53 SU MSI Message Address Register - SUMSI_Message_Address

The Message address register specifies the DWORD aligned address for the MSI memory write transaction. The value is set by system software during initialization.

Table 91. SU MSI Message Address Register - SUMSI_Message_Address

Bit	Default	Description
31:2	00000000H	Message Address - DWORD aligned Message Address. This value is set by system software.
1:0	00 ₂	Reserved.

5.10.2.54 SU MSI Message Upper Address Register - SUMSI_Message_Upper_Address

The Message Upper Address register is set during system initialization when system software wishes to place the MSI address location above the 4 G address boundary. When this register is set to a non-zero value, the GD31244 controller will generate a dual address cycle for the MSI write command and will use the contents of this register as the upper 32-bits of that address.

Table 92. SU MSI Message Upper Address Register - SUMSI_Message_Upper_Address

Bit	Default	Description
31:00	00000000H	Message Address - Upper Message Address. This value is set by system software.

PCI Configuration Offset
F8H - FBH

Attribute Legend:
 RW = Read/Write
 RV = Reserved
 PR = Preserved
 RS = Read/Set
 RC = Read Clear
 RO = Read Only
 NA = Not Accessible

5.10.2.55 SU MSI Message Data Register- SUMSI_Message_Data

The value in the Message Data Register contains the data used during an MSI write transaction. The GD31244 controller interrupts may be represented by four, two or a single message. Interrupt handler software will need to read the GD31244 controller interrupt status registers to determine the cause of the interrupt when more than one source is represented by less than four messages.

During an MSI write data phase, the value in the Message Data Register will be driven on to AD[15:0] while AD[31:16] will be driven to zero. C/BE[3:0]# are asserted during the data phase of the memory write transaction.

Table 93. SU MSI Message Data Register - SUMSI_Message_Data

Bit	Default	Description
15:00	0000H	Message Data - System software specifies a 16-bit value to be transferred during the data phase of an MSI write transaction.

5.10.3 SU PCI IDE Mode Command Block Registers

This section defines the Command Block Registers when in PCI IDE mode.

5.10.3.1 SU IDE Data Port Register - SUIDR

The SU IDE Data Port Register is a 16-bit read/write register and is used to transfer data during Programmed I/O (PIO) mode reads/writes. On the GD31244 controller, the Data Port register may also be read or written as a 32-bit Data Port. The GD31244 controller internally breaks the 32-bit transaction into two back-to-back 16-bit transactions. It is recommended that the Data Port register is always accessed in either 16-bit or 32-bit quantity for a given PIO sequence. Refer to the *AT Attachment with Packet Interface-6 (ATA/ATAPI-6) Specification*.

Table 94. SU IDE Data Port Register - SUIDR

Bit	Default	Description
15:00	0000H	Data Port - This register is used to transfer data during PIO reads and writes. This register shall be accessed only when the DRQ bit in the status register, SU IDE Status Register - SUIISR , is set.

5.10.3.2 SU IDE Error Register - SUIER

The SU IDE Error Register is an 8-bit read-only register. When the SU IDE Error Register is written to, instead the SU IDE Features Register is written. The SU IDE Error Register contains error status for the current command. The content of this register shall be valid when the ERR bit is set in the [SU IDE Status Register - SUI SR](#). The SU IDE Error Register is command dependent and the bits are defined in the *ATA Attachment with Packet Interface-6 (ATA/ATAPI-6) Specification*.

Table 95. SU IDE Error Register - SUIER

Bit	Default	Description
07:00	Device Dependent ^a	The bits in this register are command dependent. The bits are only valid when the ERR bit (bit 0) in the SU IDE Status Register - SUI SR is set. Refer to the <i>ATA Attachment with Packet Interface-6 (ATA/ATAPI-6) Specification</i> .

a. After a hardware reset, software reset, or an EXECUTE DEVICE DIAGNOSTIC command, the device will return a diagnostic code. The diagnostic code is device dependent. *ATA Attachment with Packet Interface-6 (ATA/ATAPI-6) Specification*.

5.10.3.3 SU IDE Features Register - SUIFR

The SU IDE Features Register is a write-only register. When this address is read, instead the SU IDE Error Register is read. The content of the SU IDE Features Register is a command parameter. the content of this register must be loaded before the SU IDE Command Register is written. The content of the SU IDE Features Register is command dependent. Refer to the *AT Attachment with Packet Interface-6 (ATA/ATAPI-6) Specification*.

Table 96. SU IDE Features Register - SUIFR

PCI IDE Mode BAR0/BAR2 Offset = 01H		
Attribute Legend: RW = Read/Write RV = Reserved RC = Read Clear PR = Preserved RO = Read Only RS = Read/Set NA = Not Accessible WO = Write Only		
Bit	Default	Description
07:00	00H	Features - This register is command dependent. For example, it may be a parameter as an extension to the SU IDE Command Register. In the <i>AT Attachment with Packet Interface-6 (ATA/ATAPI-6) Specification</i> , this register acts as a 2-byte FIFO in order to implement a 16-bit Feature register.

5.10.3.4 SU IDE Sector Count Register - SUISCR

The SU IDE Sector Count Register is a read/write register. The content of the SU IDE Sector Count Register is a command parameter. The content of this register must be loaded before the SU IDE Command Register is written. The content of the SU IDE Sector Count Register is command dependent. Refer to the *AT Attachment with Packet Interface-6 (ATA/ATAPI-6) Specification*.

Table 97. SU IDE Sector Count Register - SUISCR

PCI IDE Mode BAR0/BAR2 Offset = 02H		
Attribute Legend: RW = Read/Write RV = Reserved RC = Read Clear PR = Preserved RO = Read Only RS = Read/Set NA = Not Accessible		
Bit	Default	Description
07:00	Device Dependent ^a	Sector Count - <ul style="list-style-type: none"> This 8-bit field indicates the number of sectors to transfer for a given command. In the <i>AT Attachment with Packet Interface-6 (ATA/ATAPI-6) Specification</i>, this register acts as a 2-byte FIFO in order to implement a 16-bit sector number.

a. After a hardware reset, software reset, or an EXECUTE DEVICE DIAGNOSTIC command, the device will return a diagnostic code. The diagnostic code is device dependent. Refer to the *AT Attachment with Packet Interface-6 (ATA/ATAPI-6) Specification*.

5.10.3.5 SU IDE Sector Number Register - SUISNR

The SU IDE Sector Number Register is a read/write register. The content of the SU IDE Sector Number Register is a command parameter. The content of this register must be loaded before the SU IDE Command Register is written. The content of this register is command dependent. Refer to the *AT Attachment with Packet Interface-6 (ATA/ATAPI-6) Specification*.

Table 98. SU IDE Sector Number Register - SUISNR

<p>Attribute Legend: RW = Read/Write RV = Reserved RC = Read Clear PR = Preserved RO = Read Only RS = Read/Set NA = Not Accessible</p>		
Bit	Default	Description
07:00	Device Dependent ^a	Sector Number - This field is dependent on the device access methods. There are three method: <ul style="list-style-type: none"> • CHS Mode: This field indicates the sector number. • 28-bit LBA Mode: This field is used for bit positions LBA[7:0] of the 28-bit addressing LBA[27:0]. • 48-bit LBA Mode: This field is used for bit positions LBA[7:0] and LBA[31:24] of the 48-bit addressing LBA[47:0]. This register acts as a 2-byte FIFO. The higher byte is written first followed by the lower byte.

a. After a hardware reset, software reset, or an EXECUTE DEVICE DIAGNOSTIC command, the device will return a diagnostic code. The diagnostic code is device dependent. Refer to the *AT Attachment with Packet Interface-6 (ATA/ATAPI-6) Specification*.

5.10.3.6 SU IDE Cylinder Low Register - SUICLR

The SU IDE Cylinder Low Register is a read/write register. The content of the SU IDE Cylinder Low Register is a command parameter. The content of this register must be loaded before the SU IDE Command Register is written. The content of the SU IDE Cylinder Low Register is command dependent. Refer to the *AT Attachment with Packet Interface-6 (ATA/ATAPI-6) Specification*.

Table 99. SU IDE Cylinder Low Register - SUICLR

PCI IDE Mode BAR0/BAR2 Offset = 04H									
Attribute Legend: <table style="display: inline-table; vertical-align: top; margin-left: 20px;"> <tr> <td>RW = Read/Write</td> </tr> <tr> <td>RV = Reserved</td> </tr> <tr> <td>PR = Preserved</td> </tr> <tr> <td>RS = Read/Set</td> </tr> <tr> <td>RC = Read Clear</td> </tr> <tr> <td>RO = Read Only</td> </tr> <tr> <td>NA = Not Accessible</td> </tr> </table>			RW = Read/Write	RV = Reserved	PR = Preserved	RS = Read/Set	RC = Read Clear	RO = Read Only	NA = Not Accessible
RW = Read/Write									
RV = Reserved									
PR = Preserved									
RS = Read/Set									
RC = Read Clear									
RO = Read Only									
NA = Not Accessible									
Bit	Default	Description							
07:00	Device Dependent ^a	Cylinder Low - This field is dependent on the device access methods. There are three methods: <ul style="list-style-type: none"> • CHS Mode: In CHS mode, this field indicates the lower 8 bits of the 16-bit cylinder number identifier. • 28-bit LBA Mode: This field is used for bit positions LBA[15:8] of the 28-bit addressing LBA[27:0]. • 48-bit LBA Mode: This field is used for bit positions LBA[15:8] and LBA[39:32] of the 48-bit addressing LBA[47:0]. This register acts as a 2-byte FIFO. The higher byte is written first followed by the lower byte. 							

a. After a hardware reset, software reset, or an EXECUTE DEVICE DIAGNOSTIC command, the device will return a diagnostic code. The diagnostic code is device dependent. Refer to the *AT Attachment with Packet Interface-6 (ATA/ATAPI-6) Specification*.

5.10.3.7 SU IDE Cylinder High Register - SUICHR

The SU IDE Cylinder High Register is a read/write register. The content of the SU IDE Cylinder High Register is a command parameter. The content of this register must be loaded before the SU IDE Command Register is written. The content of the SU IDE Cylinder High Register is command dependent. Refer to the *AT Attachment with Packet Interface-6 (ATA/ATAPI-6) Specification*.

Table 100. SU IDE Cylinder High Register - SUICHR

PCI IDE Mode BAR0/BAR2 Offset = 05H		
Attribute Legend: RW = Read/Write RV = Reserved RC = Read Clear PR = Preserved RO = Read Only RS = Read/Set NA = Not Accessible		
Bit	Default	Description
07:00	Device Dependent ^a	Cylinder High - This field is dependent on the device access methods. There are three methods: <ul style="list-style-type: none"> • CHS Mode: In CHS mode, this field indicates the higher 8 bits of the 16-bit cylinder number identifier. • 28-bit LBA Mode: This field is used for bit positions LBA[23:16] of the 28-bit addressing LBA[27:0]. • 48-bit LBA Mode: This field is used for bit positions LBA[23:16] and LBA[47:40] of the 48-bit addressing LBA[47:0]. This register acts as a 2-byte FIFO. The higher byte is written first followed by the lower byte.

a. After a hardware reset, software reset, or an EXECUTE DEVICE DIAGNOSTIC command, the device will return a diagnostic code. The diagnostic code is device dependent. Refer to the *AT Attachment with Packet Interface-6 (ATA/ATAPI-6) Specification*.

5.10.3.8 SU IDE Device/Head Register - SUIDR

This SU IDE Device/Head Register is a read/write register. The content of the SU IDE Device/Head Register is a command parameter. The content of this register must be loaded before the SU IDE Command Register is written. The content of the SU IDE Device/Head Register is command dependent. Refer to the *AT Attachment with Packet Interface-6 (ATA/ATAPI-6) Specification*.

Table 101. SU IDE Device/Head Register - SUIDHR

PCI IDE Mode BAR0/BAR2 Offset = 06H		
Attribute Legend: RW = Read/Write RV = Reserved RC = Read Clear PR = Preserved RO = Read Only RS = Read/Set NA = Not Accessible		
Bit	Default	Description
07	Device Dependent ^a	Reserved
06		Logical Addressing Mode - This bit indicates the addressing mode: 0 = CHS (Cylinder/Head/Sector) Mode 1 = LBA (Logical Block Addressing) Mode
05		Reserved
04		Device Select (DEV Bit) - This bit is used to select one of the two devices: 0 = Device 0 1 = Device 1
03-00		Head - This field is dependent on the device access methods. There are three methods: <ul style="list-style-type: none"> • CHS Mode: In CHS mode, this field indicates the head number. • 28-bit LBA Mode: This field is used for bit positions LBA[27:24] of the 28-bit addressing LBA[27:0]. • 48-bit LBA Mode: This field is reserved.

a. After a hardware reset, software reset, or an EXECUTE DEVICE DIAGNOSTIC command, the device will return a diagnostic code. The diagnostic code is device dependent. Refer to the *AT Attachment with Packet Interface-6 (ATA/ATAPI-6) Specification*.

5.10.3.9 SU IDE Status Register - SUI SR

The SU PCI DPA Status Register is an 8-bit read-only register. When the SU IDE Status Register is written, the SU IDE Command Register is written instead. This register provides the status of the device and the interface. Reading this register implicitly clears any pending interrupt. Instead, the Alternate Status register may be used to read the status of a device without causing any pending interrupt to get cleared. Some of the bits in this register are command-dependent and are described in the *AT Attachment with Packet Interface-6 (ATA/ATAPI-6) Specification*. Information in this register is updated by the device sending a Device-to-Host Register FIS or PIO Setup FIS.

Table 102. SU IDE Status Register - SUI SR

Bit	Default	Description
07	Device Dependent [†]	BSY - When this bit is set the interface/device is busy. For example, the device may be working a previous command. This bit is set immediately after the Command register is written and a Host-to-Device Register FIS is sent to the device, indicating that the interface is busy. The device is then responsible to clear this bit by sending a PIO Setup FIS or Device-to-Host Register FIS.
06		Device Ready (DRDY Bit) - This bit when set indicates that the device is ready.
05		This bit is command dependent. Refer to the <i>AT Attachment with Packet Interface-6 (ATA/ATAPI-6) Specification</i> .
04		This bit is command dependent. Refer to the <i>AT Attachment with Packet Interface-6 (ATA/ATAPI-6) Specification</i> .
03		Data Request (DRQ Bit) - This bit is set when the device is ready to transfer data.
02		This bit is command dependent. Refer to the <i>AT Attachment with Packet Interface-6 (ATA/ATAPI-6) Specification</i> .
01		This bit is command dependent. Refer to the <i>AT Attachment with Packet Interface-6 (ATA/ATAPI-6) Specification</i> .
00		Device Error (ERR Bit) - This bit when set indicates that an error occurred. The SU IDE Error Register - SUI ER provides further error information.

[†] After power-on, a value of 7FH is returned in this register when read before a device is detected on the serial link. This is consistent with the ATA standard, indicating that a device is not connected to the cable. After the device is detected and a communication link is established between the host and the device, a value of 80H will be read. Bit 7 (BSY bit) set indicates that the device has been detected, but is busy executing its initialization and diagnostics. After the device is done with its initialization and diagnostics sequence, it will send a Device-to-Host Register FIS with bit 7 (BSY bit) cleared.

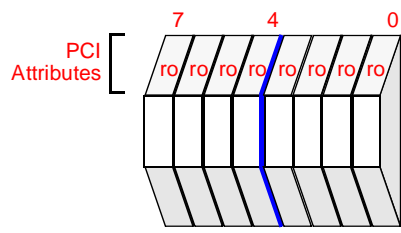

PCI IDE Mode BAR0/BAR2 Offset
= 07H

Attribute Legend:
 RV = Reserved
 PR = Preserved
 RS = Read/Set
 RW = Read/Write
 RC = Read Clear
 RO = Read Only
 NA = Not Accessible

5.10.3.10 SU IDE Command Register - SUICR

The SU IDE Command Register is a write-only register. When the SU IDE Command register is read, instead the SU IDE Status register will be read. A command is initiated by writing this register. Refer to the *AT Attachment with Packet Interface-6 (ATA/ATAPI-6) Specification*.

Table 103. SU IDE Command Register - SUICR

PCI IDE Mode BAR0/BAR2 Offset = 07H		
Attribute Legend: RV = Reserved RW = Read/Write PR = Preserved RC = Read Clear RS = Read/Set RO = Read Only WO = Write Only NA = Not Accessible		
Bit	Default	Description
07:00	00H	Command - This register is used to initiate a command. This register must be written last. For example, it must be written after the other Command Block registers are written. Because the rest of the registers are parameters for the command.

5.10.4 SU PCI IDE Mode Control Block Registers

This section defines the Device Control and Alternate Status Registers.

5.10.4.1 SU IDE Device Control Register - SUIDCR

The SU IDE Device Control Register is a write-only register. When the SU IDE Device Control Register is read, instead the SU IDE Alternate Status Register is read. The SU IDE Device Control Register is used to initiate a software reset to the device. It is also used to enable/disable interrupt. Refer to the *ATA Attachment with Packet Interface-6 (ATA/ATAPI-6) Specification*.

Table 104. SU IDE Device Control Register - SUIDCR

Bit	Default	Description
07	0 ₂	High Order Byte (HOB Bit) - When operating in 48-bit LBA addressing mode, the Sector Count, Cylinder Low, and Cylinder High registers act a 2-byte deep FIFOs. For example, each of these registers are 16-bit registers with access to only one byte at a time. The HOB bit provides a mechanism for software to be able to read either byte. Setting this bit to one allows reading the upper byte, while setting the HOB bit to zero allows reading the lower byte
06	0 ₂	Reserved.
05	0 ₂	Reserved.
04	0 ₂	Reserved.
03	0 ₂	Reserved.
02	0 ₂	SRST - This bit is used by the processor to do a software reset.
01	0 ₂	nIEN - Interrupt Enable, this bit when cleared enables the assertion of interrupt signal to the processor. When set, interrupt to the processor is masked.
00	0 ₂	Reserved. This bit shall always be cleared.

PCI Attributes [

PCI IDE Mode BAR1/BAR3 Offset
= 02H

Attribute Legend:
RW = Read/Write
RV = Reserved
RC = Read Clear
PR = Preserved
RO = Read Only
RS = Read/Set
NA = Not Accessible
WO = Write Only

5.10.4.2 SU IDE Alternate Status Register - SUIASR

The SU IDE Alternate Status Register is an 8-bit read-only register. When the SU IDE Alternate Status Register is written to, instead the SU IDE Device Control Register is written. This register contains the same information as the SU IDE Status Register, [Table 102, “SU IDE Status Register - SUIISR” on page 174](#). The difference is that when this register is read, any pending interrupt is not cleared. Refer to the *AT Attachment with Packet Interface-6 (ATA/ATAPI-6) Specification*.

Table 105. SU IDE Alternate Status Register - SUIASR

PCI IDE Mode BAR1/BAR3 Offset = 02H		
Attribute Legend:		
RW = Read/Write RV = Reserved PR = Preserved RS = Read/Set RC = Read Clear RO = Read Only NA = Not Accessible		
Bit	Default	Description
07:00	Refer to Section 102, “SU IDE Status Register - SUIISR” on page 174 .	Alternate Status Register - This register contains the same information as in the SU IDE Status Register. The difference is that when this register is read, any pending interrupts are not cleared. Refer to Section 102, “SU IDE Status Register - SUIISR” on page 174 .

5.10.5 SU PCI IDE Mode DMA Registers

This section defines the DMA Registers.

5.10.5.1 SU IDE Channel 0 DMA Command Register - SUICDCR0

The SU IDE Channel 0 DMA Command Register enables/disables the DMA engine (bus master capability) and also provides direction control for DMA transfers.

Table 106. SU IDE Channel 0 DMA Command Register - SUICDCR0

Bit	Default	Description
15:10	00H	Reserved
09	0 ₂	First Party DMA Direction: 0 = From Device to Host 1 = From Host to Device
08	0 ₂	First Party DMA Active: 0 = Not Active 1 = Active
07:04	0H	Reserved
03	0 ₂	DMA Read/Write Control: 0 = Reads Memory to write FIFO. FIFO data is written to SATA device. 1 = Writes Memory with FIFO data. FIFO contains data read from SATA device. This bit must NOT be changed when the DMA is active. While synchronous DMA transfer is in progress, this bit will be READ ONLY. The bit will return to read/write once the synchronous DMA transfer has been completed or halted.
02:01	00 ₂	Reserved.
00	0 ₂	Start/Stop DMA Transfer: 1 = Start; 0 = Stop. When this bit is set to 1, the DMA operation starts. The controller transfers data between the device and memory only while this bit is set. Operation may be stopped by writing a 0 to this bit. This results in all state information being lost (i.e., operation cannot be stop and then resumed). When this bit is set to 0 while bus master operation is still active (i.e., bit 0 = 1 in the DMA Status Register) and data transfer has not yet finished (i.e., bit 2 = 0 in the DMA Status Register), the DMA command is aborted and data transferred from the drive may be discarded by the SATA port rather than being written to memory. This bit is intended to be set to 0 after the data transfer is completed, as indicated by either bit 0 or bit 2 set in the DMA Status Register.

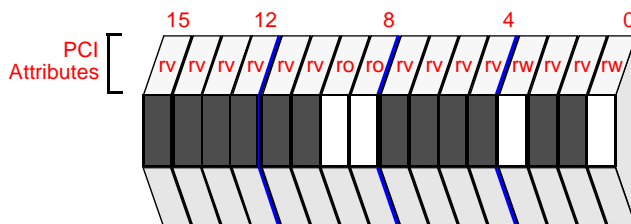

PCI IDE Mode BAR4 Offset
= 00H
PCI IDE Mode BAR4 Offset
= 00H

Attribute Legend:
RV = Reserved
RC = Read Clear
RO = Read Only
RS = Read/Set
RW = Read/Write
NA = Not Accessible

5.10.5.2 SU IDE Channel 0 DMA Status Register - SUICDSR0

The SU IDE Channel 0 DMA Status Register provides status of the DMA engine.

Table 107. SU IDE Channel 0 DMA Status Register - SUICDSR0

Bit	Default	Description
07	0 ₂	This bit is hardwired to 0. Simplex only.
06	1 ₂	Drive 1 DMA Capable: 1 = Drive 1 is capable of DMA transfers. This bit is a software controlled status bit that indicates DMA device capability and does not affect hardware operation.
05	1 ₂	Drive 0 DMA Capable: 1 = Drive 0 is capable of DMA transfers. This bit is a software controlled status bit that indicates DMA device capability and does not affect hardware operation.
04:03	00 ₂	Reserved.
02	0 ₂	Interrupt Status: This bit, when set to a 1, indicates that a device has asserted its interrupt line. When this is set to 1, all read data from the device has been transferred to memory and all write data has been transferred to the device. Software sets this bit to a 0 by writing a 1 to it.
01	0 ₂	DMA Error: This bit is set to 1 under the following conditions while transferring data on the PCI bus. <ul style="list-style-type: none"> • Detected a master abort on the PCI bus • Detected a target abort on the PCI bus • Detected a parity error on the PCI bus Software sets this bit to 0 by writing a 1 to it.
00	0 ₂	DMA Active: The GD31244 sets this bit to 1 when bit 0 in the SU IDE Channel 0 DMA Command Register is set to 1. Refer to Table 106, "SU IDE Channel 0 DMA Command Register - SUICDCR0" on page 178 . The GD31244 sets this bit to 0 when the last transfer is performed (where EOT for that descriptor is set). The GD31244 also sets this bit to 0 when bit 0 of the SU IDE Channel 0 DMA Command Register is set to 0. When this bit is read as a 0, all data transferred from the drive during the previous bus master command is visible in memory, unless the DMA command was aborted.

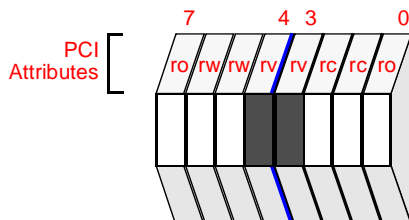

PCI IDE Mode BAR4 Offset
= 02H

Attribute Legend:
 RV = Reserved
 PR = Preserved
 RS = Read/Set
 RW = Read/Write
 RC = Read Clear
 RO = Read Only
 NA = Not Accessible

5.10.5.3 SU IDE Channel 0 DMA Descriptor Table Pointer Register - SUICDDTPR0

This SU IDE Channel 0 DMA Descriptor Table Pointer Register contains the lower 32-bit PCI address. In PCI IDE mode, the SU IDE Channel 0 DMA Descriptor Table Pointer Register points to system memory.

Table 108. SU IDE Channel 0 DMA Descriptor Table Pointer Register - SUICDDTPR0

<p>PCI IDE Mode BAR4 Offset = 04H</p> <p>Attribute Legend: RW = Read/Write RV = Reserved PR = Preserved RS = Read/Set RC = Read Clear RO = Read Only NA = Not Accessible</p>		
Bit	Default	Description
31:02	0000 0000H	PCI Address - is lower PCI address. This register contains the base address of the descriptor table. The descriptor table must be DWORD aligned and must not cross a 64 Kbyte boundary.
01:00	00 ₂	Reserved.

5.10.5.4 SU IDE Channel 1 DMA Command Register - SUICDCR1

The SU IDE Channel 1 DMA Command Register enables/disables the DMA engine (bus master capability) and also provides direction control for DMA transfers.

Table 109. SU IDE Channel 1 DMA Command Register - SUICDCR1

Bit	Default	Description
15:10	00H	Reserved
09	0 ₂	First Party DMA Direction: 0 = From Device to Host 1 = From Host to Device
08	0 ₂	First Party DMA Active: 0 = Not Active 1 = Active
07:04	0H	Reserved
03	0 ₂	DMA Read/Write Control: 0 = Reads 1 = Writes This bit must NOT be changed when the DMA is active. While synchronous DMA transfer is in progress, this bit will be READ ONLY. The bit will return to read/write once the synchronous DMA transfer has been completed or halted.
02:01	00 ₂	Reserved.
00	0 ₂	Start/Stop DMA Transfer: 0 = Stop 1 = Start When this bit is set to 1, the DMA operation starts. The controller transfers data between the device and memory only while this bit is set. Operation may be stopped by writing a 0 to this bit. This results in all state information being lost (i.e., operation cannot be stop and then resumed). When this bit is set to 0 while bus master operation is still active (i.e., bit 0 = 1 in the DMA Status Register) and data transfer has not yet finished (i.e., bit 2 = 0 in the DMA Status Register), the DMA command is aborted and data transferred from the drive may be discarded by the SATA port rather than being written to memory. This bit is intended to be set to 0 after the data transfer is completed, as indicated by either bit 0 or bit 2 set in the DMA Status Register.

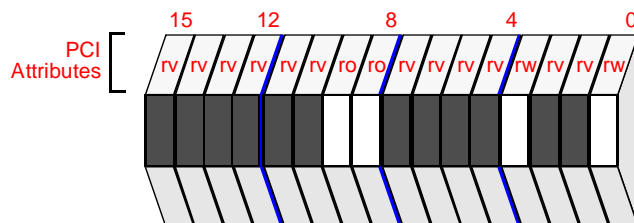

PCI IDE Mode BAR4 Offset
= 08H

Attribute Legend:
RV = Reserved
PR = Preserved
RS = Read/Set
RW = Read/Write
RC = Read Clear
RO = Read Only
NA = Not Accessible

5.10.5.5 SU IDE Channel 1 DMA Status Register - SUICDSR1

The SU IDE Channel 1 DMA Status Register provides status of the DMA engine.

Table 110. SU IDE Channel 1 DMA Status Register - SUICDSR1

Bit	Default	Description
07	0 ₂	This bit is hardwired to 0. Simplex only.
06	1 ₂	Drive 1 DMA Capable: 1 = Drive 1 is capable of DMA transfers. This bit is a software controlled status bit that indicates DMA device capability and does not affect hardware operation.
05	1 ₂	Drive 0 DMA Capable: 1 = Drive 0 is capable of DMA transfers. This bit is a software controlled status bit that indicates DMA device capability and does not affect hardware operation.
04:03	00 ₂	Reserved.
02	0 ₂	Interrupt Status: This bit, when set to a 1, indicates that a device has asserted its interrupt line. When this bit is set to 1, all read data from the device has been transferred to memory and all write data has been transferred to the device. Software sets this bit to a 0 by writing a 1 to it.
01	0 ₂	DMA Error: This bit is set to 1 under the following conditions while transferring data on the PCI bus. <ul style="list-style-type: none"> Detected a master abort on the PCI bus Detected a target abort on the PCI bus Detected a parity error on the PCI bus Software sets this bit to 0 by writing a 1 to it.
00	0 ₂	DMA Active: The GD31244 sets this bit to 1 when bit 0 in the SU IDE Channel 0 DMA Command Register is set to 1. Refer to Table 109, "SU IDE Channel 1 DMA Command Register - SUICDCR1" on page 181 . The GD31244 sets this bit to 0 when the last transfer is performed (where EOT for that descriptor is set). The GD31244 also sets this bit to 0 when bit 0 of the SU IDE Channel 1 DMA Command Register is set to 0. When this bit is read as a 0, all data transferred from the drive during the previous bus master command is visible in memory, unless the DMA command was aborted.

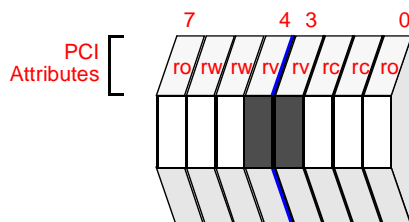

PCI IDE Mode BAR4 Offset
= 0AH

Attribute Legend:
 RV = Reserved
 PR = Preserved
 RS = Read/Set
 RW = Read/Write
 RC = Read Clear
 RO = Read Only
 NA = Not Accessible

5.10.5.6 SU IDE Channel 1 DMA Descriptor Table Pointer Register - SUICDDTPR1

This SU IDE Channel 1 DMA Descriptor Table Pointer Register contains the lower 32-bit PCI address. In PCI IDE mode, the SU IDE Channel 0 DMA Descriptor Table Pointer Register points to system memory.

Table 111. SU IDE Channel 1 DMA Descriptor Table Pointer Register - SUICDDTPR1

PCI IDE Mode BAR4 Offset = 0CH		Attribute Legend: RV = Reserved PR = Preserved RS = Read/Set RW = Read/Write RC = Read Clear RO = Read Only NA = Not Accessible
Bit	Default	Description
31:02	0000 0000H	PCI Address - is lower PCI address. This register contains the base address of the descriptor table. The descriptor table must be DWORD aligned and must not cross a 64 Kbyte boundary.
01:00	00 ₂	Reserved.

5.10.6 SU PCI DPA Mode Registers

This section defines the SATA Unit registers as viewed from the PCI bus when in Direct Port Access mode. The registers are memory-mapped into the PCI memory space.

Every PCI device/function implements its own separate configuration address space and configuration registers. The *PCI Local Bus Specification*, Revision 2.2 requires that configuration space be 256 bytes, and the first 64 bytes must adhere to a predefined header format.

Refer to [Section 5.10.1, “PCI IDE Mode Registers” on page 103](#) for the configuration space, as the configuration registers are the same as in the PCI IDE mode. There are a few registers that are different that are highlighted in this section.

When in the Direct Port Access mode, the Serial ATA Unit registers are mapped into the PCI memory space. Only one 64-bit Base Address Register is defined to access all four SATA port registers. [Table 112](#) shows the differences in the configuration space between the two modes.

The SATA Port registers are listed in [Table 113](#). When in Direct Port Access mode, [SU PCI DPA Base Address Register 0 - SUDBAR0](#) and [SU PCI DPA Upper Base Address Register 0 - SUPDUBAR0](#), are used to access the SATA port registers.

Table 112. Configuration Space Comparison

In PCI IDE Mode	In Direct Port Access Mode	Offset
SU Base Address Register 0 - SUBAR0	SU PCI DPA Base Address Register 0 - SUDBAR0	10H
SU Base Address Register 1 - SUBAR1	SU PCI DPA Upper Base Address Register 0 - SUPDUBAR0	14H
SU Base Address Register 2 - SUBAR2	Reserved	18H
SU Base Address Register 3 - SUBAR3	Reserved	1CH
SU Base Address Register 4 - SUBAR4	Reserved	20H
SU Base Address Register 5 - SUBAR5	Reserved	24H

Table 113 shows the SATA port registers. Each SATA port consumes 512 bytes of address space. The Common Port Registers consume 512 bytes. All four SATA ports and the Common Port Registers occupy 4 Kbytes of address space. The SATA port registers are defined in Section 5.10.8, “SU PCI DPA Mode Common SATA Port Registers” on page 194 through Section 5.10.12, “SU PCI DPA Mode Superset Registers” on page 220.

Table 113. SATA Port Registers Mapping in PCI DPA Mode (Sheet 1 of 7)

Register Name	Offset
SU PCI DPA Interrupt Pending Register - SUPDIPR	000H
SU PCI DPA Interrupt Mask Register - SUPDIMR	004H
Reserved.	008H - 1FFH
SU PCI DPA Data Port Register - SUPDDR	Port 0 - 200H Port 1 - 400H Port 2 - 600H Port 3 - 800H
SU PCI DPA Error Register - SUPDER	Port 0 - 204H Port 1 - 404H Port 2 - 604H Port 3 - 804H
SU PCI DPA Features Register - SUPDFR	Port 0 - 206H Port 1 - 406H Port 2 - 606H Port 3 - 806H
SU PCI DPA Sector Count Register - SUPDSCR	Port 0 - 208H Port 1 - 408H Port 2 - 608H Port 3 - 808H
SU PCI DPA Sector Number Register - SUPDSNR	Port 0 - 20CH Port 1 - 40CH Port 2 - 60CH Port 3 - 80CH
SU PCI DPA Cylinder Low Register - SUPDCLR	Port 0 - 210H Port 1 - 410H Port 2 - 610H Port 3 - 810H
SU PCI DPA Cylinder High Register - SUPDCHR	Port 0 - 214H Port 1 - 414H Port 2 - 614H Port 3 - 814H
SU PCI DPA Device/Head Register - SUPDDHR	Port 0 - 218H Port 1 - 418H Port 2 - 618H Port 3 - 818H
SU PCI DPA Status Register - SUPDSR	Port 0 - 21CH Port 1 - 41CH Port 2 - 61CH Port 3 - 81CH

Table 113. SATA Port Registers Mapping in PCI DPA Mode (Sheet 2 of 7)

Register Name	Offset
SU PCI DPA Command Register - SUPDCR	Port 0 - 21DH Port 1 - 41DH Port 2 - 61DH Port 3 - 81DH
Reserved.	Port 0 - 220H - 227H Port 1 - 420H - 427H Port 2 - 620H - 627H Port 3 - 820H - 827H
SU PCI DPA Alternate Status Register - SUPDASR	Port 0 - 228H Port 1 - 428H Port 2 - 628H Port 3 - 828H
SU PCI DPA Device Control Register - SUPDDCTLR	Port 0 - 229H Port 1 - 429H Port 2 - 629H Port 3 - 829H
Reserved.	Port 0 - 22CH - 25FH Port 1 - 42CH - 42FH Port 2 - 62CH - 62FH Port 3 - 82CH - 82FH
Reserved.	Port 0 - 260H Port 1 - 460H Port 2 - 660H Port 3 - 860H
SU PCI DPA Upper DMA Descriptor Table Pointer Register - SUPDUDDTPR	Port 0 - 264H Port 1 - 464H Port 2 - 664H Port 3 - 864H
Reserved.	Port 0 - 268H Port 1 - 468H Port 2 - 668H Port 3 - 868H
SU PCI DPA Upper DMA Data Buffer Pointer Register - SUPDUDDPR.	Port 0 - 26CH Port 1 - 46CH Port 2 - 66CH Port 3 - 86CH
SU PCI DPA DMA Command Register - SUPDDCMDR	Port 0 - 270H Port 1 - 470H Port 2 - 670H Port 3 - 870H
SU PCI DPA DMA Status Register - SUPDDSR	Port 0 - 272H Port 1 - 472H Port 2 - 672H Port 3 - 872H

Table 113. SATA Port Registers Mapping in PCI DPA Mode (Sheet 3 of 7)

Register Name	Offset
SU PCI DPA DMA Descriptor Table Pointer Register - SUPDDDTPR	Port 0 - 274H Port 1 - 474H Port 2 - 674H Port 3 - 874H
Reserved.	Port 0 - 278H - 2FFH Port 1 - 478H - 4FFH Port 2 - 678H - 6FFH Port 3 - 878H - 8FFH
SU PCI DPA SATA SStatus Register - SUPDSSSR	Port 0 - 300H Port 1 - 500H Port 2 - 700H Port 3 - 900H
SU PCI DPA SATA SError Register - SUPDSSER	Port 0 - 304H Port 1 - 504H Port 2 - 704H Port 3 - 904H
SU PCI DPA SATA SControl Register - SUPDSSCR	Port 0 - 308H Port 1 - 508H Port 2 - 708H Port 3 - 908H
SU PCI DPA Set Device Bits Register - SUPDSDBR	Port 0 - 30CH Port 1 - 50CH Port 2 - 70CH Port 3 - 90CH
Reserved.	Port 0 - 310H - 33FH Port 1 - 510H - 53FH Port 2 - 710H - 73FH Port 3 - 910H - 93FH
SU PCI DPA PHY Feature Register - SUPDPFR	Port 0 - 340H Port 1 - 540H Port 2 - 740H Port 3 - 940H
SU PCI DPA BIST FIS Control and Status Register - SUPDBFCSR	Port 0 - 344H Port 1 - 544H Port 2 - 744H Port 3 - 944H
SU PCI DPA BIST Errors Register - SUPDBER	Port 0 - 348H Port 1 - 548H Port 2 - 748H Port 3 - 948H
SU PCI DPA BIST Frames Register - SUPDBFR	Port 0 - 34CH Port 1 - 54CH Port 2 - 74CH Port 3 - 94CH

Table 113. SATA Port Registers Mapping in PCI DPA Mode (Sheet 4 of 7)

Register Name	Offset
SU PCI DPA Host BIST Data Low Register - SUPDHBDLR	Port 0 - 350H Port 1 - 550H Port 2 - 750H Port 3 - 950H
SU PCI DPA Host BIST Data High Register - SUPDHBDHR	Port 0 - 354H Port 1 - 554H Port 2 - 754H Port 3 - 954H
SU PCI DPA Device BIST Data Low Register - SUPDDBDLR	Port 0 - 358H Port 1 - 558H Port 2 - 758H Port 3 - 958H
SU PCI DPA Device BIST Data High Register - SUPDDBDHR	Port 0 - 35CH Port 1 - 55CH Port 2 - 75CH Port 3 - 95CH
SU PCI DPA Queuing Table Base Address Register Low - SUPDQTBARL	Port 0 - 360H Port 1 - 560H Port 2 - 760H Port 3 - 960H
SU PCI DPA Queuing Table Base Address Register High - SUPDQTBARH	Port 0 - 364H Port 1 - 564H Port 2 - 764H Port 3 - 964H
SU PCI DPA DMA Setup FIS Control and Status Register - SUPDDSFCSR	Port 0 - 368H Port 1 - 568H Port 2 - 768H Port 3 - 968H
SU PCI DPA Host DMA Buffer Identifier Low Register - SUPDHDBILR	Port 0 - 36CH Port 1 - 56CH Port 2 - 76CH Port 3 - 96CH
SU PCI DPA Host DMA Buffer Identifier High Register - SUPDHDBIHR	Port 0 - 370H Port 1 - 570H Port 2 - 770H Port 3 - 970H
SU PCI DPA Host Reserved DWORD Register 0 - SUPDHRDR 0.	Port 0 - 374H Port 1 - 574H Port 2 - 774H Port 3 - 974H
SU PCI DPA Host DMA Buffer Offset Register - SUPDHDBOR	Port 0 - 378H Port 1 - 578H Port 2 - 778H Port 3 - 978H

Table 113. SATA Port Registers Mapping in PCI DPA Mode (Sheet 5 of 7)

Register Name	Offset
SU PCI DPA Host DMA Transfer Count Register - SUPDHDTCR	Port 0 - 37CH Port 1 - 57CH Port 2 - 77CH Port 3 - 87CH
SU PCI DPA Host Reserved DWORD Register 1- SUPDHRDR 1.	Port 0 - 380H Port 1 - 580H Port 2 - 780H Port 3 - 980H
SU PCI DPA Device DMA Buffer Identifier Low Register - SUPDDBILR	Port 0 - 384H Port 1 - 584H Port 2 - 784H Port 3 - 984H
SU PCI DPA Device DMA Buffer Identifier High Register - SUPDDBIHR	Port 0 - 388H Port 1 - 588H Port 2 - 788H Port 3 - 988H
SU PCI DPA Device Reserved DWORD Register 0 - SUPDDRDR0	Port 0 - 38CH Port 1 - 58CH Port 2 - 78CH Port 3 - 98CH
SU PCI DPA Device DMA Buffer Offset Register - SUPDDBBOR	Port 0 - 390H Port 1 - 590H Port 2 - 790H Port 3 - 990H
SU PCI DPA Device DMA Transfer Count Register - SUPDDTCR	Port 0 - 394H Port 1 - 594H Port 2 - 794H Port 3 - 994H
Reserved Word	Port 0 - 398H Port 1 - 598H Port 2 - 798H Port 3 - 998H
Reserved Word	Port 0 - 39CH Port 1 - 59CH Port 2 - 79CH Port 3 - 99CH
Reserved Word	Port 0 - 3A0H Port 1 - 5A0H Port 2 - 7A0H Port 3 - 9A0H
Reserved Word	Port 0 - 3A4H Port 1 - 5A4H Port 2 - 7A4H Port 3 - 9A4H

Table 113. SATA Port Registers Mapping in PCI DPA Mode (Sheet 6 of 7)

Register Name	Offset
Reserved Word	Port 0 - 3A8H Port 1 - 5A8H Port 2 - 7A8H Port 3 - 9A8H
Reserved Word	Port 0 - 3ACH Port 1 - 5ACH Port 2 - 7ACH Port 3 - 9ACH
Reserved Word	Port 0 - 3B0H Port 1 - 5B0H Port 2 - 7B0H Port 3 - 9B0H
Reserved Word	Port 0 - 3B4H Port 1 - 5B4H Port 2 - 7B4H Port 3 - 9B4H
Reserved Word	Port 0 - 3B8H Port 1 - 5B8H Port 2 - 7B8H Port 3 - 9B8H
Reserved Word	Port 0 - 3BCH Port 1 - 5BCH Port 2 - 7BCH Port 3 - 9BCH
Reserved Word	Port 0 - 3C0H Port 1 - 5C0H Port 2 - 7C0H Port 3 - 9C0H
Reserved Word	Port 0 - 3C4H Port 1 - 5C4H Port 2 - 7C4H Port 3 - 9C4H
Reserved Word	Port 0 - 3C8H Port 1 - 5C8H Port 2 - 7C8H Port 3 - 9C8H
Test Register 0	Port 0 - 3CCH Port 1 - 5CCH Port 2 - 7CCH Port 3 - 9CCH



Table 113. SATA Port Registers Mapping in PCI DPA Mode (Sheet 7 of 7)

Register Name	Offset
Test Register 1	Port 0 - 3D0H Port 1 - 5D0H Port 2 - 7D0H Port 3 - 9D0H
Reserved.	Port 0 - 3D4H - 3FC Port 1 - 5D4H-5FC Port 2 - 7D4H - 7FC Port 3 - 9D4H -9FC

NOTE: Each SATA port occupy 512 Bytes of address space. Port 0, 1, 2, 3 are offset with respect to the Base Address Register 0 at 000H, 200H, 400H, and 600H respectively.

5.10.7 SU PCI DPA Mode Base Address Registers

This section defines the configuration registers that are different in PCI Direct Port Access mode.

5.10.7.1 SU PCI DPA Base Address Register 0 - SUPDBAR0

The SU PCI DPA Base Address Register 0 (SUDBAR0) together with the SU PCI DPA Upper Base Address Register 0 (SUDUBAR0) defines the block of memory addresses in which the SATA Ports registers are mapped.

Table 114. SU PCI DPA Base Address Register 0 - SUDBAR0

Bit	Default	Description
31:12	00000H	Base Address 0 - These bits define the actual location the SATA Unit is to respond to when addressed from the PCI bus.
11:04	00H	Reserved.
03	0 ₂	Prefetchable Indicator - When cleared, defines the memory space as non-prefetchable.
02:01	10 ₂	Type Indicator - Defines the width of the addressability for this memory window: 00 - Memory Window is locatable anywhere in 32 bit address space. 10 - Memory Window is locatable anywhere in 64 bit address space.
00	0 ₂	Memory Space Indicator - This bit field describes memory or I/O space base address. The SATA Unit in Direct Port Access mode is mapped in Memory space, thus this bit must be zero.

PCI Configuration Address Offset
10H -13H

Attribute Legend:
 RW = Read/Write
 RV = Reserved
 PR = Preserved
 RS = Read/Set
 RC = Read Clear
 RO = Read Only
 NA = Not Accessible

5.10.7.2 SU PCI DPA Upper Base Address Register 0 - SUPDUBAR0

This SU PCI DPA Upper Base Address Register (SUPDUBAR0) contains the upper base address when decoding PCI addresses beyond 4 Gbytes. Together with the SU PCI DPA Base Address Register 0 (SUPDBAR0), this register defines the actual location the SATA Unit responds to when addressed from the PCI bus for addresses > 4 Gbytes (for DACs).

The programmed value within the base address register must comply with the PCI programming requirements for address alignment. Refer to the *PCI Local Bus Specification*, Revision 2.2 for additional information on programming base address registers.

Table 115. SU PCI DPA Upper Base Address Register 0 - SUPDUBAR0

Bit	Default	Description
31:00	0000_0000H	Upper Base Address 0 - Together with Base Address 0 these bits define the actual location the SATA Unit is to respond to when addressed from the PCI bus for addresses > 4 Gbytes.

5.10.8 SU PCI DPA Mode Common SATA Port Registers

This section defines registers that are common to all the four SATA Ports.

5.10.8.1 SU PCI DPA Interrupt Pending Register - SUPDIPR

The SU PCI DPA Interrupt Pending Register is a 32-bit read-only register. This register is used to report interrupts generated by the SATA ports. Software must clear any pending interrupt at the appropriate sources. The IDE interrupts (bits 31, 23, 15, 7) are cleared by reading the SATA Port Command Block Status register. Other pending interrupts in this register are generated by the SError registers, and must be cleared by writing 1s to the SError registers.

Table 116. SU PCI DPA Interrupt Pending Register - SUPDIPR (Sheet 1 of 5)

Bit	Default	Description
31	0 ₂	SATA Port 3 IDE Interrupt - When set, this bit indicates that the SATA device generated an interrupt. This is the same as PCI IDE compatible interrupt. The source of this interrupt is based on the setting of the 'I' bit in the Device-to-Host Register FIS. This interrupt is cleared by reading the taskfile Status register.
30	0 ₂	SATA Port 3 CRC Error Detect Interrupt - When set, this bit indicates that a CRC error was detected on a previous data transfer. The source of this interrupt is from bit 21 (DIAG_C) of the SError register. This interrupt is cleared by writing a 1 to bit 21 of the SError register. Refer to Section 5.10.12.2, "SU PCI DPA SATA SError Register - SUPDSSER" on page 222.
29	0 ₂	SATA Port 3 Data Integrity Interrupt - When set, this bit indicates that a CRC, disparity error was detected by the host, or an R_ERR primitive was returned by the device in response to a Data FIS transfer. The source of this interrupt is from bit 8 (ERR_T) of the SError register. This interrupt is cleared by writing a 1 to bit 8 of the SError register. Refer to Section 5.10.12.2, "SU PCI DPA SATA SError Register - SUPDSSER" on page 222.
28	0 ₂	SATA Port 3 Unrecognized FIS Reception Interrupt - When set, this bit indicates that an unsupported FIS was detected. The source of this interrupt is from bit 10 (ERR_P) of the SError register. This interrupt is cleared by writing a 1 to bit 10 of the SError register. Refer to Section 5.10.12.2, "SU PCI DPA SATA SError Register - SUPDSSER" on page 222.
27	0 ₂	SATA Port 3 R_ERR Primitive Received Interrupt - When set, this bit indicates that an R_ERR primitive was received during a Data FIS transfer. The source of this interrupt is from bit 22 (DIAG_H) of the SError register. This interrupt is cleared by writing a 1 to bit 22 of the SError register. Refer to Section 5.10.12.2, "SU PCI DPA SATA SError Register - SUPDSSER" on page 222.
26	0 ₂	SATA Port 3 FIFO Error Interrupt - When set, a FIFO error occurred during a Data FIS transfer. The source of this interrupt is from bit 11 (ERR_E) of the SError register. This interrupt is cleared by writing a 1 to bit 11 of the SError register. Refer to Section 5.10.12.2, "SU PCI DPA SATA SError Register - SUPDSSER" on page 222.

Table 116. SU PCI DPA Interrupt Pending Register - SUPDIPR (Sheet 2 of 5)

Bit	Default	Description
25	0 ₂	SATA Port 3 PHY Ready Interrupt - When set, a SATA Port 0 PHY became READY from NOT READY. OOB is done. The source of this interrupt is from bit 1 (ERR_M) of the SError register. This interrupt is cleared by writing a 1 to bit 1 of the SError register. Refer to Section 5.10.12.2, "SU PCI DPA SATA SError Register - SUPDSSER" on page 222. The default value after reset is 0 ₂ , for example the PHY will not be ready. When the PHY becomes ready as part of the initialization sequence, the value will change to 1 ₂ .
24	0 ₂	SATA Port 3 PHY Change State Interrupt - When set, the PHY either went from READY to NOT-READY, or from NOT-READY to READY. The source of this interrupt is from bit 16 (DIAG_N) of the SError register. This interrupt is cleared by writing a 1 to bit 16 of the SError register. Refer to Section 5.10.12.2, "SU PCI DPA SATA SError Register - SUPDSSER" on page 222. The default value after reset is 0 ₂ , for example the PHY will not be ready. When the PHY becomes ready (state change from not-ready to ready) as part of the initialization sequence, the value will change to 1 ₂ .
23	0 ₂	SATA Port 2 IDE Interrupt - When set, this bit indicates that the SATA device generated an interrupt. This is the same as PCI IDE compatible interrupt. The source of this interrupt is based on the setting of the "I" bit in the Device-to-Host Register FIS. This interrupt is cleared by reading the taskfile Status register.
22	0 ₂	SATA Port 2 CRC Error Detect Interrupt - When set, this bit indicates that a CRC error was detected on a previous data transfer. The source of this interrupt is from bit 21 (DIAG_C) of the SError register. This interrupt is cleared by writing a 1 to bit 21 of the SError register. Refer to Section 5.10.12.2, "SU PCI DPA SATA SError Register - SUPDSSER" on page 222.
21	0 ₂	SATA Port 2 Data Integrity Interrupt - When set, this bit indicates that a CRC, disparity error was detected by the host, or an R_ERR was returned by the device in response to a Data FIS transfer. The source of this interrupt is from bit 8 (ERR_T) of the SError register. This interrupt is cleared by writing a 1 to bit 8 of the SError register. Refer to Section 5.10.12.2, "SU PCI DPA SATA SError Register - SUPDSSER" on page 222.
20	0 ₂	SATA Port 2 Unrecognized FIS Reception Interrupt - When set, this bit indicates that an unsupported FIS was detected. The source of this interrupt is from bit 10 (ERR_P) of the SError register. This interrupt is cleared by writing a 1 to bit 10 of the SError register. Refer to Section 5.10.12.2, "SU PCI DPA SATA SError Register - SUPDSSER" on page 222.
19	0 ₂	SATA Port 2 R_ERR Primitive Received Interrupt - When set, this bit indicates that an R_ERR primitive was received during a Data FIS transfer. The source of this interrupt is from bit 22 (DIAG_H) of the SError register. This interrupt is cleared by writing a 1 to bit 22 of the SError register. Refer to Section 5.10.12.2, "SU PCI DPA SATA SError Register - SUPDSSER" on page 222.
18	0 ₂	SATA Port 2 FIFO Error Interrupt - When set, a FIFO error occurred during a Data FIS transfer. The source of this interrupt is from bit 11 (ERR_E) of the SError register. This interrupt is cleared by writing a 1 to bit 11 of the SError register. Refer to Section 5.10.12.2, "SU PCI DPA SATA SError Register - SUPDSSER" on page 222.
17	0 ₂	SATA Port 2 PHY Ready Interrupt - When set, a SATA Port 0 PHY became READY from NOT READY. OOB is done. The source of this interrupt is from bit 1 (ERR_M) of the SError register. This interrupt is cleared by writing a 1 to bit 1 of the SError register. Refer to Section 5.10.12.2, "SU PCI DPA SATA SError Register - SUPDSSER" on page 222. The default value after reset is 0 ₂ , for example the PHY will not be ready. When the PHY becomes ready as part of the initialization sequence, the value will change to 1 ₂ .

Table 116. SU PCI DPA Interrupt Pending Register - SUPDIPR (Sheet 2 of 5)

		DPA Mode BAR0 Offset 000H	
		Attribute Legend: RW = Read/Write RV = Reserved PR = Preserved RS = Read/Set RC = Read Clear RO = Read Only NA = Not Accessible	
Bit	Default	Description	
25	0 ₂	SATA Port 3 PHY Ready Interrupt - When set, a SATA Port 0 PHY became READY from NOT READY. OOB is done. The source of this interrupt is from bit 1 (ERR_M) of the SError register. This interrupt is cleared by writing a 1 to bit 1 of the SError register. Refer to Section 5.10.12.2, "SU PCI DPA SATA SError Register - SUPDSSER" on page 222. The default value after reset is 0 ₂ , for example the PHY will not be ready. When the PHY becomes ready as part of the initialization sequence, the value will change to 1 ₂ .	
24	0 ₂	SATA Port 3 PHY Change State Interrupt - When set, the PHY either went from READY to NOT-READY, or from NOT-READY to READY. The source of this interrupt is from bit 16 (DIAG_N) of the SError register. This interrupt is cleared by writing a 1 to bit 16 of the SError register. Refer to Section 5.10.12.2, "SU PCI DPA SATA SError Register - SUPDSSER" on page 222. The default value after reset is 0 ₂ , for example the PHY will not be ready. When the PHY becomes ready (state change from not-ready to ready) as part of the initialization sequence, the value will change to 1 ₂ .	
23	0 ₂	SATA Port 2 IDE Interrupt - When set, this bit indicates that the SATA device generated an interrupt. This is the same as PCI IDE compatible interrupt. The source of this interrupt is based on the setting of the "I" bit in the Device-to-Host Register FIS. This interrupt is cleared by reading the taskfile Status register.	
22	0 ₂	SATA Port 2 CRC Error Detect Interrupt - When set, this bit indicates that a CRC error was detected on a previous data transfer. The source of this interrupt is from bit 21 (DIAG_C) of the SError register. This interrupt is cleared by writing a 1 to bit 21 of the SError register. Refer to Section 5.10.12.2, "SU PCI DPA SATA SError Register - SUPDSSER" on page 222.	
21	0 ₂	SATA Port 2 Data Integrity Interrupt - When set, this bit indicates that a CRC, disparity error was detected by the host, or an R_ERR was returned by the device in response to a Data FIS transfer. The source of this interrupt is from bit 8 (ERR_T) of the SError register. This interrupt is cleared by writing a 1 to bit 8 of the SError register. Refer to Section 5.10.12.2, "SU PCI DPA SATA SError Register - SUPDSSER" on page 222.	
20	0 ₂	SATA Port 2 Unrecognized FIS Reception Interrupt - When set, this bit indicates that an unsupported FIS was detected. The source of this interrupt is from bit 10 (ERR_P) of the SError register. This interrupt is cleared by writing a 1 to bit 10 of the SError register. Refer to Section 5.10.12.2, "SU PCI DPA SATA SError Register - SUPDSSER" on page 222.	
19	0 ₂	SATA Port 2 R_ERR Primitive Received Interrupt - When set, this bit indicates that an R_ERR primitive was received during a Data FIS transfer. The source of this interrupt is from bit 22 (DIAG_H) of the SError register. This interrupt is cleared by writing a 1 to bit 22 of the SError register. Refer to Section 5.10.12.2, "SU PCI DPA SATA SError Register - SUPDSSER" on page 222.	
18	0 ₂	SATA Port 2 FIFO Error Interrupt - When set, a FIFO error occurred during a Data FIS transfer. The source of this interrupt is from bit 11 (ERR_E) of the SError register. This interrupt is cleared by writing a 1 to bit 11 of the SError register. Refer to Section 5.10.12.2, "SU PCI DPA SATA SError Register - SUPDSSER" on page 222.	
17	0 ₂	SATA Port 2 PHY Ready Interrupt - When set, a SATA Port 0 PHY became READY from NOT READY. OOB is done. The source of this interrupt is from bit 1 (ERR_M) of the SError register. This interrupt is cleared by writing a 1 to bit 1 of the SError register. Refer to Section 5.10.12.2, "SU PCI DPA SATA SError Register - SUPDSSER" on page 222. The default value after reset is 0 ₂ , for example the PHY will not be ready. When the PHY becomes ready as part of the initialization sequence, the value will change to 1 ₂ .	

Table 116. SU PCI DPA Interrupt Pending Register - SUPDIPR (Sheet 3 of 5)

Bit	Default	Description
16	0 ₂	SATA Port 2 PHY Change State Interrupt - When set, the PHY either went from READY to NOT-READY, or from NOT-READY to READY. The source of this interrupt is from bit 16 (DIAG_N) of the SError register. This interrupt is cleared by writing a 1 to bit 16 of the SError register. Refer to Section 5.10.12.2, "SU PCI DPA SATA SError Register - SUPDSSER" on page 222. The default value after reset is 0 ₂ , for example the PHY will not be ready. When the PHY becomes ready (state change from not-ready to ready) as part of the initialization sequence, the value will change to 1 ₂ .
15	0 ₂	SATA Port 1 IDE Interrupt - When set, this bit indicates that the SATA device generated an interrupt. This is the same as PCI IDE compatible interrupt. The source of this interrupt is based on the setting of the "I" bit in the Device-to-Host Register FIS. This interrupt is cleared by reading the taskfile Status register.
14	0 ₂	SATA Port 1 CRC Error Detect Interrupt - When set, this bit indicates that a CRC error was detected on a previous data transfer. The source of this interrupt is from bit 21 (DIAG_C) of the SError register. This interrupt is cleared by writing a 1 to bit 21 of the SError register. Refer to Section 5.10.12.2, "SU PCI DPA SATA SError Register - SUPDSSER" on page 222.
13	0 ₂	SATA Port 1 Data Integrity Interrupt - When set, this bit indicates that a CRC, disparity error was detected by the host, or an R_ERR primitive was returned by the device in response to a Data FIS transfer. The source of this interrupt is from bit 8 (ERR_T) of the SError register. This interrupt is cleared by writing a 1 to bit 8 of the SError register. Refer to Section 5.10.12.2, "SU PCI DPA SATA SError Register - SUPDSSER" on page 222.
12	0 ₂	SATA Port 1 Unrecognized FIS Reception Interrupt - When set, this bit indicates that an unsupported FIS was detected. The source of this interrupt is from bit 10 (ERR_P) of the SError register. This interrupt is cleared by writing a 1 to bit 10 of the SError register. Refer to Section 5.10.12.2, "SU PCI DPA SATA SError Register - SUPDSSER" on page 222.
11	0 ₂	SATA Port 1 R_ERR Primitive Received Interrupt - When set, this bit indicates that an R_ERR primitive was received during a Data FIS transfer. The source of this interrupt is from bit 22 (DIAG_H) of the SError register. This interrupt is cleared by writing a 1 to bit 22 of the SError register. Refer to Section 5.10.12.2, "SU PCI DPA SATA SError Register - SUPDSSER" on page 222.
10	0 ₂	SATA Port 1 FIFO Error Interrupt - When set, a FIFO error occurred during a Data FIS transfer. The source of this interrupt is from bit 11 (ERR_E) of the SError register. This interrupt is cleared by writing a 1 to bit 11 of the SError register. Refer to Section 5.10.12.2, "SU PCI DPA SATA SError Register - SUPDSSER" on page 222.
09	0 ₂	SATA Port 1 PHY Ready Interrupt - When set, a SATA Port 0 PHY became READY from NOT READY. OOB is done. The source of this interrupt is from bit 1 (ERR_M) of the SError register. This interrupt is cleared by writing a 1 to bit 1 of the SError register. Refer to Section 5.10.12.2, "SU PCI DPA SATA SError Register - SUPDSSER" on page 222. The default value after reset is 0 ₂ , for example the PHY will not be ready. When the PHY becomes ready as part of the initialization sequence, the value will change to 1 ₂ .

Table 116. SU PCI DPA Interrupt Pending Register - SUPDIPR (Sheet 4 of 5)

Bit	Default	Description
08	0 ₂	SATA Port 1 PHY Change State Interrupt - When set, the PHY either went from READY to NOT-READY, or from NOT-READY to READY. The source of this interrupt is from bit 16 (DIAG_N) of the SError register. This interrupt is cleared by writing a 1 to bit 16 of the SError register. Refer to Section 5.10.12.2, "SU PCI DPA SATA SError Register - SUPDSSER" on page 222. The default value after reset is 0 ₂ , for example the PHY will not be ready. When the PHY becomes ready (state change from not-ready to ready) as part of the initialization sequence, the value will change to 1 ₂ .
07	0 ₂	SATA Port 0 IDE Interrupt - When set, this bit indicates that the SATA device generated an interrupt. This is the same as PCI IDE compatible interrupt. The source of this interrupt is based on the setting of the "I" bit in the Device-to-Host Register FIS. This interrupt is cleared by reading the taskfile Status register.
06	0 ₂	SATA Port 0 CRC Error Detect Interrupt - When set, this bit indicates that a CRC error was detected on a previous data transfer. The source of this interrupt is from bit 21 (DIAG_C) of the SError register. This interrupt is cleared by writing a 1 to bit 21 of the SError register. Refer to Section 5.10.12.2, "SU PCI DPA SATA SError Register - SUPDSSER" on page 222.
05	0 ₂	SATA Port 0 Data Integrity Interrupt - When set, this bit indicates that a CRC, disparity error was detected by the host, or an R_ERR primitive was returned by the device in response to a Data FIS transfer. The source of this interrupt is from bit 8 (ERR_T) of the SError register. This interrupt is cleared by writing a 1 to bit 8 of the SError register. Refer to Section 5.10.12.2, "SU PCI DPA SATA SError Register - SUPDSSER" on page 222.
04	0 ₂	SATA Port 0 Unrecognized FIS Reception Interrupt - When set, this bit indicates that an unsupported FIS was detected. The source of this interrupt is from bit 10 (ERR_P) of the SError register. This interrupt is cleared by writing a 1 to bit 10 of the SError register. Refer to Section 5.10.12.2, "SU PCI DPA SATA SError Register - SUPDSSER" on page 222.
03	0 ₂	SATA Port 0 R_ERR Received Interrupt - When set, this bit indicates that an R_ERR primitive was received during a Data FIS transfer. The source of this interrupt is from bit 22 (DIAG_H) of the SError register. This interrupt is cleared by writing a 1 to bit 22 of the SError register. Refer to Section 5.10.12.2, "SU PCI DPA SATA SError Register - SUPDSSER" on page 222.
02	0 ₂	SATA Port 0 FIFO Error Interrupt - When set, a FIFO error occurred during a Data FIS transfer. The source of this interrupt is from bit 11 (ERR_E) of the SError register. This interrupt is cleared by writing a 1 to bit 11 of the SError register. Refer to Section 5.10.12.2, "SU PCI DPA SATA SError Register - SUPDSSER" on page 222.
01	0 ₂	SATA Port 0 PHY Ready Interrupt - When set, a SATA Port 0 PHY became READY from NOT READY. OOB is done. The source of this interrupt is from bit 1 (ERR_M) of the SError register. This interrupt is cleared by writing a 1 to bit 1 of the SError register. Refer to Section 5.10.12.2, "SU PCI DPA SATA SError Register - SUPDSSER" on page 222. The default value after reset is 0 ₂ , for example the PHY will not be ready. When the PHY becomes ready as part of the initialization sequence, the value will change to 1 ₂ .

Table 116. SU PCI DPA Interrupt Pending Register - SUPDIPR (Sheet 5 of 5)

<p style="text-align: center;">DPA Mode BAR0 Offset 000H</p> <p style="text-align: right;">Attribute Legend: RW = Read/Write RV = Reserved RC = Read Clear PR = Preserved RO = Read Only RS = Read/Set NA = Not Accessible</p>		
Bit	Default	Description
00	0 ₂	<p>SATA Port 0 PHY Change State Interrupt - When set, the PHY either went from READY to NOT-READY, or from NOT-READY to READY. The source of this interrupt is from bit 16 (DIAG_N) of the SError register. This interrupt is cleared by writing a 1 to bit 16 of the SError register. Refer to Section 5.10.12.2, "SU PCI DPA SATA SError Register - SUPDSSER" on page 222.</p> <p>The default value after reset is 0₂, for example the PHY will not be ready. When the PHY becomes ready (state change from not-ready to ready) as part of the initialization sequence, the value will change to 1₂.</p>

5.10.8.2 SU PCI DPA Interrupt Mask Register - SUPDIMR

The SU PCI DPA Interrupt Mask Register is a 32-bit register. This register is used to mask interrupts pending in the SU PCI DPA Interrupt Pending Register. Each bit in the SU PCI DPA Interrupt Mask Register corresponds to a bit in the SU PCI DPA Interrupt Pending Register. Refer to Section 5.10.8.1, “SU PCI DPA Interrupt Pending Register - SUPDIPR” on page 194.

Table 117. SU PCI DPA Interrupt Mask Register - SUPDIMR (Sheet 1 of 3)

Bit	Default	Description
31	1 ₂	SATA Port 3 IDE Interrupt Mask Bit. 0 = Masked 1 = Not Masked
30	0 ₂	SATA Port 3 Signal Detect Interrupt Mask Bit. 0 = Masked 1 = Not Masked
29	0 ₂	SATA Port 3 Data Integrity Interrupt Mask Bit. 0 = Masked 1 = Not Masked
28	0 ₂	SATA Port 3 Unrecognized FIS Reception Interrupt Mask Bit. 0 = Masked 1 = Not Masked
27	0 ₂	SATA Port 3 R_ERR Primitive Received Interrupt Mask Bit. 0 = Masked 1 = Not Masked
26	0 ₂	SATA Port 3 FIFO Error Interrupt Mask Bit. 0 = Masked 1 = Not Masked
25	0 ₂	SATA Port 3 PHY Ready Interrupt Mask Bit. 0 = Masked 1 = Not Masked
24	0 ₂	SATA Port 3 PHY Change State Interrupt Mask Bit. 0 = Masked 1 = Not Masked
23	1 ₂	SATA Port 2 IDE Interrupt Mask Bit. 0 = Masked 1 = Not Masked
22	0 ₂	SATA Port 2 Signal Detect Interrupt Mask Bit. 0 = Masked 1 = Not Masked

Table 117. SU PCI DPA Interrupt Mask Register - SUPDIMR (Sheet 2 of 3)

Bit	Default	Description
21	0 ₂	SATA Port 2 Data Integrity Interrupt Mask Bit. 0 = Masked 1 = Not Masked
20	0 ₂	SATA Port 2 Unrecognized FIS Reception Interrupt Mask Bit. 0 = Masked 1 = Not Masked
19	0 ₂	SATA Port 2 R_ERR Primitive Received Interrupt Mask Bit. 0 = Masked 1 = Not Masked
18	0 ₂	SATA Port 2 FIFO Error Interrupt Mask Bit. 0 = Masked 1 = Not Masked
17	0 ₂	SATA Port 2 PHY Ready Interrupt Mask Bit. 0 = Masked 1 = Not Masked
16	0 ₂	SATA Port 2 PHY Change State Interrupt Mask Bit. 0 = Masked 1 = Not Masked
15	1 ₂	SATA Port 1 IDE Interrupt Mask Bit. 0 = Masked 1 = Not Masked
14	0 ₂	SATA Port 1 Signal Detect Interrupt Mask Bit. 0 = Masked 1 = Not Masked
13	0 ₂	SATA Port 1 Data Integrity Interrupt Mask Bit. 0 = Masked 1 = Not Masked
12	0 ₂	SATA Port 1 Unrecognized FIS Reception Interrupt Mask Bit. 0 = Masked 1 = Not Masked
11	0 ₂	SATA Port 1 R_ERR Primitive Received Interrupt Mask Bit. 0 = Masked 1 = Not Masked
10	0 ₂	SATA Port 1 FIFO Error Interrupt Mask Bit. 0 = Masked 1 = Not Masked

Table 117. SU PCI DPA Interrupt Mask Register - SUPDIMR (Sheet 3 of 3)

Bit	Default	Description
09	0 ₂	SATA Port 1 PHY Ready Interrupt Mask Bit. 0 = Masked 1 = Not Masked
08	0 ₂	SATA Port 1 PHY Change State Interrupt Mask Bit. 0 = Masked 1 = Not Masked
07	1 ₂	SATA Port 0 IDE Interrupt Mask Bit. 0 = Masked 1 = Not Masked
06	0 ₂	SATA Port 0 Signal Detect Interrupt Mask Bit. 0 = Masked 1 = Not Masked
05	0 ₂	SATA Port 0 Data Integrity Interrupt Mask Bit. 0 = Masked 1 = Not Masked
04	0 ₂	SATA Port 0 Unrecognized FIS Reception Interrupt Mask Bit. 0 = Masked 1 = Not Masked
03	0 ₂	SATA Port 0 R_ERR Primitive Received Interrupt Mask Bit. 0 = Masked 1 = Not Masked
02	0 ₂	SATA Port 0 FIFO Error Interrupt Mask Bit. 0 = Masked 1 = Not Masked
01	0 ₂	SATA Port 0 PHY Ready Interrupt Mask Bit. 0 = Masked 1 = Not Masked
00	0 ₂	SATA Port 0 PHY Change State Interrupt Mask Bit. 0 = Masked 1 = Not Masked

<p>DPA Mode BAR0 Offset 004H</p>		<p>Attribute Legend: RV = Reserved PR = Preserved RS = Read/Set</p>	<p>RW = Read/Write RC = Read Clear RO = Read Only NA = Not Accessible</p>
--------------------------------------	--	---	---

5.10.9 SU PCI DPA Mode Command Block Registers

This section defines the Command Block Registers when in DPA mode.

5.10.9.1 SU PCI DPA Data Port Register - SUPDDR

The SU PCI DPA Data Port Register is a 16-bit read/write register and is used to transfer data during Programmed I/O (PIO) mode reads/writes. On the GD31244 controller, the Data Port register may also be read or written as a 32-bit Data Port. The GD31244 controller internally breaks the 32-bit transaction into two back-to-back 16-bit transactions. It is recommended that the Data Port register is always accessed with either 16-bit or 32-bit quantity for a given PIO sequence. Refer to the *AT Attachment with Packet Interface-6 (ATA/ATAPI-6) Specification*.

Table 118. SU PCI DPA Data Port Register - SUPDDR

Bit	Default	Description
15:00	0000H	Data Port - This register is used to transfer data during PIO reads and writes. This register shall be accessed only when the DRQ bit in the SU PCI DPA Status Register - SUPDSR is set.

5.10.9.2 SU PCI DPA Error Register - SUPDER

The SU PCI DPA Error Register is a 8-bit read-only register. The SU PCI DPA Error Register contains error status for the current command. The content of this register shall be valid when the ERR bit is set in the [SU PCI DPA Status Register - SUPDSR](#). The SU PCI DPA Error Register is command dependent and the bits are defined in the *ATA Attachment with Packet Interface-6 (ATA/ATAPI-6) Specification*.

Table 119. SU PCI DPA Error Register - SUPDER

DPA Mode BAR0 Offset Port 0 = 204H, Port 1 = 404H Port 2 = 604H, Port 3 = 804H		Attribute Legend: RV = Reserved PR = Preserved RS = Read/Set RW = Read/Write RC = Read Clear RO = Read Only NA = Not Accessible
Bit	Default	Description
07:00	Device Dependent ^a	The bits in this register are command dependent. The bits are only valid when the ERR bit (bit 0) in the SU PCI DPA Status Register - SUPDSR is set. Refer to the <i>ATA Attachment with Packet Interface-6 (ATA/ATAPI-6) Specification</i> .

a. After a hardware reset, software reset, or an EXECUTE DEVICE DIAGNOSTIC command, the device will return a diagnostic code. The diagnostic code is device dependent. Refer to the *ATA Attachment with Packet Interface-6 (ATA/ATAPI-6) Specification*.

5.10.9.3 SU PCI DPA Features Register - SUPDFR

The SU PCI DPA Features Register is a 16-bit register. The content of the SU PCI DPA Features Register is a command parameter. The content of this register must be loaded before the SU PCI DPA Command Register is written. The content of the SU PCI DPA Features Register is command dependent. Refer to the *AT Attachment with Packet Interface-6 (ATA/ATAPI-6) Specification*.

Table 120. SU PCI DPA Features Register - SUPDFR

<p>DPA Mode BAR0 Offset Port 0 = 206H, Port 1 = 406H Port 2 = 606H, Port 3 = 806H</p>		
<p>Attribute Legend: RW = Read/Write RV = Reserved PR = Preserved RS = Read/Set WO = Write Only</p>		
<p>RW = Read/Write RC = Read Clear RO = Read Only NA = Not Accessible</p>		
Bit	Default	Description
15:00	00H	Features - This register is command dependent. For example, it may be a parameter as an extension to the IDE Command Register.

5.10.9.4 SU PCI DPA Sector Count Register - SUPDSCR

The SU PCI DPA Sector Count Register is a 16-bit read/write register. The content of the SU PCI DPA Sector Count Register is a command parameter. The content of this register must be loaded before the SU PCI DPA Command Register is written. The content of the SU PCI DPA Sector Count Register is command dependent. Refer to the *ATA Attachment with Packet Interface-6 (ATA/ATAPI-6) Specification*.

Table 121. SU PCI DPA Sector Count Register - SUPDSCR

Bit	Default	Description
15:00	Device Dependent ^a	Sector Count/LBA Low: <ul style="list-style-type: none"> • CHS addressing - only the lower byte is used for specifying a sector count. • 28-bit LBA addressing - only the lower byte is used for specifying a sector count. • 48-bit LBA addressing - a 16-bit value is used for specifying a sector count.

a. After a hardware reset, software reset, or an EXECUTE DEVICE DIAGNOSTIC command, the device will return a signature value. The signature value is device dependent. Refer to the *ATA Attachment with Packet Interface-6 (ATA/ATAPI-6) Specification*.

5.10.9.5 SU PCI DPA Sector Number Register - SUPDSNR

The SU PCI DPA Sector Number Register is a 16-bit read/write register. The content of the SU PCI DPA Sector Number Register is a command parameter. The content of this register must be loaded before the SU PCI DPA Command Register is written. The content of this register is command dependent. Refer to the *AT Attachment with Packet Interface-6 (ATA/ATAPI-6) Specification*.

Table 122. SU PCI DPA Sector Number Register - SUPDSNR

<p>DPA Mode BAR0 Offset Port 0 = 20CH, Port 1 = 40CH Port 2 = 60CH, Port 3 = 80CH</p>		
<p>Attribute Legend: RW = Read/Write RV = Reserved RC = Read Clear PR = Preserved RO = Read Only RS = Read/Set NA = Not Accessible</p>		
Bit	Default	Description
15:00	Device Dependent ^a	<p>Sector Number/LBA Low- This field is dependent on the device access methods. There are three method:</p> <ul style="list-style-type: none"> • CHS addressing: This field indicates the device sector number to request as part of the Cylinder/Head/Sector format. • 28-bit LBA addressing: This lower eight bits of this field is used for bit positions LBA[7:0] of the 28-bit address LBA[27:0]. • 48-bit LBA addressing: This upper and lower bytes of this field is used for bit positions LBA[31:24] and LBA[7:0] respectively of the 48-bit addressing LBA[47:0].

a. After a hardware reset, software reset, or an EXECUTE DEVICE DIAGNOSTIC command, the device will return a signature value. The signature value is device dependent. Refer to the *AT Attachment with Packet Interface-6 (ATA/ATAPI-6) Specification*.

5.10.9.6 SU PCI DPA Cylinder Low Register - SUPDCLR

The SU PCI DPA Cylinder Low Register is a 16-bit read/write register. The content of the SU PCI DPA Cylinder Low Register is a command parameter. The content of this register must be loaded before the SU PCI DPA Command Register is written. The content of the SU PCI DPA Cylinder Low Register is command dependent. Refer to the *AT Attachment with Packet Interface-6 (ATA/ATAPI-6) Specification*.

Table 123. SU PCI DPA Cylinder Low Register - SUPDCLR

<p>DPA Mode BAR0 Offset Port 0 = 210H, Port 1 = 410H Port 2 = 610H, Port 3 = 810H</p>		
<p>Attribute Legend: RW = Read/Write RV = Reserved RC = Read Clear PR = Preserved RO = Read Only RS = Read/Set NA = Not Accessible</p>		
Bit	Default	Description
15:00	Device Dependent ^a	<p>Cylinder Low/LBA Mid - This field is dependent on the device access methods. There are three method:</p> <ul style="list-style-type: none"> CHS addressing: This field indicates the lower cylinder byte to request as part of the Cylinder/Head/Sector format. 28-bit LBA addressing: This lower eight bits of this field is used for bit positions LBA[15:8] of the 28-bit address LBA[27:0]. 48-bit LBA addressing: This upper and lower bytes of this field is used for bit positions LBA[39:32] and LBA[15:8] respectively of the 48-bit addressing LBA[47:0].

a. After a hardware reset, software reset, or an EXECUTE DEVICE DIAGNOSTIC command, the device will return a signature value. The signature value is device dependent. Refer to the *AT Attachment with Packet Interface-6 (ATA/ATAPI-6) Specification*.

5.10.9.7 SU PCI DPA Cylinder High Register - SUPDCHR

The SU PCI DPA Cylinder High Register is a 16-bit read/write register. The content of the SU PCI DPA Cylinder High Register is a command parameter. The content of this register must be loaded before the SU PCI DPA Command Register is written. The content of the SU PCI DPA Cylinder High Register is command dependent. Refer to the *ATA Attachment with Packet Interface-6 (ATA/ATAPI-6) Specification*.

Table 124. SU PCI DPA Cylinder High Register - SUPDCHR

<p>DPA Mode BAR0 Offset Port 0 = 214H, Port 1 = 414H Port 2 = 614H, Port 3 = 814H</p>		<p>Attribute Legend: RV = Reserved PR = Preserved RS = Read/Set</p>
		<p>RW = Read/Write RC = Read Clear RO = Read Only NA = Not Accessible</p>
Bit	Default	Description
15:00	Device Dependent ^a	<p>Cylinder High/LBA High - This field is dependent on the device access methods. There are three method:</p> <ul style="list-style-type: none"> CHS addressing: This field specifies the higher cylinder byte to request as part of the Cylinder/Head/Sector format. 28-bit LBA addressing: This lower eight bits of this field is used for bit positions LBA[23:16] of the 28-bit address LBA[27:0]. 48-bit LBA addressing: The upper and lower bytes of this field is used for bit positions LBA[47:40] and LBA[23:16] respectively of the 48-bit addressing LBA[47:0].

a. After a hardware reset, software reset, or an EXECUTE DEVICE DIAGNOSTIC command, the device will return a signature value. The signature value is device dependent. Refer to the *ATA Attachment with Packet Interface-6 (ATA/ATAPI-6) Specification*.

5.10.9.8 SU PCI DPA Device/Head Register - SUPDDR

This SU PCI DPA Device/Head Register is an 8-bit read/write register. The content of the SU PCI DPA Device/Head Register is a command parameter. The content of this register must be loaded before the SU PCI DPA Command Register is written. The content of the SU PCI DPA Device/Head Register is command dependent. Refer to the *ATA Attachment with Packet Interface-6 (ATA/ATAPI-6) Specification*.

Table 125. SU PCI DPA Device/Head Register - SUPDHR

Bit	Default	Description
07	Device Dependent ^a	Reserved
06		Logical Addressing Mode - This bit indicates the addressing mode: 0 = CHS Mode 1 = LBA Mode
05		Reserved
04		Reserved.
03:00		Head - This field is dependent on the device access methods. There are three methods: <ul style="list-style-type: none"> CHS addressing: this field indicates the head number for the Cylinder/Head/Sector format. 28-bit LBA addressing: This field is used for bit positions LBA[27:24] of the 28-bit addressing LBA[27:0]. 48-bit LBA Mode: These bit are not part of the 48-bit LBA address, but need to be set to 1111₂.

DPA Mode BAR0 Offset
Port 0 = 218H, Port 1 = 418H
Port 2 = 618H, Port 3 = 818H

Attribute Legend:

RW = Read/Write
RV = Reserved
PR = Preserved
RS = Read/Set
RC = Read Clear
RO = Read Only
NA = Not Accessible

a. After a hardware reset, software reset, or an EXECUTE DEVICE DIAGNOSTIC command, the device will return a signature value. The signature value is device dependent. Refer to the *ATA Attachment with Packet Interface-6 (ATA/ATAPI-6) Specification*.

5.10.9.9 SU PCI DPA Status Register - SUPDSR

The SU PCI DPA Status Register is an 8-bit read-only register. This register provides the status of the device and the interface. Reading this register implicitly clears any pending interrupt. Instead, the Alternate Status register may be used to read the status of a device without causing any pending interrupt to get cleared. Some of the bits in this register are command-dependent and are described in the *AT Attachment with Packet Interface-6 (ATA/ATAPI-6) Specification*. Information in this register is updated by the device sending a Device-to-Host Register FIS or PIO Setup FIS.

Table 126. SU PCI DPA Status Register - SUPDSR

Bit	Default	Description
07	Device Dependent ^a	BSY - When this bit is set the interface/device is busy. For example, the device may be working a previous command. This bit is set immediately after the Command register is written and a Host-to-Device Register FIS is sent to the device, indicating that the interface is busy. The device is then responsible to clear this bit by sending a PIO Setup FIS or Device-to-Host Register FIS.
06		DRDY - This bit when set indicates that the device is ready.
05		This bit is command dependent. Refer to the <i>AT Attachment with Packet Interface-6 (ATA/ATAPI-6) Specification</i> .
04		This bit is command dependent. Refer to the <i>AT Attachment with Packet Interface-6 (ATA/ATAPI-6) Specification</i> .
03		DRQ - This bit is set when the device is ready to transfer data for PIO transactions.
02		This bit is command dependent. Refer to the <i>AT Attachment with Packet Interface-6 (ATA/ATAPI-6) Specification</i> .
01		This bit is command dependent. Refer to the <i>AT Attachment with Packet Interface-6 (ATA/ATAPI-6) Specification</i> .
00		ERR - This bit when set indicates that an error occurred. The SU PCI DPA Error Register - SUPDER provides further error information.

a. After power-on, a value of 7FH is returned in this register when read before a device is detected on the serial link. This is consistent with the ATA standard, indicating that a device is not connected to the cable. After the device is detected and a communication link is established between the host and the device, a value of 80H will be read. Bit 7 (BSY bit) set indicates that the device has been detected, but is busy executing its initialization and diagnostics. After the device is done with its initialization and diagnostics sequence, it will send a Device-to-Host Register FIS with bit 7 (BSY bit) cleared.

5.10.9.10 SU PCI DPA Command Register - SUPDCR

The SU PCI DPA Command Register is an 8-bit register. A command is initiated by writing this register. Refer to the *AT Attachment with Packet Interface-6 (ATA/ATAPI-6) Specification*.

Table 127. SU PCI DPA Command Register - SUPDCR

DPA Mode BAR0 Offset Port 0 = 21DH, Port 1 = 41DH Port 2 = 61DH, Port 3 = 81DH		Attribute Legend: RV = Reserved PR = Preserved RS = Read/Set WO = Write Only
		RW = Read/Write RC = Read Clear RO = Read Only NA = Not Accessible
Bit	Default	Description
07:00	00H	Command - This register is used to initiate a command. This register must be written last. For example, it must be written after the other Command Block registers are written. Because the rest of the registers are parameters for the command.

5.10.10 SU PCI DPA Mode Control Block Registers

This section defines the Control Block Registers.

5.10.10.1 SU PCI DPA Alternate Status Register - SUPDASR

The SU PCI DPA Alternate Status Register is an 8-bit read-only register. This register contains the same information as the SU PCI DPA Status Register. The difference is that when this register is read, any pending interrupt is not cleared. Refer to the *AT Attachment with Packet Interface-6 (ATA/ATAPI-6) Specification*.

Table 128. SU PCI DPA Alternate Status Register - SUPDASR

<div style="text-align: center;"> </div>		
<p>DPA Mode BAR0 Offset Port 0 = 228H, Port 1 = 428H Port 2 = 628H, Port 3 = 828H</p>		
<p>Attribute Legend: RW = Read/Write RV = Reserved RC = Read Clear PR = Preserved RO = Read Only RS = Read/Set NA = Not Accessible</p>		
Bit	Default	Description
07:00	Refer to Table 126.	Alternate Status Register - This register contains the same information as in the IDE Status Register. The difference is that when this register is read, any pending interrupts are not cleared. Refer to Section 126, "SU PCI DPA Status Register - SUPDSR" on page 211.

5.10.10.2 SU PCI DPA Device Control Register - SUPDDCTLR

The SU PCI DPA Device Control Register is an 8-bit write-only register. The SU PCI DPA Device Control Register is used to initiate a software reset to the device. Refer to the *AT Attachment with Packet Interface-6 (ATA/ATAPI-6) Specification*.

Table 129. SU PCI DPA Device Control Register - SUPDDCTLR

DPA Mode BAR0 Offset Port 0 = 229H, Port 1 = 429H Port 2 = 629H, Port 3 = 829H		Attribute Legend: RV = Reserved PR = Preserved RS = Read/Set WO = Write Only	RW = Read/Write RC = Read Clear RO = Read Only NA = Not Accessible
Bit	Default	Description	
07	0 ₂	Reserved.	
06	0 ₂	Reserved.	
05	0 ₂	Reserved.	
04	0 ₂	Reserved.	
03	0 ₂	Reserved.	
02	0 ₂	SRST - This bit is used by software to perform a device reset. Writing a 1 requests the device to start the reset sequence, and writing a 0 request the device to terminate reset.	
01	0 ₂	Reserved.	
00	0 ₂	Reserved. This bit shall always be cleared.	

5.10.11 SU PCI DPA Mode DMA Registers

This section defines the DPA DMA Registers.

5.10.11.1 SU PCI DPA Upper DMA Descriptor Table Pointer Register - SUPDUDDTPR

The SU PCI DPA Upper DMA Descriptor Table Pointer Register contains the upper 32-bit PCI address of the 64-bit PCI address. In PCI IDE mode, the SU PCI DPA Upper DMA Descriptor Table Pointer Register is not used. This register allows the descriptor table to be located in any 4 Gbyte memory space.

Table 130. SU PCI DPA Upper DMA Descriptor Table Pointer Register - SUPDUDDTPR

Bit	Default	Description
31:00	0000 0000H	PCI Address - is the PCI source/destination upper address.

5.10.11.2 SU PCI DPA Upper DMA Data Pointer Register - SUPDUDBPR

This SU PCI DPA Upper DMA Data Pointer Register contains the upper 32-bit PCI address of the 64-bit PCI address. All the descriptors in the descriptor table share this register. For example, all the data buffers must be located in the same 4 Gbyte memory space.

Table 131. SU PCI DPA Upper DMA Data Buffer Pointer Register - SUPDUDDPR

DPA Mode BAR0 Offset Port 0 = 26CH, Port 1 = 46CH Port 2 = 66CH, Port 3 = 86CH		Attribute Legend: RV = Reserved PR = Preserved RS = Read/Set RW = Read/Write RC = Read Clear RO = Read Only NA = Not Accessible
Bit	Default	Description
31:00	0000 0000H	PCI Address - The PCI source/destination upper address.

5.10.11.3 SU PCI DPA DMA Command Register - SUPDDCMDR

The SU PCI DPA DMA Command Register enables/disables the DMA engine (bus master capability) and also provides direction control for DMA transfers.

Table 132. SU PCI DPA DMA Command Register - SUPDDCMDR

Bit	Default	Description
15:10	00H	Reserved
09	0 ₂	First Party DMA Direction: 0 = From Device to Host 1 = From Host to Device
08	0 ₂	First Party DMA Active: 0 = Not Active 1 = Active
07:04	0H	Reserved
03	0 ₂	DMA Read/Write Control: 0 = Reads Memory to write FIFO. FIFO data is written to SATA device. 1 = Writes Memory with FIFO data. FIFO contains data read from SATA device. This bit must NOT be changed when the DMA is active. While synchronous DMA transfer is in progress, this bit will be READ ONLY. The bit will return to read/write once the synchronous DMA transfer has been completed or halted.
02:01	00 ₂	Reserved.
00	0 ₂	Start/Stop DMA Transfer: 1 = Start; 0 = Stop. When this bit is set to 1, the DMA operation starts. The controller transfers data between the device and memory only while this bit is set. Operation may be stopped by writing a 0 to this bit. This results in all state information being lost (i.e., operation cannot be stop and then resumed). When this bit is set to 0 while bus master operation is still active (i.e., bit 0 = 1 in the DMA Status Register) and data transfer has not yet finished (i.e., bit 2 = 0 in the DMA Status Register), the DMA command is aborted and data transferred from the drive may be discarded by the SATA port rather than being written to memory. This bit is intended to be set to 0 after the data transfer is completed, as indicated by either bit 0 or bit 2 set in the DMA Status Register.

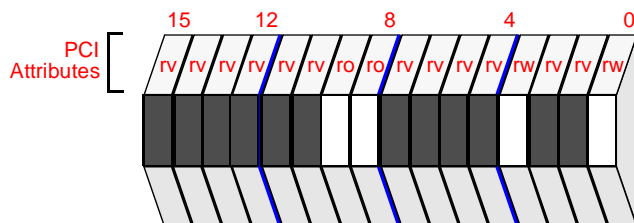

DPA Mode BAR0 Offset
Port 0 = 270H, Port 1 = 470H
Port 2 = 670H, Port 3 = 870H

Attribute Legend:
RV = Reserved
PR = Preserved
RS = Read/Set
RW = Read/Write
RC = Read Clear
RO = Read Only
NA = Not Accessible

5.10.11.4 SU PCI DPA DMA Status Register - SUPDDSR

The SU PCI DPA DMA Status Register provides status of the DMA engine.

Table 133. SU PCI DPA DMA Status Register - SUPDDSR

Bit	Default	Description
07	0 ₂	This bit is hardwired to 0. Simplex only.
06	0 ₂	Reserved.
05	1 ₂	DMA Capable: 1 = Capable of DMA transfers. This bit is a software controlled status bit that indicates DMA device capability and does not affect hardware operation.
04:03	00 ₂	Reserved.
02	0 ₂	Interrupt Status: This bit, when set to a 1, indicates when a device has asserted its interrupt line. When this bit is set to 1, all read data from the device has been transferred to memory and all write data has been transferred to the device. Software sets this bit to a 0 by writing a 1 to it.
01	0 ₂	DMA Error: This bit is set to 1 under the following conditions while transferring data on the PCI bus. <ul style="list-style-type: none"> Detected a master abort on the PCI bus Detected a target abort on the PCI bus Detected a parity error on the PCI bus Software sets this bit to 0 by writing a 1 to it.
00	0 ₂	DMA Active: The GD31244 controller sets this bit to 1 when bit 0 in the SU PCI DPA DMA Command Register is set to 1. Refer to Section 5.10.11.3, "SU PCI DPA DMA Command Register - SUPDDCMDR" on page 217 . The GD31244 controller sets this bit to 0 when the last transfer is performed (where EOT for that descriptor is set). The GD31244 controller also sets this bit to 0 when bit 0 of the IDE Channel 0 DMA Command Register is set to 0. When this bit is read as a 0, all data transferred from the drive during the previous bus master command is visible in memory, unless the DMA command was aborted.

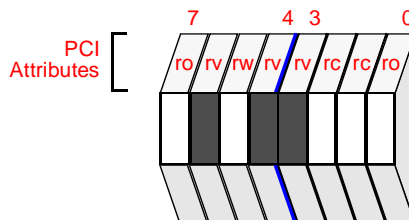

DPA Mode BAR0 Offset
Port 0 = 272H, Port 1 = 472H
Port 2 = 672H, Port 3 = 872H

Attribute Legend:
RW = Read/Write
RV = Reserved
RC = Read Clear
RO = Read Only
RS = Read/Set
NA = Not Accessible

5.10.11.5 SU PCI DPA DMA Descriptor Table Pointer Register - SUPDDTTPR

This SU PCI DPA DMA Descriptor Table Pointer Register contains the lower 32-bit PCI address. The SU PCI DPA DMA Descriptor Table Pointer Register points to system memory.

Table 134. SU PCI DPA DMA Descriptor Table Pointer Register - SUPDDTTPR

<p>DPA Mode BAR0 Offset Port 0 = 274H, Port 1 = 474H Port 2 = 674H, Port 3 = 874H</p>		<p>Attribute Legend: RV = Reserved RC = Read Clear PR = Preserved RO = Read Only RS = Read/Set NA = Not Accessible</p>
Bit	Default	Description
31:02	0000 0000H	PCI Address - is lower PCI address. This register contains the base address of the descriptor table. The descriptor table must be DWORD aligned and must not cross a 64 Kbyte boundary.
01:00	00 ₂	Reserved.

5.10.12 SU PCI DPA Mode Superset Registers

This section defines the Serial ATA Superset Registers. These registers provide control and status of the Serial ATA bus, and also support new Serial ATA specific commands.

5.10.12.1 SU PCI DPA SATA SStatus Register - SUPDSSSR

The SU PCI DPA SATA SStatus is a read-only register. The SU PCI DPA SATA SStatus Register provides status for the SATA interface itself, and conveys the interface state at the time it is read and is updated continuously and asynchronously. The SU PCI DPA SATA SStatus Register is one of the SCR Registers defined in the *Serial ATA/High-Speed Serialized AT Attachment*, Revision 1.0 RC-1.

Table 135. SU PCI DPA SATA SStatus Register - SUPDSSSR (Sheet 1 of 2)

Bit	Default	Description
31:12	0000_0H	Reserved
11:08	0000 ₂	<p>IPM - Interface Power Mode The IPM value indicates the current interface power management state</p> <p>0000₂ - Device is not present or communication has not been established</p> <p>0001₂ - Interface in active state</p> <p>0010₂ - Interface in PARTIAL power management state</p> <p>0110₂ - Interface in SLUMBER power management state</p> <p>All other values are reserved.</p> <p>The default value after reset is 0000₂. After communications between the host controller and the device is established, the value will change to reset 0001₂.</p>
07:04	0000 ₂	<p>SPD - The SPD value indicates the negotiated interface communication speed established</p> <p>0000₂ - No negotiated speed because the device is not present or communication is not established</p> <p>0001₂ - Generation 1 communication rate negotiated</p> <p>All other values are reserved.</p> <p>The default value after reset is 0000₂. After communications between the host controller and the device is established, the value will change to reset 0001₂.</p>

Table 135. SU PCI DPA SATA SStatus Register - SUPDSSSR (Sheet 2 of 2)

PCI IDE Mode BAR5 Offset = 000H,	DPA Mode BAR0 DPA Mode Offset Port 0 = 300H, Port 1 = 500H Port 2 = 700H, Port 3 = 900H	Attribute Legend: RV = Reserved RW = Read/Write PR = Preserved RC = Read Clear RS = Read/Set RO = Read Only NA = Not Accessible
Bit	Default	Description
03:00	0000 ₂	DET - Device Detection Mode: The DET value indicates the interface device detection state 0000 ₂ - No device detected and the PHY communication not established 0001 ₂ - Device presence detected but PHY communication not established 0011 ₂ - Device presence detected and PHY communication established 0100 ₂ - PHY offline as a result of the interface being disabled or running in BIST loopback All other values are reserved. The default value after reset is 0000 ₂ . After communications between the host controller and the device is established, the value will change to reset 0011 ₂ .

5.10.12.2 SU PCI DPA SATA SError Register - SUPDSSER

This SU PCI DPA SATA SError Register provides the supplemental interface error information to complement the error information available in the SU PCI DPA Error Register. The SU PCI DPA SATA SError Register provides all the detected errors accumulated since the last time its was cleared. This Register is broken into two 16-bit fields. Bits [31:16] contains the DIAG field and bit [15:0] contains the ERR field.

The ERR field contains error information for use by host software in determining the appropriate response to the error condition.

The DIAG field contains diagnostic error information for use by diagnostic software in validating correct operation or isolating failure modes.

Not all the SError bits are implemented on the GD31244 controller.

Refer to the *Serial ATA Specification*.

Table 136. SU PCI DPA SATA SError Register - SUPDSSER (Sheet 1 of 3)

Bit	Default	Description
31-26	000000 ₂	Reserved
25	0 ₂	DIAG_F - Invalid FIS Type: When set to one, this bit indicates that the FIS type field was not recognized. For example the FIS is invalid. This bit is cleared by writing a 1 to it.
24	0 ₂	DIAG_T - Reserved, not implemented.
23	0 ₂	DIAG_S - Reserved, not implemented.
22	0 ₂	DIAG_H - Handshake Error: When set to one, this bit indicates that one or more R_ERR handshake response was received in response to frame transmission. Such errors may be the result of a CRC error detected by the receiver. This bit is cleared by writing a 1 to it. This bit is reported as an interrupt on bit 3, 11, 19, and 27 of the SATA Interrupt Pending register for SATA ports 0, 1, 2, and 3 respectively. Refer to Table 116, "SU PCI DPA Interrupt Pending Register - SUPDIPR" on page 194.
21	0 ₂	DIAG_C - CRC Error: When set to one, this bit indicates that one or more CRC errors occurred. This bit is cleared by writing a 1 to it. This bit is reported as an interrupt on bit 6, 14, 22, and 30 of the SATA Interrupt Pending register for SATA ports 0, 1, 2, and 3 respectively. Refer to Table 116, "SU PCI DPA Interrupt Pending Register - SUPDIPR" on page 194.
20	0 ₂	DIAG_D - Disparity Error: When set to one, this bit indicates that incorrect disparity was detected one or more times since the last time this bit was cleared. This bit is cleared by writing a 1 to it.

PCI IDE Mode BAR5 Offset = 004H,	DPA Mode BAR0 Offset Port 0 = 304H, Port 1 = 504H Port 2 = 704H, Port 3 = 904H	Attribute Legend: RV = Reserved PR = Preserved RS = Read/Set	RW = Read/Write RC = Read Clear RO = Read Only NA = Not Accessible
----------------------------------	--	---	---

Table 136. SU PCI DPA SATA S Error Register - SUPDSSER (Sheet 2 of 3)

Bit	Default	Description
19	0 ₂	DIAG_B - not implemented.
18	0 ₂	DIAG_W - Comm Wake: When set to one, this bit indicates that a Comm Wake was detected by the PHY. This bit is cleared by writing a 1 to it. The default value after reset is 0 ₂ . After Comm Wake is detected, the value will change to 1 ₂ .
17	0 ₂	DIAG_I - Reserved, not implemented.
16	0 ₂	DIAG_N - PHYRDY Change State: When set to one this bit indicates that the PHYRDY signal changed state. State change means going from READY to NOT-READY or NOT-READY to READY. This bit shall remain cleared when the PHY was not detected as ready during the initialization process. When the PHY goes ready after initialization, this bit shall transition to 1. This bit is cleared by writing a 1 to it. This bit is reported as an interrupt on bit 0, 8, 16, and 24 of the SATA Interrupt Pending register for SATA ports 0, 1, 2, and 3 respectively. Refer to Table 116, "SU PCI DPA Interrupt Pending Register - SUPDIPR" on page 194. The default value after reset is 0 ₂ , for example the PHY will not be ready. When the PHY becomes ready (state change from not-ready to ready) as part of the initialization sequence, the value will change to 1 ₂ .
15-12	0000 ₂	Reserved.
11	0 ₂	ERR_E - Internal Error: This bit indicates that a FIFO error occurred due to a FIFO overrun or underrun condition. This bit is cleared by writing a 1 to it. This bit is reported as an interrupt on bit 2, 10, 18, and 26 of the SATA Interrupt Pending register for SATA ports 0, 1, 2, and 3 respectively. Refer to Table 116, "SU PCI DPA Interrupt Pending Register - SUPDIPR" on page 194.
10	0 ₂	ERR_P - Protocol Error: This bit when set indicates that a corrupted FIS was received. This bit may indicate that the FIS received was an invalid FIS type or that the received FIS was not properly structured. For example, incorrect length. This bit is cleared by writing a 1 to it. This bit is reported as an interrupt on bit 4, 12, 20, and 28 of the SATA Interrupt Pending register for SATA ports 0, 1, 2, and 3 respectively. Refer to Table 116, "SU PCI DPA Interrupt Pending Register - SUPDIPR" on page 194.
09	Varies with the signal level of the PHY receive path	ERR_C - Non-Recovered Communication: This is an asynchronous signal which reflects the signal level of the PHY receive path. When high, this bit indicates that there is no signal detected on the PHY receive path (RX). This may occur from a faulty interconnect, removal of a device, or the signal level is simply below the reference point.
08	0 ₂	ERR_T - Non-Recovered Transient Data Integrity Error: This bit indicates that either a CRC error, disparity error, or the receipt of an R_ERR primitive occurred in response to a Data FIS. This bit is cleared by writing a 1 to it. This bit is reported as an interrupt on bit 5, 13, 21, and 29 of the SATA Interrupt Pending register for SATA ports 0, 1, 2, and 3 respectively. Refer to Table 116, "SU PCI DPA Interrupt Pending Register - SUPDIPR" on page 194.
07:02	000000 ₂	Reserved

Table 136. SU PCI DPA SATA SError Register - SUPDSSER (Sheet 3 of 3)

Bit	Default	Description
01	0 ₂	<p>ERR_M - Recovered Communications Error:</p> <p>This bit indicates that the PHY went from NOT-READY to READY. This bit shall remain cleared when the PHY was not detected as ready during the initialization process. When the PHY goes ready after initialization, this bit shall transition to 1. This bit is cleared by writing a 1 to it. This bit is reported as an interrupt on bit 1, 9, 17, and 25 of the SATA Interrupt Pending register for SATA ports 0, 1, 2, and 3 respectively. Refer to Table 116, "SU PCI DPA Interrupt Pending Register - SUPDIPR" on page 194.</p> <p>The default value after reset is 0₂, for example the PHY will not be ready. When the PHY becomes ready as part of the initialization sequence, the value will change to 1₂.</p>
00	0 ₂	ERR_I - Reserved, not implemented.

5.10.12.3 SU PCI DPA SATA SControl Register - SUPDSSCR

The SU PCI DPA SATA SControl Register provides the interface by which software controls the SATA interface capabilities. Refer to the *Serial ATA Specification*. The GD31244 controller does not support Interface Power Management (IPM). Writing to the IPM field will have no effect.

Table 137. SU PCI DPA SATA SControl Register - SUPDSSCR

Bit	Default	Description
31:12	0000 0h	Reserved
11:08	0000 ₂	<p>IPM - The IPM field represents the enabled interface power management states that may be invoked:</p> <p>0000₂ - No interface power management state restrictions</p> <p>0001₂ - Transitions to the PARTIAL power management state disabled</p> <p>0010₂ - Transitions to the SLUMBER power management state disabled</p> <p>0011₂ - Transitions to the PARTIAL and SLUMBER power slumber management states disabled</p> <p>All other values are reserved.</p> <p>NOTE: Note that the GD31244 controller does not support Interface Power Management (IPM). Writing to the IPM field will have no effect.</p>
07:04	0000 ₂	<p>SPD - The SPD field represents the maximum allowed communication speed to negotiate</p> <p>0000₂ - No speed negotiation restrictions</p> <p>0001₂ - Limit speed negotiation to a rate not greater than Generation 1 communication rate</p> <p>All other values are reserved.</p>
03:00	Varies with external state of DPA_MODE# pin	<p>DET - The DET field controls the host adapter device detection and interface initialization.</p> <p>In PCI IDE mode, after PCI RESET is deasserted, the default value of this field will be 0000₂. This will implicitly initiate an initialization sequence.</p> <p>In DPA mode, after PCI RESET is deasserted, the default value of this field will be 0100₂. This will cause the PHY to stay offline, and will not cause an initialization sequence. To exit the offline state, a 0000₂ must be written. The transition from 0100₂ -> 0000₂ will initiate an initialization sequence.</p> <p>0000₂ - No device detection or initialization action requested. The DET field must be returned into this state from any other states. For example, when an initialization sequence (writing 0001₂) is to be initiated, the write sequence to the DET field need to be as follows: 0000₂->0001₂->0000₂.</p> <p>0001₂ - Perform interface communication initialization sequence (hard reset). The initialization sequence is triggered when the DET field transitions from 0000₂->0001₂. Once a value of 0001₂ is written to the DET field, a write of 0000₂ may immediately follow. When a second transition of 0000₂->0001₂ is detected while a previous initialization sequence is in progress, a new initialization sequence will be re-triggered.</p> <p>0100₂ - Disable the Serial ATA interface and put the PHY in offline mode.</p> <p>All other values are reserved.</p>

5.10.12.4 SU PCI DPA Set Device Bits Register - SUPDSDBR

The SU PCI DPA Set Device Bits Register is a 32-bit register. This register reflects the content of the Set Device Bit FIS reserved DWORD.

Table 138. SU PCI DPA Set Device Bits Register - SUPDSDBR

PCI IDE Mode Offset = 00CH,	DPA Mode BAR0 Offset Port 0 = 30CH, Port 1 = 50CH Port 2 = 70CH, Port 3 = 90CH	Attribute Legend: RV = Reserved PR = Preserved RS = Read/Set RW = Read/Write RC = Read Clear RO = Read Only NA = Not Accessible
Bit	Default	Description
31:00	0000_0000H	This is the SActive Register. The Serial ATA II Native Command Queueing specification defines this register as write read. Writing one to any bit will set the bait. The bits are cleared by the device set device bits FIS word 1 containing a 1 in that bit position. Writing a 0 to these bits by the host will not clear them.

5.10.12.5 SU PCI DPA PHY Feature Register - SUPDPFR

The SU PCI DPA PHY Feature Register is a 32-bit register. This register may be used to enable the full voltage swing on all the SATA ports, for extended applications such as backplanes or external cables.

Table 139. SU PCI DPA PHY Feature Register - SUPDPFR

Bit	Default	Description
31:20	000H	Reserved.
19:17	000 ₂	Reserved.
16	0 ₂	Reserved.
15	0 ₂	Reserved.
14	0 ₂	Full Voltage Swing - When HIGH, the transmitter output buffer for all of the ports will be in high swing mode for extended applications such as backplanes or external cables. When LOW, the transmitter output is compliant to Serial ATA specifications.
13	0 ₂	When HIGH, the serialized data in the transmitter is wrapped around to the input of the Clock Recovery Unit (CRU) in the receiver. When LOW, the RXxP/RXxN input is used by the receiver.
12	0 ₂	When HIGH, the cable equalizer within the receiver's input buffer is disabled. When LOW, the cable equalizer is enabled.
11:10	00 ₂	These two bits select the receiver's signal detect threshold level as follows: <ul style="list-style-type: none"> • 00 Nominal Setting: ~75 - 150 mV • 01 This reduces the nominal threshold by approximately ~25 mV • 10 This increases the nominal threshold by approximately ~25 mV • 11 This increases the nominal threshold by approximately ~50 mV.
09	0 ₂	Bit 8 must be set HIGH for Bit 9 to enable or disable the SERDES Tx buffers. With Bit 8 set HIGH and Bit 9 LOW, the Tx pins are enabled and driven from the core logic value. With Bit 8 set HIGH and Bit 9 set HIGH, the SERDES Tx buffer is disabled.
08	0 ₂	Bit 8 is the mux control that selects between Bit 9 or OOB logic to enable or disable the SERDES Tx pins. When HIGH, control is from Bit 9. When LOW, SERDES Tx buffer is enabled when the OOB sequence is active (while JTAG scan is not active).
07:00	00H	Reserved.

5.10.12.6 SU PCI DPA BIST FIS Control and Status Register - SUPDBFCSR

The SU PCI DPA BIST Control and Status Register is a 32-bit register. This register may be used to send a BIST Activate FIS to a far-end device. It may also be used to receive a BIST Activate FIS from a far-end device. A far-end device may be placed in one of three modes: Retimed loopback mode, AFE Analog loopback mode, and Transmit-Only mode. Refer to the *Serial ATA Specification*.

The BIST generator and data checker has 4 built-in patterns to be used in far-end retimed mode only. The first three modes are single patterns repeated indefinitely. The frame counter is not used for these patterns. The error will freeze at FFFFh if that many errors are detected. This prevents false interpretations due to a counter rollover. The BIST pattern 3 will send a counting pattern. The errors are not detected until three consecutive counts are detected. If this synchronization is never reached, then the error counter will contain 0. The frame counter will increment falsely if the pattern FFFFh is received. This test was designed to characterize a mostly working SATA physical connection. For such excessive error rates as would cause no three consecutive counting pattern Dwords to be recognized correctly, this feature should not be relied upon.

Table 140. SU PCI DPA BIST FIS Control and Status Register - SUPDBFCSR (Sheet 1 of 3)

Bit	Default	Description
31:30	00 ₂	BIST Pattern Select. These bits select the BIST pattern to generate for far-end loopback testing. The pattern is generated by setting bit 23 of this register. 00 ₂ - D21.5s 01 ₂ - D24.3s 10 ₂ - 3(D10.2s) and K28.5 11 ₂ - Counting pattern with smart comparison.
29:28	00 ₂	BIST Check Selection. Should be set to the same value as BIST pattern Select (bits [31:30]). Setting with a different value will cause mismatch.
27	0 ₂	Force a transmit side disparity error. Errors will be forced for the duration of this bit being set.
26	0 ₂	Force receive side disparity error. Errors will be forced for the duration of this bit being set.
25	0 ₂	Clear the BIST Errors/Frames registers. Writing a 1 to this bit will clear the BIST Errors register and BIST Frames register. This bit is always read as a 0.
24	0 ₂	BIST Check Enable. This bit enables the checker to compare the incoming loopback data stream selected by bits [29:28]. This bit must be set to 1 for proper BIST operation. When this bit is not set, the incoming data stream will not be verified.
23	0 ₂	BIST Pattern Enable. This bit enables the pattern generation selected by bits [31:30]. Note that sending a BIST Activate FIS does not automatically enables the generation of the BIST patterns. Write to 1 to enable and 0 to disable.
22	0 ₂	Invert Encoder outputs (effectively inverts tx +/-).
21	0 ₂	Invert Decoder inputs (effectively inverts rx +/-)

Table 140. SU PCI DPA BIST FIS Control and Status Register - SUPDBFCSR (Sheet 2 of 3)

Bit	Default	Description
20	0 ₂	Enable near end loop back confirm 1=loopback, 0=normal.
19	0 ₂	OOB Bypass. Setting this bit to a "1" will cause OOB processing to be bypassed.
18	0 ₂	Setting this bit to a "1" will force JTAG disable.
17	0 ₂	Setting this bit to a "1" will bypass transmit and receive scramblers, as well as no CONT primitive insertion.
16	0 ₂	Setting this bit high will cause the PHY to transmit a continuous stream of K28.5s. This is an independent bit that simply sends a stream of K28.5s over the serial bus. Does not require any other setup.
15	0 ₂	BIST Activate FIS has been received, and this device is in BIST mode.
14	0 ₂	BIST Activate FIS received with transmit-only bit set. When set, this bit indicates that the far-end device is requesting a transmit-only setup, and to transmit the DWORDs in SU PCI DPA Device BIST Data Low Register - SUPDDBDLR and SU PCI DPA Device BIST Data High Register - SUPDDBDHR . These are the DWORDs received as part of the BIST Activate FIS.
13	0 ₂	BIST Activate FIS received with align bypass bit set. This bit must be qualified when bit 14 is set.
12	0 ₂	BIST Activate FIS received with scrambling bypass bit set. This bit must be qualified when bit 14 is set.
11	0 ₂	BIST Activate FIS received with retimed bit set. When set, this bit indicates that the far-end device is requesting a retimed loopback setup path.
10	0 ₂	BIST Activate FIS received with primitive bit set. This bit must be qualified when bit 14 is set.
09	0 ₂	BIST Activate FIS received with AFE loopback bit set. When set, this bit indicates that the far-end device is requesting an AFE Analog loopback each setup.
08	0 ₂	Setting this bit high will cause the PHY to transmit a continuous stream of K28.5s. This is an independent bit that sends a stream of K28.7s over the serial bus. Does not require any other setup.
07	0 ₂	Send BIST Activate FIS. This bit is used to initiate the transfer of a BIST Activate FIS to the far-end device. Bits [6:1] must be setup accordingly before setting this bit.
06	0 ₂	Send BIST Activate FIS with transmit-only bit set. This bit is used to command the far-end device to place itself in a transmit-only mode, and to transmit data patterns indicated in the BIST Activate FIS (Data DWORDs) it received from the sender. Bits 5, 4 and 2 may optionally be used when requesting this mode.
05	0 ₂	Send BIST Activate FIS with align bypass bit set. This bit may be used in conjunction with bit 6.
04	0 ₂	Send BIST Activate FIS with scrambling bypass bit set. This bit may be used in conjunction with bit 6.
03	0 ₂	Send BIST Activate FIS with retimed bit set. This bit is used to command the far-end device to setup a retimed loopback path.
02	0 ₂	Send BIST Activate FIS with primitive bit set. This bit may be used in conjunction with bit 6.
01	0 ₂	Send BIST Activate FIS with AFE loopback bit set. This bit is used to command the far-end device to setup an AFE Analog loopback path.

Table 140. SU PCI DPA BIST FIS Control and Status Register - SUPDBFCSR (Sheet 3 of 3)

PCI IDE Mode Offset = 044H,	DPA Mode Offset Port 0 = 344H, Port 1 = 544H Port 2 = 744H, Port 3 = 944H	Attribute Legend: RV = Reserved RW = Read/Write PR = Preserved RC = Read Clear RS = Read/Set RO = Read Only NA = Not Accessible
Bit	Default	Description
00	0 ₂	Initiate a near end transmit-only based upon bits 6, 5, 4, and 2 and BIST DWORDs - SU PCI DPA Host BIST Data Low Register - SUPDHBDLR and SU PCI DPA Host BIST Data High Register - SUPDHBDDR.

To command the receiver into a Far-End Retimed loopback mode, bit 3 of the BIST FIS Control and Status Register must be set. To command the receiver into the Far-End Analog loopback mode, bit 1 must be set. After the appropriate bit(s) are set in bits [6:1], the BIST Activate FIS may be sent to the receiving device by setting bit 7. The GD31244 controller also provides the following registers for monitoring the BIST tests:

- BIST Error register
- BIST Frame register

The BIST Errors register tracks the number of errors detected. The BIST Frame register tracks when the 16-bit counting pattern is selected and the number of BIST frames encountered. A frame is defined as one 6-bit counting pattern sequence. The following steps provide an example of how to set up and initiate a loopback test:

1. Set bit 25 to reset the BIST Errors and BIST Frames registers.
2. Set bits [31:30] to select one of the BIST patterns.
3. Set bits [29:28] with the same value as bits [31:30]. These bits define the pattern used for checking the data stream.
4. Set bit 1 to select AFE or bit 3 to select Retimed loopback.
5. Set bit 24 to enable the pattern generator.
6. Set bit 23 to enable the pattern checker.

Note: To conclude the loopback test, the far-end device must be reset using a COMRESET/COMINIT sequence.

5.10.12.7 SU PCI DPA BIST Errors Register - SUPDBER

The SU PCI DPA BIST Errors Register is a 32-bit register. This register is used during far-end loopback testing. This register is updated/incremented each time an error is detected.

Table 141. SU PCI DPA BIST Errors Register - SUPDBER

PCI IDE Mode Offset = 048H,	DPA Mode Offset Port 0 = 348H, Port 1 = 548H Port 2 = 748H, Port 3 = 948H	Attribute Legend: RV = Reserved RC = Read Clear PR = Preserved RO = Read Only RS = Read/Set NA = Not Accessible
Bit	Default	Description
31:16	0000H	Reserved
15:00	0000H	BIST Errors. This register contains the number of errors that occurred since the last time the BIST FIS Control and Status register bit 25 was set. This register may count up to FFFFH - only 16-bit is implemented. This register will not rollover after a count of FFFFH is reached. For example, the counter will stop when a value of FFFFH is reached.

5.10.12.8 SU PCI DPA BIST Frames Register - SUPDBFR

The SU PCI DPA BIST Frames Register is a 32-bit register. This register is used during far-end loopback testing, and is only used for the counting pattern. Refer to bits [31:30] of the [SU PCI DPA BIST FIS Control and Status Register - SUPDBFCSR](#) for pattern selection.

Table 142. SU PCI DPA BIST Frames Register - SUPDBFR

PCI IDE Mode BAR5 Offset = 04CH,	DPA Mode Offset Port 0 = 34CH, Port 1 = 54CH Port 2 = 74CH, Port 3 = 94CH	Attribute Legend: RV = Reserved RW = Read/Write PR = Preserved RC = Read Clear RS = Read/Set RO = Read Only NA = Not Accessible
Bit	Default	Description
31:00	0000_0000H	BIST Frames. This register contains the number of BIST Frames that occurred since the last time the BIST FIS Control and Status register bit 25 was set. A BIST frame is 65536 DWORDs. Refer to Section 5.5, "Serial ATA BIST" on page 79 for a description of a BIST Frame.

5.10.12.9 SU PCI DPA Host BIST Data Low Register - SUPDHBDLR

The SU PCI DPA Host BIST Data Low Register is the first 32-bit parameter of the SATA BIST Activate Host-to-Device FIS. Refer to the *Serial ATA Specification*.

Table 143. SU PCI DPA Host BIST Data Low Register - SUPDHBDLR

PCI IDE Mode Offset = 050H,	DPA Mode Offset Port 0 = 350H, Port 1 = 550H Port 2 = 750H, Port 3 = 950H	Attribute Legend: RV = Reserved PR = Preserved RS = Read/Set RW = Read/Write RC = Read Clear RO = Read Only NA = Not Accessible
Bit	Default	Description
31:00	0000_0000H	This register contains the data transmitted as BIST FIS DWORD 1.

5.10.12.10 SU PCI DPA Host BIST Data High Register - SUPDHBDR

The SU PCI DPA Host BIST Data High Register is the second 32-bit parameter of the SATA Bist Activate Host-to-Device FIS. Refer to the *Serial ATA Specification*.

Table 144. SU PCI DPA Host BIST Data High Register - SUPDHBDR

PCI IDE Mode Offset = 054H,	DPA Mode Offset Port 0 = 354H, Port 1 = 554H Port 2 = 754H, Port 3 = 954H	Attribute Legend: RW = Read/Write RV = Reserved PR = Preserved RS = Read/Set RC = Read Clear RO = Read Only NA = Not Accessible
Bit	Default	Description
31:00	0000_0000H	This register contains the data transmitted as BIST FIS DWORD 2.

5.10.12.11 SU PCI DPA Device BIST Data Low Register - SUPDDBDLR

The SU PCI DPA Device BIST Data Low Register is the first 32-bit parameter of the SATA Bist Activate Device-to-Host FIS. Refer to the *Serial ATA Specification*.

Table 145. SU PCI DPA Device BIST Data Low Register - SUPDDBDLR

PCI IDE Mode Offset = 058H,	DPA Mode Offset Port 0 = 358H, Port 1 = 558H Port 2 = 758H, Port 3 = 958H	Attribute Legend: RV = Reserved RC = Read Clear PR = Preserved RO = Read Only RS = Read/Set NA = Not Accessible
Bit	Default	Description
31:00	0000_0000H	This register contains the data transmitted as BIST FIS DWORD 1.

5.10.12.12 SU PCI DPA Device BIST Data High Register - SUPDDBDHR

The SU PCI DPA Device BIST Data High Register is the second 32-bit parameter of the SATA Bist Activate Device-to-Host FIS. Refer to the *Serial ATA Specification*.

Table 146. SU PCI DPA Device BIST Data High Register - SUPDDBDHR

PCI IDE Mode Offset = 05CH,	DPA Mode Offset Port 0 = 35CH, Port 1 = 55CH Port 2 = 75CH, Port 3 = 95CH	Attribute Legend: RV = Reserved RW = Read/Write PR = Preserved RC = Read Clear RS = Read/Set RO = Read Only NA = Not Accessible
Bit	Default	Description
31:00	0000_0000H	This register contains the data transmitted as BIST FIS DWORD 2.

5.10.12.13 SU PCI DPA Queuing Table Base Address Register Low - SUPDQTBARL

This register contains the lower values added to the DMA buffer identifier to determine the base address of the PRD.

Table 147. SU PCI DPA Device BIST Data High Register - SUPDDBDHR

PCI IDE Mode Offset = 060H,	DPA Mode Offset Port 0 = 360H, Port 1 = 560CH Port 2 = 760H, Port 3 = 960H	Attribute Legend: RV = Reserved PR = Preserved RS = Read/Set RW = Read/Write RC = Read Clear RO = Read Only NA = Not Accessible
Bit	Default	Description
31:00	0000_0000H	Value used by the DMA engine to add to the DMA Buffer identifier to get the base address of the PRD, bits 31:0.

5.10.12.14 SU PCI DPA Queuing Table Base Address Register High - SUPDQTBARH

This register contains the lower values added to the DMA buffer identifier to determine the base address of the PRD.

Table 148. SU PCI DPA Device BIST Data High Register - SUPDDBDHR

PCI IDE Mode Offset = 064H,	DPA Mode Offset Port 0 = 364H, Port 1 = 564CH Port 2 = 764H, Port 3 = 964H	Attribute Legend: RV = Reserved PR = Preserved RS = Read/Set RW = Read/Write RC = Read Clear RO = Read Only NA = Not Accessible
Bit	Default	Description
31:00	0000_0000H	Value used by the DMA engine to add to the DMA Buffer identifier to get the base address of the PRD, bits 63:32.

5.10.12.15 SU PCI DPA DMA Setup FIS Control and Status Register - SUPDDSFCSR

The SU PCI DPA DMA Setup FIS Control and Status Register is a 32-bit register. This register is used to initiate a DMA Setup FIS. This register also contains the status of a received DMA Setup FIS.

Table 149. SU PCI DPA DMA Setup FIS Control and Status Register - SUPDDSFCSR

Bit	Default	Description
31	0 ₂	Direction bit. This bit affects first party setup FIS word 0 direction bit. 0 = Receive (receiver to transmitter) 1 = Send (transmitter to receiver)
30	0 ₂	Interrupt – received first party setup FIS with the I bit set.
29	0 ₂	Reserved.
28	0 ₂	Start DMA Setup FIS Bit. Start transmission of DMA setup FIS. A one shot and will always read back a 0.
27	0 ₂	Enable first party DMA auto processing for command queuing. Enables DMA controller to automatically process DMA Setup FIS data in order to choose a DMA descriptor table for a queued command.
26	0 ₂	Reserved.
25	0 ₂	Reserved.
24	0 ₂	Abort TSM – Setting this bit will stop the transport/link state machines. This bit is one-shot, and will be cleared after the TSM goes idle.
23	0 ₂	The last FIS sent received an RNAK primitive as response.
22	0 ₂	Reserved.
21:16	000000 ₂	Reserved.
15	0 ₂	Reserved.
14	0 ₂	Reserved.
13	0 ₂	Reserved.
12	0 ₂	Reserved.
11	0 ₂	Reserved.
10	0 ₂	Reserved.
9	0 ₂	Reserved.
8	0 ₂	Reserved.
07:00	00H	Reserved.

5.10.12.16 SU PCI DPA Host DMA Buffer Identifier Low Register - SUPDHDBILR

The SU PCI DPA Host DMA Buffer Identifier Low Register is the first DWORD parameter of the SATA DMA Setup Host-to-Device FIS. Refer to the *Serial ATA Specification*.

Table 150. SU PCI DPA Host DMA Buffer Identifier Low Register - SUPDHDBILR

PCI IDE Mode Offset = 06CH,	DPA Mode Offset Port 0 = 36CH, Port 1 = 56CH Port 2 = 76CH, Port 3 = 96CH	Attribute Legend: RV = Reserved RW = Read/Write PR = Preserved RC = Read Clear RS = Read/Set RO = Read Only NA = Not Accessible
Bit	Default	Description
31:00	0000_0000H	Buffer Identifier Low - This is the lower DWORD of a 64-bit buffer identifier, which may be used to identify a DMA buffer region in host memory.

5.10.12.17 SU PCI DPA Host DMA Buffer Identifier High Register - SUPDHDBIHR

The SU PCI DPA Host DMA Buffer Identifier High Register is the second DWORD parameter of the SATA DMA Setup Host-to-Device FIS. Refer to the *Serial ATA Specification*.

Table 151. SU PCI DPA Host DMA Buffer Identifier High Register - SUPDHDBIHR

PCI IDE Mode Offset = 070H,	DPA Mode Offset Port 0 = 370H, Port 1 = 570H Port 2 = 770H, Port 3 = 970H	Attribute Legend: RV = Reserved PR = Preserved RS = Read/Set RW = Read/Write RC = Read Clear RO = Read Only NA = Not Accessible
Bit	Default	Description
31:00	0000_0000H	Buffer Identifier High - This is the upper DWORD of a 64-bit buffer identifier, which may be used to identify a DMA buffer region in host memory.

5.10.12.18 SU PCI DPA Host Reserved DWORD Register 0 - SUPDHRDR0

The SU PCI DPA Host Reserved Register 0 is the third DWORD parameter of the SATA DMA Setup Host-to-Device FIS. Refer to the *Serial ATA Specification*.

Table 152. SU PCI DPA Host Reserved DWORD Register 0 - SUPDHRDR 0

PCI IDE Mode Offset = 074H,	DPA Mode Offset Port 0 = 374H, Port 1 = 574H Port 2 = 774H, Port 3 = 974H	Attribute Legend: RV = Reserved PR = Preserved RS = Read/Set RW = Read/Write RC = Read Clear RO = Read Only NA = Not Accessible
Bit	Default	Description
31:00	0000_0000H	Reserved DWORD in the SATA DMA Setup Host-to-Device FIS.

5.10.12.19 SU PCI DPA Host DMA Buffer Offset Register - SUPDHDBOR

The SU PCI DPA Host DMA Buffer Offset Register is the fourth DWORD parameter of the SATA DMA Setup Host-to-Device FIS. Refer to the *Serial ATA Specification*.

Table 153. SU PCI DPA Host DMA Buffer Offset Register - SUPDHDBOR

PCI IDE Mode Offset = 078H,	DPA Mode Offset Port 0 = 378H, Port 1 = 578H Port 2 = 778H, Port 3 = 978H	Attribute Legend: RV = Reserved PR = Preserved RS = Read/Set RW = Read/Write RC = Read Clear RO = Read Only NA = Not Accessible
Bit	Default	Description
31:00	0000_0000H	Buffer Offset - This is the byte offset into the DMA buffer region.

5.10.12.20 SU PCI DPA Host DMA Transfer Count Register - SUPDHDTCR

The SU PCI DPA Host DMA Transfer Count Register is the fifth DWORD parameter of the SATA DMA Setup Host-to-Device FIS. Refer to the *Serial ATA Specification*.

Table 154. SU PCI DPA Host DMA Transfer Count Register - SUPDHDTCR

PCI IDE Mode Offset = 07CH,	DPA Mode Offset Port 0 = 37CH, Port 1 = 57CH Port 2 = 77CH, Port 3 = 97CH	Attribute Legend: RV = Reserved RW = Read/Write PR = Preserved RC = Read Clear RS = Read/Set RO = Read Only NA = Not Accessible
Bit	Default	Description
31:00	0000_0000H	Transfer Count - This is the number of bytes that will be read or written by the device.

5.10.12.21 SU PCI DPA Host Reserved DWORD Register 1- SUPDHRDR1

The SU PCI DPA Host Reserved Register 1 is the sixth DWORD parameter of the SATA DMA Setup Host-to-Device FIS. Refer to the *Serial ATA Specification*.

Table 155. SU PCI DPA Host Reserved DWORD Register 1- SUPDHRDR 1

PCI IDE Mode Offset = 080H,	DPA Mode Offset Port 0 = 380H, Port 1 = 580H Port 2 = 780H, Port 3 = 980H	Attribute Legend: RV = Reserved RC = Read Clear PR = Preserved RO = Read Only RS = Read/Set NA = Not Accessible
Bit	Default	Description
31:00	0000_0000H	Reserved DWORD in the SATA DMA Setup Host-to-Device FIS.

5.10.12.22 SU PCI DPA Device DMA Buffer Identifier Low Register - SUPDDDBILR

The SU PCI DPA Device DMA Buffer Identifier Low Register is the first DWORD parameter of the SATA DMA Setup Device-to-Host FIS. Refer to the *Serial ATA Specification*.

Table 156. SU PCI DPA Device DMA Buffer Identifier Low Register - SUPDDDBILR

PCI IDE Mode Offset = 084H,	DPA Mode Offset Port 0 = 384H, Port 1 = 584H Port 2 = 784H, Port 3 = 984H	Attribute Legend: RV = Reserved RW = Read/Write PR = Preserved RC = Read Clear RS = Read/Set RO = Read Only NA = Not Accessible
Bit	Default	Description
31:00	0000_0000H	Buffer Identifier Low - This is the lower DWORD of a 64-bit buffer identifier, which may be used to identify a DMA buffer region of the First Party Setup FIS received from a device.

5.10.12.23 SU PCI DPA Device DMA Buffer Identifier High Register - SUPDDDBIHR

The SU PCI DPA Device DMA Buffer Identifier High Register is the second DWORD parameter of the SATA DMA Setup Device-to-Host FIS. Refer to the *Serial ATA Specification*.

Table 157. SU PCI DPA Device DMA Buffer Identifier High Register - SUPDDDBIHR

PCI IDE Mode Offset = 088H,	DPA Mode Offset Port 0 = 388H, Port 1 = 588H Port 2 = 788H, Port 3 = 988H	Attribute Legend: RV = Reserved PR = Preserved RS = Read/Set	RW = Read/Write RC = Read Clear RO = Read Only NA = Not Accessible
Bit	Default	Description	
31:00	0000_0000H	Buffer Identifier High - This is the upper 32 bits of the DMA Buffer Identifier field of the First Party Setup FIS received from a device.	

5.10.12.24 SU PCI DPA Host Reserved DWORD Register 0 - SUPDHRDR0

The SU PCI DPA Received Host Reserved Register 0 is the third DWORD parameter of the SATA DMA Setup Host-to-Device FIS. Refer to the *Serial ATA Specification*.

Table 158. SU PCI DPA Device Reserved DWORD Register 0 - SUPDDRDR0

PCI IDE Mode Offset = 08CH,	DPA Mode Offset Port 0 = 38CH, Port 1 = 58CH Port 2 = 78CH, Port 3 = 98CH	Attribute Legend: RV = Reserved PR = Preserved RS = Read/Set RW = Read/Write RC = Read Clear RO = Read Only NA = Not Accessible
Bit	Default	Description
31:00	0000_0000H	Reserved DWORD in the SATA DMA Setup Device-to-Host FIS.

5.10.12.25 SU PCI DPA Device DMA Buffer Offset Register - SUPDDDBOR

The SU PCI DPA Device DMA Buffer Offset Register is the fourth DWORD parameter of the SATA DMA Setup Device-to-Host FIS. Refer to the *Serial ATA Specification*.

Table 159. SU PCI DPA Device DMA Buffer Offset Register - SUPDDDBOR

PCI IDE Mode Offset = 090H,	DPA Mode Offset Port 0 = 390H, Port 1 = 590H Port 2 = 790H, Port 3 = 990H	Attribute Legend: RV = Reserved RC = Read Clear PR = Preserved RO = Read Only RS = Read/Set NA = Not Accessible
Bit	Default	Description
31:00	0000_0000H	Buffer Offset - The buffer offset field of the First Party Setup FIS.

5.10.12.26 SU PCI DPA Device DMA Transfer Count Register - SUPDDTCCR

The SU PCI DPA Device DMA Transfer Count Register is the fifth DWORD parameter of the SATA DMA Setup Device-to-Host FIS. Refer to the *Serial ATA Specification*.

Table 160. SU PCI DPA Device DMA Transfer Count Register - SUPDDTCCR

PCI IDE Mode Offset = 094H,	DPA Mode Offset Port 0 = 394H, Port 1 = 594H Port 2 = 794H, Port 3 = 994H	Attribute Legend: RV = Reserved PR = Preserved RS = Read/Set RW = Read/Write RC = Read Clear RO = Read Only NA = Not Accessible
Bit	Default	Description
31:00	0000_0000H	Transfer Count - The transfer Count field of the First Party Setup FIS.

5.10.12.27 SU PCI DPA Device Reserved DWORD Register 1 - SUPDDRDR1

The SU PCI DPA Device Reserved Register 1 is the sixth DWORD parameter of the SATA DMA Setup Host-to-Device FIS. Refer to the *Serial ATA Specification*.

Table 161. SU PCI DPA Device Reserved DWORD Register 1 - SUPDDRDR1

PCI IDE Mode Offset = 098H,	DPA Mode Offset Port 0 = 398H, Port 1 = 598H Port 2 = 798H, Port 3 = 998H	Attribute Legend: RV = Reserved RC = Read Clear PR = Preserved RO = Read Only RS = Read/Set NA = Not Accessible
Bit	Default	Description
31:00	0000_0000H	Reserved DWORD in the SATA DMA Setup Device-to-Host FIS.



This Page Left Intentionally Blank