

# Accutek Microcircuit Corporation

## AK632256AW 262,144 x 32 Bit CMOS/BiCMOS Static Random Access Memory

### DESCRIPTION

The Accutek AK632256AW SRAM Module consists of eight fast high performance SRAMs mounted on a low profile, 64 pin SIM PCB. The module utilizes four 28 pin 256K x 4 SRAMs in 300 mil SOJ packages and four decoupling capacitor chips mounted on each side of a printed circuit board.

The SRAMs used have common I/O functions and single output enable functions. Also, four separate chip select ( $\overline{CE}$ ) connections are used to independently enable the four bytes. The modules can be supplied in a variety of access time values from 12 nSEC to 45 nSEC in CMOS or BiCMOS technology.

The Accutek module is designed to have a maximum seated height of 0.600 inch to provide for the lowest height off the board. By off-set-mounting the back surface SRAMs the module can be mounted in either angled or straight-up SIM sockets. The modules conform to JEDEC standard sizes and pin-out configurations. Using two pins for module memory density identification, PD<sub>0</sub> and PD<sub>1</sub>, minimizes interchangeability and design considerations when changing from one module size to another in customer applications.

### FEATURES

- 262,144 x 32 bit organization
- JEDEC Standardized 64 pin SIM format
- Available with solder or gold leads
- Presence Detect PD<sub>0</sub> and PD<sub>1</sub> for identifying module density
- Common I/O, single  $\overline{OE}$  functions with four separate chip selects ( $\overline{CE}$ )
- Low height, 0.600 inch maximum seated height
- Single 5 volt power supply - AK632256AW
- Single 3.3 volt power supply - AK632256AW/3.3

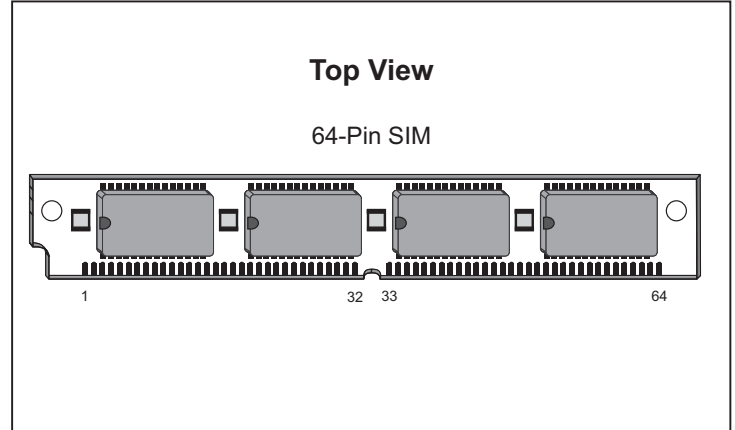

- Downward compatible with 128K x 32 (AK632128), 64K x 32 (AK63264) and 32K x 32 (AK63232)
- Upward compatible with 512K x 32 (AK632512) and 1 Meg x 32 (AK6321024)
- Fast access times range from 12 nSEC BiCMOS to 45 nSEC CMOS
- TTL-compatible inputs and outputs
- Operating temperature range in free air, 0°C to 70°C

### ELECTRICAL SPECIFICATIONS

Timing diagrams and basic electrical characteristics are those of the standard 256K x 4 SRAMs used to construct these modules. Accutek's module design allows the flexibility of selecting industry-compatible 256K x 4 SRAMs from several semiconductor manufacturers.

### PIN NOMENCLATURE

A <sub>0</sub> - A <sub>17</sub>	Address Inputs
$\overline{CE}_1$ - $\overline{CE}_4$	Chip Enable
DQ <sub>1</sub> - DQ <sub>32</sub>	Data In/Data Out
$\overline{OE}$	Output Enable
PD <sub>0</sub> - PD <sub>1</sub>	Presence Detect
V <sub>cc</sub>	Power Supply
V <sub>ss</sub>	Ground
$\overline{WE}$	Write Enable

### PIN ASSIGNMENT

PIN #	SYMBOL	PIN #	SYMBOL	PIN #	SYMBOL	PIN #	SYMBOL
1	V <sub>ss</sub>	17	A <sub>2</sub>	33	$\overline{CE}_4$	49	A <sub>4</sub>
2	PD <sub>0</sub>	18	A <sub>9</sub>	34	$\overline{CE}_3$	50	A <sub>11</sub>
3	PD <sub>1</sub>	19	DQ <sub>13</sub>	35	A <sub>17</sub>	51	A <sub>5</sub>
4	DQ <sub>1</sub>	20	DQ <sub>5</sub>	36	A <sub>16</sub>	52	A <sub>12</sub>
5	DQ <sub>9</sub>	21	DQ <sub>14</sub>	37	$\overline{OE}$	53	V <sub>cc</sub>
6	DQ <sub>2</sub>	22	DQ <sub>6</sub>	38	V <sub>ss</sub>	54	A <sub>13</sub>
7	DQ <sub>10</sub>	23	DQ <sub>15</sub>	39	DQ <sub>25</sub>	55	A <sub>6</sub>
8	DQ <sub>3</sub>	24	DQ <sub>7</sub>	40	DQ <sub>17</sub>	56	DQ <sub>21</sub>
9	DQ <sub>11</sub>	25	DQ <sub>16</sub>	41	DQ <sub>26</sub>	57	DQ <sub>29</sub>
10	DQ <sub>4</sub>	26	DQ <sub>8</sub>	42	DQ <sub>18</sub>	58	DQ <sub>22</sub>
11	DQ <sub>12</sub>	27	V <sub>ss</sub>	43	DQ <sub>27</sub>	59	DQ <sub>30</sub>
12	V <sub>cc</sub>	28	$\overline{WE}$	44	DQ <sub>19</sub>	60	DQ <sub>23</sub>
13	A <sub>0</sub>	29	A <sub>15</sub>	45	DQ <sub>28</sub>	61	DQ <sub>31</sub>
14	A <sub>7</sub>	30	A <sub>14</sub>	46	DQ <sub>20</sub>	62	DQ <sub>24</sub>
15	A <sub>1</sub>	31	$\overline{CE}_2$	47	A <sub>3</sub>	63	DQ <sub>32</sub>
16	A <sub>8</sub>	32	$\overline{CE}_1$	48	A <sub>10</sub>	64	V <sub>ss</sub>

PD<sub>0</sub> = V<sub>ss</sub>  
PD<sub>1</sub> = V<sub>ss</sub>

### FUNCTIONAL DIAGRAM

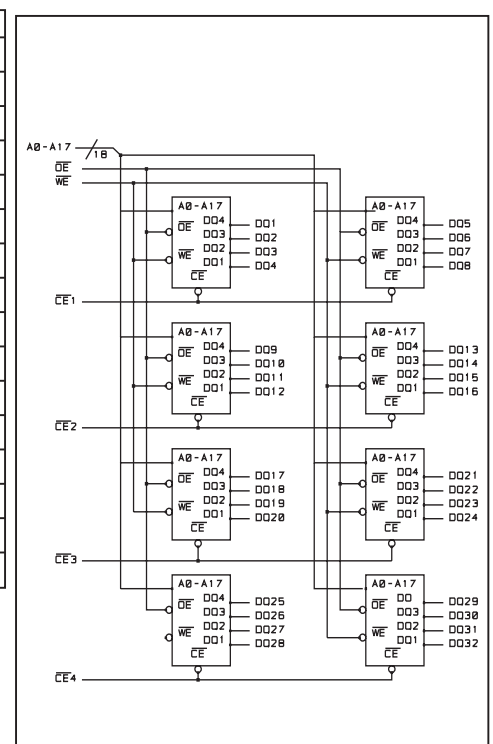

### MODULE OPTIONS

Leadless SIM, Solder Leads: AK632256AW

Leadless SIM, Gold Leads: AK632256AWG

## ORDERING INFORMATION

### PART NUMBER CODING INTERPRETATION

Position	1	2	3	4	5	6	7	8
<b>1 Product</b>								
	<b>AK = Accuthek Memory</b>							
<b>2 Type</b>								
	4 = Dynamic RAM							
	5 = CMOS Dynamic RAM							
	6 = Static RAM							
<b>3 Organization/Word Width</b>								
	1 = by 1		16 = by 16					
	4 = by 4		32 = by 32					
	8 = by 8		36 = by 36					
	9 = by 9							
<b>4 Size/Bits Depth</b>								
	64 = 64K		4096 = 4 MEG					
	256 = 256K		8192 = 8 MEG					
	1024 = 1 MEG		16384 = 16 MEG					
<b>5 Package Type</b>								
	G = Single In-Line Package (SIP)							
	S = Single In-Line Module (SIM)							
	D = Dual In-Line Package (DIP)							
	W = .050 inch Pitch Edge Connect							
	Z = Zig-Zag In-Line Package (ZIP)							
<b>6 Special Designation</b>								
	P = Page Mode							
	N = Nibble Mode							
	K = Static Column Mode							
	W = Write Per Bit Mode							
	V = Video Ram							
<b>7 Separator</b>								
	- = Commercial 0°C to +70°C							
	M = Military Equivalent Screened (-55°C to +125°C)							
	I = Industrial Temperature Tested (-45°C to +85°C)							
	X = Burned In							
<b>8 Speed (first two significant digits)</b>								
	DRAMS				SRAMS			
	50 = 50 nS		8 = 8 nS					
	60 = 60 nS		10 = 10 nS					
	70 = 70 nS		12 = 12 nS					
	80 = 80 nS		15 = 15 nS					

The numbers and coding on this page do not include all variations available but are show as examples of the most widely used variations. Contact Accuthek if other information is required.

### EXAMPLES:

#### AK632256AWG-12

256K x 32, 12 nSEC SRAM Module, SIM Configuration with Gold Leads

#### AK632256AW-15

256K x 32, 15nSEC SRAM Module, SIM Configuration with Solder Leads

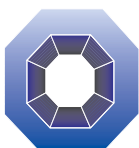

**ACCUTEK MICROCIRCUIT CORPORATION**  
 BUSINESS CENTER at NEWBURYPORT  
 2 NEW PASTURE ROAD, SUITE 1  
 NEWBURYPORT, MA 01950-4054  
 VOICE: 978-465-6200 FAX: 978-462-3396  
 Email: sales@accuthekmicro.com  
 Internet: www.accuthekmicro.com

## MECHANICAL DIMENSIONS

Inches

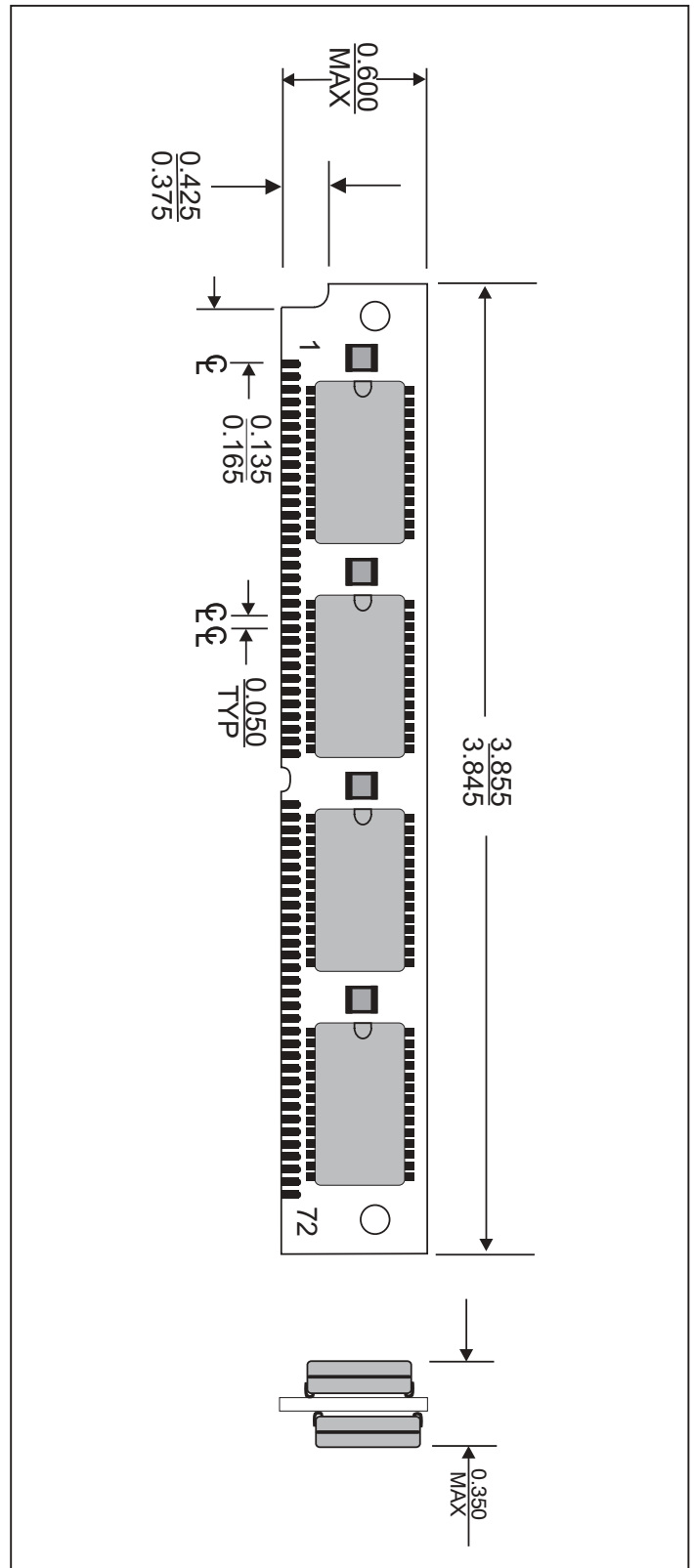

Accuthek reserves the right to make changes in specifications at any time and without notice. Accuthek does not assume any responsibility for the use of any circuitry described; no circuit patent licenses are implied. Preliminary data sheets contain minimum and maximum limits based upon design objectives, which are subject to change upon full characterization over the specific operating conditions.