

OPTION G

NOTES:

- TO BE USED WITH (22) AWG. STRANDED WIRE WITH (1.35)/.053 DIA. MAX. INSULATION.
- SEE CHART FOR CIRCUIT SIZES.
- STANDARD PACKAGING PER PK-70873-0001. OPTIONAL PACKAGING MAY BE AVAILABLE, REQUEST DWG. PK-70400
- PARTS STACKABLE END TO END ON (2.54)/.100 CENTERS.
- REFER TO PRODUCT SPECIFICATION: PS-70400.
- SEE DWG. SDA-70400-**** (SHT. 5) FOR OPTIONAL HOUSING DETAILS.
- 4 CIRCUIT SHOWN. 4 - 25 CKT'S. HAVE (2) RIBS.
- TO MATE WITH MOLEX PART NO'S.: A-70373-****, A-70375-****, A-70389-****, A-70391-****, 70107-****, 70018-****, A-70543-****, A-70553-****, A-70541-****, A-70551-****, A-70545-****, A-70555-****.
- 2 CIRCUIT ASSEMBLIES SUPPLIED AS GROUPED PAIRS.

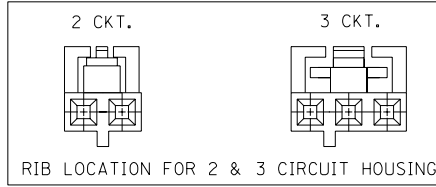

SECTION C-C

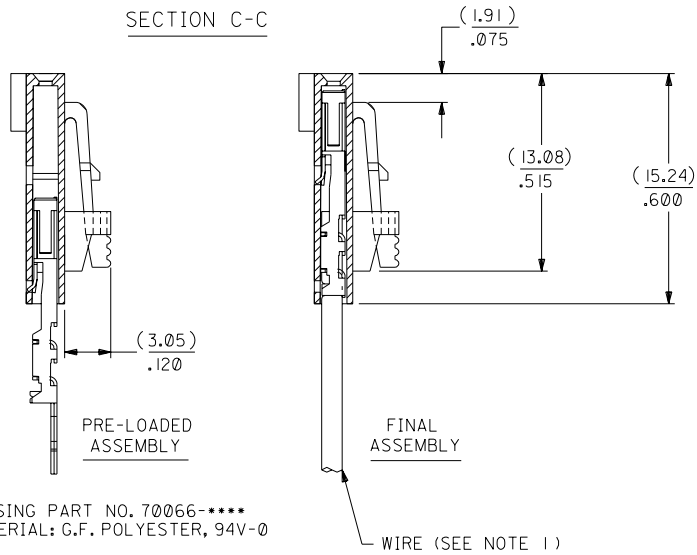

CIRCUIT NO. 1
SLOT OR ARROW

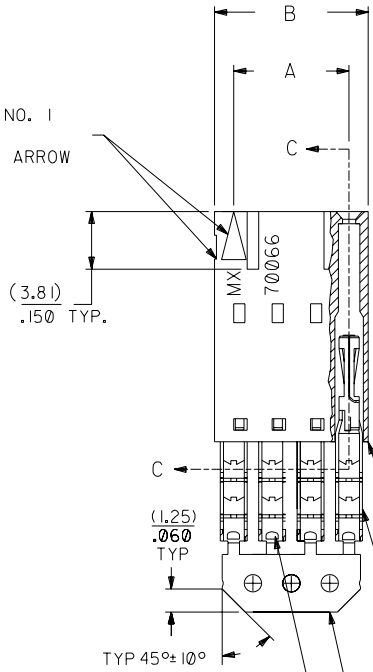
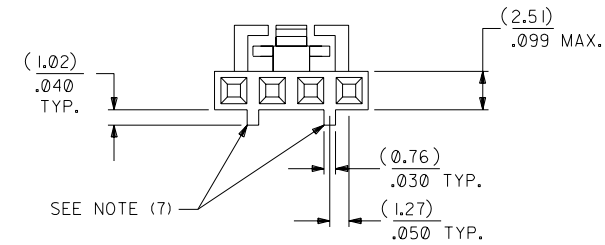

HOUSING PART NO. 70066-****
MATERIAL: G.F. POLYESTER, 94V-0

TERMINAL PART NO. 70028-****
MATERIAL: PHOSPHOR BRONZE
PLATING PER ES-88-***

30 GOLD - .000030 MIN. GOLD IN SELECT AREA WITH .000075 MIN. TIN IN SELECT AREA OVER .000050 MIN. NICKEL OVER-ALL.

*THE PRIMARY SHIPPING CARTON WILL BE LABELED "COMPLIANT TO ROHS DIRECTIVE 2002/95/EC AND ELV ANNEX II OF DIRECTIVE 2000/53/EC". CARTONS WITHOUT THIS LABEL MAY CONTAIN PRODUCT WITH LEAD.

| I.D. SLOT CODE TO WIRE GAUGE CHART | |
|------------------------------------|------------|
| I.D. SLOT CODE | WIRE GAUGE |
| D | 22 AWG. |

| PLATING CODE (STRIPE ON CARRIER STRIP) | |
|----------------------------------------|-------|
| PLATING | COLOR |
| 30 GOLD | RED |

| CKT. SIZE | A | B | EDP. NO. | ENG. NO. |
|-----------|--------------------|--------------------|------------|--------------|
| 2 | (2.54) .100 | (5.05) .199 | 14-56-8022 | A-70400-3490 |
| 3 | (5.08) .200 | (7.59) .299 | 14-56-8032 | A-70400-3491 |
| 4 | (7.62) .300 | (10.13) .399 | 14-56-8042 | A-70400-3492 |
| 5 | (10.16) .400 | (12.67) .499 | 14-56-8052 | A-70400-3493 |
| 6 | (12.70) .500 | (15.21) .599 | 14-56-8062 | A-70400-3494 |
| 7 | (15.24) .600 | (17.75) .699 | 14-56-8072 | A-70400-3495 |
| 8 | (17.78) .700 | (20.29) .799 | 14-56-8082 | A-70400-3496 |
| 9 | (20.32) .800 | (22.83) .899 | 14-56-8092 | A-70400-3497 |
| 10 | (22.86) .900 | (25.37) .999 | 14-56-8102 | A-70400-3498 |
| 11 | (25.54) 1.000 | (27.91) 1.099 | 14-56-8112 | A-70400-3499 |
| 12 | (27.94) 1.100 | (30.45) 1.199 | 14-56-8122 | A-70400-3500 |
| 13 | (30.48) 1.200 | (32.99) 1.299 | 14-56-8132 | A-70400-3501 |
| 14 | (33.02) 1.300 | (35.53) 1.399 | 14-56-8142 | A-70400-3502 |
| 15 | (35.56) 1.400 | (38.07) 1.499 | 14-56-8152 | A-70400-3503 |
| 16 | (38.01) 1.500 | (40.61) 1.599 | 14-56-8162 | A-70400-3504 |
| 17 | (40.64) 1.600 | (43.15) 1.699 | 14-56-8172 | A-70400-3505 |
| 18 | (43.18) 1.700 | (45.69) 1.799 | 14-56-8182 | A-70400-3506 |
| 19 | (45.72) 1.800 | (48.23) 1.899 | 14-56-8192 | A-70400-3507 |
| 20 | (48.26) 1.900 | (50.77) 1.999 | 14-56-8202 | A-70400-3508 |
| 21 | (50.80) 2.000 | (53.31) 2.099 | 14-56-8212 | A-70400-3509 |
| 22 | (53.34) 2.100 | (55.85) 2.199 | 14-56-8222 | A-70400-3510 |
| 23 | (55.88) 2.200 | (58.39) 2.299 | 14-56-8232 | A-70400-3511 |
| 24 | (58.42) 2.300 | (60.93) 2.399 | 14-56-8242 | A-70400-3512 |
| 25 | (60.96) 2.400 | (63.47) 2.499 | 14-56-8252 | A-70400-3513 |

| LTR. | REVISIONS | LTR. | REVISIONS |
|------|----------------------------------------|------|-------------------------------------|
| | E I | | |
| | E | | |
| F | LEAD FREE UCP2004-1769 RWHITE 04/03/22 | D | REVISED PER ECN# U90726 7-10-89 MGB |

| DIMENSIONS SHOWN (METRIC) INCH UNLESS OTHERWISE SPECIFIED TOLERANCES: ANGULAR ± 1/2° | |
|--------------------------------------------------------------------------------------|--------|
| INCH | METRIC |
| 3 PLACE ± .010 | --- |
| 2 PLACE ± .014 | ± 0.25 |
| 1 PLACE --- | ± 0.35 |

| MFG. SH. REV. | | REVISE ONLY ON CAD SYSTEM | |
|-------------------------------------------------------------|--------------|------------------------------------------------------------------------------------------------------------------------|------------------------|
| TITLE ASSEMBLY, SL CONNECTOR (SINGLE ROW- (2.54)/.100 GRID) | | | |
| MOLEX INCORPORATED LISLE, ILL. 60532 U.S.A. | | SHEET NO. 60532 | DATE 10/26/87 |
| PART NO. SDA-70400-3490-3513 | | DRWG. NO. SDA-70400-3490-3513 | |
| FILE NAME 74003490.DGN | | THIS DRAWING CONTAINS INFORMATION THAT IS PROPRIETARY TO MOLEX INC. AND SHOULD NOT BE USED WITHOUT WRITTEN PERMISSION. | |
| DRWG. BY AAB | CHK'D BY WAZ | SCALE 4:1 | FILE NAME 74003490.DGN |