

1. THIS SPECIFICATION SHALL COVER THE CHARACTERISTICS OF CERAMIC FILTER WITH 450KHz, INTENDED FOR USE IN TRANSCEIVERS, ETC.

2. PART NUMBER: LT450EW

3. ELECTRICAL SPECIFICATIONS

- A. CENTRE FREQUENCY(f_0) : 450 KHz \pm 1.5KHz
- B. BAND WIDTH AT 6 dB : \pm 7.5 KHz MIN.(TO 450KHz)
- C. BAND WIDTH AT 50 dB : \pm 15.0 KHz MAX.(TO 450KHz)
- D. STOP BAND ATTENUATION : 40 dB MIN.(AT $f_0 \pm 100$ KHz)
- E. RIPPLE : 2.0 dB MAX.(AT $f_0 \pm 5.0$ KHz)
- F. INSERTION LOSS : 6.0 dB MAX.(AT THE SMALLEST LOSS)
- G TEMPERATURE COEFFICIENT OF CENTER FREQUENCY : \pm 50PPM/ $^{\circ}$ C Max.(-20 TO +80 $^{\circ}$ C)
- H. INPUT/OUTPUT IMPEDANCE : 1.5 K Ω

NOTE : A) CENTER FREQUENCY SHALL BE DEFINED AS THE CENTRAL VALUE OF THE BAND WITH AL 6 dB

B) TEMPERATURE COEFFICIENT OF CENTER FREQUENCY SHALL BE DEFINED AS THE AVERAGE OF THE CENTRAL FREQUENCY.

4. MEASUREMENT

A. ENVIRONMENTAL CONDITION

MEASUREMENT SHALL BE CARRIED OUT AT THE REFERENCE TEMPERATURE OF 25 $^{\circ}$ C \pm 2 $^{\circ}$ C. IT SHALL BE POSSIBLY DONE AT 5 $^{\circ}$ C TO 35 $^{\circ}$ C UNLESS IT IS QUESTIONABLE.

B. MEASURING CIRCUIT

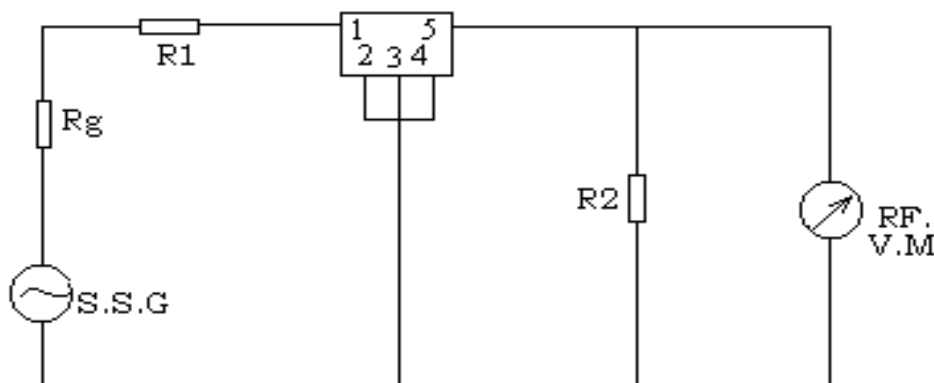

$$R_g + R_1 = R_2 = \text{input/output Impedance}$$

S.S.G. (STANDARD SIGNAL GENERATION)

R.F.V.M. (RADIO FREQUENCY VOLTAGE METER)

$R_g + R_1 = R_2 = 1.5K\Omega$

$C < = 50PF$

5. DIMENSIONS(mm)

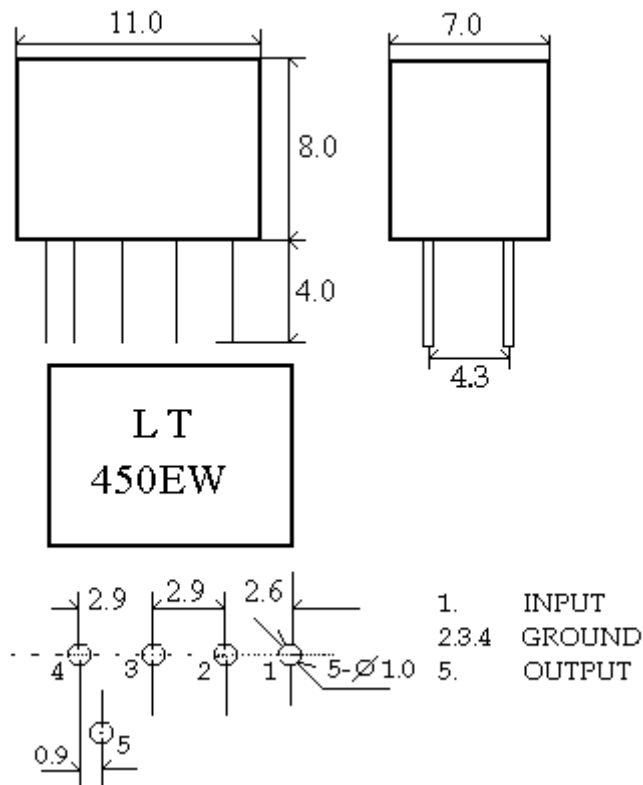

6. ENVIRONMENTAL CHARACTERISTICS

6-1 HIGH TEMPERATURE EXPOSURE

SUBJECT THE FILTER TO $+80^{\circ}C$ FOR 96 HOURS. THEN RELEASE THE FILTER INTO THE SPECIFICATIONS IN TABLE 1.

6-2 MOISURE

KEEP THE FILTER AT $40^{\circ}C$ AND 95%RH FOR 96 HOURS. THEN RELEASE THE FILTER INTO THE ROOM CONDITIONS FOR 1 TO 2 HOURS PRIOR TO THE MEASUREMENT. IT SHALL FULFILL THE SPECIFICATIONS IN TABLE 1.

6-3 LOW TEMPERATURE EXPOSURE

SUBJECT THE FILTER TO $-20^{\circ}C$ FOR 96 HOURS. THEN RELEASE THE FILTER INTO THE ROOM CONDITIONS FOR 1 TO 2 HOURS PRIOR TO THE MEASUREMENT. IT SHALL FULFILL THE SPECIFICATIONS IN TABLE 1.

- 6-4 TEMPERATURE CYCLING
 SUBJECT THE FILTER TO A LOW TEMPERATURE OF -55°C FOR 30 MINUTES. FOLLOWING BY A HIGH TEMPERATURE OF $+85^{\circ}\text{C}$ FOR 30 MINUTES. THEN RELEASE THE FILTER INTO THE ROOM CONDITIONS FOR 1 TO 2 HOURS PRIOR TO THE MEASUREMENT. IT SHALL MEET THE SPECIFICATIONS IN TABLE 1.
- 6-5 RESISTANCE TO SOLDER HEAT
 DIP THE FILTER TERMINALS NO CLOSER THAN 1.5mm INTO THE SOLDER BATH AT $270^{\circ}\text{C} \pm 10^{\circ}\text{C}$ FOR 10 ± 1 SEC. THEN RELEASE THE FILTER INTO THE ROOM CONDITIONS FOR 1 TO 2 HOURS. THE FILTER SHALL MEET THE SPECIFICATIONS IN TABLE 1.
- 6-6 MECHANICAL SHOCK
 DROP THE FILTER RANDOMLY ONTO THE CONCRETE FLOOR FROM THE HEIGHT OF 30cm 3 TIMES. THE FILTER SHALL FULFILL THE SPECIFICATIONS IN TABLE 1.
- 6-7 VIBRATION
 SUBJECT THE FILTER TO THE VIBRATION FOR 1 HOUR EACH IN X, Y AND Z AXES WITH THE AMPLITUDE OF 1.5mm AT 10 TO 55Hz. THE FILTER SHALL FULFILL THE SPECIFICATIONS IN TABLE 1.
- 6-8 LEAD FATIGUE
- 6-8-1 PULLING TEST
 WEIGHT ALONG WITH THE DIRECTION OF LEAD WITHOUT AN SHOCK 3 KG. THE FILTER SHALL SATISFY ALL THE INITIAL CHARACTERISTICS.
- 6-8-2 BENDING TEST
 LEAD SHALL BE SUBJECT TO WITHSTAND AGAINST 90°C BENDING IN THE DIRECTION OF THICKNESS. THIS OPERATION SHALL BE DONE TOWARD BOTH DIRECTION. THE FILTER SHALL SHOW NO EVIDENCE OF DAMAGE AND SHALL SATISFY ALL THE INITIAL ELECTRICAL CHARACTERISTICS.

TABLE 1

ITEM	SPECIFICATION
CENTRE FREQUENCY(f_0)	450 ± 1.5 KHz Max
BAND WIDTH(6 dB)	± 7.5 KHz Min
SELECTIVITY(50 dB)	± 15.0 KHz Max
STOP BAND ATTENUATION	40 dB Min
RIPPLE	2.0 dB Max
INSERTION LOSS	6.0 dB Max