

DASH NO.	DESCRIPTION	MADE FROM
----------	-------------	-----------

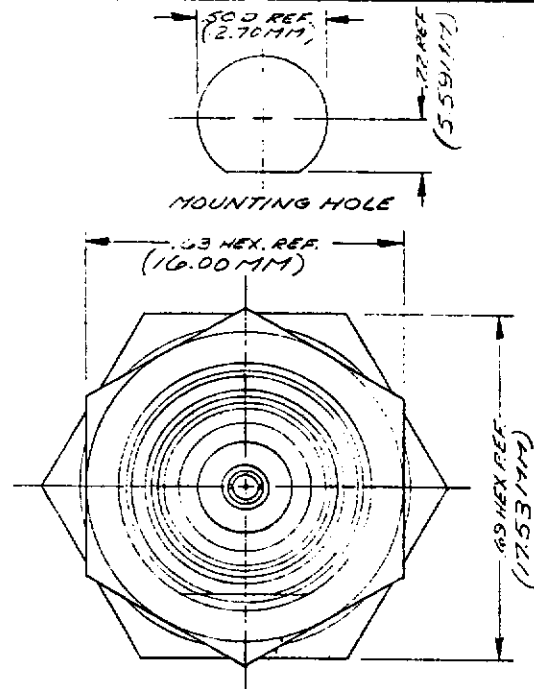
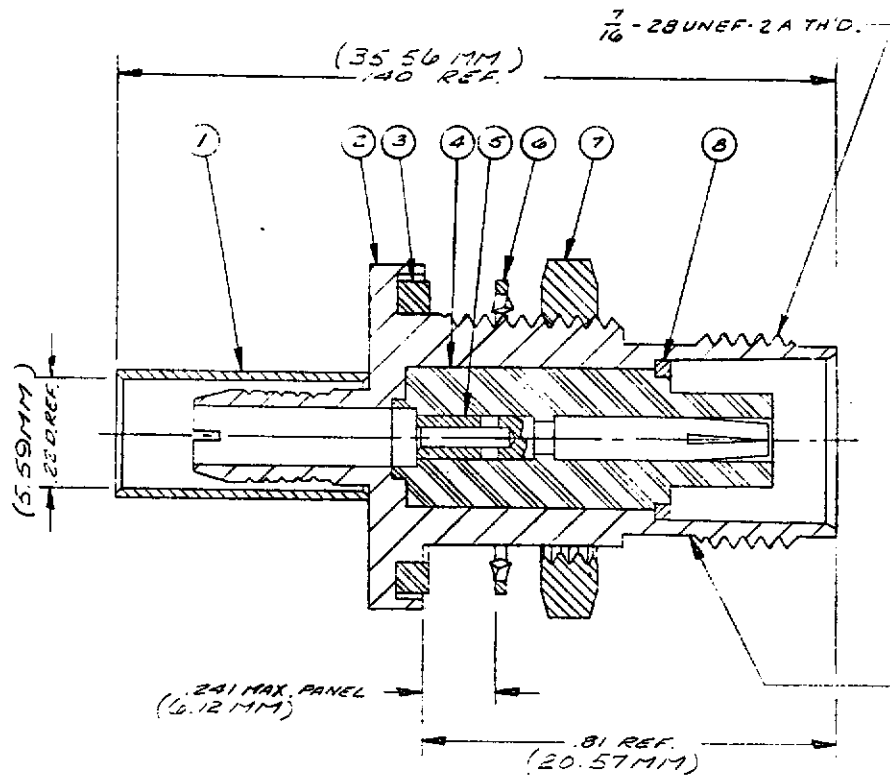

STAMP: 91836 M39012/28-0503
 KA-15-152 XXXX
 DATE CODE

NOTES:

- FOR USE WITH RG-142, 223 & 400 U.C. CABLE GROUPS.
- FOR CABLE TRIMMING USE KTJ-113 & KTD-166.
- FOR FORMING USE CRIMP DIE SIZE 01.
- FOR CABLING INSTRUCTIONS SEE CP-465.
- ITEM 5 TO BE SUPPLIED UNASSEMBLED.

S-D

UNLESS OTHERWISE SPECIFIED:

- TOLERANCES: FRACTIONS & 2 PLACE DECIMALS \pm .010
3 PLACE DECIMALS \pm .004
T. I. R. CONCENTRICITY OF ANY 2 DIAMETERS MAY NOT EXCEED HALF THE SUM OF THEIR TOLERANCES.
- REMOVE ALL BURRS. BREAK SHARP EDGES .005 MAX.
- NO FILLETS PERMITTED.
- SURFACE ROUGHNESS 63 MICROINCHES RMS MAX.
- ALL DIMENSIONS PRIOR TO PLATING.

M39012/28-0503

REVISIONS	
ISSUE	CHANGES
0	ER 13441 JL 22 JUL 74
1	CN 13089 A GA 5 AUG 74
2	CN 13241 A MJE 1 OCT 74
3	CN 21633 C PAS 23 FEB 81
4	CN 22767 E JEP 17 NOV 81
5	CN 25533 D MJB 15 DEC 83
6	CN 32302 A LNM 20 JUN 90

S-D

KA-15-152

USED ON:

REF:

FINISH

SPEC. KER 10009

MATL:

SPEC.
TNC BULK HEAD JACK

DRAWN JL DATE 23 MAY 74

APPR. LI DATE 22 JUL 74

KINGS ELECTRONICS
40 MARBLEDALE ROAD
TUCKAHOE, N. Y. 10707

M39012/28-0503

ITEM	REQ'D	DESCRIPTION	PART NO.
9	1	CABLING INSTRUCTIONS	
8	1	RETAINING RING	
7	1	HEX NUT	492A-9-MC7
6	1	LOCKWASHER	492A-12-MC7
5	1	BNC CRIMP CAPTIVE CONTACT	1-5017-34M9D
4	1	INSULATOR	
3	1	GASKET	492A-10-M9A
2	1	K-GRIP BODY	
1	1	K-GRIP SLEEVE	5-89-05-2MCT

S-D