

# PLL frequency synthesizer for tuners

## BU2611A / BU2611AF / BU2611AFS

The BU2611 PLL frequency synthesizers work up through the FM band. They feature built-in RF amps with low power dissipation and high sensitivity.

### ●Applications

Tuners (Mini components, radio cassette players, radio equipment, etc.)

### ●Features

- 1) Built-in high-speed prescaler can divide 130MHzVCO.
- 2) In addition to the reference FM and AM, also offers the following 7 frequencies : 100kHz, 50kHz, 25kHz, 10kHz, 9kHz, 5kHz, and 1kHz.
- 3) 3-bit output port (open drain).
- 4) Clock output (400kHz).
- 5) Time base output (8Hz).
- 6) Serial data input (CE, CK, DA).

### ●Absolute maximum ratings (Ta = 25°C)

Parameter		Symbol	Limits	Unit	Conditions
Power supply voltage		V <sub>DD</sub>	-0.3~+7.0	V	
Maximum input voltage		V <sub>IN</sub>	-0.3~V <sub>DD</sub> +0.3	V	CE, CK, CA, XIN, FMIN, AMIN
Maximum output voltage 1		V <sub>OUT1</sub>	-0.3~+10.0	V	P1, P2, P3, P4
Maximum output voltage 2		V <sub>OUT2</sub>	-0.3~V <sub>DD</sub> +0.3	V	PD1, PD2
Maximum output current		I <sub>OUT</sub>	0~+4.0	mA	P1, P2, P3, P4
Power dissipation	BU2611A	Pd	1000 *1	mW	
	BU2611AF/BU2611AFS		500 *2		
Operating temperature		T <sub>opr</sub>	-25~+75	°C	
Storage temperature		T <sub>stg</sub>	-55~+125	°C	

\*1 Reduced by 10mW for each increase in Ta of 1°C over 25°C.

\*2 Reduced by 5mW for each increase in Ta of 1°C over 25°C.

### ●Recommended operating conditions

Parameter	Symbol	Min.	Typ.	Max.	Unit
Power supply voltage	V <sub>DD</sub>	4.0	-	6.0	V

# BU2611A / BU2611AF / BU2611AFS

## Audio ICs

### ●Block diagram

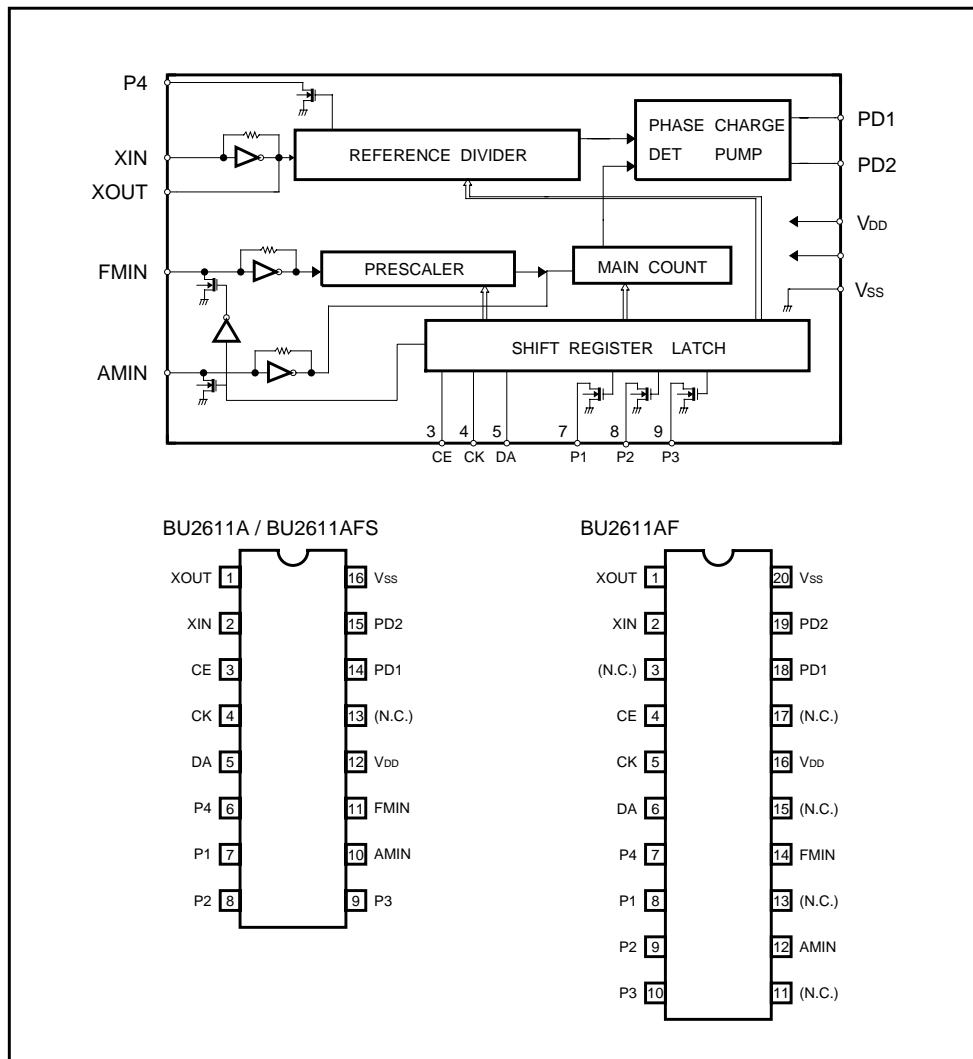

### ●Pin descriptions

Pin name	Functions
P4	Controller clock (400kHz) output
XIN, XOUT	X'tal oscillation (7.2MHz)
FMIN, AMIN	Local oscillation signal input
CE, CK, DA	Data input
P1, P2, P3	Output port
V	Power supply
PD1, PD2	Charge pump output

# BU2611A / BU2611AF / BU2611AFS

## Audio ICs

### ●Electrical characteristics (unless otherwise noted, Ta = 25°C, V<sub>DD</sub> = 5.0V)

Parameter	Symbol	Min.	Typ.	Max.	Unit	Conditions
Power supply current	I <sub>DD1</sub>	–	4.8	–	mA	F <sub>IN</sub> =130MHz, 100mVrms
Circuit current w/o signal	I <sub>DD2</sub>	–	300	–	μA	No input, PLL=OFF
Input high level voltage	V <sub>IH</sub>	3.5	–	–	V	CE, CK, DA terminals
Input low level voltage	V <sub>IL</sub>	–	–	1.5	V	CE, CK, DA terminals
Output low level voltage 1	V <sub>OL1</sub>	–	0.4	–	V	P1, P2, P3, P4 I <sub>OUT</sub> =2.0mA
Off level leakage current 1	I <sub>OFF1</sub>	–	–	1.0	μA	P1, P2, P3, P4 V <sub>OUT</sub> =10V
Output high level voltage	V <sub>OH</sub>	–	0.25	–	V	PD1, PD2 I <sub>OUT</sub> =-1.0mA
Output low level voltage 2	V <sub>OL2</sub>	–	0.15	–	V	PD1, PD2 I <sub>OUT</sub> =1.0mA
Off level leakage current 2	I <sub>OFF2</sub>	100	–	100	nA	PD1, PD2 V <sub>OUT</sub> =V <sub>DD</sub>
Off level leakage current 3	I <sub>OFF3</sub>	-100	–	–	nA	PD1, PD2 V <sub>OUT</sub> =V <sub>SS</sub>
Input frequency 1	F <sub>IN1</sub>	–	7.2	–	MHz	XIN, sine wave, C coupling
Input frequency 2	F <sub>IN2</sub>	10	–	130	MHz	FMIN, sine wave, C coupling V <sub>IN</sub> =80mVrms
Input frequency 3	F <sub>IN3</sub>	0.5	–	20	MHz	AMIN, sine wave, C coupling V <sub>IN</sub> =80mVrms
Input amplitude	F <sub>INMax.</sub>	0.08	–	1.5	Vrms	XIN, FMIN, AMIN, sine wave, C coupling

### ●Data format

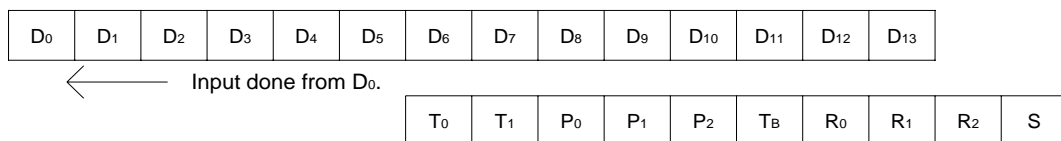
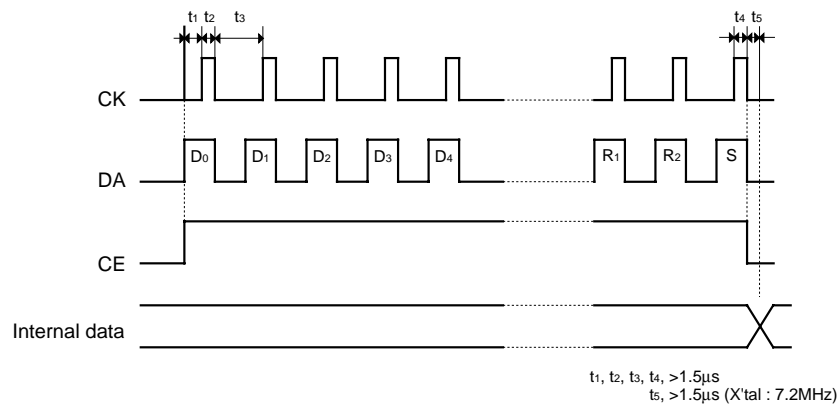

(1) Division data : For D<sub>0</sub> through D<sub>13</sub> (For AMN, use D<sub>4</sub> through D<sub>13</sub>).

D <sub>0</sub>	D <sub>1</sub>	D <sub>2</sub>	D <sub>3</sub>	D <sub>4</sub>	D <sub>5</sub>	D <sub>6</sub>	D <sub>7</sub>	D <sub>8</sub>	D <sub>9</sub>	D <sub>10</sub>	D <sub>11</sub>	D <sub>12</sub>	D <sub>13</sub>	
1	1	0	0	1	0	1	0	0	0	1	0	0	0	→FMIN frequency=1107
X	X	X	X	0	1	1	1	1	0	0	1	1	1	→AMIN frequency=926

## Audio ICs

(2) Test data : T<sub>0</sub> through T<sub>1</sub> are taken as (0, 0).

(3) P<sub>0</sub>, P<sub>1</sub>, P<sub>2</sub>, P<sub>3</sub>, TB : port output, time base output

Data				Port output		
P <sub>0</sub>	P <sub>1</sub>	P <sub>2</sub>	TB	P <sub>1</sub>	P <sub>2</sub>	P <sub>3</sub>
0	0	0	0	*	*	*
0	0	1	0	0	0	1
0	1	0	0	0	1	0
0	1	1	0	0	1	1
1	0	0	0	1	0	0
1	0	1	0	1	0	1
1	1	0	0	1	1	0
1	1	1	0	1	1	1
0	0	0	1	TB	*	*
X	1	0	1	TB	1	0
X	0	1	1	TB	0	1
X	1	1	1	TB	1	1
1	0	0	1	TB	0	0

\* : Determined on the basis of R<sub>0</sub> - R<sub>2</sub>.

X : Irrelevant

TB: 8 Hz

(4) R<sub>0</sub>, R<sub>1</sub>, R<sub>2</sub>, standard frequency data

Data				Port output		
R <sub>0</sub>	R <sub>1</sub>	R <sub>2</sub>	Standard frequency	P <sub>1</sub>	P <sub>2</sub>	P <sub>3</sub>
0	0	0	100kHz	1	1	0
0	0	1	50kHz	1	1	0
0	1	0	25kHz	1	1	0
0	1	1	5kHz	0	0	1
1	0	0	10kHz	1	0	1
1	0	1	9kHz	1	0	1
1	1	0	1kHz	0	1	1
1	1	1	5kHz	0	0	1

(5) S : input selection data 1 : FMIN 0 : AMIN

# BU2611A / BU2611AF / BU2611AFS

## Audio ICs

### ●External dimensions (Units : mm)

