

SOT-23

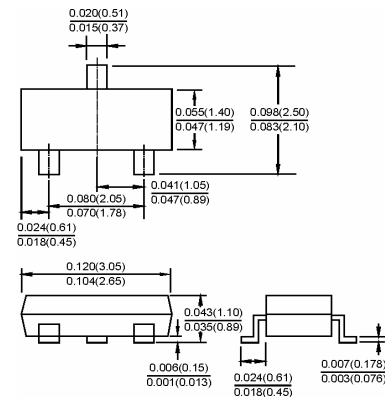

Dimensions in inches and (millimeters)

Features

- ✧ For high-speed switching application.
- ✧ Connected in series.

Applications

- ✧ High speed switching application.

Ordering Information

Type No.	Marking	Package Code
MMBD7000	M5C	SOT-23

MAXIMUM RATING @ Ta=25°C unless otherwise specified

Characteristic	Symbol	Limits	Unit
Non-Repetitive Peak Reverse Voltage	V_{RM}	100	V
DC Reverse Voltage	V_R	100	V
Forward Current	I_F	200	mA
Surge forward Current, $t=1\mu s$	I_{FS}	4.5	A
Power Dissipation	P_d	330	mW
Operating Junction Temperature Range	T_j	150	°C
Storage Temperature Range	T_{STG}	-65 to +150	°C

ELECTRICAL CHARACTERISTICS @ Ta=25°C unless otherwise specified

Characteristic	Symbol	Min	MAX	UNIT	Test Condition
Reverse Breakdown Voltage	$V_{(BR)R}$	100		V	$I_R=100\mu A$
Forward Voltage	V_F	0.55 0.67 0.75	0.7 0.82 1.1	V	$I_F=1mA$ $I_F=10mA$ $I_F=100mA$
Reverse Leakage Current	I_R		300 500	nA	$V_R=50V$ $V_R=100V$
Diode Capacitance	C_D		2	pF	$V_R=0V, f=1MHz$
Reverse Recovery Time	t_{rr}		15	ns	$I_F=I_R=10mA$ $R_L=100\Omega$

TYPICAL CHARACTERISTICS @ $T_a=25^\circ\text{C}$ unless otherwise specified

