



Freescale Semiconductor, Inc.

*MC68HC908MR32
MC68HC908MR16*

Data Sheet

*M68HC08
Microcontrollers*

*MC68HC908MR32/D
Rev. 6.0
11/2003*

MOTOROLA.COM/SEMICONDUCTORS

Freescale Semiconductor, Inc.

Freescale Semiconductor, Inc.

**For More Information On This Product,
Go to: www.freescale.com**

MC68HC908MR32

MC68HC908MR16

Data Sheet

To provide the most up-to-date information, the revision of our documents on the World Wide Web will be the most current. Your printed copy may be an earlier revision. To verify you have the latest information available, refer to:

<http://motorola.com/semiconductors>

The following revision history table summarizes changes contained in this document. For your convenience, the page number designators have been linked to the appropriate location.

Motorola and the Stylized M Logo are registered trademarks of Motorola, Inc.

DigitalDNA is a trademark of Motorola, Inc.

This product incorporates SuperFlash® technology licensed from SST.

© Motorola, Inc., 2003

Revision History

Revision History

Date	Revision Level	Description	Page Number(s)
August, 2001	3.0	Figure 2-1. MC68HC908MR32 Memory Map — Added FLASH Block Protect Register (FLBPR) at address location \$FF7E	29
		Figure A-1. MC68HC908MR16 Memory Map — Added FLASH Block Protect Register (FLBPR) at address location \$FF7E	306
October, 2001	4.0	3.3.3 Conversion Time — Reworked equations and text for clarity.	50
December, 2001	5.0	Figure 18-8. Monitor Mode Circuit — PTA7 and connecting circuitry added	279
		Table 18-2. Monitor Mode Signal Requirements and Options — Switch locations added to column headings for clarity	281
		Section 16. Timer Interface A (TIMA) — Timer discrepancies corrected throughout this section.	233
		Section 17. Timer Interface B (TIMB) — Timer discrepancies corrected throughout this section.	255
November, 2003	6.0	Reformatted to meet current publication standards	Throughout
		2.8.2 FLASH Page Erase Operation — Procedure reworked for clarity	42
		2.8.3 FLASH Mass Erase Operation — Procedure reworked for clarity	42
		2.8.4 FLASH Program Operation — Procedure reworked for clarity	43
		Figure 14-14. SIM Break Status Register (SBSR) — Clarified definition of SBSW bit.	207
		19.5 DC Electrical Characteristics — Corrected maximum value for monitor mode entry voltage (on \overline{IRQ})	291
		19.6 FLASH Memory Characteristics — Updated table entries	292

List of Sections

Section 1. General Description	19
Section 2. Memory	27
Section 3. Analog-to-Digital Converter (ADC)	47
Section 4. Clock Generator Module (CGM)	59
Section 5. Configuration Register (CONFIG)	79
Section 6. Computer Operating Properly (COP)	83
Section 7. Central Processor Unit (CPU)	87
Section 8. External Interrupt (IRQ)	101
Section 9. Low-Voltage Inhibit (LVI)	107
Section 10. Input/Output (I/O) Ports (PORTS)	111
Section 11. Power-On Reset (POR)	125
Section 12. Pulse-Width Modulator for Motor Control (PWMMC)	127
Section 13. Serial Communications Interface Module (SCI)	169
Section 14. System Integration Module (SIM)	195
Section 15. Serial Peripheral Interface Module (SPI)	209
Section 16. Timer Interface A (TIMA)	233
Section 17. Timer Interface B (TIMB)	255
Section 18. Development Support	273
Section 19. Electrical Specifications	289
Section 20. Ordering Information and Mechanical Specifications	301
Appendix A. MC68HC908MR16	305

Table of Contents

Section 1. General Description

1.1 Introduction 19

1.2 Features 19

1.3 MCU Block Diagram 20

1.4 Pin Assignments 22

1.4.1 Power Supply Pins (V_{DD} and V_{SS}) 24

1.4.2 Oscillator Pins (OSC1 and OSC2) 24

1.4.3 External Reset Pin (\overline{RST}) 24

1.4.4 External Interrupt Pin (\overline{IRQ}) 24

1.4.5 CGM Power Supply Pins (V_{DDA} and V_{SSAD}) 25

1.4.6 External Filter Capacitor Pin (CGMXFC) 25

1.4.7 Analog Power Supply Pins (V_{DDAD} and V_{SSAD}) 25

1.4.8 ADC Voltage Decoupling Capacitor Pin (V_{REFH}) 25

1.4.9 ADC Voltage Reference Low Pin (V_{REFL}) 25

1.4.10 Port A Input/Output (I/O) Pins (PTA7–PTA0) 25

1.4.11 Port B I/O Pins (PTB7/ATD7–PTB0/ATD0) 25

1.4.12 Port C I/O Pins (PTC6–PTC2 and PTC1/ATD9–PTC0/ATD8) 25

1.4.13 Port D Input-Only Pins (PTD6/ $\overline{IS3}$ –PTD4/ $\overline{IS1}$
and PTD3/FAULT4–PTD0/FAULT1) 26

1.4.14 PWM Pins (PWM6–PWM1) 26

1.4.15 PWM Ground Pin (PWMGND) 26

1.4.16 Port E I/O Pins (PTE7/TCH3A–PTE3/TCLKA
and PTE2/TCH1B–PTE0/TCLKB) 26

1.4.17 Port F I/O Pins (PTF5/TxD–PTF4/RxD
and PTF3/MISO–PTF0/SPSCK) 26

Section 2. Memory

2.1 Introduction 27

2.2 Unimplemented Memory Locations 27

2.3 Reserved Memory Locations 27

2.4 I/O Section 28

2.5 Memory Map 28

2.6 Monitor ROM 39

2.7 Random-Access Memory (RAM) 39

2.8	FLASH Memory (FLASH)	40
2.8.1	FLASH Control Register	41
2.8.2	FLASH Page Erase Operation	42
2.8.3	FLASH Mass Erase Operation	42
2.8.4	FLASH Program Operation	43
2.8.5	FLASH Block Protection	45
2.8.6	FLASH Block Protect Register	45
2.8.7	Wait Mode	46
2.8.8	Stop Mode	46

Section 3. Analog-to-Digital Converter (ADC)

3.1	Introduction	47
3.2	Features	47
3.3	Functional Description	47
3.3.1	ADC Port I/O Pins	49
3.3.2	Voltage Conversion	49
3.3.3	Conversion Time	50
3.3.4	Continuous Conversion	50
3.3.5	Result Justification	50
3.3.6	Monotonicity	52
3.4	Interrupts	52
3.5	Wait Mode	52
3.6	I/O Signals	52
3.6.1	ADC Analog Power Pin (V_{DDAD})	52
3.6.2	ADC Analog Ground Pin (V_{SSAD})	52
3.6.3	ADC Voltage Reference Pin (V_{REFH})	52
3.6.4	ADC Voltage Reference Low Pin (V_{REFL})	53
3.6.5	ADC Voltage In (ADVIN)	53
3.6.6	ADC External Connections	53
3.6.6.1	V_{REFH} and V_{REFL}	53
3.6.6.2	ANx	53
3.6.6.3	Grounding	53
3.7	I/O Registers	54
3.7.1	ADC Status and Control Register	54
3.7.2	ADC Data Register High	56
3.7.3	ADC Data Register Low	56
3.7.4	ADC Clock Register	57

Section 4. Clock Generator Module (CGM)

4.1	Introduction	59
4.2	Features	59
4.3	Functional Description	59
4.3.1	Crystal Oscillator Circuit	61
4.3.2	Phase-Locked Loop Circuit (PLL)	61
4.3.2.1	PLL Circuits	61
4.3.2.2	Acquisition and Tracking Modes	62
4.3.2.3	Manual and Automatic PLL Bandwidth Modes	62
4.3.2.4	Programming the PLL	64
4.3.2.5	Special Programming Exceptions	65
4.3.3	Base Clock Selector Circuit	65
4.3.4	CGM External Connections	66
4.4	I/O Signals	67
4.4.1	Crystal Amplifier Input Pin (OSC1)	67
4.4.2	Crystal Amplifier Output Pin (OSC2)	67
4.4.3	External Filter Capacitor Pin (CGMXFC)	67
4.4.4	PLL Analog Power Pin (V_{DDA})	67
4.4.5	Oscillator Enable Signal (SIMOSCEN)	67
4.4.6	Crystal Output Frequency Signal (CGMXCLK)	68
4.4.7	CGM Base Clock Output (CGMOUT)	68
4.4.8	CGM CPU Interrupt (CGMINT)	68
4.5	CGM Registers	68
4.5.1	PLL Control Register	69
4.5.2	PLL Bandwidth Control Register	70
4.5.3	PLL Programming Register	72
4.6	Interrupts	73
4.7	Wait Mode	73
4.8	Acquisition/Lock Time Specifications	74
4.8.1	Acquisition/Lock Time Definitions	74
4.8.2	Parametric Influences on Reaction Time	75
4.8.3	Choosing a Filter Capacitor	75
4.8.4	Reaction Time Calculation	76

Section 5. Configuration Register (CONFIG)

5.1	Introduction	79
5.2	Functional Description	79
5.3	Configuration Register	80

Section 6. Computer Operating Properly (COP)

6.1	Introduction	83
6.2	Functional Description	83
6.3	I/O Signals	84
6.3.1	CGMXCLK	84
6.3.2	COPCTL Write	84
6.3.3	Power-On Reset	84
6.3.4	Internal Reset	84
6.3.5	Reset Vector Fetch	85
6.3.6	COPD (COP Disable)	85
6.4	COP Control Register	85
6.5	Interrupts	85
6.6	Monitor Mode	85
6.7	Wait Mode	85
6.8	Stop Mode	85

Section 7. Central Processor Unit (CPU)

7.1	Introduction	87
7.2	Features	87
7.3	CPU Registers	88
7.3.1	Accumulator	88
7.3.2	Index Register	89
7.3.3	Stack Pointer	89
7.3.4	Program Counter	90
7.3.5	Condition Code Register	90
7.4	Arithmetic/Logic Unit (ALU)	92
7.5	Low-Power Modes	92
7.5.1	Wait Mode	92
7.5.2	Stop Mode	92
7.6	CPU During Break Interrupts	92
7.7	Instruction Set Summary	93
7.8	Opcode Map	99

Section 8. External Interrupt (IRQ)

8.1	Introduction	101
8.2	Features	101
8.3	Functional Description	101
8.4	$\overline{\text{IRQ}}$ Pin	104
8.5	$\overline{\text{IRQ}}$ Pin	104
8.6	IRQ Status and Control Register	105

Section 9. Low-Voltage Inhibit (LVI)

9.1	Introduction	107
9.2	Features	107
9.3	Functional Description	107
9.3.1	Polled LVI Operation	108
9.3.2	Forced Reset Operation	108
9.3.3	False Reset Protection	108
9.3.4	LVI Trip Selection	109
9.4	LVI Status and Control Register	109
9.5	LVI Interrupts	110
9.6	Wait Mode	110
9.7	Stop Mode	110

Section 10. Input/Output (I/O) Ports (PORTS)

10.1	Introduction	111
10.2	Port A	113
10.2.1	Port A Data Register	113
10.2.2	Data Direction Register A	113
10.3	Port B	115
10.3.1	Port B Data Register	115
10.3.2	Data Direction Register B	115
10.4	Port C	117
10.4.1	Port C Data Register	117
10.4.2	Data Direction Register C	117
10.5	Port D	119
10.6	Port E	120
10.6.1	Port E Data Register	120
10.6.2	Data Direction Register E	120
10.7	Port F	122
10.7.1	Port F Data Register	122
10.7.2	Data Direction Register F	122

Section 11. Power-On Reset (POR)

11.1	Introduction	125
11.2	Functional Description	125

Section 12. Pulse-Width Modulator for Motor Control (PWMMC)

12.1	Introduction	127
12.2	Features	127
12.3	Timebase	132
12.3.1	Resolution	132
12.3.2	Prescaler	134
12.4	PWM Generators	134
12.4.1	Load Operation	134
12.4.2	PWM Data Overflow and Underflow Conditions	137
12.5	Output Control	138
12.5.1	Selecting Six Independent PWMs or Three Complementary PWM Pairs	138
12.5.2	Dead-Time Insertion	139
12.5.3	Top/Bottom Correction with Motor Phase Current Polarity Sensing	142
12.5.4	Output Polarity	145
12.5.5	PWM Output Port Control	146
12.6	Fault Protection	149
12.6.1	Fault Condition Input Pins	149
12.6.1.1	Fault Pin Filter	151
12.6.1.2	Automatic Mode	151
12.6.1.3	Manual Mode	152
12.6.2	Software Output Disable	153
12.6.3	Output Port Control	153
12.7	Initialization and the PWMEN Bit	154
12.8	PWM Operation in Wait Mode	155
12.9	Control Logic Block	155
12.9.1	PWM Counter Registers	155
12.9.2	PWM Counter Modulo Registers	156
12.9.3	PWMx Value Registers	157
12.9.4	PWM Control Register 1	158
12.9.5	PWM Control Register 2	160
12.9.6	Dead-Time Write-Once Register	162
12.9.7	PWM Disable Mapping Write-Once Register	162
12.9.8	Fault Control Register	162
12.9.9	Fault Status Register	164
12.9.10	Fault Acknowledge Register	165
12.9.11	PWM Output Control Register	166
12.10	PWM Glossary	167

Section 13. Serial Communications Interface Module (SCI)

13.1	Introduction	169
13.2	Features	169
13.3	Functional Description	171
13.3.1	Data Format	172
13.3.2	Transmitter	173
13.3.2.1	Character Length	174
13.3.2.2	Character Transmission	174
13.3.2.3	Break Characters	174
13.3.2.4	Idle Characters	175
13.3.2.5	Inversion of Transmitted Output	175
13.3.2.6	Transmitter Interrupts	176
13.3.3	Receiver	176
13.3.3.1	Character Length	176
13.3.3.2	Character Reception	176
13.3.3.3	Data Sampling	176
13.3.3.4	Framing Errors	180
13.3.3.5	Receiver Wakeup	180
13.3.3.6	Receiver Interrupts	180
13.3.3.7	Error Interrupts	181
13.4	Wait Mode	181
13.5	SCI During Break Module Interrupts	181
13.6	I/O Signals	182
13.6.1	PTF5/TxD (Transmit Data)	182
13.6.2	PTF4/RxD (Receive Data)	182
13.7	I/O Registers	182
13.7.1	SCI Control Register 1	182
13.7.2	SCI Control Register 2	185
13.7.3	SCI Control Register 3	187
13.7.4	SCI Status Register 1	188
13.7.5	SCI Status Register 2	191
13.7.6	SCI Data Register	192
13.7.7	SCI Baud Rate Register	192

Section 14. System Integration Module (SIM)

14.1	Introduction	195
14.2	SIM Bus Clock Control and Generation	197
14.2.1	Bus Timing	197
14.2.2	Clock Startup from POR or LVI Reset	197
14.2.3	Clocks in Wait Mode	197

14.3	Reset and System Initialization	198
14.3.1	External Pin Reset	198
14.3.2	Active Resets from Internal Sources	199
14.3.2.1	Power-On Reset (POR)	199
14.3.2.2	Computer Operating Properly (COP) Reset	200
14.3.2.3	Illegal Opcode Reset	201
14.3.2.4	Illegal Address Reset	201
14.3.2.5	Forced Monitor Mode Entry Reset (MENRST)	201
14.3.2.6	Low-Voltage Inhibit (LVI) Reset	201
14.4	SIM Counter	201
14.4.1	SIM Counter During Power-On Reset	202
14.4.2	SIM Counter and Reset States	202
14.5	Exception Control	202
14.5.1	Interrupts	202
14.5.1.1	Hardware Interrupts	204
14.5.1.2	Software Interrupt (SWI) Instruction	205
14.5.2	Reset	205
14.6	Low-Power Mode	205
14.6.1	Wait Mode	205
14.6.2	Stop Mode	206
14.7	SIM Registers	206
14.7.1	SIM Break Status Register	207
14.7.2	SIM Reset Status Register	207
14.7.3	SIM Break Flag Control Register	208

Section 15. Serial Peripheral Interface Module (SPI)

15.1	Introduction	209
15.2	Features	209
15.3	Pin Name Conventions	211
15.4	Functional Description	211
15.4.1	Master Mode	213
15.4.2	Slave Mode	213
15.5	Transmission Formats	214
15.5.1	Clock Phase and Polarity Controls	214
15.5.2	Transmission Format When CPHA = 0	215
15.5.3	Transmission Format When CPHA = 1	216
15.5.4	Transmission Initiation Latency	217
15.6	Error Conditions	217
15.6.1	Overflow Error	218
15.6.2	Mode Fault Error	220
15.7	Interrupts	222
15.8	Resetting the SPI	223

15.9	Queuing Transmission Data	223
15.10	Low-Power Mode	224
15.11	I/O Signals	225
15.11.1	MISO (Master In/Slave Out)	225
15.11.2	MOSI (Master Out/Slave In)	226
15.11.3	SPSCK (Serial Clock)	226
15.11.4	\overline{SS} (Slave Select)	226
15.11.5	V_{SS} (Clock Ground)	227
15.12	I/O Registers	227
15.12.1	SPI Control Register	227
15.12.2	SPI Status and Control Register	229
15.12.3	SPI Data Register	232

Section 16. Timer Interface A (TIMA)

16.1	Introduction	233
16.2	Features	233
16.3	Functional Description	237
16.3.1	TIMA Counter Prescaler	237
16.3.2	Input Capture	238
16.3.3	Output Compare	239
16.3.3.1	Unbuffered Output Compare	239
16.3.3.2	Buffered Output Compare	239
16.3.4	Pulse-Width Modulation (PWM)	240
16.3.4.1	Unbuffered PWM Signal Generation	241
16.3.4.2	Buffered PWM Signal Generation	242
16.3.4.3	PWM Initialization	242
16.4	Interrupts	244
16.5	Wait Mode	244
16.6	I/O Signals	244
16.6.1	TIMA Clock Pin (PTE3/TCLKA)	244
16.6.2	TIMA Channel I/O Pins (PTE4/TCH0A–PTE7/TCH3A)	245
16.7	I/O Registers	245
16.7.1	TIMA Status and Control Register	245
16.7.2	TIMA Counter Registers	247
16.7.3	TIMA Counter Modulo Registers	248
16.7.4	TIMA Channel Status and Control Registers	248
16.7.5	TIMA Channel Registers	252

Section 17. Timer Interface B (TIMB)

17.1	Introduction	255
17.2	Features	255
17.3	Functional Description	255
17.3.1	TIMB Counter Prescaler	258
17.3.2	Input Capture	258
17.3.3	Output Compare	259
17.3.3.1	Unbuffered Output Compare	260
17.3.3.2	Buffered Output Compare	260
17.3.4	Pulse-Width Modulation (PWM)	261
17.3.4.1	Unbuffered PWM Signal Generation	262
17.3.4.2	Buffered PWM Signal Generation	262
17.3.4.3	PWM Initialization	263
17.4	Interrupts	264
17.5	Wait Mode	264
17.6	I/O Signals	264
17.6.1	TIMB Clock Pin (PTE0/TCLKB)	264
17.6.2	TIMB Channel I/O Pins (PTE1/TCH0B–PTE2/TCH1B)	265
17.7	I/O Registers	265
17.7.1	TIMB Status and Control Register	265
17.7.2	TIMB Counter Registers	267
17.7.3	TIMB Counter Modulo Registers	268
17.7.4	TIMB Channel Status and Control Registers	268
17.7.5	TIMB Channel Registers	272

Section 18. Development Support

18.1	Introduction	273
18.2	Break Module (BRK)	273
18.2.1	Functional Description	273
18.2.1.1	Flag Protection During Break Interrupts	275
18.2.1.2	CPU During Break Interrupts	275
18.2.1.3	TIM1 and TIM2 During Break Interrupts	275
18.2.1.4	COP During Break Interrupts	275
18.2.2	Low-Power Modes	275
18.2.2.1	Wait Mode	275
18.2.2.2	Stop Mode	275
18.2.3	Break Module Registers	275
18.2.3.1	Break Status and Control Register	276
18.2.3.2	Break Address Registers	276
18.2.3.3	Break Status Register	277
18.2.3.4	Break Flag Control Register	278

18.3	Monitor ROM (MON)	278
18.3.1	Functional Description	278
18.3.1.1	Entering Monitor Mode	280
18.3.1.2	Normal Monitor Mode	280
18.3.1.3	Forced Monitor Mode	282
18.3.1.4	Data Format	282
18.3.1.5	Echoing	283
18.3.1.6	Break Signal	283
18.3.1.7	Commands	283
18.3.1.8	Baud Rate	286
18.3.2	Security	286

Section 19. Electrical Specifications

19.1	Introduction	289
19.2	Absolute Maximum Ratings	289
19.3	Functional Operating Range	290
19.4	Thermal Characteristics	290
19.5	DC Electrical Characteristics	291
19.6	FLASH Memory Characteristics	292
19.7	Control Timing	293
19.8	Serial Peripheral Interface Characteristics	294
19.9	Timer Interface Module Characteristics	297
19.10	Clock Generation Module Component Specifications	297
19.11	CGM Operating Conditions	297
19.12	CGM Acquisition/Lock Time Specifications	298
19.13	Analog-to-Digital Converter (ADC) Characteristics	299

Section 20. Ordering Information and Mechanical Specifications

20.1	Introduction	301
20.2	Order Numbers	301
20.3	64-Pin Plastic Quad Flat Pack (QFP)	302
20.4	56-Pin Shrink Dual In-Line Package (SDIP)	303

Appendix A. MC68HC908MR16

Section 1. General Description

1.1 Introduction

The MC68HC908MR32 is a member of the low-cost, high-performance M68HC08 Family of 8-bit microcontroller units (MCUs). All MCUs in the family use the enhanced M68HC08 central processor unit (CPU08) and are available with a variety of modules, memory sizes and types, and package types.

The information contained in this document pertains to the MC68HC908MR16 with the exceptions shown in [Appendix A. MC68HC908MR16](#).

1.2 Features

Features include:

- High-performance M68HC08 architecture
- Fully upward-compatible object code with M6805, M146805, and M68HC05 Families
- 8-MHz internal bus frequency
- On-chip FLASH memory with in-circuit programming capabilities of FLASH program memory:
 - MC68HC908MR32 — 32 Kbytes
 - MC68HC908MR16 — 16 Kbytes
- On-chip programming firmware for use with host personal computer
- FLASH data security⁽¹⁾
- 768 bytes of on-chip random-access memory (RAM)
- 12-bit, 6-channel center-aligned or edge-aligned pulse-width modulator (PWMMC)
- Serial peripheral interface module (SPI)
- Serial communications interface module (SCI)
- 16-bit, 4-channel timer interface module (TIMA)
- 16-bit, 2-channel timer interface module (TIMB)

1. No security feature is absolutely secure. However, Motorola's strategy is to make reading or copying the FLASH difficult for unauthorized users.

- Clock generator module (CGM)
- Low-voltage inhibit (LVI) module with software selectable trip points
- 10-bit, 10-channel analog-to-digital converter (ADC)
- System protection features:
 - Optional computer operating properly (COP) reset
 - Low-voltage detection with optional reset
 - Illegal opcode or address detection with optional reset
 - Fault detection with optional PWM disabling
- Available packages:
 - 64-pin plastic quad flat pack (QFP)
 - 56-pin shrink dual in-line package (SDIP)
- Low-power design, fully static with wait mode
- Master reset pin ($\overline{\text{RST}}$) and power-on reset (POR)
- Stop mode as an option
- Break module (BRK) supports setting the in-circuit simulator (ICS) single break point

Features of the CPU08 include:

- Enhanced M68HC05 programming model
- Extensive loop control functions
- 16 addressing modes (eight more than the M68HC05)
- 16-bit index register and stack pointer
- Memory-to-memory data transfers
- Fast 8×8 multiply instruction
- Fast 16/8 divide instruction
- Binary-coded decimal (BCD) instructions
- Optimization for controller applications
- C language support

1.3 MCU Block Diagram

Figure 1-1 shows the structure of the MC68HC908MR32.

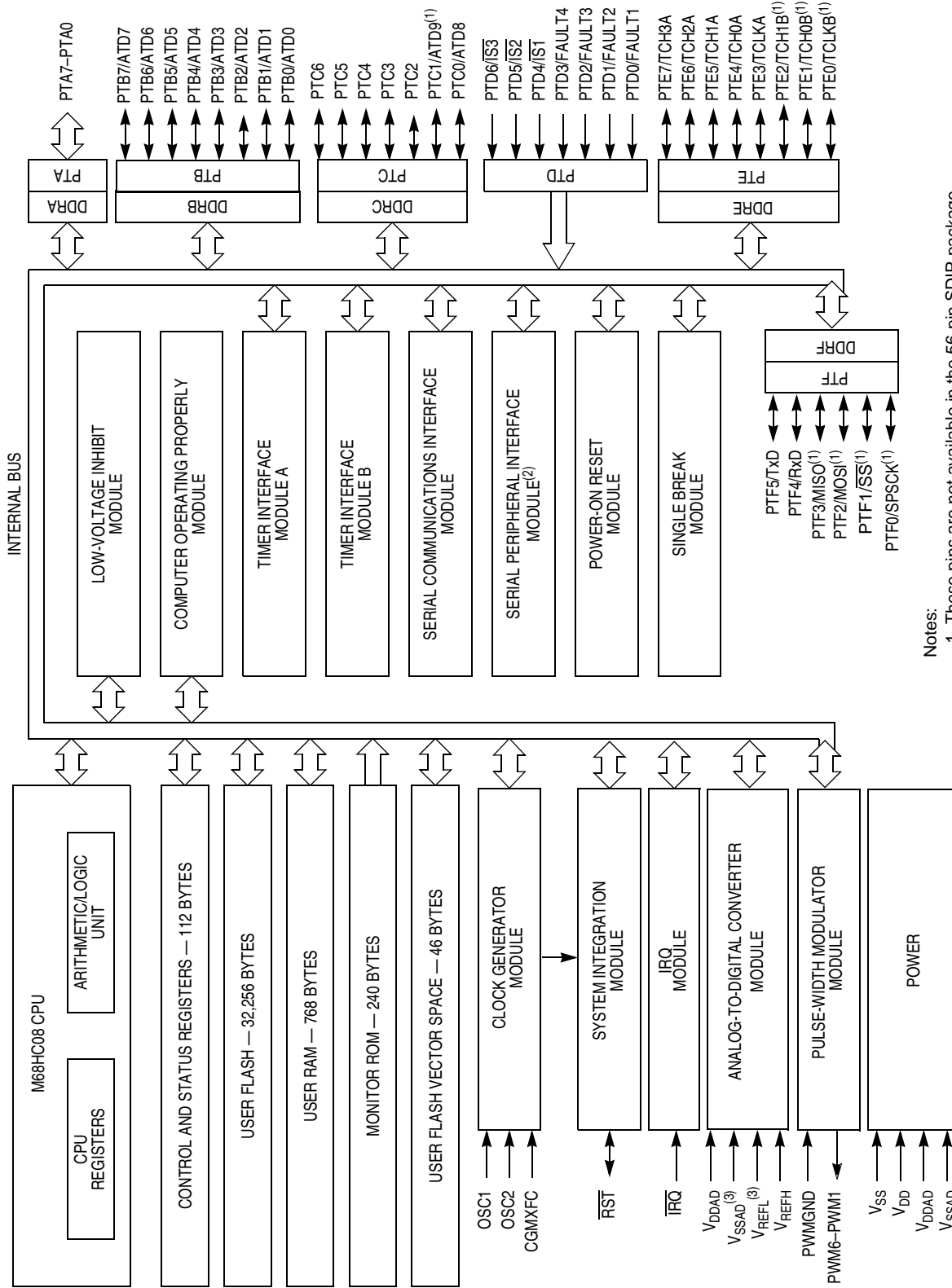

- Notes:
1. These pins are not available in the 56-pin SDIP package.
 2. This module is not available in the 56-pin SDIP package.
 3. In the 56-pin SDIP package, these pins are bonded together.

Figure 1-1. MCU Block Diagram

General Description

1.4 Pin Assignments

Figure 1-2 shows the 64-pin QFP pin assignments and Figure 1-3 shows the 56-pin SDIP pin assignments.

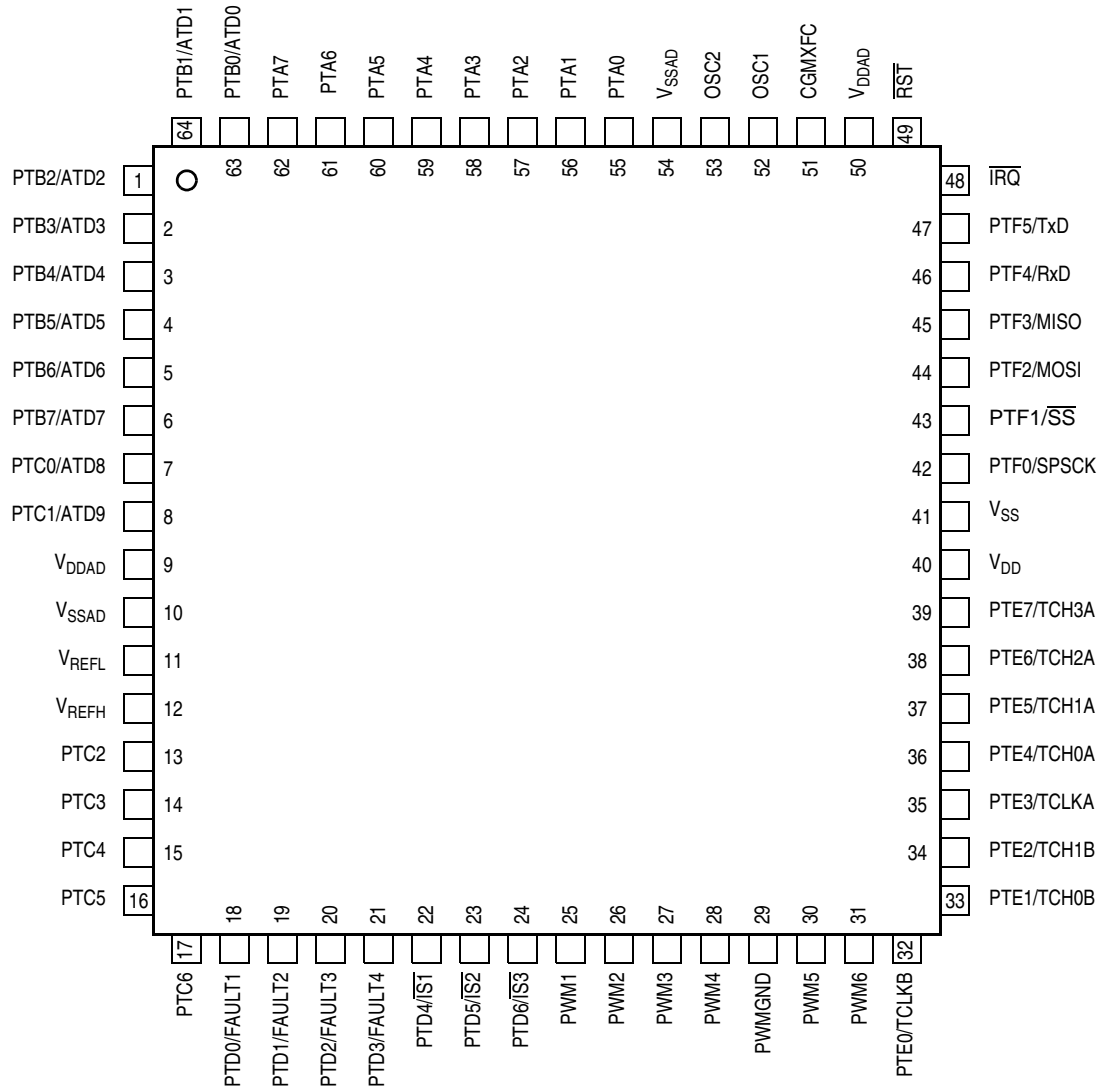
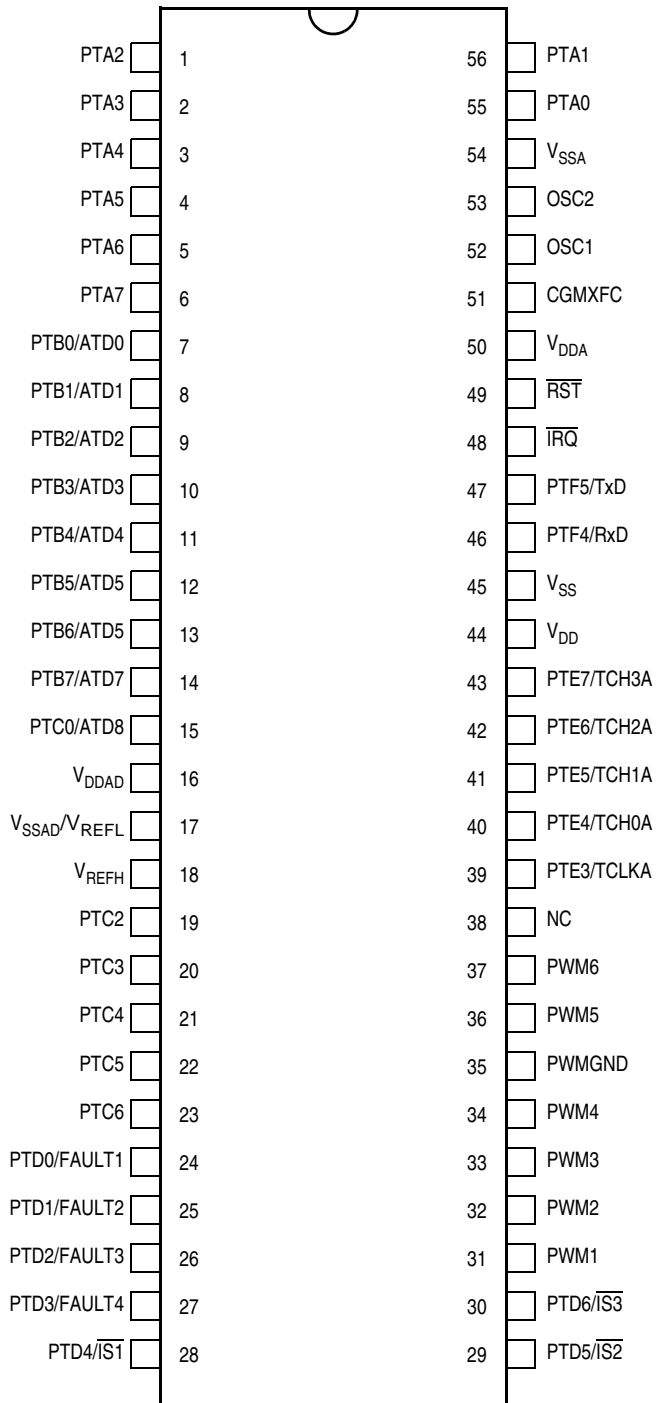

Figure 1-2. 64-Pin QFP Pin Assignments



Note:
PTC1, PTE0, PTE1, PTE2, PTF0, PTF1, PTF2, and PTF3 are removed from this package.

Figure 1-3. 56-Pin SDIP Pin Assignments

1.4.1 Power Supply Pins (V_{DD} and V_{SS})

V_{DD} and V_{SS} are the power supply and ground pins. The MCU operates from a single power supply.

Fast signal transitions on MCU pins place high, short-duration current demands on the power supply. To prevent noise problems, take special care to provide power supply bypassing at the MCU as **Figure 1-4** shows. Place the C1 bypass capacitor as close to the MCU as possible. Use a high-frequency-response ceramic capacitor for C1. C2 is an optional bulk current bypass capacitor for use in applications that require the port pins to source high-current levels.

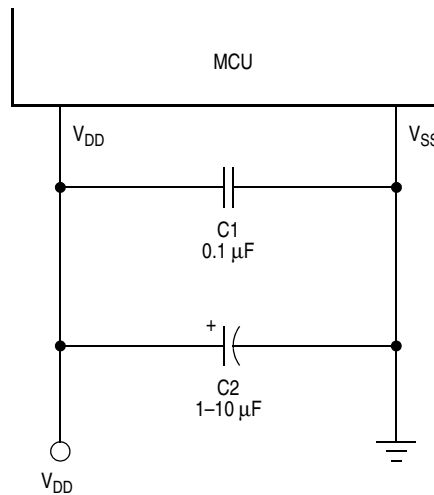

Note: Component values shown represent typical applications.

Figure 1-4. Power Supply Bypassing

1.4.2 Oscillator Pins (OSC1 and OSC2)

The OSC1 and OSC2 pins are the connections for the on-chip oscillator circuit. For more detailed information, see **Section 4. Clock Generator Module (CGM)**.

1.4.3 External Reset Pin (\overline{RST})

A logic 0 on the \overline{RST} pin forces the MCU to a known startup state. \overline{RST} is bidirectional, allowing a reset of the entire system. It is driven low when any internal reset source is asserted. See **Section 14. System Integration Module (SIM)**.

1.4.4 External Interrupt Pin (\overline{IRQ})

\overline{IRQ} is an asynchronous external interrupt pin. See **Section 8. External Interrupt (IRQ)**.

1.4.5 CGM Power Supply Pins (V_{DDA} and V_{SSAD})

V_{DDA} and V_{SSAD} are the power supply pins for the analog portion of the clock generator module (CGM). Decoupling of these pins should be per the digital supply. See [Section 4. Clock Generator Module \(CGM\)](#).

1.4.6 External Filter Capacitor Pin (CGMXFC)

CGMXFC is an external filter capacitor connection for the CGM. See [Section 4. Clock Generator Module \(CGM\)](#).

1.4.7 Analog Power Supply Pins (V_{DDAD} and V_{SSAD})

V_{DDAD} and V_{SSAD} are the power supply pins for the analog-to-digital converter. Decoupling of these pins should be per the digital supply. See [Section 3. Analog-to-Digital Converter \(ADC\)](#).

1.4.8 ADC Voltage Decoupling Capacitor Pin (V_{REFH})

V_{REFH} is the power supply for setting the reference voltage. Connect the V_{REFH} pin to the same voltage potential as V_{DDAD} . See [Section 3. Analog-to-Digital Converter \(ADC\)](#).

1.4.9 ADC Voltage Reference Low Pin (V_{REFL})

V_{REFL} is the lower reference supply for the ADC. Connect the V_{REFL} pin to the same voltage potential as V_{SSAD} . See [Section 3. Analog-to-Digital Converter \(ADC\)](#).

1.4.10 Port A Input/Output (I/O) Pins (PTA7–PTA0)

PTA7–PTA0 are general-purpose bidirectional input/output (I/O) port pins. See [Section 10. Input/Output \(I/O\) Ports \(PORTS\)](#).

1.4.11 Port B I/O Pins (PTB7/ATD7–PTB0/ATD0)

Port B is an 8-bit special function port that shares all eight pins with the analog-to-digital converter (ADC). See [Section 3. Analog-to-Digital Converter \(ADC\)](#) and [Section 10. Input/Output \(I/O\) Ports \(PORTS\)](#).

1.4.12 Port C I/O Pins (PTC6–PTC2 and PTC1/ATD9–PTC0/ATD8)

PTC6–PTC2 are general-purpose bidirectional I/O port pins (see [Section 10. Input/Output \(I/O\) Ports \(PORTS\)](#)). PTC1/ATD9–PTC0/ATD8 are special function port pins that are shared with the analog-to-digital converter (ADC). See [Section 3. Analog-to-Digital Converter \(ADC\)](#) and [Section 10. Input/Output \(I/O\) Ports \(PORTS\)](#).

1.4.13 Port D Input-Only Pins (PTD6/ $\overline{IS3}$ –PTD4/ $\overline{IS1}$ and PTD3/FAULT4–PTD0/FAULT1)

PTD6/ $\overline{IS3}$ –PTD4/ $\overline{IS1}$ are special function input-only port pins that also serve as current sensing pins for the pulse-width modulator module (PWMMC). PTD3/FAULT4–PTD0/FAULT1 are special function port pins that also serve as fault pins for the PWMMC. See [Section 12. Pulse-Width Modulator for Motor Control \(PWMMC\)](#) and [Section 10. Input/Output \(I/O\) Ports \(PORTS\)](#).

1.4.14 PWM Pins (PWM6–PWM1)

PWM6–PWM1 are dedicated pins used for the outputs of the pulse-width modulator module (PWMMC). These are high-current sink pins. See [Section 12. Pulse-Width Modulator for Motor Control \(PWMMC\)](#) and [Section 19. Electrical Specifications](#).

1.4.15 PWM Ground Pin (PWMGND)

PWMGND is the ground pin for the pulse-width modulator module (PWMMC). This dedicated ground pin is used as the ground for the six high-current PWM pins. See [Section 12. Pulse-Width Modulator for Motor Control \(PWMMC\)](#).

1.4.16 Port E I/O Pins (PTE7/TCH3A–PTE3/TCLKA and PTE2/TCH1B–PTE0/TCLKB)

Port E is an 8-bit special function port that shares its pins with the two timer interface modules (TIMA and TIMB). See [Section 16. Timer Interface A \(TIMA\)](#), [Section 17. Timer Interface B \(TIMB\)](#), and [Section 10. Input/Output \(I/O\) Ports \(PORTS\)](#).

1.4.17 Port F I/O Pins (PTF5/TxD–PTF4/RxD and PTF3/MISO–PTF0/SPSCK)

Port F is a 6-bit special function port that shares two of its pins with the serial communications interface module (SCI) and four of its pins with the serial peripheral interface module (SPI). See [Section 15. Serial Peripheral Interface Module \(SPI\)](#), [Section 13. Serial Communications Interface Module \(SCI\)](#), and [Section 10. Input/Output \(I/O\) Ports \(PORTS\)](#).

Section 2. Memory

2.1 Introduction

The central processor unit (CPU08) can address 64 Kbytes of memory space. The memory map, shown in [Figure 2-1](#), includes:

- 32 Kbytes of FLASH
- 768 bytes of random-access memory (RAM)
- 46 bytes of user-defined vectors
- 240 bytes of monitor read-only memory (ROM)

2.2 Unimplemented Memory Locations

Some addresses are unimplemented. Accessing an unimplemented address can cause an illegal address reset. In the memory map and in the input/output (I/O) register summary, unimplemented addresses are shaded.

Some I/O bits are read only; the write function is unimplemented. Writing to a read-only I/O bit has no effect on microcontroller unit (MCU) operation. In register figures, the write function of read-only bits is shaded.

Similarly, some I/O bits are write only; the read function is unimplemented. Reading of write-only I/O bits has no effect on MCU operation. In register figures, the read function of write-only bits is shaded.

2.3 Reserved Memory Locations

Some addresses are reserved. Writing to a reserved address can have unpredictable effects on MCU operation. In the memory map ([Figure 2-1](#)) and in the I/O register summary ([Figure 2-2](#)) reserved addresses are marked with the word reserved.

Some I/O bits are reserved. Writing to a reserved bit can have unpredictable effects on MCU operation. In register figures, reserved bits are marked with the letter R.

2.4 I/O Section

Addresses \$0000–\$005F, shown in **Figure 2-2**, contain most of the control, status, and data registers. Additional I/O registers have these addresses:

- \$FE00, SIM break status register (SBSR)
- \$FE01, SIM reset status register (SRSR)
- \$FE03, SIM break flag control register (SBFCR)
- \$FE07, FLASH control register (FLCR)
- \$FE0C, Break address register high (BRKH)
- \$FE0D, Break address register low (BRKL)
- \$FE0E, Break status and control register (BRKSCR)
- \$FE0F, LVI status and control register (LVISCR)
- \$FF7E, FLASH block protect register (FLBPR)
- \$FFFF, COP control register (COPCTL)

2.5 Memory Map

Figure 2-1 shows the memory map for the MC68HC908MR32 while the memory map for the MC68HC908MR16 is shown in **Appendix A. MC68HC908MR16**

\$0000 ↓ \$005F \$0060 ↓ \$035F \$0360 ↓ \$7FFF	I/O REGISTERS — 96 BYTES
\$8000 ↓ \$FDFF	RAM — 768 BYTES
\$FE00	UNIMPLEMENTED — 31,904 BYTES
\$FE01	FLASH — 32,256 BYTES
\$FE02	SIM BREAK STATUS REGISTER (SBSR)
\$FE03	SIM RESET STATUS REGISTER (SRSR)
\$FE04	RESERVED
\$FE05	SIM BREAK FLAG CONTROL REGISTER (SBFCR)
\$FE06	RESERVED
\$FE07	RESERVED
\$FE08	RESERVED
\$FE09	FLASH CONTROL REGISTER (FLCR)
\$FE0A	UNIMPLEMENTED
\$FE0B	UNIMPLEMENTED
\$FE0C	UNIMPLEMENTED
\$FE0D	SIM BREAK ADDRESS REGISTER HIGH (BRKH)
\$FE0E	SIM BREAK ADDRESS REGISTER LOW (BRKL)
\$FE0F	SIM BREAK FLAG CONTROL REGISTER (SBFCR)
\$FE10	LVI STATUS AND CONTROL REGISTER (LVISCR)
\$FEFF ↓ \$FFF0 ↓ \$FFF7D	MONITOR ROM — 240 BYTES
\$FFF7E	UNIMPLEMENTED — 126 BYTES
\$FFF7F ↓ \$FFD1	FLASH BLOCK PROTECT REGISTER (FLBPR)
\$FFD2 ↓ \$FFFF	UNIMPLEMENTED — 83 BYTES
	VECTORS — 46 BYTES

Figure 2-1. MC68HC908MR32 Memory Map

Memory

Addr.	Register Name	Bit 7	6	5	4	3	2	1	Bit 0	
\$0000	Port A Data Register (PTA) See page 113.	Read:	PTA7	PTA6	PTA5	PTA4	PTA3	PTA2	PTA1	PTA0
		Write:	PTA7	PTA6	PTA5	PTA4	PTA3	PTA2	PTA1	PTA0
		Reset:	Unaffected by reset							
\$0001	Port B Data Register (PTB) See page 115.	Read:	PTB7	PTB6	PTB5	PTB4	PTB3	PTB2	PTB1	PTB0
		Write:	PTB7	PTB6	PTB5	PTB4	PTB3	PTB2	PTB1	PTB0
		Reset:	Unaffected by reset							
\$0002	Port C Data Register (PTC) See page 117.	Read:	0	PTC6	PTC5	PTC4	PTC3	PTC2	PTC1	PTC0
		Write:	R							
		Reset:	Unaffected by reset							
\$0003	Port D Data Register (PTD) See page 119.	Read:	0	PTD6	PTD5	PTD4	PTD3	PTD2	PTD1	PTD0
		Write:	R	R	R	R	R	R	R	R
		Reset:	Unaffected by reset							
\$0004	Data Direction Register A (DDRA) See page 113.	Read:	DDRA7	DDRA6	DDRA5	DDRA4	DDRA3	DDRA2	DDRA1	DDRA0
		Write:	DDRA7	DDRA6	DDRA5	DDRA4	DDRA3	DDRA2	DDRA1	DDRA0
		Reset:	0	0	0	0	0	0	0	0
\$0005	Data Direction Register B (DDRB) See page 115.	Read:	DDRB7	DDRB6	DDRB5	DDRB4	DDRB3	DDRB2	DDRB1	DDRB0
		Write:	DDRB7	DDRB6	DDRB5	DDRB4	DDRB3	DDRB2	DDRB1	DDRB0
		Reset:	0	0	0	0	0	0	0	0
\$0006	Data Direction Register C (DDRC) See page 117.	Read:	0	DDRC6	DDRC5	DDRC4	DDRC3	DDRC2	DDRC1	DDRC0
		Write:	R							
		Reset:	0	0	0	0	0	0	0	0
\$0007	Unimplemented									
\$0008	Port E Data Register (PTE) See page 120.	Read:	PTE7	PTE6	PTE5	PTE4	PTE3	PTE2	PTE1	PTE0
		Write:	PTE7	PTE6	PTE5	PTE4	PTE3	PTE2	PTE1	PTE0
		Reset:	Unaffected by reset							
\$0009	Port F Data Register (PTF) See page 122.	Read:	0	0	PTF5	PTF4	PTF3	PTF2	PTF1	PTF0
		Write:	R	R						
		Reset:	Unaffected by reset							
\$000A	Unimplemented									
\$000B	Unimplemented									
\$000C	Data Direction Register E (DDRE) See page 120.	Read:	DDRE7	DDRE6	DDRE5	DDRE4	DDRE3	DDRE2	DDRE1	DDRE0
		Write:	DDRE7	DDRE6	DDRE5	DDRE4	DDRE3	DDRE2	DDRE1	DDRE0
		Reset:	0	0	0	0	0	0	0	0

U = Unaffected

X = Indeterminate

R

= Reserved

Bold

= Buffered

= Unimplemented

Figure 2-2. Control, Status, and Data Registers Summary (Sheet 1 of 8)

Addr.	Register Name	Bit 7	6	5	4	3	2	1	Bit 0	
\$000D	Data Direction Register F (DDRF) See page 122.	Read:	0	0	DDRF5	DDRF4	DDRF3	DDRF2	DDRF1	DDRF0
		Write:	R	R						
		Reset:	0 0 0 0 0 0 0							
\$000E	TIMA Status/Control Register (TASC) See page 245.	Read:	TOF	TOIE	TSTOP	0	0	PS2	PS1	PS0
		Write:	0			TRST	R			
		Reset:	0 0 1 0 0 0 0 0							
\$000F	TIMA Counter Register High (TACNTH) See page 247.	Read:	Bit 15	Bit 14	Bit 13	Bit 12	Bit 11	Bit 10	Bit 9	Bit 8
		Write:	R	R	R	R	R	R	R	R
		Reset:	0 0 0 0 0 0 0 0							
\$0010	TIMA Counter Register Low (TACNTL) See page 247.	Read:	Bit 7	Bit 6	Bit 5	Bit 4	Bit 3	Bit 2	Bit 1	Bit 0
		Write:	R	R	R	R	R	R	R	R
		Reset:	0 0 0 0 0 0 0 0							
\$0011	TIMA Counter Modulo Register High (TAMODH) See page 248.	Read:	Bit 15	14	13	12	11	10	9	Bit 8
		Write:	R	R	R	R	R	R	R	R
		Reset:	1 1 1 1 1 1 1 1							
\$0012	TIMA Counter Modulo Register Low (TAMODL) See page 248.	Read:	Bit 7	Bit 6	Bit 5	Bit 4	Bit 3	Bit 2	Bit 1	Bit 0
		Write:	R	R	R	R	R	R	R	R
		Reset:	1 1 1 1 1 1 1 1							
\$0013	TIMA Channel 0 Status/Control Register (TASC0) See page 249.	Read:	CH0F	CH0IE	MS0B	MS0A	ELS0B	ELS0A	TOV0	CH0MAX
		Write:	0							
		Reset:	0 0 0 0 0 0 0 0							
\$0014	TIMA Channel 0 Register High (TACH0H) See page 252.	Read:	Bit 15	Bit 14	Bit 13	Bit 12	Bit 11	Bit 10	Bit 9	Bit 8
		Write:	R	R	R	R	R	R	R	R
		Reset:	Indeterminate after reset							
\$0015	TIMA Channel 0 Register Low (TACH0L) See page 252.	Read:	Bit 7	Bit 6	Bit 5	Bit 4	Bit 3	Bit 2	Bit 1	Bit 0
		Write:	R	R	R	R	R	R	R	R
		Reset:	Indeterminate after reset							
\$0016	TIMA Channel 1 Status/Control Register (TASC1) See page 252.	Read:	CH1F	CH1IE	0	MS1A	ELS1B	ELS1A	TOV1	CH1MAX
		Write:	0		R					
		Reset:	0 0 0 0 0 0 0 0							
\$0017	TIMA Channel 1 Register High (TACH1H) See page 252.	Read:	Bit 15	Bit 14	Bit 13	Bit 12	Bit 11	Bit 10	Bit 9	Bit 8
		Write:	R	R	R	R	R	R	R	R
		Reset:	Indeterminate after reset							
\$0018	TIMA Channel 1 Register Low (TACH1L) See page 252.	Read:	Bit 7	Bit 6	Bit 5	Bit 4	Bit 3	Bit 2	Bit 1	Bit 0
		Write:	R	R	R	R	R	R	R	R
		Reset:	Indeterminate after reset							

U = Unaffected X = Indeterminate R = Reserved = Buffered = Unimplemented

Figure 2-2. Control, Status, and Data Registers Summary (Sheet 2 of 8)

Memory

Addr.	Register Name	Bit 7	6	5	4	3	2	1	Bit 0	
\$0019	TIMA Channel 2 Status/Control Register (TASC2) See page 249.	Read:	CH2F	CH2IE	MS2B	MS2A	ELS2B	ELS2A	TOV2	CH2MAX
		Write:	0							
		Reset:	0	0	0	0	0	0	0	0
\$001A	TIMA Channel 2 Register High (TACH2H) See page 252.	Read:	Bit 15	Bit 14	Bit 13	Bit 12	Bit 11	Bit 10	Bit 9	Bit 8
		Write:	Bit 15	Bit 14	Bit 13	Bit 12	Bit 11	Bit 10	Bit 9	Bit 8
		Reset:	Indeterminate after reset							
\$001B	TIMA Channel 2 Register Low (TACH2L) See page 252.	Read:	Bit 7	Bit 6	Bit 5	Bit 4	Bit 3	Bit 2	Bit 1	Bit 0
		Write:	Bit 7	Bit 6	Bit 5	Bit 4	Bit 3	Bit 2	Bit 1	Bit 0
		Reset:	Indeterminate after reset							
\$001C	TIMA Channel 3 Status/Control Register (TASC3) See page 249.	Read:	CH3F	CH3IE	0	MS3A	ELS3B	ELS3A	TOV3	CH3MAX
		Write:	0		R					
		Reset:	0	0	0	0	0	0	0	0
\$001D	TIMA Channel 3 Register High (TACH3H) See page 252.	Read:	Bit 15	Bit 14	Bit 13	Bit 12	Bit 11	Bit 10	Bit 9	Bit 8
		Write:	Bit 15	Bit 14	Bit 13	Bit 12	Bit 11	Bit 10	Bit 9	Bit 8
		Reset:	Indeterminate after reset							
\$001E	TIMA Channel 3 Register Low (TACH3L) See page 252.	Read:	Bit 7	Bit 6	Bit 5	Bit 4	Bit 3	Bit 2	Bit 1	Bit 0
		Write:	Bit 7	Bit 6	Bit 5	Bit 4	Bit 3	Bit 2	Bit 1	Bit 0
		Reset:	Indeterminate after reset							
\$001F	Configuration Register (CONFIG) See page 80.	Read:	EDGE	BOTNEG	TOPNEG	INDEP	LVIRST	LVIPWR	STOPE	COPD
		Write:	EDGE	BOTNEG	TOPNEG	INDEP	LVIRST	LVIPWR	STOPE	COPD
		Reset:	0	0	0	0	1	1	0	0
\$0020	PWM Control Register 1 (PCTL1) See page 158.	Read:	DISX	DISY	PWMINT	PWMF	ISENS1	ISENS0	LDOK	PWMEN
		Write:	DISX	DISY	PWMINT	PWMF	ISENS1	ISENS0	LDOK	PWMEN
		Reset:	0	0	0	0	0	0	0	0
\$0021	PWM Control Register 2 (PCTL2) See page 160.	Read:	LDFQ1	LDFQ0	0	IPOL1	IPOL2	IPOL3	PRSC1	PRSC0
		Write:	LDFQ1	LDFQ0						
		Reset:	0	0	0	0	0	0	0	0
\$0022	Fault Control Register (FCR) See page 162.	Read:	FINT4	FMODE4	FINT3	FMODE3	FINT2	FMODE2	FINT1	FMODE1
		Write:	FINT4	FMODE4	FINT3	FMODE3	FINT2	FMODE2	FINT1	FMODE1
		Reset:	0	0	0	0	0	0	0	0
\$0023	Fault Status Register (FSR) See page 164.	Read:	FPIN4	FFLAG4	FPIN3	FFLAG3	FPIN2	FFLAG2	FPIN1	FFLAG1
		Write:								
		Reset:	U	0	U	0	U	0	U	0
\$0024	Fault Acknowledge Register (FTACK) See page 165.	Read:	0	0	DT6	DT5	DT4	DT3	DT2	DT1
		Write:		FTACK4		FTACK3		FTACK2		FTACK1
		Reset:	0	0	0	0	0	0	0	0

U = Unaffected X = Indeterminate R = Reserved Bold = Buffered = Unimplemented

Figure 2-2. Control, Status, and Data Registers Summary (Sheet 3 of 8)

Addr.	Register Name	Bit 7	6	5	4	3	2	1	Bit 0		
\$0025	PWM Output Control Register (PWMOUT) See page 166.	Read:	0	OUTCTL	OUT6	OUT5	OUT4	OUT3	OUT2	OUT1	
		Write:									
		Reset:	0	0	0	0	0	0	0	0	
\$0026	PWM Counter Register High (PCNTH) See page 156.	Read:	0	0	0	0	Bit 11	Bit 10	Bit 9	Bit 8	
		Write:									
		Reset:	0	0	0	0	0	0	0	0	
\$0027	PWM Counter Register Low (PCNTL) See page 156.	Read:	Bit 7	Bit 6	Bit 5	Bit 4	Bit 3	Bit 2	Bit 1	Bit 0	
		Write:									
		Reset:	0	0	0	0	0	0	0	0	
\$0028	PWM Counter Modulo Register High (PMODH) See page 156.	Read:	0	0	0	0	Bit 11	Bit 10	Bit 9	Bit 8	
		Write:									
		Reset:	0	0	0	0	X	X	X	X	
\$0029	PWM Counter Modulo Register Low (PMDL) See page 156.	Read:	Bit 7	Bit 6	Bit 5	Bit 4	Bit 3	Bit 2	Bit 1	Bit 0	
		Write:									
		Reset:	X	X	X	X	X	X	X	X	
\$002A	PWM 1 Value Register High (PVAL1H) See page 157.	Read:	Bit 15	Bit 14	Bit 13	Bit 12	Bit 11	Bit 10	Bit 9	Bit 8	
		Write:									
		Reset:	0	0	0	0	0	0	0	0	
\$002B	PWM 1 Value Register Low (PVAL1L) See page 157.	Read:	Bit 7	Bit 6	Bit 5	Bit 4	Bit 3	Bit 2	Bit 1	Bit 0	
		Write:									
		Reset:	0	0	0	0	0	0	0	0	
\$002C	PWM 2 Value Register High (PVAL2H) See page 157.	Read:	Bit 15	Bit 14	Bit 13	Bit 12	Bit 11	Bit 10	Bit 9	Bit 8	
		Write:									
		Reset:	0	0	0	0	0	0	0	0	
\$002D	PWM 2 Value Register Low (PVAL2L) See page 157.	Read:	Bit 7	Bit 6	Bit 5	Bit 4	Bit 3	Bit 2	Bit 1	Bit 0	
		Write:									
		Reset:	0	0	0	0	0	0	0	0	
\$002E	PWM 3 Value Register High (PVAL3H) See page 157.	Read:	Bit 15	Bit 14	Bit 13	Bit 12	Bit 11	Bit 10	Bit 9	Bit 8	
		Write:									
		Reset:	0	0	0	0	0	0	0	0	
\$002F	PWM 3 Value Register Low (PVAL3L) See page 157.	Read:	Bit 7	Bit 6	Bit 5	Bit 4	Bit 3	Bit 2	Bit 1	Bit 0	
		Write:									
		Reset:	0	0	0	0	0	0	0	0	
\$0030	PWM 4 Value Register High (PVAL4H) See page 157.	Read:	Bit 15	Bit 14	Bit 13	Bit 12	Bit 11	Bit 10	Bit 9	Bit 8	
		Write:									
		Reset:	0	0	0	0	0	0	0	0	

U = Unaffected X = Indeterminate

R = Reserved
 = Buffered
 = Unimplemented

Figure 2-2. Control, Status, and Data Registers Summary (Sheet 4 of 8)

Memory

Addr.	Register Name	Bit 7	6	5	4	3	2	1	Bit 0		
\$0031	PWM 4 Value Register Low (PVAL4L) See page 157.	Read:									
		Write:	Bit 7	Bit 6	Bit 5	Bit 4	Bit 3	Bit 2	Bit 1	Bit 0	
		Reset:	0	0	0	0	0	0	0	0	
\$0032	PWM 5 Value Register High (PMVAL5H) See page 157.	Read:									
		Write:	Bit 15	Bit 14	Bit 13	Bit 12	Bit 11	Bit 10	Bit 9	Bit 8	
		Reset:	0	0	0	0	0	0	0	0	
\$0033	PWM 5 Value Register Low (PVAL5L) See page 157.	Read:									
		Write:	Bit 7	Bit 6	Bit 5	Bit 4	Bit 3	Bit 2	Bit 1	Bit 0	
		Reset:	0	0	0	0	0	0	0	0	
\$0034	PWM 6 Value Register High (PVAL6H) See page 157.	Read:									
		Write:	Bit 15	Bit 14	Bit 13	Bit 12	Bit 11	Bit 10	Bit 9	Bit 8	
		Reset:	0	0	0	0	0	0	0	0	
\$0035	PWM 6 Value Register Low (PMVAL6L) See page 157.	Read:									
		Write:	Bit 7	Bit 6	Bit 5	Bit 4	Bit 3	Bit 2	Bit 1	Bit 0	
		Reset:	0	0	0	0	0	0	0	0	
\$0036	Dead-Time Write-Once Register (DEADTM) See page 162.	Read:									
		Write:	Bit 7	Bit 6	Bit 5	Bit 4	Bit 3	Bit 2	Bit 1	Bit 0	
		Reset:	1	1	1	1	1	1	1	1	
\$0037	PWM Disable Mapping Write-Once Register (DISMAP) See page 149.	Read:									
		Write:	Bit 7	Bit 6	Bit 5	Bit 4	Bit 3	Bit 2	Bit 1	Bit 0	
		Reset:	1	1	1	1	1	1	1	1	
\$0038	SCI Control Register 1 (SCC1) See page 183.	Read:	LOOPS	ENSCI	TXINV	M	WAKE	ILTY	PEN	PTY	
		Write:									
		Reset:	0	0	0	0	0	0	0	0	0
\$0039	SCI Control Register 2 (SCC2) See page 185.	Read:	SCTIE	TCIE	SCRIE	ILIE	TE	RE	RWU	SBK	
		Write:									
		Reset:	0	0	0	0	0	0	0	0	0
\$003A	SCI Control Register 3 (SCC3) See page 187.	Read:	R8	T8	0	0	ORIE	NEIE	FEIE	PEIE	
		Write:	R		R						
		Reset:	U	U	0	0	0	0	0	0	0
\$003B	SCI Status Register 1 (SCS1) See page 188.	Read:	SCTE	TC	SCRF	IDLE	OR	NF	FE	PE	
		Write:	R	R	R	R	R	R	R	R	
		Reset:	1	1	0	0	0	0	0	0	0
\$003C	SCI Status Register 2 (SCS2) See page 191.	Read:	0	0	0	0	0	0	BKF	RPF	
		Write:	R	R	R	R	R	R	R	R	
		Reset:	0	0	0	0	0	0	0	0	0

U = Unaffected X = Indeterminate

R

 = Reserved

 = Buffered

 = Unimplemented

Figure 2-2. Control, Status, and Data Registers Summary (Sheet 5 of 8)

Addr.	Register Name	Bit 7	6	5	4	3	2	1	Bit 0	
\$003D	SCI Data Register (SCDR) See page 192.	Read:	R7	R6	R5	R4	R3	R2	R1	R0
		Write:	T7	T6	T5	T4	T3	T2	T1	T0
		Reset:	Unaffected by reset							
\$003E	SCI Baud Rate Register (SCBR) See page 192.	Read:	0	0	SCP1	SCP0	0	SCR2	SCR1	SCR0
		Write:	R	R			R			
		Reset:	0	0	0	0	0	0	0	0
\$003F	IRQ Status/Control Register (ISCR) See page 105.	Read:	0	0	0	0	IRQF	0	IMASK1	MODE1
		Write:	R	R	R	R		ACK1		
		Reset:	0	0	0	0	0	0	0	0
\$0040	ADC Status and Control Register (ADSCR) See page 54.	Read:	COCO	AIEN	ADCO	ADCH4	ADCH3	ADCH2	ADCH1	ADCH0
		Write:	R							
		Reset:	0	0	0	1	1	1	1	1
\$0041	ADC Data Register High Right Justified Mode (ADRH) See page 56.	Read:	0	0	0	0	0	0	AD9	AD8
		Write:	R	R	R	R	R	R	R	R
		Reset:	Unaffected by reset							
\$0042	ADC Data Register Low Right Justified Mode (ADRL) See page 56.	Read:	AD7	AD6	AD5	AD4	AD3	AD2	AD1	AD0
		Write:	R	R	R	R	R	R	R	R
		Reset:	Unaffected by reset							
\$0043	ADC Clock Register (ADCLK) See page 57.	Read:	ADIV2	ADIV1	ADIV0	ADICLK	MODE1	MODE0	0	0
		Write:							R	
		Reset:	0	0	0	0	0	1	0	0
\$0044	SPI Control Register (SPCR) See page 228.	Read:	SPRIE	R	SPMSTR	CPOL	CPHA	SPWOM	SPE	SPTIE
		Write:	R	R	R	R	R	R	R	R
		Reset:	0	0	1	0	1	0	0	0
\$0045	SPI Status and Control Register (SPSCR) See page 229.	Read:	SPRF	ERRIE	OVRF	MODF	SPTIE	MODFEN	SPR1	SPR0
		Write:	R		R	R	R			
		Reset:	0	0	0	0	1	0	0	0
\$0046	SPI Data Register (SPDR) See page 232.	Read:	R7	R6	R5	R4	R3	R2	R1	R0
		Write:	T7	T6	T5	T4	T3	T2	T1	T0
		Reset:	Unaffected by reset							
\$0047 ↓ \$0050	Unimplemented									
\$0051	TIMB Status/Control Register (TBSC) See page 265.	Read:	TOF	TOIE	TSTOP	0	0	PS2	PS1	PS0
		Write:	0			TRST	R			
		Reset:	0	0	1	0	0	0	0	0

U = Unaffected X = Indeterminate R = Reserved = Buffered = Unimplemented

Figure 2-2. Control, Status, and Data Registers Summary (Sheet 6 of 8)

Memory

Addr.	Register Name	Bit 7	6	5	4	3	2	1	Bit 0	
\$0052	TIMB Counter Register High (TBCNTH) See page 267.	Read:	Bit 15	Bit 14	Bit 13	Bit 12	Bit 11	Bit 10	Bit 9	Bit 8
		Write:	R	R	R	R	R	R	R	R
		Reset:	0	0	0	0	0	0	0	0
\$0053	TIMB Counter Register Low (TBCNTL) See page 267.	Read:	Bit 7	Bit 6	Bit 5	Bit 4	Bit 3	Bit 2	Bit 1	Bit 0
		Write:	R	R	R	R	R	R	R	R
		Reset:	0	0	0	0	0	0	0	0
\$0054	TIMB Counter Modulo Register High (TBMODH) See page 268.	Read:	Bit 15	Bit 14	Bit 13	Bit 12	Bit 11	Bit 10	Bit 9	Bit 8
		Write:	R	R	R	R	R	R	R	R
		Reset:	1	1	1	1	1	1	1	1
\$0055	TIMB Counter Modulo Register Low (TBMODL) See page 268.	Read:	Bit 7	Bit 6	Bit 5	Bit 4	Bit 3	Bit 2	Bit 1	Bit 0
		Write:	R	R	R	R	R	R	R	R
		Reset:	1	1	1	1	1	1	1	1
\$0056	TIMB Channel 0 Status/Control Register (TBSC0) See page 269.	Read:	CH0F	CH0IE	MS0B	MS0A	ELS0B	ELS0A	TOV0	CH0MAX
		Write:	0							
		Reset:	0	0	0	0	0	0	0	0
\$0057	TIMB Channel 0 Register High (TBCH0H) See page 272.	Read:	Bit 15	Bit 14	Bit 13	Bit 12	Bit 11	Bit 10	Bit 9	Bit 8
		Write:	R	R	R	R	R	R	R	R
		Reset:	Indeterminate after reset							
\$0058	TIMB Channel 0 Register Low (TBCH0L) See page 272.	Read:	Bit 7	Bit 6	Bit 5	Bit 4	Bit 3	Bit 2	Bit 1	Bit 0
		Write:	R	R	R	R	R	R	R	R
		Reset:	Indeterminate after reset							
\$0059	TIMB Channel 1 Status/Control Register (TBSC1) See page 269.	Read:	CH1F	CH1IE	0	MS1A	ELS1B	ELS1A	TOV1	CH1MAX
		Write:	0		R					
		Reset:	0	0	0	0	0	0	0	0
\$005A	TIMB Channel 1 Register High (TBCH1H) See page 272.	Read:	Bit 15	Bit 14	Bit 13	Bit 12	Bit 11	Bit 10	Bit 9	Bit 8
		Write:	R	R	R	R	R	R	R	R
		Reset:	Indeterminate after reset							
\$005B	TIMB Channel 1 Register Low (TBCH1L) See page 272.	Read:	Bit 7	Bit 6	Bit 5	Bit 4	Bit 3	Bit 2	Bit 1	Bit 0
		Write:	R	R	R	R	R	R	R	R
		Reset:	Indeterminate after reset							
\$005C	PLL Control Register (PCTL) See page 69.	Read:	PLLIE	PLLIF	PLLON	BCS	1	1	1	1
		Write:		R			R	R	R	R
		Reset:	0	0	1	0	1	1	1	1
\$005D	PLL Bandwidth Control Register (PBWC) See page 71.	Read:	AUTO	LOCK	ACQ	XLD	0	0	0	0
		Write:		R			R	R	R	R
		Reset:	0	0	0	0	0	0	0	0

U = Unaffected X = Indeterminate

R = Reserved
 = Buffered
 = Unimplemented

Figure 2-2. Control, Status, and Data Registers Summary (Sheet 7 of 8)

Addr.	Register Name	Bit 7	6	5	4	3	2	1	Bit 0	
\$005E	PLL Programming Register (PPG) See page 72.	Read:	MUL7	MUL6	MUL5	MUL4	VRS7	VRS6	VRS5	VRS4
		Write:								
		Reset:	0	1	1	0	0	1	1	0
\$005F	Unimplemented									
\$FE00	SIM Break Status Register (SBSR) See page 207.	Read:	R	R	R	R	R	R	BW	R
		Write:								
		Reset:	0							
\$FE01	SIM Reset Status Register (SRSR) See page 207.	Read:	POR	PIN	COP	ILOP	ILAD	MENRST	LVI	0
		Write:	R	R	R	R	R	R	R	R
		Reset:	1	0	0	0	0	0	0	0
\$FE03	SIM Break Flag Control Register (SBFCR) See page 208.	Read:	BCFE	R	R	R	R	R	R	R
		Write:								
		Reset:	0							
\$FE08	FLASH Control Register (FLCR) See page 41.	Read:	0	0	0	0	HVEN	MASS	ERASE	PGM
		Write:								
		Reset:	0	0	0	0	0	0	0	0
\$FE0C	Break Address Register High (BRKH) See page 276.	Read:	Bit 15	14	13	12	11	10	9	Bit 8
		Write:								
		Reset:	0	0	0	0	0	0	0	0
\$FE0D	Break Address Register Low (BRKL) See page 276.	Read:	Bit 7	6	5	4	3	2	1	Bit 0
		Write:								
		Reset:	0	0	0	0	0	0	0	0
\$FE0E	Break Status and Control Register (BRKSCR) See page 276.	Read:	BRKE	BRKA	0	0	0	0	0	0
		Write:								
		Reset:	0	0	0	0	0	0	0	0
\$FE0F	LVI Status and Control Register (LVISCR) See page 109.	Read:	LVIOUT	0	TRPSEL	0	0	0	0	0
		Write:	R	R		R	R	R	R	R
		Reset:	0	0	0	0	0	0	0	0
\$FF7E	FLASH Block Protect Register (FLBPR) See page 45.	Read:	BPR7	BPR6	BPR5	BPR4	BPR3	BPR2	BPR1	BPR0
		Write:								
		Reset:	0	0	0	0	0	0	0	0
\$FFFF	COP Control Register (COPCTL) See page 85.	Read:	Low byte of reset vector							
		Write:	Clear COP counter							
		Reset:	Unaffected by reset							

U = Unaffected X = Indeterminate R = Reserved = Buffered = Unimplemented

Figure 2-2. Control, Status, and Data Registers Summary (Sheet 8 of 8)

Table 2-1 is a list of vector locations.

Table 2-1. Vector Addresses

Address	Vector
\$FFD2	SCI transmit vector (high)
\$FFD3	SCI transmit vector (low)
\$FFD4	SCI receive vector (high)
\$FFD5	SCI receive vector (low)
\$FFD6	SCI error vector (high)
\$FFD7	SCI error vector (low)
\$FFD8	SPI transmit vector (high) ⁽¹⁾
\$FFD9	SPI transmit vector (low) ⁽¹⁾
\$FFDA	SPI receive vector (high) ⁽¹⁾
\$FFDB	SPI receive vector (low) ⁽¹⁾
\$FFDC	A/D vector (high)
\$FFDD	A/D vector (low)
\$FFDE	TIMB overflow vector (high)
\$FFDF	TIMB overflow vector (low)
\$FFE0	TIMB channel 1 vector (high)
\$FFE1	TIMB channel 1 vector (low)
\$FFE2	TIMB channel 0 vector (high)
\$FFE3	TIMB channel 0 vector (low)
\$FFE4	TIMA overflow vector (high)
\$FFE5	TIMA overflow vector (low)
\$FFE6	TIMA channel 3 vector (high)
\$FFE7	TIMA channel 3 vector (low)
\$FFE8	TIMA channel 2 vector (high)
\$FFE9	TIMA channel 2 vector (low)
\$FFEa	TIMA channel 1 vector (high)
\$FFEB	TIMA channel 1 vector (low)
\$FFEC	TIMA channel 0 vector (high)
\$FFED	TIMA channel 0 vector (low)

Priority ↑ Low

1. The SPI module is not available in the 56-pin SDIP package.

Table 2-1. Vector Addresses (Continued)

Address	Vector
\$FFEE	PWMMC vector (high)
\$FFEF	PWMMC vector (low)
\$FFF0	FAULT 4 (high)
\$FFF1	FAULT 4 (low)
\$FFF2	FAULT 3 (high)
\$FFF3	FAULT 3 (low)
\$FFF4	FAULT 2 (high)
\$FFF5	FAULT 2 (low)
\$FFF6	FAULT 1 (high)
\$FFF7	FAULT 1 (low)
\$FFF8	PLL vector (high)
\$FFF9	PLL vector (low)
\$FFFA	IRQ vector (high)
\$FFFB	IRQ vector (low)
\$FFFC	SWI vector (high)
\$FFFD	SWI vector (low)
\$FFFE	Reset vector (high)
\$FFFF	Reset vector (low)

Priority
↑
↓
High

2.6 Monitor ROM

The 240 bytes at addresses \$FE10–\$FEFF are reserved ROM addresses that contain the instructions for the monitor functions. See [18.3 Monitor ROM \(MON\)](#).

2.7 Random-Access Memory (RAM)

Addresses \$0060–\$035F are RAM locations. The location of the stack RAM is programmable. The 16-bit stack pointer allows the stack to be anywhere in the 64-Kbyte memory space.

NOTE: For correct operation, the stack pointer must point only to RAM locations.

Within page zero are 160 bytes of RAM. Because the location of the stack RAM is programmable, all page zero RAM locations can be used for input/output (I/O) control and user data or code. When the stack pointer is moved from its reset location at \$00FF, direct addressing mode instructions can access efficiently all page zero RAM locations. Page zero RAM, therefore, provides ideal locations for frequently accessed global variables.

Before processing an interrupt, the central processor unit (CPU) uses five bytes of the stack to save the contents of the CPU registers.

NOTE: For M68HC05 and M1468HC05 compatibility, the H register is not stacked.

During a subroutine call, the CPU uses two bytes of the stack to store the return address. The stack pointer decrements during pushes and increments during pulls.

NOTE: Be careful when using nested subroutines. The CPU may overwrite data in the RAM during a subroutine or during the interrupt stacking operation.

2.8 FLASH Memory (FLASH)

The FLASH memory is an array of 32,256 bytes with an additional 46 bytes of user vectors and one byte of block protection.

NOTE: An erased bit reads as a 1 and a programmed bit reads as a 0.

Program and erase operations are facilitated through control bits in a memory mapped register. Details for these operations appear later in this section.

Memory in the FLASH array is organized into two rows per page. The page size is 128 bytes per page. The minimum erase page size is 128 bytes. Programming is performed on a row basis, 64 bytes at a time.

The address ranges for the user memory and vectors are:

- \$8000–\$FDFF, user memory
- \$FF7E, block protect register (FLBPR)
- \$FE08, FLASH control register (FLCR)
- \$FFD2–\$FFFF, reserved for user-defined interrupt and reset vectors

Programming tools are available from Motorola. Contact a local Motorola representative for more information.

NOTE: A security feature prevents viewing of the FLASH contents.⁽¹⁾

1. No security feature is absolutely secure. However, Motorola's strategy is to make reading or copying the FLASH difficult for unauthorized users.

2.8.1 FLASH Control Register

The FLASH control register (FLCR) controls FLASH program and erase operations.

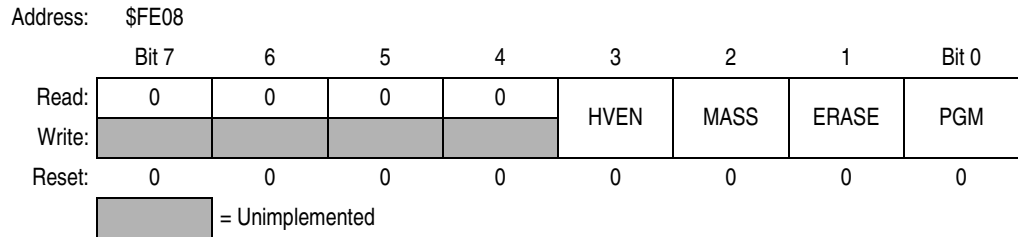

Figure 2-3. FLASH Control Register (FLCR)

HVEN — High-Voltage Enable Bit

This read/write bit enables the charge pump to drive high voltages for program and erase operations in the array. HVEN can only be set if either PGM = 1 or ERASE = 1 and the proper sequence for program or erase is followed.

- 1 = High voltage enabled to array and charge pump on
- 0 = High voltage disabled to array and charge pump off

MASS — Mass Erase Control Bit

Setting this read/write bit configures the 32-Kbyte FLASH array for mass erase operation. Mass erase is disabled if any FLASH block is protected

- 1 = MASS erase operation selected
- 0 = MASS erase operation unselected

ERASE — Erase Control Bit

This read/write bit configures the memory for erase operation. ERASE is interlocked with the PGM bit such that both bits cannot be equal to 1 or set to 1 at the same time.

- 1 = Erase operation selected
- 0 = Erase operation unselected

PGM — Program Control Bit

This read/write bit configures the memory for program operation. PGM is interlocked with the ERASE bit such that both bits cannot be equal to 1 or set to 1 at the same time.

- 1 = Program operation selected
- 0 = Program operation unselected

2.8.2 FLASH Page Erase Operation

Use this step-by-step procedure to erase a page (128 bytes) of FLASH memory.

1. Set the ERASE bit and clear the MASS bit in the FLASH control register.
2. Read the FLASH block protect register.
3. Write any data to any FLASH location within the address range of the block to be erased.
4. Wait for a time, t_{NVS} (minimum 10 μ s).
5. Set the HVEN bit.
6. Wait for a time, t_{Erase} (minimum 1 ms or 4 ms).
7. Clear the ERASE bit.
8. Wait for a time, t_{NVH} (minimum 5 μ s).
9. Clear the HVEN bit.
10. After time, t_{RCV} (typical 1 μ s), the memory can be accessed in read mode again.

NOTE: Programming and erasing of FLASH locations cannot be performed by code being executed from the FLASH memory. While these operations must be performed in the order shown, other unrelated operations may occur between the steps.

In applications that require more than 1000 program/erase cycles, use the 4 ms page erase specification to get improved long-term reliability. Any application can use this 4 ms page erase specification. However, in applications where a FLASH location will be erased and reprogrammed less than 1000 times, and speed is important, use the 1 ms page erase specification to get a shorter cycle time.

2.8.3 FLASH Mass Erase Operation

Use this step-by-step procedure to erase the entire FLASH memory.

1. Set both the ERASE bit and the MASS bit in the FLASH control register.
2. Read the FLASH block protect register.
3. Write any data to any FLASH address⁽¹⁾ within the FLASH memory address range.
4. Wait for a time, t_{NVS} (minimum 10 μ s).
5. Set the HVEN bit.
6. Wait for a time, t_{MErase} (minimum 4 ms).
7. Clear the ERASE and MASS bits.

NOTE: Mass erase is disabled whenever any block is protected (FLBPR does not equal \$FF).

1. When in monitor mode, with security sequence failed (see [18.3.2 Security](#)), write to the FLASH block protect register instead of any FLASH address.

8. Wait for a time, t_{NVHL} (minimum 100 μ s).
9. Clear the HVEN bit.
10. After time, t_{RCV} (typical 1 μ s), the memory can be accessed in read mode again.

NOTE: *Programming and erasing of FLASH locations cannot be performed by code being executed from the FLASH memory. While these operations must be performed in the order shown, other unrelated operations may occur between the steps.*

2.8.4 FLASH Program Operation

Use the following step-by-step procedure to program a row of FLASH memory. **Figure 2-4** shows a flowchart of the programming algorithm.

NOTE: *Only bytes which are currently \$FF may be programmed.*

1. Set the PGM bit. This configures the memory for program operation and enables the latching of address and data for programming.
2. Read the FLASH block protect register.
3. Write any data to any FLASH location within the address range desired.
4. Wait for a time, t_{NVS} (minimum 10 μ s).
5. Set the HVEN bit.
6. Wait for a time, t_{PGS} (minimum 5 μ s).
7. Write data to the FLASH address being programmed⁽¹⁾.
8. Wait for time, t_{PROG} (minimum 30 μ s).
9. Repeat step 7 and 8 until all desired bytes within the row are programmed.
10. Clear the PGM bit⁽¹⁾.
11. Wait for time, t_{NVH} (minimum 5 μ s).
12. Clear the HVEN bit.
13. After time, t_{RCV} (typical 1 μ s), the memory can be accessed in read mode again.

NOTE: *The COP register at location \$FFFF should not be written between steps 5-12, when the HVEN bit is set. Since this register is located at a valid FLASH address, unpredictable behavior may occur if this location is written while HVEN is set.*

This program sequence is repeated throughout the memory until all data is programmed.

NOTE: *Programming and erasing of FLASH locations cannot be performed by code being executed from the FLASH memory. While these operations must be performed in the order shown, other unrelated operations may occur between the steps. Do not exceed t_{PROG} maximum, see **19.6 FLASH Memory Characteristics**.*

1. The time between each FLASH address change, or the time between the last FLASH address programmed to clearing PGM bit, must not exceed the maximum programming time, t_{PROG} maximum.

**ALGORITHM FOR PROGRAMMING
A ROW (64 BYTES) OF FLASH MEMORY**

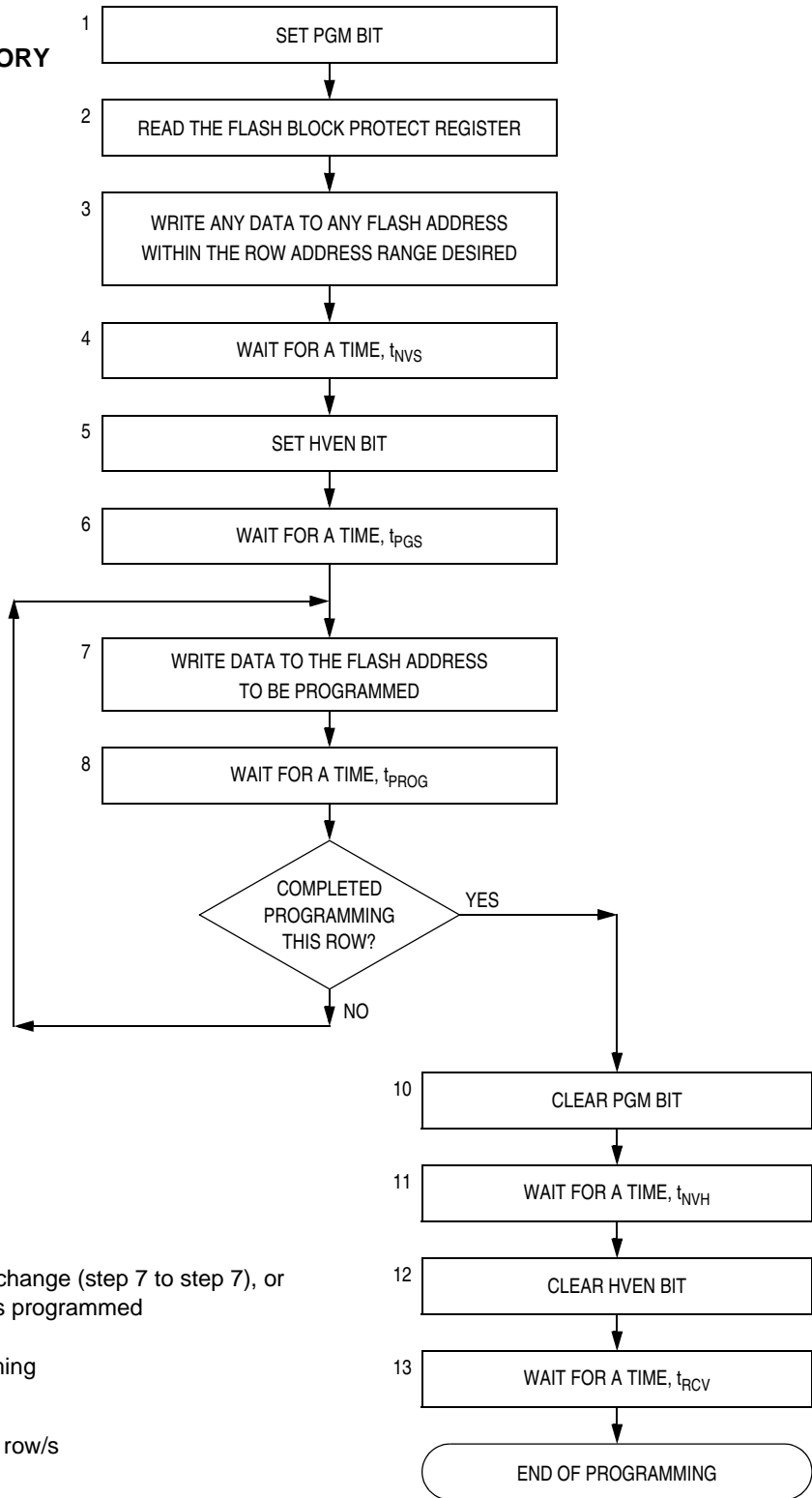

Note:

The time between each FLASH address change (step 7 to step 7), or the time between the last FLASH address programmed to clearing PGM bit (step 7 to step 10) must not exceed the maximum programming time, $t_{PROG\ max}$.

This row program algorithm assumes the row/s to be programmed are initially erased.

Figure 2-4. FLASH Programming Flowchart

2.8.5 FLASH Block Protection

Due to the ability of the on-board charge pump to erase and program the FLASH memory in the target application, provision is made for protecting a block of memory from unintentional erase or program operations due to system malfunction. This protection is done by using a FLASH block protect register (FLBPR).

The FLBPR determines the range of the FLASH memory which is to be protected. The range of the protected area starts from a location defined by FLBPR and ends at the bottom of the FLASH memory (\$FFFF). When the memory is protected, the HVEN bit cannot be set in either ERASE or PROGRAM operations.

NOTE: *In performing a program or erase operation, the FLASH block protect register must be read after setting the PGM or ERASE bit and before asserting the HVEN bit*

When the FLBPR is programmed with all 0s, the entire memory is protected from being programmed and erased. When all the bits are erased (all 1s), the entire memory is accessible for program and erase.

When bits within the FLBPR are programmed, they lock a block of memory, whose address ranges are shown in **2.8.6 FLASH Block Protect Register**. Once the FLBPR is programmed with a value other than \$FF, any erase or program of the FLBPR or the protected block of FLASH memory is prohibited. Mass erase is disabled whenever any block is protected (FLBPR does not equal \$FF). The FLBPR itself can be erased or programmed only with an external voltage, V_{TST} , present on the \overline{IRQ} pin. This voltage also allows entry from reset into the monitor mode.

2.8.6 FLASH Block Protect Register

The FLASH block protect register (FLBPR) is implemented as a byte within the FLASH memory, and therefore can be written only during a programming sequence of the FLASH memory. The value in this register determines the starting location of the protected range within the FLASH memory.

Address:	\$FF7E							
	Bit 7	6	5	4	3	2	1	Bit 0
Read:	BPR7	BPR6	BPR5	BPR4	BPR3	BPR2	BPR1	BPR0
Write:								
Reset:	0	0	0	0	0	0	0	0

U = Unaffected by reset. Initial value from factory is 1.

Write to this register by a programming sequence to the FLASH memory.

Figure 2-5. FLASH Block Protect Register (FLBPR)

BPR[7:0] — FLASH Block Protect Bits

These eight bits represent bits [14:7] of a 16-bit memory address. Bit 15 is 1 and bits [6:0] are 0s.

The resultant 16-bit address is used for specifying the start address of the FLASH memory for block protection. The FLASH is protected from this start address to the end of FLASH memory at \$FFFF. With this mechanism, the protect start address can be XX00 and XX80 (128 bytes page boundaries) within the FLASH memory.

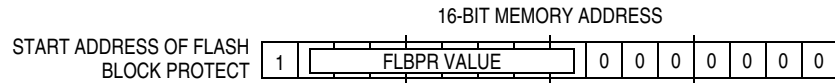

Figure 2-6. FLASH Block Protect Start Address

Refer to Table 2-2 for examples of the protect start address.

Table 2-2. Examples of Protect Start Address

BPR[7:0]	Start of Address of Protect Range
\$00	The entire FLASH memory is protected.
\$01 (0000 0001)	\$8080 (1000 0000 1000 0000)
\$02 (0000 0010)	\$8100 (1000 0001 0000 0000)
and so on...	
\$FE (1111 1110)	\$FF00 (1111 1111 0000 0000)
\$FF	The entire FLASH memory is not protected.

Note: The end address of the protected range is always \$FFFF.

2.8.7 Wait Mode

Putting the MCU into wait mode while the FLASH is in read mode does not affect the operation of the FLASH memory directly, but there will not be any memory activity since the CPU is inactive.

The WAIT instruction should not be executed while performing a program or erase operation on the FLASH. Otherwise, the operation will discontinue, and the FLASH will be on standby mode.

2.8.8 Stop Mode

Putting the MCU into stop mode while the FLASH is in read mode does not affect the operation of the FLASH memory directly, but there will not be any memory activity since the CPU is inactive.

The STOP instruction should not be executed while performing a program or erase operation on the FLASH, otherwise the operation will discontinue, and the FLASH will be on standby mode

NOTE: Standby mode is the power-saving mode of the FLASH module in which all internal control signals to the FLASH are inactive and the current consumption of the FLASH is at a minimum.

Section 3. Analog-to-Digital Converter (ADC)

3.1 Introduction

This section describes the 10-bit analog-to-digital converter (ADC).

3.2 Features

Features of the ADC module include:

- 10 channels with multiplexed input
- Linear successive approximation
- 10-bit resolution, 8-bit accuracy
- Single or continuous conversion
- Conversion complete flag or conversion complete interrupt
- Selectable ADC clock
- Left or right justified result
- Left justified sign data mode
- High impedance buffered ADC input

3.3 Functional Description

Ten ADC channels are available for sampling external sources at pins PTC1/ATD9:PTC0/ATD8 and PTB7/ATD7:PTB0/ATD0. To achieve the best possible accuracy, these pins are implemented as input-only pins when the analog-to-digital (A/D) feature is enabled. An analog multiplexer allows the single ADC to select one of the 10 ADC channels as ADC voltage IN (ADCVIN). ADCVIN is converted by the successive approximation algorithm. When the conversion is completed, the ADC places the result in the ADC data register (ADRH and ADRL) and sets a flag or generates an interrupt. See [Figure 3-2](#).

Analog-to-Digital Converter (ADC)

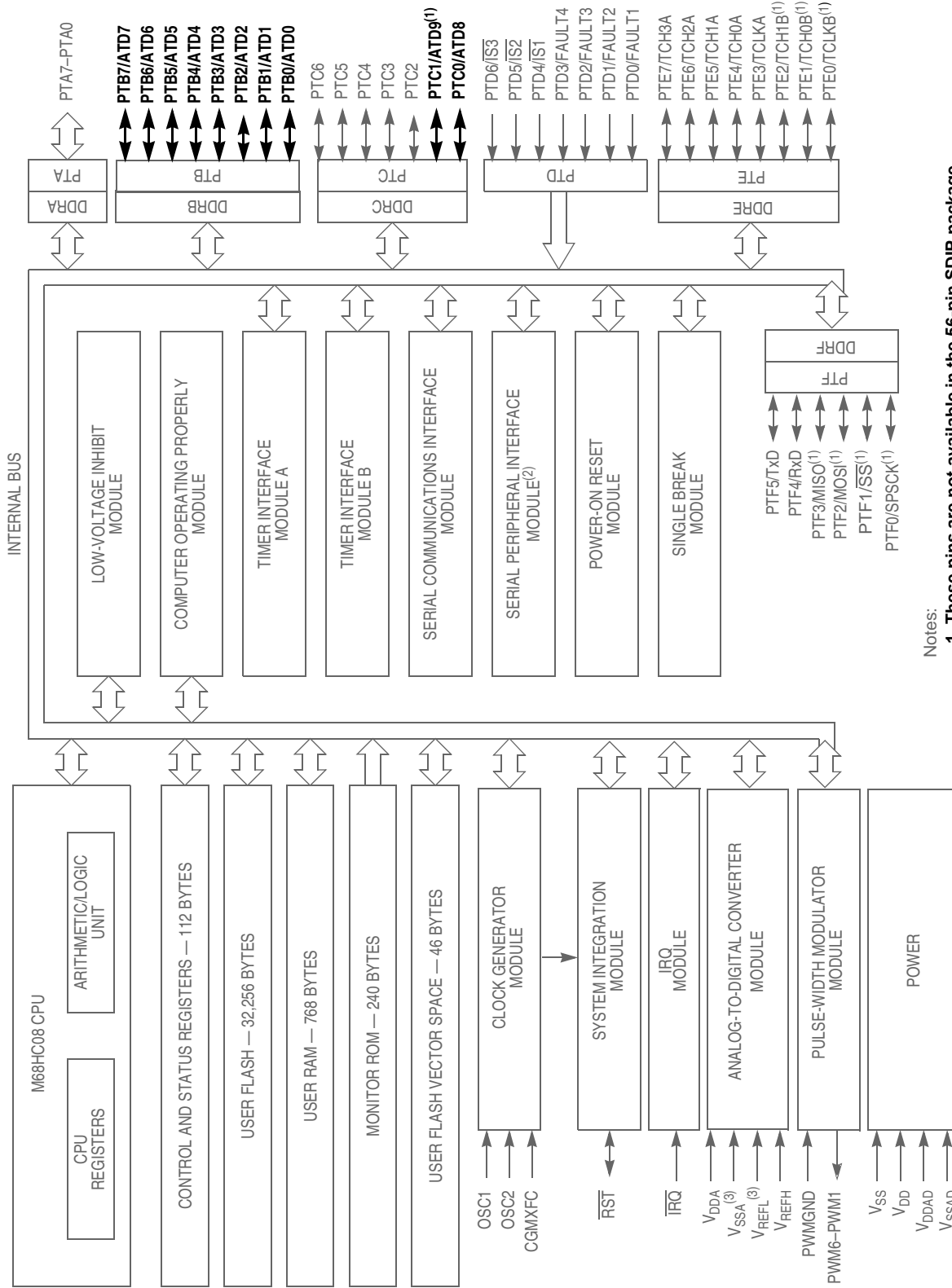

- Notes:
1. These pins are not available in the 56-pin SDIP package.
 2. This module is not available in the 56-pin SDIP package.
 3. In the 56-pin SDIP package, these pins are bonded together.

Figure 3-1. Block Diagram Highlighting ADC Block and Pins

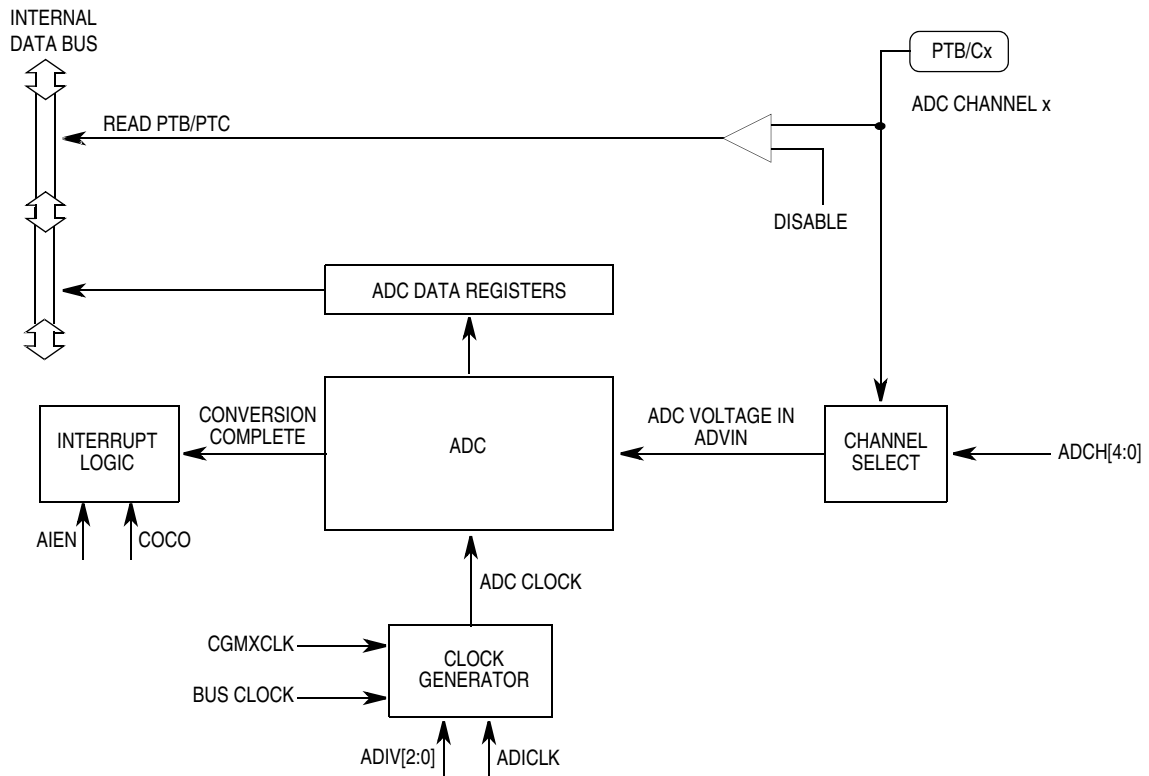

Figure 3-2. ADC Block Diagram

3.3.1 ADC Port I/O Pins

PTC1/ATD9:PTC0/ATD8 and PTB7/ATD7:PTB0/ATD0 are general-purpose I/O pins that are shared with the ADC channels.

The channel select bits define which ADC channel/port pin will be used as the input signal. The ADC overrides the port logic when that port is selected by the ADC multiplexer. The remaining ADC channels/port pins are controlled by the port logic and can be used as general-purpose input/output (I/O) pins. Writes to the port register or DDR will not have any effect on the port pin that is selected by the ADC. Read of a port pin which is in use by the ADC will return a 0.

3.3.2 Voltage Conversion

When the input voltage to the ADC equals V_{REFH} , the ADC converts the signal to \$3FF (full scale). If the input voltage equals V_{REFL} , the ADC converts it to \$000. Input voltages between V_{REFH} and V_{REFL} are straight-line linear conversions. All other input voltages will result in \$3FF if greater than V_{REFH} and \$000 if less than V_{REFL} .

NOTE: *Input voltage should not exceed the analog supply voltages. See [19.13 Analog-to-Digital Converter \(ADC\) Characteristics](#).*

3.3.3 Conversion Time

Conversion starts after a write to the ADSCR. A conversion is between 16 and 17 ADC clock cycles, therefore:

$$\text{Conversion time} = \frac{16 \text{ to } 17 \text{ ADC Cycles}}{\text{ADC Frequency}}$$

$$\text{Number of Bus Cycles} = \text{Conversion Time} \times \text{CPU Bus Frequency}$$

The ADC conversion time is determined by the clock source chosen and the divide ratio selected. The clock source is either the bus clock or CGMXCLK and is selectable by ADICLK located in the ADC clock register. For example, if CGMXCLK is 4 MHz and is selected as the ADC input clock source, the ADC input clock divide-by-4 prescale is selected and the CPU bus frequency is 8 MHz:

$$\text{Conversion Time} = \frac{16 \text{ to } 17 \text{ ADC Cycles}}{4 \text{ MHz}/4} = 16 \text{ to } 17 \mu\text{s}$$

$$\text{Number of bus cycles} = 16 \mu\text{s} \times 8 \text{ MHz} = 128 \text{ to } 136 \text{ cycles}$$

NOTE: The ADC frequency must be between f_{ADIC} minimum and f_{ADIC} maximum to meet A/D specifications. See [19.13 Analog-to-Digital Converter \(ADC\) Characteristics](#).

Since an ADC cycle may be comprised of several bus cycles (eight, 136 minus 128, in the previous example) and the start of a conversion is initiated by a bus cycle write to the ADSCR, from zero to eight additional bus cycles may occur before the start of the initial ADC cycle. This results in a fractional ADC cycle and is represented as the 17th cycle.

3.3.4 Continuous Conversion

In continuous conversion mode, the ADC data registers ADRH and ADRL will be filled with new data after each conversion. Data from the previous conversion will be overwritten whether that data has been read or not. Conversions will continue until the ADCO bit is cleared. The COCO bit is set after each conversion and will stay set until the next read of the ADC data register.

When a conversion is in process and the ADSCR is written, the current conversion data should be discarded to prevent an incorrect reading.

3.3.5 Result Justification

The conversion result may be formatted in four different ways:

1. Left justified
2. Right justified
3. Left Justified sign data mode
4. 8-bit truncation mode

All four of these modes are controlled using MODE0 and MODE1 bits located in the ADC clock register (ADCR).

Left justification will place the eight most significant bits (MSB) in the corresponding ADC data register high, ADRH. This may be useful if the result is to be treated as an 8-bit result where the two least significant bits (LSB), located in the ADC data register low, ADRL, can be ignored. However, ADRL must be read after ADRH or else the interlocking will prevent all new conversions from being stored.

Right justification will place only the two MSBs in the corresponding ADC data register high, ADRH, and the eight LSBs in ADC data register low, ADRL. This mode of operation typically is used when a 10-bit unsigned result is desired.

Left justified sign data mode is similar to left justified mode with one exception. The MSB of the 10-bit result, AD9 located in ADRH, is complemented. This mode of operation is useful when a result, represented as a signed magnitude from mid-scale, is needed. Finally, 8-bit truncation mode will place the eight MSBs in ADC data register low, ADRL. The two LSBs are dropped. This mode of operation is used when compatibility with 8-bit ADC designs are required. No interlocking between ADRH and ADRL is present.

NOTE: Quantization error is affected when only the most significant eight bits are used as a result. See [Figure 3-3](#).

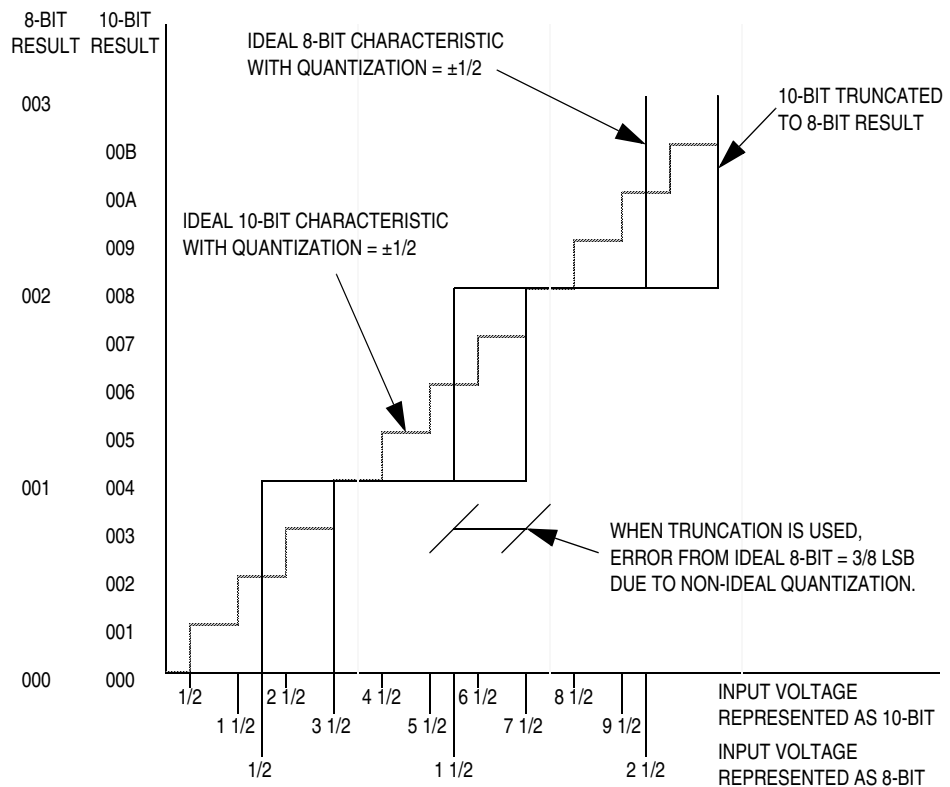

Figure 3-3. 8-Bit Truncation Mode Error

3.3.6 Monotonicity

The conversion process is monotonic and has no missing codes.

3.4 Interrupts

When the AIEN bit is set, the ADC module is capable of generating a CPU interrupt after each ADC conversion. A CPU interrupt is generated if the COCO bit is at 0. The COCO bit is not used as a conversion complete flag when interrupts are enabled.

3.5 Wait Mode

The WAIT instruction can put the MCU in low power-consumption standby mode.

The ADC continues normal operation during wait mode. Any enabled CPU interrupt request from the ADC can bring the MCU out of wait mode. If the ADC is not required to bring the MCU out of wait mode, power down the ADC by setting ADCH[4:0] in the ADC status and control register before executing the WAIT instruction.

3.6 I/O Signals

The ADC module has 10 input signals that are shared with port B and port C.

3.6.1 ADC Analog Power Pin (V_{DDAD})

The ADC analog portion uses V_{DDAD} as its power pin. Connect the V_{DDAD} pin to the same voltage potential as V_{DD} . External filtering may be necessary to ensure clean V_{DDAD} for good results.

NOTE: Route V_{DDAD} carefully for maximum noise immunity and place bypass capacitors as close as possible to the package.

3.6.2 ADC Analog Ground Pin (V_{SSAD})

The ADC analog portion uses V_{SSAD} as its ground pin. Connect the V_{SSAD} pin to the same voltage potential as V_{SS} .

3.6.3 ADC Voltage Reference Pin (V_{REFH})

V_{REFH} is the power supply for setting the reference voltage V_{REFH} . Connect the V_{REFH} pin to the same voltage potential as V_{DDAD} . There will be a finite current associated with V_{REFH} . See [Section 19. Electrical Specifications](#).

NOTE: Route V_{REFH} carefully for maximum noise immunity and place bypass capacitors as close as possible to the package.

3.6.4 ADC Voltage Reference Low Pin (V_{REFL})

V_{REFL} is the lower reference supply for the ADC. Connect the V_{REFL} pin to the same voltage potential as V_{SSAD} . A finite current will be associated with V_{REFL} . See [Section 19. Electrical Specifications](#).

NOTE: *In the 56-pin shrink dual in-line package (SDIP), V_{REFL} and V_{SSAD} are tied together.*

3.6.5 ADC Voltage In (ADVIN)

ADVIN is the input voltage signal from one of the 10 ADC channels to the ADC module.

3.6.6 ADC External Connections

This section describes the ADC external connections: V_{REFH} and V_{REFL} , ANx, and grounding.

3.6.6.1 V_{REFH} and V_{REFL}

Both ac and dc current are drawn through the V_{REFH} and V_{REFL} loop. The AC current is in the form of current spikes required to supply charge to the capacitor array at each successive approximation step. The current flows through the internal resistor string. The best external component to meet both these current demands is a capacitor in the 0.01 μF to 1 μF range with good high frequency characteristics. This capacitor is connected between V_{REFH} and V_{REFL} and must be placed as close as possible to the package pins. Resistance in the path is not recommended because the dc current will cause a voltage drop which could result in conversion errors.

3.6.6.2 ANx

Empirical data shows that capacitors from the analog inputs to V_{REFL} improve ADC performance. 0.01- μF and 0.1- μF capacitors with good high-frequency characteristics are sufficient. These capacitors must be placed as close as possible to the package pins.

3.6.6.3 Grounding

In cases where separate power supplies are used for analog and digital power, the ground connection between these supplies should be at the V_{SSAD} pin. This should be the only ground connection between these supplies if possible. The V_{SSA} pin makes a good single point ground location. Connect the V_{REFL} pin to the same potential as V_{SSAD} at the single point ground location.

3.7 I/O Registers

These I/O registers control and monitor operation of the ADC:

- ADC status and control register, ADSCR
- ADC data registers, ADRH and ARDL
- ADC clock register, ADCLK

3.7.1 ADC Status and Control Register

This section describes the function of the ADC status and control register (ADSCR). Writing ADSCR aborts the current conversion and initiates a new conversion.

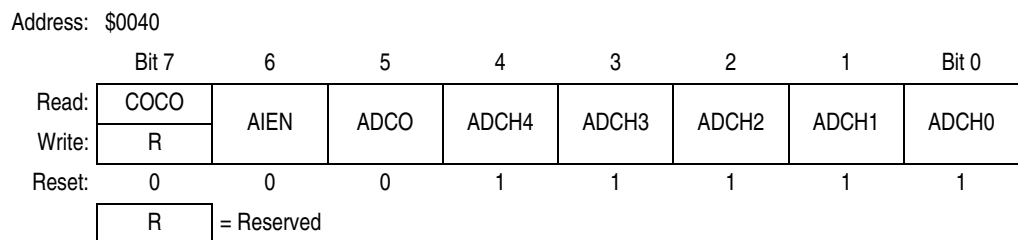

Figure 3-4. ADC Status and Control Register (ADSCR)

COCO — Conversions Complete Bit

In non-interrupt mode (AIEN = 0), COCO is a read-only bit that is set at the end of each conversion. COCO will stay set until cleared by a read of the ADC data register. Reset clears this bit.

In interrupt mode (AIEN = 1), COCO is a read-only bit that is not set at the end of a conversion. It always reads as a 0.

1 = Conversion completed (AIEN = 0)

0 = Conversion not completed (AIEN = 0) or CPU interrupt enabled (AIEN = 1)

NOTE: The write function of the COCO bit is reserved. When writing to the ADSCR register, always have a 0 in the COCO bit position.

AIEN — ADC Interrupt Enable Bit

When this bit is set, an interrupt is generated at the end of an ADC conversion. The interrupt signal is cleared when the data register is read or the status/control register is written. Reset clears the AIEN bit.

1 = ADC interrupt enabled

0 = ADC interrupt disabled

ADCO — ADC Continuous Conversion Bit

When set, the ADC will convert samples continuously and update the ADR register at the end of each conversion. Only one conversion is allowed when this bit is cleared. Reset clears the ADCO bit.

1 = Continuous ADC conversion

0 = One ADC conversion

ADCH[4:0] — ADC Channel Select Bits

ADCH4, ADCH3, ADCH2, ADCH1, and ADCH0 form a 5-bit field which is used to select one of 10 ADC channels. The ADC channels are detailed in [Table 3-1](#).

NOTE: Take care to prevent switching noise from corrupting the analog signal when simultaneously using a port pin as both an analog and digital input.

The ADC subsystem is turned off when the channel select bits are all set to 1. This feature allows for reduced power consumption for the MCU when the ADC is not used.

NOTE: Recovery from the disabled state requires one conversion cycle to stabilize.

The voltage levels supplied from internal reference nodes as specified in [Table 3-1](#) are used to verify the operation of the ADC both in production test and for user applications.

Table 3-1. Mux Channel Select

ADCH4	ADCH3	ADCH2	ADCH1	ADCH0	Input Select
0	0	0	0	0	PTB0/ATD0
0	0	0	0	1	PTB1/ATD1
0	0	0	1	0	PTB2/ATD2
0	0	0	1	1	PTB3/ATD3
0	0	1	0	0	PTB4/ATD4
0	0	1	0	1	PTB5/ATD5
0	0	1	1	0	PTB6/ATD6
0	0	1	1	1	PTB7/ATD7
0	1	0	0	0	PTC0/ATD8
0	1	0	0	1	PTC1/ATD9 ⁽¹⁾
0	1	0	1	0	Unused ⁽²⁾
0	1	0	1	1	∅
0	1	1	0	0	∅
0	1	1	0	1	∅
0	1	1	1	0	∅
0	1	1	1	1	∅
1	0	0	0	0	∅
1	1	0	1	0	Unused ⁽²⁾
1	1	0	1	1	Reserved ⁽³⁾
1	1	1	0	0	Unused ⁽²⁾
1	1	1	0	1	V _{REFH}
1	1	1	1	0	V _{REFL}
1	1	1	1	1	ADC power off

1. ATD9 is not available in the 56-pin SDIP package.

2. Used for factory testing.

3. If any unused channels are selected, the resulting ADC conversion will be unknown.

3.7.2 ADC Data Register High

In left justified mode, this 8-bit result register holds the eight MSBs of the 10-bit result. This register is updated each time an ADC single channel conversion completes. Reading ADRH latches the contents of ADRL until ADRL is read. Until ADRL is read, all subsequent ADC results will be lost.

Address: \$0041

	Bit 7	6	5	4	3	2	1	Bit 0
Read:	AD9	AD8	AD7	AD6	AD5	AD4	AD3	AD2
Write:	R	R	R	R	R	R	R	R

Reset: Unaffected by reset

R = Reserved

Figure 3-5. ADC Data Register High (ADRH) Left Justified Mode

In right justified mode, this 8-bit result register holds the two MSBs of the 10-bit result. All other bits read as 0. This register is updated each time a single channel ADC conversion completes. Reading ADRH latches the contents of ADRL until ADRL is read. Until ADRL is read, all subsequent ADC results will be lost.

Address: \$0041

	Bit 7	6	5	4	3	2	1	Bit 0
Read:	0	0	0	0	0	0	AD9	AD8
Write:	R	R	R	R	R	R	R	R

Reset: Unaffected by reset

R = Reserved

Figure 3-6. ADC Data Register High (ADRH) Right Justified Mode

3.7.3 ADC Data Register Low

In left justified mode, this 8-bit result register holds the two LSBs of the 10-bit result. All other bits read as 0. This register is updated each time a single channel ADC conversion completes. Reading ADRH latches the contents of ADRL until ADRL is read. Until ADRL is read, all subsequent ADC results will be lost.

Address: \$0042

	Bit 7	6	5	4	3	2	1	Bit 0
Read:	AD1	AD0	0	0	0	0	0	0
Write:	R	R	R	R	R	R	R	R

Reset: Unaffected by reset

R = Reserved

Figure 3-7. ADC Data Register Low (ADRL) Left Justified Mode

In right justified mode, this 8-bit result register holds the eight LSBs of the 10-bit result. This register is updated each time an ADC conversion completes. Reading ADRH latches the contents of ADRL until ADRL is read. Until ADRL is read, all subsequent ADC results will be lost.

Address: \$0042

	Bit 7	6	5	4	3	2	1	Bit 0
Read:	AD7	AD6	AD5	AD4	AD3	AD2	AD1	AD0
Write:	R	R	R	R	R	R	R	R
Reset:	Unaffected by reset							

R = Reserved

Figure 3-8. ADC Data Register Low (ADRL) Right Justified Mode

In 8-bit mode, this 8-bit result register holds the eight MSBs of the 10-bit result. This register is updated each time an ADC conversion completes. In 8-bit mode, this register contains no interlocking with ADRH.

Address: \$0042

	Bit 7	6	5	4	3	2	1	Bit 0
Read:	AD9	AD8	AD7	AD6	AD5	AD4	AD3	AD2
Write:	R	R	R	R	R	R	R	R
Reset:	Unaffected by reset							

R = Reserved

Figure 3-9. ADC Data Register Low (ADRL) 8-Bit Mode

3.7.4 ADC Clock Register

This register selects the clock frequency for the ADC, selecting between modes of operation.

Address: \$0043

	Bit 7	6	5	4	3	2	1	Bit 0
Read:	ADIV2	ADIV1	ADIV0	ADICLK	MODE1	MODE0	0	0
Write:								R
Reset:	0	0	0	0	0	1	0	0

R = Reserved

Figure 3-10. ADC Clock Register (ADCLK)

ADIV2:ADIV0 — ADC Clock Prescaler Bits

ADIV2, ADIV1, and ADIV0 form a 3-bit field which selects the divide ratio used by the ADC to generate the internal ADC clock. [Table 3-2](#) shows the available clock configurations.

Table 3-2. ADC Clock Divide Ratio

ADIV2	ADIV1	ADIV0	ADC Clock Rate
0	0	0	ADC input clock ÷ 1
0	0	1	ADC input clock ÷ 2
0	1	0	ADC input clock ÷ 4
0	1	1	ADC input clock ÷ 8
1	X	X	ADC input clock ÷ 16

X = don't care

ADICLK — ADC Input Clock Select Bit

ADICLK selects either bus clock or CGMXCLK as the input clock source to generate the internal ADC clock. Reset selects CGMXCLK as the ADC clock source.

If the external clock (CGMXCLK) is equal to or greater than 1 MHz, CGMXCLK can be used as the clock source for the ADC. If CGMXCLK is less than 1 MHz, use the PLL-generated bus clock as the clock source. As long as the internal ADC clock is at f_{ADIC} , correct operation can be guaranteed. See [19.13](#)

Analog-to-Digital Converter (ADC) Characteristics.

- 1 = Internal bus clock
- 0 = External clock, CGMXCLK

$$f_{ADIC} = \frac{\text{CGMXCLK or bus frequency}}{\text{ADIV}[2:0]}$$

MODE1:MODE0 — Modes of Result Justification Bits

MODE1:MODE0 selects among four modes of operation. The manner in which the ADC conversion results will be placed in the ADC data registers is controlled by these modes of operation. Reset returns right-justified mode.

- 00 = 8-bit truncation mode
- 01 = Right justified mode
- 10 = Left justified mode
- 11 = Left justified sign data mode

Section 4. Clock Generator Module (CGM)

4.1 Introduction

This section describes the clock generator module (CGM, version A). The CGM generates the crystal clock signal, CGMXCLK, which operates at the frequency of the crystal. The CGM also generates the base clock signal, CGMOUT, from which the system integration module (SIM) derives the system clocks.

CGMOUT is based on either the crystal clock divided by two or the phase-locked loop (PLL) clock, CGMVCLK, divided by two. The PLL is a frequency generator designed for use with crystals or ceramic resonators. The PLL can generate an 8-MHz bus frequency without using a 32-MHz external clock.

4.2 Features

Features of the CGM include:

- PLL with output frequency in integer multiples of the crystal reference
- Programmable hardware voltage-controlled oscillator (VCO) for low-jitter operation
- Automatic bandwidth control mode for low-jitter operation
- Automatic frequency lock detector
- Central processor unit (CPU) interrupt on entry or exit from locked condition

4.3 Functional Description

The CGM consists of three major submodules:

1. Crystal oscillator circuit — The crystal oscillator circuit generates the constant crystal frequency clock, CGMXCLK.
2. Phase-locked loop (PLL) — The PLL generates the programmable VCO frequency clock, CGMVCLK.
3. Base clock selector circuit — This software-controlled circuit selects either CGMXCLK divided by two or the VCO clock, CGMVCLK, divided by two as the base clock, CGMOUT. The SIM derives the system clocks from CGMOUT.

Figure 4-1 shows the structure of the CGM.

Clock Generator Module (CGM)

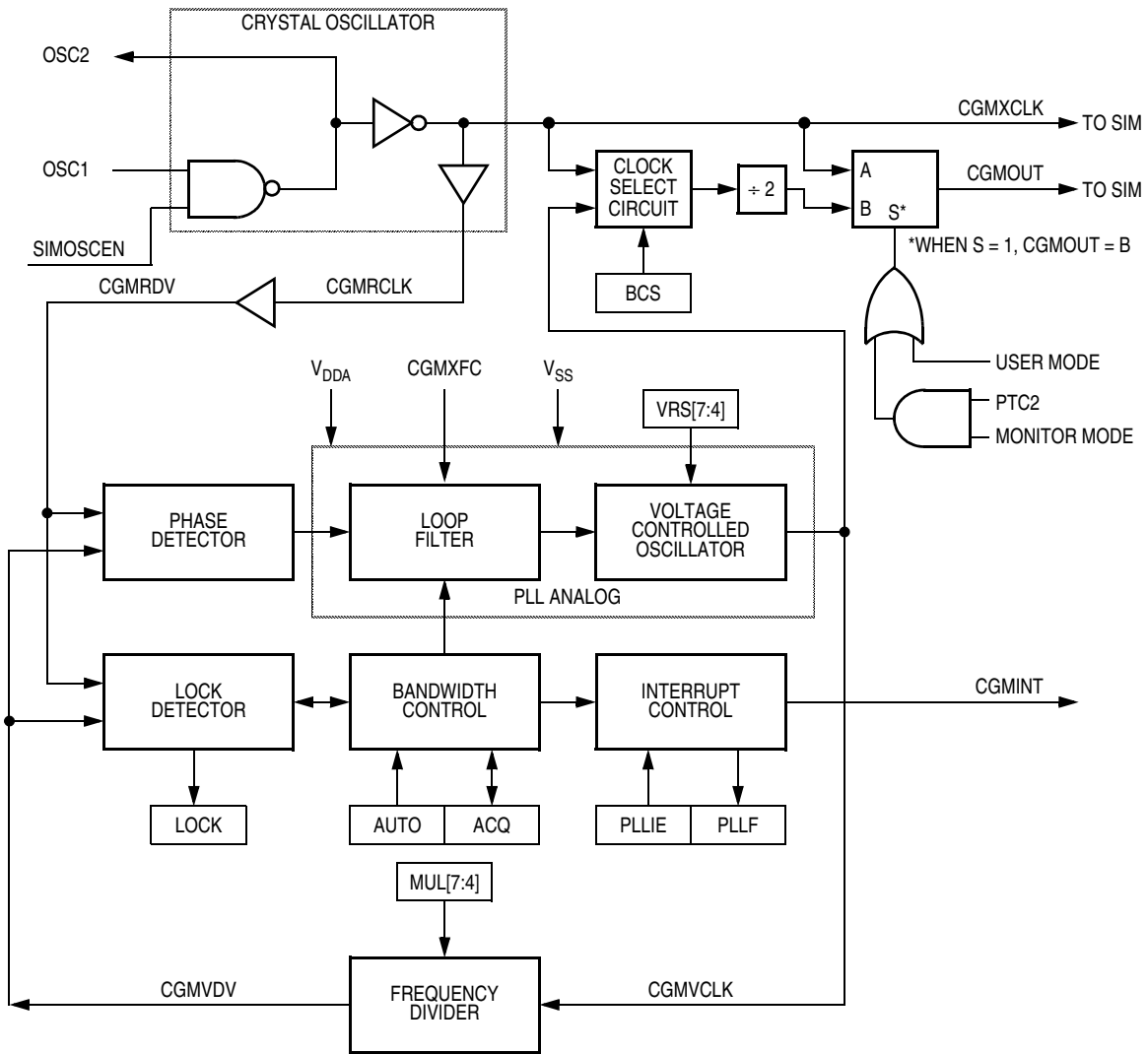

Figure 4-1. CGM Block Diagram

Addr.	Register Name		Bit 7	6	5	4	3	2	1	Bit 0	
\$005C	PLL Control Register (PCTL) <i>See page 69.</i>	Read:	PLLIE	PLL \overline{F}	PLLON	BCS	1	1	1	1	
		Write:		R			R	R	R	R	
		Reset:	0	0	1	0	1	1	1	1	
\$005D	PLL Bandwidth Control Register (PBWC) <i>See page 71.</i>	Read:	AUTO	LOCK	\overline{ACQ}	XLD	0	0	0	0	
		Write:		R			R	R	R	R	
		Reset:	0	0	0	0	0	0	0	0	
\$005E	PLL Programming Register (PPG) <i>See page 72.</i>	Read:	MUL7	MUL6	MUL5	MUL4	VRS7	VRS6	VRS5	VRS4	
		Write:									
		Reset:	0	1	1	0	0	1	1	0	

R = Reserved

Figure 4-2. CGM I/O Register Summary

4.3.1 Crystal Oscillator Circuit

The crystal oscillator circuit consists of an inverting amplifier and an external crystal. The OSC1 pin is the input to the amplifier and the OSC2 pin is the output. The SIMOSCEN signal from the system integration module (SIM) enables the crystal oscillator circuit.

The CGMXCLK signal is the output of the crystal oscillator circuit and runs at a rate equal to the crystal frequency. CGMXCLK is then buffered to produce CGMRCLK, the PLL reference clock.

CGMXCLK can be used by other modules which require precise timing for operation. The duty cycle of CGMXCLK is not guaranteed to be 50 percent and depends on external factors, including the crystal and related external components.

An externally generated clock also can feed the OSC1 pin of the crystal oscillator circuit. Connect the external clock to the OSC1 pin and let the OSC2 pin float.

4.3.2 Phase-Locked Loop Circuit (PLL)

The PLL is a frequency generator that can operate in either acquisition mode or tracking mode, depending on the accuracy of the output frequency. The PLL can change between acquisition and tracking modes either automatically or manually.

4.3.2.1 PLL Circuits

The PLL consists of these circuits:

- Voltage-controlled oscillator (VCO)
- Modulo VCO frequency divider
- Phase detector
- Loop filter
- Lock detector

The operating range of the VCO is programmable for a wide range of frequencies and for maximum immunity to external noise, including supply and CGMXFC noise. The VCO frequency is bound to a range from roughly one-half to twice the center-of-range frequency, f_{VRS} . Modulating the voltage on the CGMXFC pin changes the frequency within this range. By design, f_{VRS} is equal to the nominal center-of-range frequency, f_{NOM} , (4.9152 MHz) times a linear factor, L or (L) f_{NOM} .

CGMRCLK is the PLL reference clock, a buffered version of CGMXCLK. CGMRCLK runs at a frequency, f_{RCLK} , and is fed to the PLL through a buffer. The buffer output is the final reference clock, CGMRDV, running at a frequency, $f_{RDV} = f_{RCLK}$.

The VCO's output clock, CGMVCLK, running at a frequency, f_{VCLK} , is fed back through a programmable modulo divider. The modulo divider reduces the VCO

clock by a factor, N . The divider's output is the VCO feedback clock, CGMV_{DV}, running at a frequency, $f_{VDV} = f_{VCLK}/N$. (See [4.3.2.4 Programming the PLL](#) for more information.)

The phase detector then compares the VCO feedback clock, CGMV_{DV}, with the final reference clock, CGMR_{DV}. A correction pulse is generated based on the phase difference between the two signals. The loop filter then slightly alters the dc voltage on the external capacitor connected to CGMXFC based on the width and direction of the correction pulse. The filter can make fast or slow corrections depending on its mode, described in [4.3.2.2 Acquisition and Tracking Modes](#). The value of the external capacitor and the reference frequency determines the speed of the corrections and the stability of the PLL.

The lock detector compares the frequencies of the VCO feedback clock, CGMV_{DV}, and the final reference clock, CGMR_{DV}. Therefore, the speed of the lock detector is directly proportional to the final reference frequency, f_{RDV} . The circuit determines the mode of the PLL and the lock condition based on this comparison.

4.3.2.2 Acquisition and Tracking Modes

The PLL filter is manually or automatically configurable into one of two operating modes:

1. Acquisition mode — In acquisition mode, the filter can make large frequency corrections to the VCO. This mode is used at PLL startup or when the PLL has suffered a severe noise hit and the VCO frequency is far off the desired frequency. When in acquisition mode, the \overline{ACQ} bit is clear in the PLL bandwidth control register. See [4.5.2 PLL Bandwidth Control Register](#).
2. Tracking mode — In tracking mode, the filter makes only small corrections to the frequency of the VCO. PLL jitter is much lower in tracking mode, but the response to noise is also slower. The PLL enters tracking mode when the VCO frequency is nearly correct, such as when the PLL is selected as the base clock source. See [4.3.3 Base Clock Selector Circuit](#). The PLL is automatically in tracking mode when not in acquisition mode or when the \overline{ACQ} bit is set.

4.3.2.3 Manual and Automatic PLL Bandwidth Modes

The PLL can change the bandwidth or operational mode of the loop filter manually or automatically.

In automatic bandwidth control mode ($AUTO = 1$), the lock detector automatically switches between acquisition and tracking modes. Automatic bandwidth control mode also is used to determine when the VCO clock, CGMV_{CLK}, is safe to use as the source for the base clock, CGM_{OUT}. See [4.5.2 PLL Bandwidth Control Register](#). If PLL interrupts are enabled, the software can wait for a PLL interrupt request and then check the LOCK bit. If interrupts are disabled, software can poll the LOCK bit continuously (during PLL startup, usually) or at periodic intervals. In either case, when the LOCK bit is set, the VCO clock is safe to use as the source

for the base clock. See [4.3.3 Base Clock Selector Circuit](#). If the VCO is selected as the source for the base clock and the LOCK bit is clear, the PLL has suffered a severe noise hit and the software must take appropriate action, depending on the application. See [4.6 Interrupts](#) for information and precautions on using interrupts.

These conditions apply when the PLL is in automatic bandwidth control mode:

- The \overline{ACQ} bit (see [4.5.2 PLL Bandwidth Control Register](#)) is a read-only indicator of the mode of the filter. For more information, see [4.3.2.2 Acquisition and Tracking Modes](#).
- The \overline{ACQ} bit is set when the VCO frequency is within a certain tolerance, Δ_{TRK} , and is cleared when the VCO frequency is out of a certain tolerance, Δ_{UNT} . For more information, see [4.8 Acquisition/Lock Time Specifications](#).
- The LOCK bit is a read-only indicator of the locked state of the PLL.
- The LOCK bit is set when the VCO frequency is within a certain tolerance, Δ_{Lock} , and is cleared when the VCO frequency is out of a certain tolerance, Δ_{UNL} . For more information, see [4.8 Acquisition/Lock Time Specifications](#).
- CPU interrupts can occur if enabled ($PLLIE = 1$) when the PLL's lock condition changes, toggling the LOCK bit. For more information, see [4.5.1 PLL Control Register](#).

The PLL also may operate in manual mode ($AUTO = 0$). Manual mode is used by systems that do not require an indicator of the lock condition for proper operation. Such systems typically operate well below f_{BUSMAX} and require fast startup. These conditions apply when in manual mode:

- \overline{ACQ} is a writable control bit that controls the mode of the filter. Before turning on the PLL in manual mode, the \overline{ACQ} bit must be clear.
- Before entering tracking mode ($\overline{ACQ} = 1$), software must wait a given time, t_{ACQ} (see [4.8 Acquisition/Lock Time Specifications](#)), after turning on the PLL by setting PLLON in the PLL control register (PCTL).
- Software must wait a given time, t_{AL} , after entering tracking mode before selecting the PLL as the clock source to CGMOUT ($BCS = 1$).
- The LOCK bit is disabled.
- CPU interrupts from the CGM are disabled.

4.3.2.4 Programming the PLL

Use this 9-step procedure to program the PLL. **Table 4-1** lists the variables used and their meaning.

Table 4-1. Variable Definitions

Variable	Definition
f_{BUSDES}	Desired bus clock frequency
f_{VCLKDES}	Desired VCO clock frequency
f_{RCLK}	Chosen reference crystal frequency
f_{VCLK}	Calculated VCO clock frequency
f_{BUS}	Calculated bus clock frequency
f_{NOM}	Nominal VCO center frequency
f_{VRS}	Shifted FCO center frequency

1. Choose the desired bus frequency, f_{BUSDES} .
Example: $f_{\text{BUSDES}} = 8 \text{ MHz}$
2. Calculate the desired VCO frequency, f_{VCLKDES} .
$$f_{\text{VCLKDES}} = 4 \times f_{\text{BUSDES}}$$
Example: $f_{\text{VCLKDES}} = 4 \times 8 \text{ MHz} = 32 \text{ MHz}$
3. Using a reference frequency, f_{RCLK} , equal to the crystal frequency, calculate the VCO frequency multiplier, N. Round the result to the nearest integer.

$$N = \frac{f_{\text{VCLKDES}}}{f_{\text{RCLK}}}$$

$$\text{Example: } N = \frac{32 \text{ MHz}}{4 \text{ MHz}} = 8 \text{ MHz}$$

4. Calculate the VCO frequency, f_{VCLK} .

$$f_{\text{VCLK}} = N \times f_{\text{RCLK}}$$

$$\text{Example: } f_{\text{VCLK}} = 8 \times 4 \text{ MHz} = 32 \text{ MHz}$$

5. Calculate the bus frequency, f_{BUS} , and compare f_{BUS} with f_{BUSDES} .

$$f_{\text{BUS}} = \frac{f_{\text{VCLK}}}{4}$$

$$\text{Example: } N = \frac{32 \text{ MHz}}{4 \text{ MHz}} = 8 \text{ MHz}$$

6. If the calculated f_{BUS} is not within the tolerance limits of the application, select another f_{BUSDES} or another f_{RCLK} .

7. Using the value 4.9152 MHz for f_{NOM} , calculate the VCO linear range multiplier, L. The linear range multiplier controls the frequency range of the PLL.

$$L = \text{round} \left(\frac{f_{\text{VCLK}}}{f_{\text{NOM}}} \right)$$

$$\text{Example: } L = \frac{32 \text{ MHz}}{4.9152 \text{ MHz}} = 7 \text{ MHz}$$

8. Calculate the VCO center-of-range frequency, f_{VRS} . The center-of-range frequency is the midpoint between the minimum and maximum frequencies attainable by the PLL.

$$f_{\text{VRS}} = L \times f_{\text{NOM}}$$

$$\text{Example: } f_{\text{VRS}} = 7 \times 4.9152 \text{ MHz} = 34.4 \text{ MHz}$$

For proper operation,

$$f_{\text{VRS}} - f_{\text{VCLK}} \leq \frac{f_{\text{NOM}}}{2}$$

CAUTION: Exceeding the recommended maximum bus frequency or VCO frequency can crash the MCU.

9. Program the PLL registers accordingly:
 - a. In the upper four bits of the PLL programming register (PPG), program the binary equivalent of N.
 - b. In the lower four bits of the PLL programming register (PPG), program the binary equivalent of L.

4.3.2.5 Special Programming Exceptions

The programming method described in [4.3.2.4 Programming the PLL](#) does not account for possible exceptions. A value of 0 for N or L is meaningless when used in the equations given. To account for these exceptions:

- A 0 value for N is interpreted exactly the same as a value of 1.
- A 0 value for L disables the PLL and prevents its selection as the source for the base clock. See [4.3.3 Base Clock Selector Circuit](#).

4.3.3 Base Clock Selector Circuit

This circuit is used to select either the crystal clock, CGMXCLK, or the VCO clock, CGMVCLK, as the source of the base clock, CGMOUT. The two input clocks go through a transition control circuit that waits up to three CGMXCLK cycles and three CGMVCLK cycles to change from one clock source to the other. During this time, CGMOUT is held in stasis. The output of the transition control circuit is then divided by two to correct the duty cycle. Therefore, the bus clock frequency, which

is one-half of the base clock frequency, is one-fourth the frequency of the selected clock (CGMXCLK or CGMVCLK).

The BCS bit in the PLL control register (PCTL) selects which clock drives CGMOUT. The VCO clock cannot be selected as the base clock source if the PLL is not turned on. The PLL cannot be turned off if the VCO clock is selected. The PLL cannot be turned on or off simultaneously with the selection or deselection of the VCO clock. The VCO clock also cannot be selected as the base clock source if the factor L is programmed to a 0. This value would set up a condition inconsistent with the operation of the PLL, so that the PLL would be disabled and the crystal clock would be forced as the source of the base clock.

4.3.4 CGM External Connections

In its typical configuration, the CGM requires seven external components. Five of these are for the crystal oscillator and two are for the PLL.

The crystal oscillator is normally connected in a Pierce oscillator configuration, as shown in **Figure 4-3**. **Figure 4-3** shows only the logical representation of the internal components and may not represent actual circuitry.

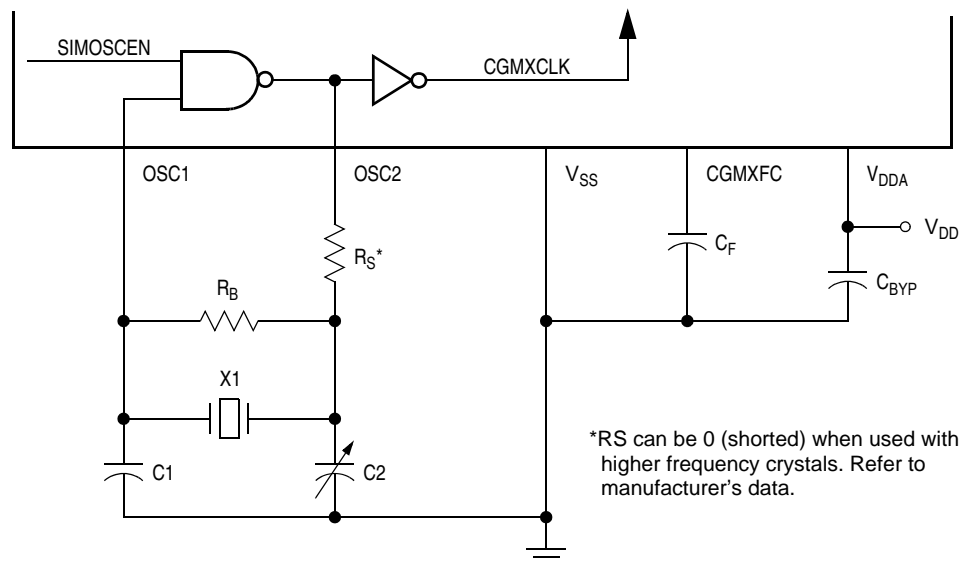

Figure 4-3. CGM External Connections

The oscillator configuration uses five components:

1. Crystal, X₁
2. Fixed capacitor, C₁
3. Tuning capacitor, C₂ (can also be a fixed capacitor)
4. Feedback resistor, R_B
5. Series resistor, R_S (optional)

The series resistor (R_S) is included in the diagram to follow strict Pierce oscillator guidelines and may not be required for all ranges of operation, especially with high-frequency crystals. Refer to the crystal manufacturer's data for more information.

Figure 4-3 also shows the external components for the PLL:

- Bypass capacitor, C_{BYP}
- Filter capacitor, C_F

NOTE: *Routing should be done with great care to minimize signal cross talk and noise. (See **4.8 Acquisition/Lock Time Specifications** for routing information and more information on the filter capacitor's value and its effects on PLL performance.)*

4.4 I/O Signals

This section describes the CGM input/output (I/O) signals.

4.4.1 Crystal Amplifier Input Pin (OSC1)

The OSC1 pin is an input to the crystal oscillator amplifier.

4.4.2 Crystal Amplifier Output Pin (OSC2)

The OSC2 pin is the output of the crystal oscillator inverting amplifier.

4.4.3 External Filter Capacitor Pin (CGMXFC)

The CGMXFC pin is required by the loop filter to filter out phase corrections. A small external capacitor is connected to this pin.

NOTE: *To prevent noise problems, C_F should be placed as close to the CGMXFC pin as possible, with minimum routing distances and no routing of other signals across the C_F connection.*

4.4.4 PLL Analog Power Pin (V_{DDA})

V_{DDA} is a power pin used by the analog portions of the PLL. Connect the V_{DDA} pin to the same voltage potential as the V_{DD} pin.

NOTE: *Route V_{DDA} carefully for maximum noise immunity and place bypass capacitors as close as possible to the package.*

4.4.5 Oscillator Enable Signal (SIMOSCEN)

The SIMOSCEN signal comes from the system integration module (SIM) and enables the oscillator and PLL.

4.4.6 Crystal Output Frequency Signal (CGMXCLK)

CGMXCLK is the crystal oscillator output signal. It runs at the full speed of the crystal (f_{XCLK}) and comes directly from the crystal oscillator circuit. [Figure 4-3](#) shows only the logical relation of CGMXCLK to OSC1 and OSC2 and may not represent the actual circuitry. The duty cycle of CGMXCLK is unknown and may depend on the crystal and other external factors. Also, the frequency and amplitude of CGMXCLK can be unstable at startup.

4.4.7 CGM Base Clock Output (CGMOUT)

CGMOUT is the clock output of the CGM. This signal goes to the SIM, which generates the MCU clocks. CGMOUT is a 50 percent duty cycle clock running at twice the bus frequency. CGMOUT is software programmable to be either the oscillator output, CGMXCLK, divided by two or the VCO clock, CGMVCLK, divided by two.

4.4.8 CGM CPU Interrupt (CGMINT)

CGMINT is the interrupt signal generated by the PLL lock detector.

4.5 CGM Registers

These registers control and monitor operation of the CGM:

- PLL control register (PCTL) — see [4.5.1 PLL Control Register](#)
- PLL bandwidth control register (PBWC) — see [4.5.2 PLL Bandwidth Control Register](#)
- PLL programming register (PPG) — see [4.5.3 PLL Programming Register](#)

[Figure 4-4](#) is a summary of the CGM registers.

Addr.	Register Name	Bit 7	6	5	4	3	2	1	Bit 0		
\$005C	PLL Control Register (PCTL) <i>See page 69.</i>	Read:	PLLIE	PLL F	PLLON	BCS	1	1	1	1	
		Write:		R			R	R	R	R	
		Reset:	0	0	1	0	1	1	1	1	
\$005D	PLL Bandwidth Control Register (PBWC) <i>See page 71.</i>	Read:	AUTO	LOCK	\overline{ACQ}	XLD	0	0	0	0	
		Write:		R			R	R	R	R	
		Reset:	0	0	0	0	0	0	0	0	
\$005E	PLL Programming Register (PPG) <i>See page 72.</i>	Read:	MUL7	MUL6	MUL5	MUL4	VRS7	VRS6	VRS5	VRS4	
		Write:									
		Reset:	0	1	1	0	0	1	1	0	

R = Reserved

Notes:

1. When AUTO = 0, PLLIE is forced to logic 0 and is read-only.
2. When AUTO = 0, PLL F and LOCK read as logic 0.
3. When AUTO = 1, \overline{ACQ} is read-only.
4. When PLLON = 0 or VRS[7:4] = \$0, BCS is forced to logic 0 and is read-only.
5. When PLLON = 1, the PLL programming register is read-only.
6. When BCS = 1, PLLON is forced set and is read-only.

Figure 4-4. CGM I/O Register Summary

4.5.1 PLL Control Register

The PLL control register (PCTL) contains the interrupt enable and flag bits, the on/off switch, and the base clock selector bit.

Address: \$005C

	Bit 7	6	5	4	3	2	1	Bit 0
Read:	PLLIE	PLL F	PLLON	BCS	1	1	1	1
Write:		R			R	R	R	R
Reset:	0	0	1	0	1	1	1	1

R = Reserved

Figure 4-5. PLL Control Register (PCTL)

PLLIE — PLL Interrupt Enable Bit

This read/write bit enables the PLL to generate an interrupt request when the LOCK bit toggles, setting the PLL flag, PLL F. When the AUTO bit in the PLL bandwidth control register (PBWC) is clear, PLLIE cannot be written and reads as logic 0. Reset clears the PLLIE bit.

- 1 = PLL interrupts enabled
- 0 = PLL interrupts disabled

PLL F — PLL Interrupt Flag

This read-only bit is set whenever the LOCK bit toggles. PLL F generates an interrupt request if the PLLIE bit also is set. PLL F always reads as logic 0 when

the AUTO bit in the PLL bandwidth control register (PBWC) is clear. Clear the PLLF bit by reading the PLL control register. Reset clears the PLLF bit.

- 1 = Change in lock condition
- 0 = No change in lock condition

NOTE: Do not inadvertently clear the PLLF bit. Any read or read-modify-write operation on the PLL control register clears the PLLF bit.

PLLON — PLL On Bit

This read/write bit activates the PLL and enables the VCO clock, CGMVCLK. PLLON cannot be cleared if the VCO clock is driving the base clock, CGMOUT (BCS = 1). See [4.3.3 Base Clock Selector Circuit](#). Reset sets this bit so that the loop can stabilize as the MCU is powering up.

- 1 = PLL on
- 0 = PLL off

BCS — Base Clock Select Bit

This read/write bit selects either the crystal oscillator output, CGMXCLK, or the VCO clock, CGMVCLK, as the source of the CGM output, CGMOUT. CGMOUT frequency is one-half the frequency of the selected clock. BCS cannot be set while the PLLON bit is clear. After toggling BCS, it may take up to three CGMXCLK and three CGMVCLK cycles to complete the transition from one source clock to the other. During the transition, CGMOUT is held in stasis. See [4.3.3 Base Clock Selector Circuit](#). Reset clears the BCS bit.

- 1 = CGMVCLK divided by two drives CGMOUT
- 0 = CGMXCLK divided by two drives CGMOUT

NOTE: PLLON and BCS have built-in protection that prevents the base clock selector circuit from selecting the VCO clock as the source of the base clock if the PLL is off. Therefore, PLLON cannot be cleared when BCS is set, and BCS cannot be set when PLLON is clear. If the PLL is off (PLLON = 0), selecting CGMVCLK requires two writes to the PLL control register. See [4.3.3 Base Clock Selector Circuit](#).

PCTL[3:0] — Unimplemented Bits

These bits provide no function and always read as logic 1s.

4.5.2 PLL Bandwidth Control Register

The PLL bandwidth control register (PBWC):

- Selects automatic or manual (software-controlled) bandwidth control mode
- Indicates when the PLL is locked
- In automatic bandwidth control mode, indicates when the PLL is in acquisition or tracking mode
- In manual operation, forces the PLL into acquisition or tracking mode

Address: \$005D

	Bit 7	6	5	4	3	2	1	Bit 0
Read:	AUTO	LOCK	\overline{ACQ}	XLD	0	0	0	0
Write:		R			R	R	R	R
Reset:	0	0	0	0	0	0	0	0

R = Reserved

Figure 4-6. PLL Bandwidth Control Register (PBWC)

AUTO — Automatic Bandwidth Control Bit

This read/write bit selects automatic or manual bandwidth control. When initializing the PLL for manual operation (AUTO = 0), clear the \overline{ACQ} bit before turning on the PLL. Reset clears the AUTO bit.

- 1 = Automatic bandwidth control
- 0 = Manual bandwidth control

LOCK — Lock Indicator Bit

When the AUTO bit is set, LOCK is a read-only bit that becomes set when the VCO clock, CGMVCLK, is locked (running at the programmed frequency). When the AUTO bit is clear, LOCK reads as logic 0 and has no meaning. Reset clears the LOCK bit.

- 1 = VCO frequency correct or locked
- 0 = VCO frequency incorrect or unlocked

\overline{ACQ} — Acquisition Mode Bit

When the AUTO bit is set, \overline{ACQ} is a read-only bit that indicates whether the PLL is in acquisition mode or tracking mode. When the AUTO bit is clear, \overline{ACQ} is a read/write bit that controls whether the PLL is in acquisition or tracking mode. In automatic bandwidth control mode (AUTO = 1), the last-written value from manual operation is stored in a temporary location and is recovered when manual operation resumes. Reset clears this bit, enabling acquisition mode.

- 1 = Tracking mode
- 0 = Acquisition mode

XLD — Crystal Loss Detect Bit

When the VCO output, CGMVCLK, is driving CGMOUT, this read/write bit can indicate whether the crystal reference frequency is active or not. To check the status of the crystal reference, follow these steps:

1. Write a logic 1 to XLD.
2. Wait $N \times 4$ cycles. (N is the VCO frequency multiplier.)
3. Read XLD.

The crystal loss detect function works only when the BCS bit is set, selecting CGMVCLK to drive CGMOUT. When BCS is clear, XLD always reads as logic 0.

- 1 = Crystal reference is not active.
- 0 = Crystal reference is active.

PBWC[3:0] — Reserved for Test

These bits enable test functions not available in user mode. To ensure software portability from development systems to user applications, software should write 0s to PBWC[3:0] whenever writing to PBWC.

4.5.3 PLL Programming Register

The PLL programming register (PPG) contains the programming information for the modulo feedback divider and the programming information for the hardware configuration of the VCO.

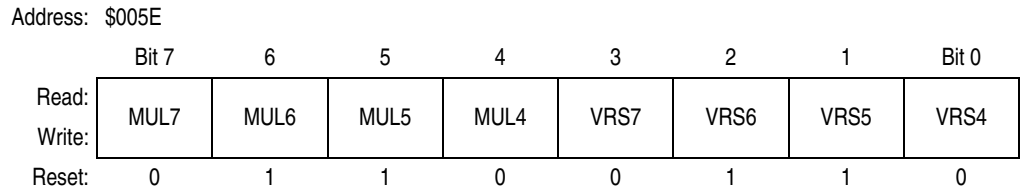

Figure 4-7. PLL Programming Register (PPG)

MUL[7:4] — Multiplier Select Bits

These read/write bits control the modulo feedback divider that selects the VCO frequency multiplier, N. See 4.3.2.1 PLL Circuits and 4.3.2.4 Programming the PLL. A value of \$0 in the multiplier select bits configures the modulo feedback divider the same as a value of \$1. Reset initializes these bits to \$6 to give a default multiply value of 6.

Table 4-2. VCO Frequency Multiplier (N) Selection

MUL7:MUL6:MUL5:MUL4	VCO Frequency Multiplier (N)
0000	1
0001	1
0010	2
0011	3
↓	↓
1101	13
1110	14
1111	15

NOTE: The multiplier select bits have built-in protection that prevents them from being written when the PLL is on (PLLON = 1).

VRS[7:4] — VCO Range Select Bits

These read/write bits control the hardware center-of-range linear multiplier L, which controls the hardware center-of-range frequency f_{VRS} . See 4.3.2.1 PLL Circuits, 4.3.2.4 Programming the PLL and 4.5.1 PLL Control Register. VRS[7:4] cannot be written when the PLLON bit in the PLL control register

(PCTL) is set. See [4.3.2.5 Special Programming Exceptions](#). A value of \$0 in the VCO range select bits disables the PLL and clears the BCS bit in the PCTL. See [4.3.3 Base Clock Selector Circuit](#) and [4.3.2.5 Special Programming Exceptions](#) for more information.

Reset initializes the bits to \$6 to give a default range multiply value of 6.

NOTE: *The VCO range select bits have built-in protection that prevents them from being written when the PLL is on ($PLLON = 1$) and prevents selection of the VCO clock as the source of the base clock ($BCS = 1$) if the VCO range select bits are all clear.*

The VCO range select bits must be programmed correctly. Incorrect programming may result in failure of the PLL to achieve lock.

4.6 Interrupts

When the AUTO bit is set in the PLL bandwidth control register (PBWC), the PLL can generate a CPU interrupt request every time the LOCK bit changes state. The PLLIE bit in the PLL control register (PCTL) enables CPU interrupts from the PLL. PLLF, the interrupt flag in the PCTL, becomes set whether interrupts are enabled or not. When the AUTO bit is clear, CPU interrupts from the PLL are disabled and PLLF reads as logic 0.

Software should read the LOCK bit after a PLL interrupt request to see if the request was due to an entry into lock or an exit from lock. When the PLL enters lock, the VCO clock, CGMVCLK, divided by two can be selected as the CGMOUT source by setting BCS in the PCTL. When the PLL exits lock, the VCO clock frequency is corrupt, and appropriate precautions should be taken. If the application is not frequency-sensitive, interrupts should be disabled to prevent PLL interrupt service routines from impeding software performance or from exceeding stack limitations.

NOTE: *Software can select the CGMVCLK divided by two as the CGMOUT source even if the PLL is not locked ($LOCK = 0$). Therefore, software should make sure the PLL is locked before setting the BCS bit.*

4.7 Wait Mode

The WAIT instruction puts the MCU in low power-consumption standby mode.

The WAIT instruction does not affect the CGM. Before entering wait mode, software can disengage and turn off the PLL by clearing the BCS and PLLON bits in the PLL control register (PCTL). Less power-sensitive applications can disengage the PLL without turning it off. Applications that require the PLL to wake the MCU from wait mode also can deselect the PLL output without turning off the PLL.

4.8 Acquisition/Lock Time Specifications

The acquisition and lock times of the PLL are, in many applications, the most critical PLL design parameters. Proper design and use of the PLL ensures the highest stability and lowest acquisition/lock times.

4.8.1 Acquisition/Lock Time Definitions

Typical control systems refer to the acquisition time or lock time as the reaction time, within specified tolerances, of the system to a step input. In a PLL, the step input occurs when the PLL is turned on or when it suffers a noise hit. The tolerance is usually specified as a percent of the step input or when the output settles to the desired value plus or minus a percent of the frequency change. Therefore, the reaction time is constant in this definition, regardless of the size of the step input. For example, consider a system with a 5 percent acquisition time tolerance. If a command instructs the system to change from 0 Hz to 1 MHz, the acquisition time is the time taken for the frequency to reach $1\text{ MHz} \pm 50\text{ kHz}$. Fifty kHz = 5% of the 1-MHz step input. If the system is operating at 1 MHz and suffers a -100-kHz noise hit, the acquisition time is the time taken to return from 900 kHz to $1\text{ MHz} \pm 5\text{ kHz}$. Five kHz = 5% of the 100-kHz step input.

Other systems refer to acquisition and lock times as the time the system takes to reduce the error between the actual output and the desired output to within specified tolerances. Therefore, the acquisition or lock time varies according to the original error in the output. Minor errors may not even be registered. Typical PLL applications prefer to use this definition because the system requires the output frequency to be within a certain tolerance of the desired frequency regardless of the size of the initial error.

The discrepancy in these definitions makes it difficult to specify an acquisition or lock time for a typical PLL. Therefore, the definitions for acquisition and lock times for this module are:

- Acquisition time, t_{ACQ} , is the time the PLL takes to reduce the error between the actual output frequency and the desired output frequency to less than the tracking mode entry tolerance, Δ_{TRK} . Acquisition time is based on an initial frequency error, $(f_{DES} - f_{ORIG})/f_{DES}$, of not more than ± 100 percent. In automatic bandwidth control mode (see [4.3.2.3 Manual and Automatic PLL Bandwidth Modes](#)), acquisition time expires when the ACQ bit becomes set in the PLL bandwidth control register (PBWC).
- Lock time, t_{LOCK} , is the time the PLL takes to reduce the error between the actual output frequency and the desired output frequency to less than the lock mode entry tolerance, Δ_{LOCK} . Lock time is based on an initial frequency error, $(f_{DES} - f_{ORIG})/f_{DES}$, of not more than ± 100 percent. In automatic bandwidth control mode, lock time expires when the LOCK bit becomes set in the PLL bandwidth control register (PBWC). See [4.3.2.3 Manual and Automatic PLL Bandwidth Modes](#).

Obviously, the acquisition and lock times can vary according to how large the frequency error is and may be shorter or longer in many cases.

4.8.2 Parametric Influences on Reaction Time

Acquisition and lock times are designed to be as short as possible while still providing the highest possible stability. These reaction times are not constant, however. Many factors directly and indirectly affect the acquisition time.

The most critical parameter which affects the reaction times of the PLL is the reference frequency, f_{RDV} . This frequency is the input to the phase detector and controls how often the PLL makes corrections. For stability, the corrections must be small compared to the desired frequency, so several corrections are required to reduce the frequency error. Therefore, the slower the reference the longer it takes to make these corrections. This parameter is also under user control via the choice of crystal frequency, f_{XCLK} .

Another critical parameter is the external filter capacitor. The PLL modifies the voltage on the VCO by adding or subtracting charge from this capacitor. Therefore, the rate at which the voltage changes for a given frequency error (thus change in charge) is proportional to the capacitor size. The size of the capacitor also is related to the stability of the PLL. If the capacitor is too small, the PLL cannot make small enough adjustments to the voltage and the system cannot lock. If the capacitor is too large, the PLL may not be able to adjust the voltage in a reasonable time. See [4.8.3 Choosing a Filter Capacitor](#).

Also important is the operating voltage potential applied to V_{DDA} . The power supply potential alters the characteristics of the PLL. A fixed value is best. Variable supplies, such as batteries, are acceptable if they vary within a known range at very slow speeds. Noise on the power supply is not acceptable, because it causes small frequency errors which continually change the acquisition time of the PLL.

Temperature and processing also can affect acquisition time because the electrical characteristics of the PLL change. The part operates as specified as long as these influences stay within the specified limits. External factors, however, can cause drastic changes in the operation of the PLL. These factors include noise injected into the PLL through the filter capacitor filter, capacitor leakage, stray impedances on the circuit board, and even humidity or circuit board contamination.

4.8.3 Choosing a Filter Capacitor

As described in [4.8.2 Parametric Influences on Reaction Time](#), the external filter capacitor, C_F , is critical to the stability and reaction time of the PLL. The PLL is also dependent on reference frequency and supply voltage. The value of the capacitor must, therefore, be chosen with supply potential and reference frequency in mind.

For proper operation, the external filter capacitor must be chosen according to this equation:

$$C_F = C_{FACT} \left(\frac{V_{DDA}}{f_{RDV}} \right)$$

For acceptable values of C_{FACT} , see [4.8 Acquisition/Lock Time Specifications](#). For the value of V_{DDA} , choose the voltage potential at which the MCU is operating. If the power supply is variable, choose a value near the middle of the range of possible supply values.

This equation does not always yield a commonly available capacitor size, so round to the nearest available size. If the value is between two different sizes, choose the higher value for better stability. Choosing the lower size may seem attractive for acquisition time improvement, but the PLL can become unstable. Also, always choose a capacitor with a tight tolerance (± 20 percent or better) and low dissipation.

4.8.4 Reaction Time Calculation

The actual acquisition and lock times can be calculated using the equations here. These equations yield nominal values under these conditions:

- Correct selection of filter capacitor, C_F , see [4.8.3 Choosing a Filter Capacitor](#)
- Room temperature operation
- Negligible external leakage on C_{GMXFC}
- Negligible noise

The K factor in the equations is derived from internal PLL parameters. K_{ACQ} is the K factor when the PLL is configured in acquisition mode, and K_{TRK} is the K factor when the PLL is configured in tracking mode. See [4.3.2.2 Acquisition and Tracking Modes](#).

$$t_{ACQ} = \left(\frac{V_{DDA}}{f_{RDV}} \right) \left(\frac{8}{K_{ACQ}} \right)$$

$$t_{AL} = \left(\frac{V_{DDA}}{f_{RDV}} \right) \left(\frac{4}{K_{TRK}} \right)$$

$$t_{Lock} = t_{ACQ} + t_{AL}$$

NOTE: *The inverse proportionality between the lock time and the reference frequency.*

In automatic bandwidth control mode, the acquisition and lock times are quantized into units based on the reference frequency. See [4.3.2.3 Manual and Automatic PLL Bandwidth Modes](#). A certain number of clock cycles, n_{ACQ} , is required to ascertain that the PLL is within the tracking mode entry tolerance, Δ_{TRK} , before

exiting acquisition mode. A certain number of clock cycles, n_{TRK} , is required to ascertain that the PLL is within the lock mode entry tolerance, Δ_{Lock} . Therefore, the acquisition time, t_{ACQ} , is an integer multiple of n_{ACQ}/f_{RDV} , and the acquisition to lock time, t_{AL} , is an integer multiple of n_{TRK}/f_{RDV} . Also, since the average frequency over the entire measurement period must be within the specified tolerance, the total time usually is longer than t_{Lock} as calculated in the previous example.

In manual mode, it is usually necessary to wait considerably longer than t_{Lock} before selecting the PLL clock (see [4.3.3 Base Clock Selector Circuit](#)) because the factors described in [4.8.2 Parametric Influences on Reaction Time](#) may slow the lock time considerably.

Section 5. Configuration Register (CONFIG)

5.1 Introduction

This section describes the configuration register (CONFIG). This register contains bits that configure these options:

- Resets caused by the low-voltage inhibit (LVI) module
- Power to the LVI module
- Computer operating properly (COP) module
- Top-side pulse-width modulator (PWM) polarity
- Bottom-side PWM polarity
- Edge-aligned versus center-aligned PWMs
- Six independent PWMs versus three complementary PWM pairs

5.2 Functional Description

The configuration register (CONFIG) is used in the initialization of various options. The configuration register can be written once after each reset. All of the configuration register bits are cleared during reset. Since the various options affect the operation of the microcontroller unit (MCU), it is recommended that this register be written immediately after reset. The configuration register is located at \$001F and may be read at anytime.

NOTE: *On a FLASH device, the options are one-time writeable by the user after each reset. The registers are not in the FLASH memory but are special registers containing one-time writeable latches after each reset. Upon a reset, the configuration register defaults to predetermined settings as shown in [Figure 5-1](#).*

If the LVI module and the LVI reset signal are enabled, a reset occurs when V_{DD} falls to a voltage, V_{LVRX} , and remains at or below that level for at least nine consecutive central processor unit (CPU) cycles. Once an LVI reset occurs, the MCU remains in reset until V_{DD} rises to a voltage, V_{LVRX} .

Configuration Register (CONFIG)

5.3 Configuration Register

Address: \$001F

	Bit 7	6	5	4	3	2	1	Bit 0
Read:	EDGE	BOTNEG	TOPNEG	INDEP	LVIRST	LVIPWR	STOPE	COPD
Write:								
Reset:	0	0	0	0	1	1	0	0

Figure 5-1. Configuration Register (CONFIG)

EDGE — Edge-Align Enable Bit

EDGE determines if the motor control PWM will operate in edge-aligned mode or center-aligned mode. See [Section 12. Pulse-Width Modulator for Motor Control \(PWMMC\)](#).

- 1 = Edge-aligned mode enabled
- 0 = Center-aligned mode enabled

BOTNEG — Bottom-Side PWM Polarity Bit

BOTNEG determines if the bottom-side PWMs will have positive or negative polarity. See [Section 12. Pulse-Width Modulator for Motor Control \(PWMMC\)](#).

- 1 = Negative polarity
- 0 = Positive polarity

TOPNEG — Top-Side PWM Polarity Bit

TOPNEG determines if the top-side PWMs will have positive or negative polarity. See [Section 12. Pulse-Width Modulator for Motor Control \(PWMMC\)](#).

- 1 = Negative polarity
- 0 = Positive polarity

INDEP — Independent Mode Enable Bit

INDEP determines if the motor control PWMs will be six independent PWMs or three complementary PWM pairs. See [Section 12. Pulse-Width Modulator for Motor Control \(PWMMC\)](#).

- 1 = Six independent PWMs
- 0 = Three complementary PWM pairs

LVIRST — LVI Reset Enable Bit

LVIRST enables the reset signal from the LVI module. See [Section 9. Low-Voltage Inhibit \(LVI\)](#).

- 1 = LVI module resets enabled
- 0 = LVI module resets disabled

LVIPWR — LVI Power Enable Bit

LVIPWR enables the LVI module. See [Section 9. Low-Voltage Inhibit \(LVI\)](#).

- 1 = LVI module power enabled
- 0 = LVI module power disabled

STOPE — Stop Enable Bit

Writing a 0 or a 1 to bit 1 has no effect on MCU operation. Bit 1 operates the same as the other bits within this write-once register operate.

1 = STOP mode enabled

0 = STOP mode disabled

COPD — COP Disable Bit

COPD disables the COP module. See [Section 6. Computer Operating Properly \(COP\)](#).

1 = COP module disabled

0 = COP module enabled

Section 6. Computer Operating Properly (COP)

6.1 Introduction

This section describes the computer operating properly module, a free-running counter that generates a reset if allowed to overflow. The computer operating properly (COP) module helps software recover from runaway code. Prevent a COP reset by periodically clearing the COP counter.

6.2 Functional Description

Figure 6-1 shows the structure of the COP module. A summary of the input/output (I/O) register is shown in Figure 6-2.

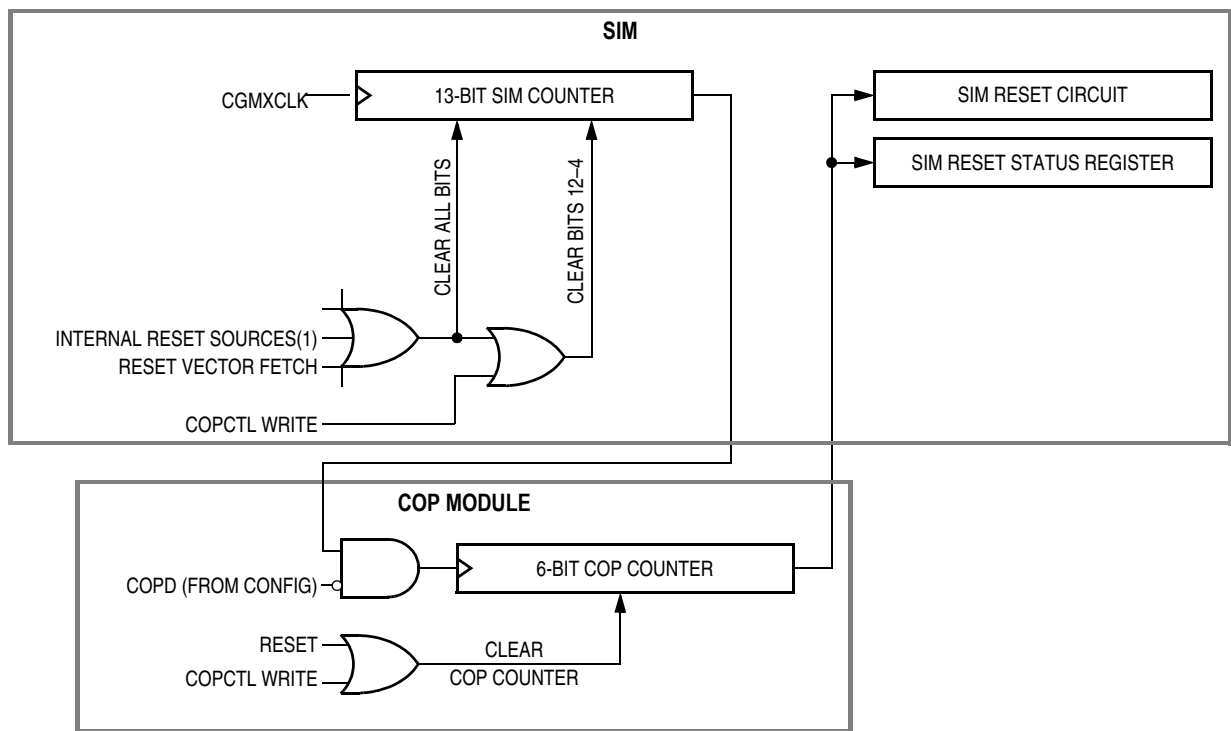

Note 1. See 14.3.2 Active Resets from Internal Sources.

Figure 6-1. COP Block Diagram

Computer Operating Properly (COP)

Addr.	Register Name	Bit 7	6	5	4	3	2	1	Bit 0	
\$FFFF	COP Control Register (COPCTL) See page 85.	Read:	Low byte of reset vector							
		Write:	Clear COP counter							
		Reset:	Unaffected by reset							

Figure 6-2. COP I/O Register Summary

The COP counter is a free-running, 6-bit counter preceded by the 13-bit system integration module (SIM) counter. If not cleared by software, the COP counter overflows and generates an asynchronous reset after $2^{18}-2^4$ CGMXCLK cycles. With a 4.9152-MHz crystal, the COP timeout period is 53.3 ms. Writing any value to location \$FFFF before overflow occurs clears the COP counter and prevents reset.

A COP reset pulls the \overline{RST} pin low for 32 CGMXCLK cycles and sets the COP bit in the SIM reset status register (SRSR). See [14.7.2 SIM Reset Status Register](#).

NOTE: Place COP clearing instructions in the main program and not in an interrupt subroutine. Such an interrupt subroutine could keep the COP from generating a reset even while the main program is not working properly.

6.3 I/O Signals

This section describes the signals shown in [Figure 6-1](#).

6.3.1 CGMXCLK

CGMXCLK is the crystal oscillator output signal. CGMXCLK frequency is equal to the crystal frequency.

6.3.2 COPCTL Write

Writing any value to the COP control register (COPCTL) (see [6.4 COP Control Register](#)) clears the COP counter and clears bits 12–4 of the SIM counter. Reading the COP control register returns the reset vector.

6.3.3 Power-On Reset

The power-on reset (POR) circuit in the SIM clears the SIM counter 4096 CGMXCLK cycles after power-up.

6.3.4 Internal Reset

An internal reset clears the SIM counter and the COP counter.

6.3.5 Reset Vector Fetch

A reset vector fetch occurs when the vector address appears on the data bus. A reset vector fetch clears the SIM counter.

6.3.6 COPD (COP Disable)

The COPD signal reflects the state of the COP disable bit (COPD) in the configuration register (CONFIG). See [Section 5. Configuration Register \(CONFIG\)](#).

6.4 COP Control Register

The COP control register is located at address \$FFFF and overlaps the reset vector. Writing any value to \$FFFF clears the COP counter and starts a new timeout period. Reading location \$FFFF returns the low byte of the reset vector.

Address:	\$FFFF
	Bit 7 6 5 4 3 2 1 Bit 0
Read:	Low byte of reset vector
Write:	Clear COP counter
Reset:	Unaffected by reset

Figure 6-3. COP Control Register (COPCTL)

6.5 Interrupts

The COP does not generate CPU interrupt requests.

6.6 Monitor Mode

The COP is disabled in monitor mode when V_{HI} is present on the \overline{IRQ} pin or on the \overline{RST} pin.

6.7 Wait Mode

The WAIT instruction puts the MCU in low power-consumption standby mode.

The COP continues to operate during wait mode.

6.8 Stop Mode

Stop mode turns off the CGMXCLK input to the COP and clears the COP prescaler. Service the COP immediately before entering or after exiting stop mode to ensure a full COP timeout period after entering or exiting stop mode.

Section 7. Central Processor Unit (CPU)

7.1 Introduction

This section describes the central processor unit (CPU08, version A). The M68HC08 CPU is an enhanced and fully object-code-compatible version of the M68HC05 CPU. The *CPU08 Reference Manual*, Motorola document order number CPU08RM/AD, contains a description of the CPU instruction set, addressing modes, and architecture.

7.2 Features

Features of the CPU08 include:

- Fully upward, object-code compatibility with M68HC05 Family
- 16-bit stack pointer with stack manipulation instructions
- 16-bit index register with X-register manipulation instructions
- 8-MHz CPU internal bus frequency
- 64-Kbyte program/data memory space
- 16 addressing modes
- Memory-to-memory data moves without using accumulator
- Fast 8-bit by 8-bit multiply and 16-bit by 8-bit divide instructions
- Enhanced binary-coded decimal (BCD) data handling
- Modular architecture with expandable internal bus definition for extension of addressing range beyond 64 Kbytes
- Low-power wait mode

7.3 CPU Registers

Figure 7-1 shows the five CPU registers. CPU registers are not part of the memory map.

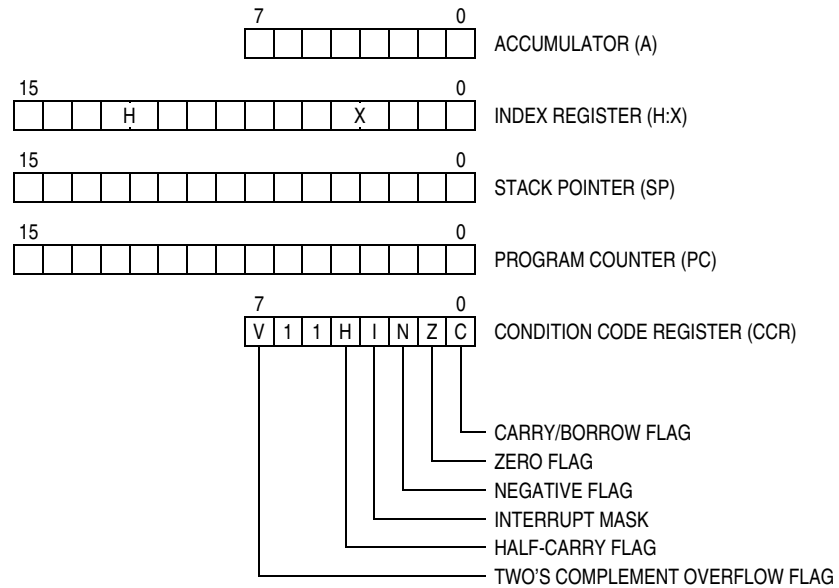

Figure 7-1. CPU Registers

7.3.1 Accumulator

The accumulator is a general-purpose 8-bit register. The CPU uses the accumulator to hold operands and the results of arithmetic/logic operations.

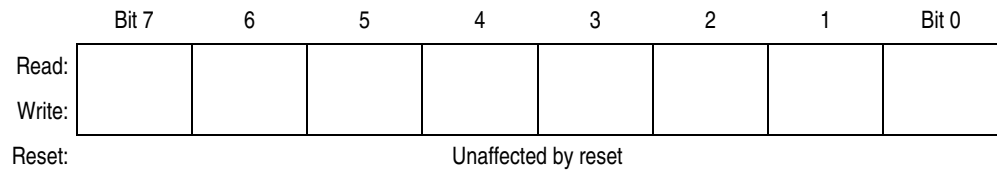

Figure 7-2. Accumulator (A)

7.3.2 Index Register

The 16-bit index register allows indexed addressing of a 64-Kbyte memory space. H is the upper byte of the index register, and X is the lower byte. H:X is the concatenated 16-bit index register.

In the indexed addressing modes, the CPU uses the contents of the index register to determine the conditional address of the operand.

The index register can serve also as a temporary data storage location.

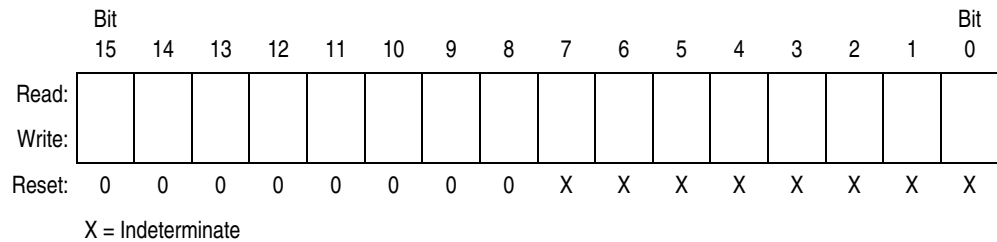

Figure 7-3. Index Register (H:X)

7.3.3 Stack Pointer

The stack pointer is a 16-bit register that contains the address of the next location on the stack. During a reset, the stack pointer is preset to \$00FF. The reset stack pointer (RSP) instruction sets the least significant byte to \$FF and does not affect the most significant byte. The stack pointer decrements as data is pushed onto the stack and increments as data is pulled from the stack.

In the stack pointer 8-bit offset and 16-bit offset addressing modes, the stack pointer can function as an index register to access data on the stack. The CPU uses the contents of the stack pointer to determine the conditional address of the operand.

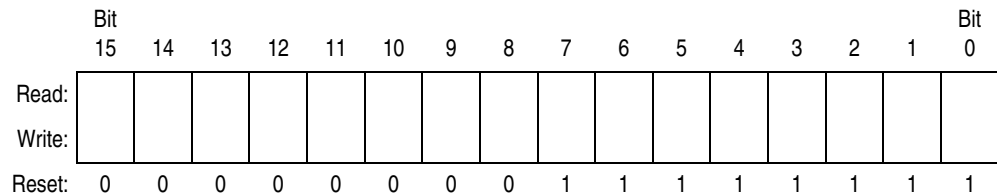

Figure 7-4. Stack Pointer (SP)

NOTE: The location of the stack is arbitrary and may be relocated anywhere in random-access memory (RAM). Moving the SP out of page 0 (\$0000 to \$00FF) frees direct address (page 0) space. For correct operation, the stack pointer must point only to RAM locations.

7.3.4 Program Counter

The program counter is a 16-bit register that contains the address of the next instruction or operand to be fetched.

Normally, the program counter automatically increments to the next sequential memory location every time an instruction or operand is fetched. Jump, branch, and interrupt operations load the program counter with an address other than that of the next sequential location.

During reset, the program counter is loaded with the reset vector address located at \$FFFE and \$FFFF. The vector address is the address of the first instruction to be executed after exiting the reset state.

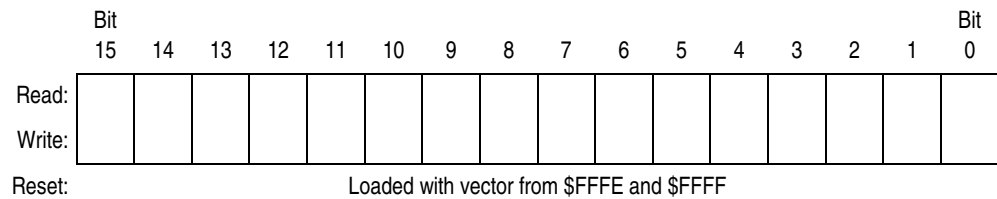

Figure 7-5. Program Counter (PC)

7.3.5 Condition Code Register

The 8-bit condition code register contains the interrupt mask and five flags that indicate the results of the instruction just executed. Bits 6 and 5 are set permanently to 1. The following paragraphs describe the functions of the condition code register.

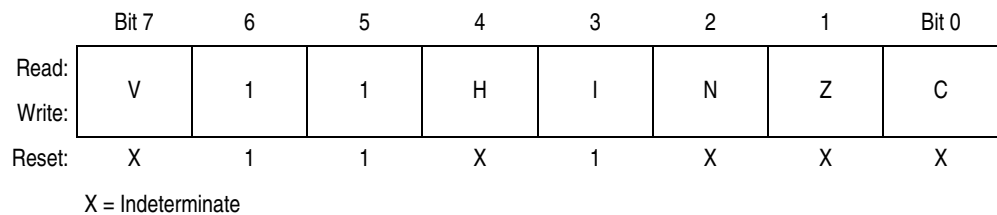

Figure 7-6. Condition Code Register (CCR)

V — Overflow Flag

The CPU sets the overflow flag when a two's complement overflow occurs. The signed branch instructions BGT, BGE, BLE, and BLT use the overflow flag.

1 = Overflow

0 = No overflow

H — Half-Carry Flag

The CPU sets the half-carry flag when a carry occurs between accumulator bits 3 and 4 during an add-without-carry (ADD) or add-with-carry (ADC) operation. The half-carry flag is required for binary-coded decimal (BCD) arithmetic operations. The DAA instruction uses the states of the H and C flags to determine the appropriate correction factor.

- 1 = Carry between bits 3 and 4
- 0 = No carry between bits 3 and 4

I — Interrupt Mask

When the interrupt mask is set, all maskable CPU interrupts are disabled. CPU interrupts are enabled when the interrupt mask is cleared. When a CPU interrupt occurs, the interrupt mask is set automatically after the CPU registers are saved on the stack, but before the interrupt vector is fetched.

- 1 = Interrupts disabled
- 0 = Interrupts enabled

NOTE: *To maintain M6805 Family compatibility, the upper byte of the index register (H) is not stacked automatically. If the interrupt service routine modifies H, then the user must stack and unstack H using the PSHH and PULH instructions.*

After the I bit is cleared, the highest-priority interrupt request is serviced first. A return-from-interrupt (RTI) instruction pulls the CPU registers from the stack and restores the interrupt mask from the stack. After any reset, the interrupt mask is set and can be cleared only by the clear interrupt mask software instruction (CLI).

N — Negative flag

The CPU sets the negative flag when an arithmetic operation, logic operation, or data manipulation produces a negative result, setting bit 7 of the result.

- 1 = Negative result
- 0 = Non-negative result

Z — Zero flag

The CPU sets the zero flag when an arithmetic operation, logic operation, or data manipulation produces a result of \$00.

- 1 = Zero result
- 0 = Non-zero result

C — Carry/Borrow Flag

The CPU sets the carry/borrow flag when an addition operation produces a carry out of bit 7 of the accumulator or when a subtraction operation requires a borrow. Some instructions — such as bit test and branch, shift, and rotate — also clear or set the carry/borrow flag.

- 1 = Carry out of bit 7
- 0 = No carry out of bit 7

7.4 Arithmetic/Logic Unit (ALU)

The ALU performs the arithmetic and logic operations defined by the instruction set.

Refer to the *CPU08 Reference Manual* (Motorola document order number CPU08RM/AD) for a description of the instructions and addressing modes and more detail about the architecture of the CPU.

7.5 Low-Power Modes

The WAIT and STOP instructions put the MCU in low power-consumption standby modes.

7.5.1 Wait Mode

The WAIT instruction:

- Clears the interrupt mask (I bit) in the condition code register, enabling interrupts. After exit from wait mode by interrupt, the I bit remains clear. After exit by reset, the I bit is set.
- Disables the CPU clock

7.5.2 Stop Mode

The STOP instruction:

- Clears the interrupt mask (I bit) in the condition code register, enabling external interrupts. After exit from stop mode by external interrupt, the I bit remains clear. After exit by reset, the I bit is set.
- Disables the CPU clock

After exiting stop mode, the CPU clock begins running after the oscillator stabilization delay.

7.6 CPU During Break Interrupts

If a break module is present on the MCU, the CPU starts a break interrupt by:

- Loading the instruction register with the SWI instruction
- Loading the program counter with \$FFFC:\$FFFD or with \$FEFC:\$FEFD in monitor mode

The break interrupt begins after completion of the CPU instruction in progress. If the break address register match occurs on the last cycle of a CPU instruction, the break interrupt begins immediately.

A return-from-interrupt instruction (RTI) in the break routine ends the break interrupt and returns the MCU to normal operation if the break interrupt has been deasserted.

7.7 Instruction Set Summary

Table 7-1 provides a summary of the M68HC08 instruction set.

Table 7-1. Instruction Set Summary (Sheet 1 of 7)

Source Form	Operation	Description	Effect on CCR					Address Mode	Opcode	Operand	Cycles	
			V	H	I	N	Z					C
ADC #opr ADC opr ADC opr ADC opr,X ADC opr,X ADC ,X ADC opr,SP ADC opr,SP	Add with Carry	$A \leftarrow (A) + (M) + (C)$	†	†	-	†	†	†	IMM DIR EXT IX2 IX1 IX SP1 SP2	A9 B9 C9 D9 E9 F9 9EE9 9ED9	ii dd hh ll ee ff ff ff ff ee ff	2 3 4 4 3 2 4 5
ADD #opr ADD opr ADD opr ADD opr,X ADD opr,X ADD ,X ADD opr,SP ADD opr,SP	Add without Carry	$A \leftarrow (A) + (M)$	†	†	-	†	†	IMM DIR EXT IX2 IX1 IX SP1 SP2	AB BB CB DB EB FB 9EEB 9EDB	ii dd hh ll ee ff ff ff ff ee ff	2 3 4 4 3 2 4 5	
AIS #opr	Add Immediate Value (Signed) to SP	$SP \leftarrow (SP) + (16 \ll M)$	-	-	-	-	-	IMM	A7	ii	2	
AIX #opr	Add Immediate Value (Signed) to H:X	$H:X \leftarrow (H:X) + (16 \ll M)$	-	-	-	-	-	IMM	AF	ii	2	
AND #opr AND opr AND opr AND opr,X AND opr,X AND ,X AND opr,SP AND opr,SP	Logical AND	$A \leftarrow (A) \& (M)$	0	-	-	†	†	IMM DIR EXT IX2 IX1 IX SP1 SP2	A4 B4 C4 D4 E4 F4 9EE4 9ED4	ii dd hh ll ee ff ff ff ff ee ff	2 3 4 4 3 2 4 5	
ASL opr ASLA ASLX ASL opr,X ASL ,X ASL opr,SP	Arithmetic Shift Left (Same as LSL)		†	-	-	†	†	DIR INH INH IX1 IX SP1	38 48 58 68 78 9E68	dd ff ff	4 1 1 4 3 5	
ASR opr ASRA ASRX ASR opr,X ASR opr,X ASR opr,SP	Arithmetic Shift Right		†	-	-	†	†	DIR INH INH IX1 IX SP1	37 47 57 67 77 9E67	dd ff ff	4 1 4 3 5	
BCC rel	Branch if Carry Bit Clear	$PC \leftarrow (PC) + 2 + rel ? (C) = 0$	-	-	-	-	-	REL	24	rr	3	
BCLR n, opr	Clear Bit n in M	$M_n \leftarrow 0$	-	-	-	-	-	DIR (b0) DIR (b1) DIR (b2) DIR (b3) DIR (b4) DIR (b5) DIR (b6) DIR (b7)	11 13 15 17 19 1B 1D 1F	dd dd dd dd dd dd dd dd	4 4 4 4 4 4 4 4	
BCS rel	Branch if Carry Bit Set (Same as BLO)	$PC \leftarrow (PC) + 2 + rel ? (C) = 1$	-	-	-	-	-	REL	25	rr	3	
BEQ rel	Branch if Equal	$PC \leftarrow (PC) + 2 + rel ? (Z) = 1$	-	-	-	-	-	REL	27	rr	3	

Table 7-1. Instruction Set Summary (Sheet 2 of 7)

Source Form	Operation	Description	Effect on CCR						Address Mode	Opcode	Operand	Cycles
			V	H	I	N	Z	C				
BGE <i>opr</i>	Branch if Greater Than or Equal To (Signed Operands)	$PC \leftarrow (PC) + 2 + rel ? (N \oplus V) = 0$	-	-	-	-	-	-	REL	90	rr	3
BGT <i>opr</i>	Branch if Greater Than (Signed Operands)	$PC \leftarrow (PC) + 2 + rel ? (Z) (N \oplus V) = 0$	-	-	-	-	-	-	REL	92	rr	3
BHCC <i>rel</i>	Branch if Half Carry Bit Clear	$PC \leftarrow (PC) + 2 + rel ? (H) = 0$	-	-	-	-	-	-	REL	28	rr	3
BHCS <i>rel</i>	Branch if Half Carry Bit Set	$PC \leftarrow (PC) + 2 + rel ? (H) = 1$	-	-	-	-	-	-	REL	29	rr	3
BHI <i>rel</i>	Branch if Higher	$PC \leftarrow (PC) + 2 + rel ? (C) (Z) = 0$	-	-	-	-	-	-	REL	22	rr	3
BHS <i>rel</i>	Branch if Higher or Same (Same as BCC)	$PC \leftarrow (PC) + 2 + rel ? (C) = 0$	-	-	-	-	-	-	REL	24	rr	3
BIH <i>rel</i>	Branch if \overline{IRQ} Pin High	$PC \leftarrow (PC) + 2 + rel ? \overline{IRQ} = 1$	-	-	-	-	-	-	REL	2F	rr	3
BIL <i>rel</i>	Branch if \overline{IRQ} Pin Low	$PC \leftarrow (PC) + 2 + rel ? \overline{IRQ} = 0$	-	-	-	-	-	-	REL	2E	rr	3
BIT # <i>opr</i> BIT <i>opr</i> BIT <i>opr</i> BIT <i>opr,X</i> BIT <i>opr,X</i> BIT <i>X</i> BIT <i>opr,SP</i> BIT <i>opr,SP</i>	Bit Test	(A) & (M)	0	-	-	†	†	-	IMM DIR EXT IX2 IX1 IX SP1 SP2	A5 B5 C5 D5 E5 F5 9EE5 9ED5	ii dd hh ll ee ff ff ff ee ff	2 3 4 4 3 2 4 5
BLE <i>opr</i>	Branch if Less Than or Equal To (Signed Operands)	$PC \leftarrow (PC) + 2 + rel ? (Z) (N \oplus V) = 1$	-	-	-	-	-	-	REL	93	rr	3
BLO <i>rel</i>	Branch if Lower (Same as BCS)	$PC \leftarrow (PC) + 2 + rel ? (C) = 1$	-	-	-	-	-	-	REL	25	rr	3
BLS <i>rel</i>	Branch if Lower or Same	$PC \leftarrow (PC) + 2 + rel ? (C) (Z) = 1$	-	-	-	-	-	-	REL	23	rr	3
BLT <i>opr</i>	Branch if Less Than (Signed Operands)	$PC \leftarrow (PC) + 2 + rel ? (N \oplus V) = 1$	-	-	-	-	-	-	REL	91	rr	3
BMC <i>rel</i>	Branch if Interrupt Mask Clear	$PC \leftarrow (PC) + 2 + rel ? (I) = 0$	-	-	-	-	-	-	REL	2C	rr	3
BMI <i>rel</i>	Branch if Minus	$PC \leftarrow (PC) + 2 + rel ? (N) = 1$	-	-	-	-	-	-	REL	2B	rr	3
BMS <i>rel</i>	Branch if Interrupt Mask Set	$PC \leftarrow (PC) + 2 + rel ? (I) = 1$	-	-	-	-	-	-	REL	2D	rr	3
BNE <i>rel</i>	Branch if Not Equal	$PC \leftarrow (PC) + 2 + rel ? (Z) = 0$	-	-	-	-	-	-	REL	26	rr	3
BPL <i>rel</i>	Branch if Plus	$PC \leftarrow (PC) + 2 + rel ? (N) = 0$	-	-	-	-	-	-	REL	2A	rr	3
BRA <i>rel</i>	Branch Always	$PC \leftarrow (PC) + 2 + rel$	-	-	-	-	-	-	REL	20	rr	3
BRCLR <i>n,opr,rel</i>	Branch if Bit <i>n</i> in M Clear	$PC \leftarrow (PC) + 3 + rel ? (Mn) = 0$	-	-	-	-	-	†	DIR (b0) DIR (b1) DIR (b2) DIR (b3) DIR (b4) DIR (b5) DIR (b6) DIR (b7)	01 03 05 07 09 0B 0D 0F	dd rr dd rr dd rr dd rr dd rr dd rr dd rr dd rr	5 5 5 5 5 5 5 5
BRN <i>rel</i>	Branch Never	$PC \leftarrow (PC) + 2$	-	-	-	-	-	-	REL	21	rr	3

Table 7-1. Instruction Set Summary (Sheet 3 of 7)

Source Form	Operation	Description	Effect on CCR					Address Mode	Opcode	Operand	Cycles	
			V	H	I	N	Z					C
BRSET <i>n,opr,rel</i>	Branch if Bit <i>n</i> in M Set	$PC \leftarrow (PC) + 3 + rel ? (Mn) = 1$							DIR (b0)	00	dd rr	5
									DIR (b1)	02	dd rr	5
									DIR (b2)	04	dd rr	5
									DIR (b3)	06	dd rr	5
									DIR (b4)	08	dd rr	5
									DIR (b5)	0A	dd rr	5
									DIR (b6)	0C	dd rr	5
									DIR (b7)	0E	dd rr	5
BSET <i>n,opr</i>	Set Bit <i>n</i> in M	$Mn \leftarrow 1$							DIR (b0)	10	dd	4
									DIR (b1)	12	dd	4
									DIR (b2)	14	dd	4
									DIR (b3)	16	dd	4
									DIR (b4)	18	dd	4
									DIR (b5)	1A	dd	4
									DIR (b6)	1C	dd	4
									DIR (b7)	1E	dd	4
BSR <i>rel</i>	Branch to Subroutine	$PC \leftarrow (PC) + 2$; push (PCL) $SP \leftarrow (SP) - 1$; push (PCH) $SP \leftarrow (SP) - 1$ $PC \leftarrow (PC) + rel$	-	-	-	-	-	REL	AD	rr	4	
CBEQ <i>opr,rel</i> CBEQA # <i>opr,rel</i> CBEQX # <i>opr,rel</i> CBEQ <i>opr,X+,rel</i> CBEQ <i>X+,rel</i> CBEQ <i>opr,SP,rel</i>	Compare and Branch if Equal	$PC \leftarrow (PC) + 3 + rel ? (A) - (M) = \00 $PC \leftarrow (PC) + 3 + rel ? (A) - (M) = \00 $PC \leftarrow (PC) + 3 + rel ? (X) - (M) = \00 $PC \leftarrow (PC) + 3 + rel ? (A) - (M) = \00 $PC \leftarrow (PC) + 2 + rel ? (A) - (M) = \00 $PC \leftarrow (PC) + 4 + rel ? (A) - (M) = \00							DIR	31	dd rr	5
									IMM	41	ii rr	4
									IMM	51	ii rr	4
									IX1+	61	ff rr	5
									IX+	71	rr	4
									SP1	9E61	ff rr	6
CLC	Clear Carry Bit	$C \leftarrow 0$	-	-	-	-	-	INH	98		1	
CLI	Clear Interrupt Mask	$I \leftarrow 0$	-	-	0	-	-	INH	9A		2	
CLR <i>opr</i> CLRA CLR X CLR H CLR <i>opr,X</i> CLR ,X CLR <i>opr,SP</i>	Clear	$M \leftarrow \$00$ $A \leftarrow \$00$ $X \leftarrow \$00$ $H \leftarrow \$00$ $M \leftarrow \$00$ $M \leftarrow \$00$ $M \leftarrow \$00$							DIR	3F	dd	3
									INH	4F		1
									INH	5F		1
									INH	8C		1
									IX1	6F	ff	3
									IX	7F		2
									SP1	9E6F	ff	4
CMP # <i>opr</i> CMP <i>opr</i> CMP <i>opr</i> CMP <i>opr,X</i> CMP <i>opr,X</i> CMP ,X CMP <i>opr,SP</i> CMP <i>opr,SP</i>	Compare A with M	$(A) - (M)$							IMM	A1	ii	2
									DIR	B1	dd	3
									EXT	C1	hh ll	4
									IX2	D1	ee ff	4
									IX1	E1	ff	3
									IX	F1		2
									SP1	9EE1	ff	4
									SP2	9ED1	ee ff	5
COM <i>opr</i> COMA COM X COM <i>opr,X</i> COM ,X COM <i>opr,SP</i>	Complement (One's Complement)	$M \leftarrow (\overline{M}) = \$FF - (M)$ $A \leftarrow (\overline{A}) = \$FF - (M)$ $X \leftarrow (\overline{X}) = \$FF - (M)$ $M \leftarrow (\overline{M}) = \$FF - (M)$ $M \leftarrow (\overline{M}) = \$FF - (M)$ $M \leftarrow (\overline{M}) = \$FF - (M)$							DIR	33	dd	4
									INH	43		1
									INH	53		1
									IX1	63	ff	4
									IX	73		3
									SP1	9E63	ff	5
CPHX # <i>opr</i> CPHX <i>opr</i>	Compare H:X with M	$(H:X) - (M:M + 1)$							IMM	65	ii ii+1	3
									DIR	75	dd	4

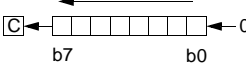
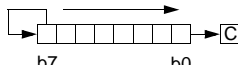
Table 7-1. Instruction Set Summary (Sheet 4 of 7)

Source Form	Operation	Description	Effect on CCR					Address Mode	Opcode	Operand	Cycles	
			V	H	I	N	Z					C
CPX #opr CPX opr CPX opr CPX ,X CPX opr,X CPX opr,X CPX opr,SP CPX opr,SP	Compare X with M	(X) - (M)	†	-	-	†	†	†	IMM DIR EXT IX2 IX1 IX SP1 SP2	A3 B3 C3 D3 E3 F3 9EE3 9ED3	ii dd hh ll ee ff ff ff ff ee ff	2 3 4 4 3 2 4 5
DAA	Decimal Adjust A	(A) ₁₀	U	-	-	†	†	†	INH	72		2
DBNZ opr,rel DBNZA rel DBNZX rel DBNZ opr,X,rel DBNZ X,rel DBNZ opr,SP,rel	Decrement and Branch if Not Zero	A ← (A) - 1 or M ← (M) - 1 or X ← (X) - 1 PC ← (PC) + 3 + rel ? (result) ≠ 0 PC ← (PC) + 2 + rel ? (result) ≠ 0 PC ← (PC) + 2 + rel ? (result) ≠ 0 PC ← (PC) + 3 + rel ? (result) ≠ 0 PC ← (PC) + 2 + rel ? (result) ≠ 0 PC ← (PC) + 4 + rel ? (result) ≠ 0							DIR INH INH IX1 IX SP1	3B 4B 5B 6B 7B 9E6B	dd rr rr rr ff rr rr ff rr	5 3 3 5 4 6
DEC opr DECA DECX DEC opr,X DEC ,X DEC opr,SP	Decrement	M ← (M) - 1 A ← (A) - 1 X ← (X) - 1 M ← (M) - 1 M ← (M) - 1 M ← (M) - 1	†	-	-	†	†	-	DIR INH INH IX1 IX SP1	3A 4A 5A 6A 7A 9E6A	dd ff ff ff	4 1 1 4 3 5
DIV	Divide	A ← (H:A)/(X) H ← Remainder	-	-	-	-	†	†	INH	52		7
EOR #opr EOR opr EOR opr EOR opr,X EOR opr,X EOR ,X EOR opr,SP EOR opr,SP	Exclusive OR M with A	A ← (A ⊕ M)	0	-	-	†	†	-	IMM DIR EXT IX2 IX1 IX SP1 SP2	A8 B8 C8 D8 E8 F8 9EE8 9ED8	ii dd hh ll ee ff ff ff ff ee ff	2 3 4 4 3 2 4 5
INC opr INCA INCX INC opr,X INC ,X INC opr,SP	Increment	M ← (M) + 1 A ← (A) + 1 X ← (X) + 1 M ← (M) + 1 M ← (M) + 1 M ← (M) + 1	†	-	-	†	†	-	DIR INH INH IX1 IX SP1	3C 4C 5C 6C 7C 9E6C	dd ff ff ff	4 1 1 4 3 5
JMP opr JMP opr JMP opr,X JMP opr,X JMP ,X	Jump	PC ← Jump Address	-	-	-	-	-	-	DIR EXT IX2 IX1 IX	BC CC DC EC FC	dd hh ll ee ff ff	2 3 4 3 2
JSR opr JSR opr JSR opr,X JSR opr,X JSR ,X	Jump to Subroutine	PC ← (PC) + n (n = 1, 2, or 3) Push (PCL); SP ← (SP) - 1 Push (PCH); SP ← (SP) - 1 PC ← Unconditional Address	-	-	-	-	-	-	DIR EXT IX2 IX1 IX	BD CD DD ED FD	dd hh ll ee ff ff	4 5 6 5 4
LDA #opr LDA opr LDA opr LDA opr,X LDA opr,X LDA ,X LDA opr,SP LDA opr,SP	Load A from M	A ← (M)	0	-	-	†	†	-	IMM DIR EXT IX2 IX1 IX SP1 SP2	A6 B6 C6 D6 E6 F6 9EE6 9ED6	ii dd hh ll ee ff ff ff ff ee ff	2 3 4 4 3 2 4 5

Table 7-1. Instruction Set Summary (Sheet 5 of 7)

Source Form	Operation	Description	Effect on CCR						Address Mode	Opcode	Operand	Cycles
			V	H	I	N	Z	C				
LDHX #opr LDHX opr	Load H:X from M	$H:X \leftarrow (M:M + 1)$	0	-	-	t	t	-	IMM DIR	45 55	ii jj dd	3 4
LDX #opr LDX opr LDX opr LDX opr,X LDX opr,X LDX ,X LDX opr,SP LDX opr,SP	Load X from M	$X \leftarrow (M)$	0	-	-	t	t	-	IMM DIR EXT IX2 IX1 IX SP1 SP2	AE BE CE DE EE FE 9EEE 9EDE	ii dd hh ll ee ff ff ff ff ee ff	2 3 4 4 3 2 4 5
LSL opr LSLA LSLX LSL opr,X LSL ,X LSL opr,SP	Logical Shift Left (Same as ASL)		t	-	-	t	t	t	DIR INH INH IX1 IX SP1	38 48 58 68 78 9E68	dd ff ff	4 1 1 4 3 5
LSR opr LSRA LSRX LSR opr,X LSR ,X LSR opr,SP	Logical Shift Right		t	-	-	0	t	t	DIR INH INH IX1 IX SP1	34 44 54 64 74 9E64	dd ff ff	4 1 1 4 3 5
MOV opr,opr MOV opr,X+ MOV #opr,opr MOV X+,opr	Move	$(M)_{\text{Destination}} \leftarrow (M)_{\text{Source}}$ $H:X \leftarrow (H:X) + 1$ (IX+D, DIX+)	0	-	-	t	t	-	DD DIX+ IMD IX+D	4E 5E 6E 7E	dd dd dd ii dd dd	5 4 4 4
MUL	Unsigned multiply	$X:A \leftarrow (X) \times (A)$	-	0	-	-	-	0	INH	42		5
NEG opr NEGA NEGX NEG opr,X NEG ,X NEG opr,SP	Negate (Two's Complement)	$M \leftarrow -(M) = \$00 - (M)$ $A \leftarrow -(A) = \$00 - (A)$ $X \leftarrow -(X) = \$00 - (X)$ $M \leftarrow -(M) = \$00 - (M)$ $M \leftarrow -(M) = \$00 - (M)$	t	-	-	t	t	t	DIR INH INH IX1 IX SP1	30 40 50 60 70 9E60	dd ff ff	4 1 1 4 3 5
NOP	No Operation	None	-	-	-	-	-	-	INH	9D		1
NSA	Nibble Swap A	$A \leftarrow (A[3:0]:A[7:4])$	-	-	-	-	-	-	INH	62		3
ORA #opr ORA opr ORA opr ORA opr,X ORA opr,X ORA ,X ORA opr,SP ORA opr,SP	Inclusive OR A and M	$A \leftarrow (A) (M)$	0	-	-	t	t	-	IMM DIR EXT IX2 IX1 IX SP1 SP2	AA BA CA DA EA FA 9EEA 9EDA	ii dd hh ll ee ff ff ff ff ee ff	2 3 4 4 4 3 2 4 5
PSHA	Push A onto Stack	Push (A); $SP \leftarrow (SP) - 1$	-	-	-	-	-	-	INH	87		2
PSHH	Push H onto Stack	Push (H); $SP \leftarrow (SP) - 1$	-	-	-	-	-	-	INH	8B		2
PSHX	Push X onto Stack	Push (X); $SP \leftarrow (SP) - 1$	-	-	-	-	-	-	INH	89		2
PULA	Pull A from Stack	$SP \leftarrow (SP + 1)$; Pull (A)	-	-	-	-	-	-	INH	86		2
PULH	Pull H from Stack	$SP \leftarrow (SP + 1)$; Pull (H)	-	-	-	-	-	-	INH	8A		2
PULX	Pull X from Stack	$SP \leftarrow (SP + 1)$; Pull (X)	-	-	-	-	-	-	INH	88		2

Table 7-1. Instruction Set Summary (Sheet 6 of 7)

Source Form	Operation	Description	Effect on CCR						Address Mode	Opcode	Operand	Cycles
			V	H	I	N	Z	C				
ROL <i>opr</i> ROLA ROLX ROL <i>opr,X</i> ROL ,X ROL <i>opr,SP</i>	Rotate Left through Carry		†	-	-	†	†	†	DIR INH INH IX1 IX SP1	39 49 59 69 79 9E69	dd ff ff	4 1 1 4 3 5
ROR <i>opr</i> RORA RORX ROR <i>opr,X</i> ROR ,X ROR <i>opr,SP</i>	Rotate Right through Carry		†	-	-	†	†	†	DIR INH INH IX1 IX SP1	36 46 56 66 76 9E66	dd ff ff	4 1 1 4 3 5
RSP	Reset Stack Pointer	SP ← \$FF	-	-	-	-	-	-	INH	9C		1
RTI	Return from Interrupt	SP ← (SP) + 1; Pull (CCR) SP ← (SP) + 1; Pull (A) SP ← (SP) + 1; Pull (X) SP ← (SP) + 1; Pull (PCH) SP ← (SP) + 1; Pull (PCL)	†	†	†	†	†	†	INH	80		7
RTS	Return from Subroutine	SP ← SP + 1; Pull (PCH) SP ← SP + 1; Pull (PCL)	-	-	-	-	-	-	INH	81		4
SBC # <i>opr</i> SBC <i>opr</i> SBC <i>opr</i> SBC <i>opr,X</i> SBC <i>opr,X</i> SBC ,X SBC <i>opr,SP</i> SBC <i>opr,SP</i>	Subtract with Carry	A ← (A) - (M) - (C)	†	-	-	†	†	†	IMM DIR EXT IX2 IX1 IX SP1 SP2	A2 B2 C2 D2 E2 F2 9EE2 9ED2	ii dd hh ll ee ff ff ff ff ee ff	2 3 4 4 3 2 4 5
SEC	Set Carry Bit	C ← 1	-	-	-	-	-	1	INH	99		1
SEI	Set Interrupt Mask	I ← 1	-	-	1	-	-	-	INH	9B		2
STA <i>opr</i> STA <i>opr</i> STA <i>opr,X</i> STA <i>opr,X</i> STA ,X STA <i>opr,SP</i> STA <i>opr,SP</i>	Store A in M	M ← (A)	0	-	-	†	†	-	DIR EXT IX2 IX1 IX SP1 SP2	B7 C7 D7 E7 F7 9EE7 9ED7	dd hh ll ee ff ff ff ff ee ff	3 4 4 3 2 4 5
STHX <i>opr</i>	Store H:X in M	(M:M + 1) ← (H:X)	0	-	-	†	†	-	DIR	35	dd	4
STOP	Enable $\overline{\text{IRQ}}$ Pin; Stop Oscillator	I ← 0; Stop Oscillator	-	-	0	-	-	-	INH	8E		1
STX <i>opr</i> STX <i>opr</i> STX <i>opr,X</i> STX <i>opr,X</i> STX ,X STX <i>opr,SP</i> STX <i>opr,SP</i>	Store X in M	M ← (X)	0	-	-	†	†	-	DIR EXT IX2 IX1 IX SP1 SP2	BF CF DF EF FF 9EEF 9EDF	dd hh ll ee ff ff ff ff ee ff	3 4 4 3 2 4 5
SUB # <i>opr</i> SUB <i>opr</i> SUB <i>opr</i> SUB <i>opr,X</i> SUB <i>opr,X</i> SUB ,X SUB <i>opr,SP</i> SUB <i>opr,SP</i>	Subtract	A ← (A) - (M)	†	-	-	†	†	†	IMM DIR EXT IX2 IX1 IX SP1 SP2	A0 B0 C0 D0 E0 F0 9EE0 9ED0	ii dd hh ll ee ff ff ff ff ee ff	2 3 4 4 3 2 4 5

Table 7-1. Instruction Set Summary (Sheet 7 of 7)

Source Form	Operation	Description	Effect on CCR						Address Mode	Opcode	Operand	Cycles
			V	H	I	N	Z	C				
SWI	Software Interrupt	PC ← (PC) + 1; Push (PCL) SP ← (SP) - 1; Push (PCH) SP ← (SP) - 1; Push (X) SP ← (SP) - 1; Push (A) SP ← (SP) - 1; Push (CCR) SP ← (SP) - 1; I ← 1 PCH ← Interrupt Vector High Byte PCL ← Interrupt Vector Low Byte	-	-	1	-	-	-	INH	83		9
TAP	Transfer A to CCR	CCR ← (A)	†	†	†	†	†	†	INH	84		2
TAX	Transfer A to X	X ← (A)	-	-	-	-	-	-	INH	97		1
TPA	Transfer CCR to A	A ← (CCR)	-	-	-	-	-	-	INH	85		1
TST <i>opr</i> TSTA TSTX TST <i>opr,X</i> TST <i>,X</i> TST <i>opr,SP</i>	Test for Negative or Zero	(A) - \$00 or (X) - \$00 or (M) - \$00	0	-	-	†	†	-	DIR INH INH IX1 IX SP1	3D 4D 5D 6D 7D 9E6D	dd ff ff	3 1 1 3 2 4
TSX	Transfer SP to H:X	H:X ← (SP) + 1	-	-	-	-	-	-	INH	95		2
TXA	Transfer X to A	A ← (X)	-	-	-	-	-	-	INH	9F		1
TXS	Transfer H:X to SP	(SP) ← (H:X) - 1	-	-	-	-	-	-	INH	94		2

- | | | | |
|-------|---|------------|---|
| A | Accumulator | <i>n</i> | Any bit |
| C | Carry/borrow bit | <i>opr</i> | Operand (one or two bytes) |
| CCR | Condition code register | PC | Program counter |
| dd | Direct address of operand | PCH | Program counter high byte |
| dd rr | Direct address of operand and relative offset of branch instruction | PCL | Program counter low byte |
| DD | Direct to direct addressing mode | REL | Relative addressing mode |
| DIR | Direct addressing mode | <i>rel</i> | Relative program counter offset byte |
| DIX+ | Direct to indexed with post increment addressing mode | rr | Relative program counter offset byte |
| ee ff | High and low bytes of offset in indexed, 16-bit offset addressing | SP1 | Stack pointer, 8-bit offset addressing mode |
| EXT | Extended addressing mode | SP2 | Stack pointer 16-bit offset addressing mode |
| ff | Offset byte in indexed, 8-bit offset addressing | SP | Stack pointer |
| H | Half-carry bit | U | Undefined |
| H | Index register high byte | V | Overflow bit |
| hh ll | High and low bytes of operand address in extended addressing | X | Index register low byte |
| I | Interrupt mask | Z | Zero bit |
| ii | Immediate operand byte | & | Logical AND |
| IMD | Immediate source to direct destination addressing mode | | Logical OR |
| IMM | Immediate addressing mode | ⊕ | Logical EXCLUSIVE OR |
| INH | Inherent addressing mode | () | Contents of |
| IX | Indexed, no offset addressing mode | -() | Negation (two's complement) |
| IX+ | Indexed, no offset, post increment addressing mode | # | Immediate value |
| IX+D | Indexed with post increment to direct addressing mode | « | Sign extend |
| IX1 | Indexed, 8-bit offset addressing mode | ← | Loaded with |
| IX1+ | Indexed, 8-bit offset, post increment addressing mode | ? | If |
| IX2 | Indexed, 16-bit offset addressing mode | : | Concatenated with |
| M | Memory location | ‡ | Set or cleared |
| N | Negative bit | — | Not affected |

7.8 Opcode Map

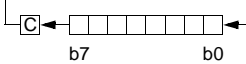
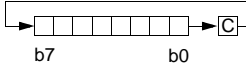
See Table 7-2.

Central Processor Unit (CPU)

Table 7-2. Opcode Map

MSB LSB		Bit Manipulation			Branch			Read-Modify-Write			Control			Register/Memory							
		DIR	DIR	REL	DIR	DIR	REL	INH	INH	IX1	SP1	IX	INH	INH	IMM	DIR	EXT	IX2	SP2	IX1	SP1
0	5	4	3	2	3	4	1	5	6	9E6	7	8	9	A	B	C	D	9ED	E	9EE	F
BRSET0 DIR 2	BSET0 DIR 2	BRA REL 2	NEG DIR 2	NEG REL 2	NEG IX1 1	NEG INH 1	NEG INH 1	NEG INH 1	NEG IX1 1	NEG SP1 3	NEG IX 1	RTI INH 1	BGE REL 3	SUB IMM 2	SUB DIR 2	SUB EXT 3	SUB IX2 4	SUB SP2 4	SUB IX1 3	SUB SP1 3	SUB IX 2
BCLR0 DIR 2	BCLR0 DIR 2	BRN REL 2	CBEQ DIR 3	CBEQ REL 3	CBEQ IX1+ 3	CBEQ INH 3	CBEQ INH 3	CBEQ IX1+ 3	CBEQ SP1 4	CBEQ SP1 4	CBEQ IX 4	RTS INH 1	BLT REL 2	CMP IMM 2	CMP DIR 3	CMP EXT 3	CMP IX2 4	CMP SP2 4	CMP IX1 3	CMP SP1 3	CMP IX 2
BSET1 DIR 2	BSET1 DIR 2	BHI REL 2	MUL DIR 3	MUL REL 3	NSA INH 1	DIV INH 1	DIV INH 1	NSA INH 1	DAA SP1 5	DAA SP1 5	DAA IX 1	BGT INH 2	BGT REL 2	SBC IMM 2	SBC DIR 3	SBC EXT 3	SBC IX2 4	SBC SP2 4	SBC IX1 3	SBC SP1 3	SBC IX 2
BCLR1 DIR 2	BCLR1 DIR 2	BLS REL 2	COMA DIR 2	COMA REL 2	COM IX1 4	COMX INH 1	COMX INH 1	COM IX1 4	COM SP1 5	COM SP1 5	COM IX 3	SWI INH 1	BLE REL 3	CPX IMM 2	CPX DIR 3	CPX EXT 3	CPX IX2 4	CPX SP2 4	CPX IX1 3	CPX SP1 3	CPX IX 2
BSET2 DIR 2	BSET2 DIR 2	BCC REL 2	LSRA DIR 2	LSRA REL 2	LSR INH 1	LSRX INH 1	LSRX INH 1	LSR INH 1	LSR SP1 5	LSR SP1 5	LSR IX 3	TAP INH 1	TXS REL 2	AND IMM 2	AND DIR 3	AND EXT 3	AND IX2 4	AND SP2 4	AND IX1 3	AND SP1 3	AND IX 2
BCLR2 DIR 2	BCLR2 DIR 2	BCS REL 2	LDHX DIR 3	LDHX REL 3	CPHX INH 3	LDHX INH 2	LDHX INH 2	CPHX INH 3	CPHX SP1 5	CPHX SP1 5	CPHX IX 4	TPA INH 1	TSX REL 2	BIT IMM 2	BIT DIR 3	BIT EXT 3	BIT IX2 4	BIT SP2 4	BIT IX1 3	BIT SP1 3	BIT IX 2
BSET3 DIR 2	BSET3 DIR 2	BNE REL 2	RORA DIR 2	RORA REL 2	ROR INH 1	RORX INH 1	RORX INH 1	ROR INH 1	ROR SP1 5	ROR SP1 5	ROR IX 3	PULA INH 1	PULA REL 2	LDA IMM 2	LDA DIR 3	LDA EXT 3	LDA IX2 4	LDA SP2 4	LDA IX1 3	LDA SP1 3	LDA IX 2
BCLR3 DIR 2	BCLR3 DIR 2	BEQ REL 2	ASRA DIR 2	ASRA REL 2	ASR INH 1	ASRX INH 1	ASRX INH 1	ASR INH 1	ASR SP1 5	ASR SP1 5	ASR IX 3	PSHA INH 1	TAX REL 1	AIS IMM 2	STA DIR 3	STA EXT 3	STA IX2 4	STA SP2 4	STA IX1 3	STA SP1 3	STA IX 2
BSET4 DIR 2	BSET4 DIR 2	BHCC REL 2	LSLA DIR 2	LSLA REL 2	LSL INH 1	LSLX INH 1	LSLX INH 1	LSL INH 1	LSL SP1 5	LSL SP1 5	LSL IX 3	PULX INH 1	CLC REL 1	EOR IMM 2	EOR DIR 3	EOR EXT 3	EOR IX2 4	EOR SP2 4	EOR IX1 3	EOR SP1 3	EOR IX 2
BCLR4 DIR 2	BCLR4 DIR 2	BHCS REL 2	ROLA DIR 2	ROLA REL 2	ROL INH 1	ROXX INH 1	ROXX INH 1	ROL INH 1	ROL SP1 5	ROL SP1 5	ROL IX 3	PSHX INH 1	SEC REL 1	ADC IMM 2	ADC DIR 3	ADC EXT 3	ADC IX2 4	ADC SP2 4	ADC IX1 3	ADC SP1 3	ADC IX 2
BSET5 DIR 2	BSET5 DIR 2	BPL REL 2	DECA DIR 2	DECA REL 2	DEC INH 1	DECA INH 1	DECA INH 1	DEC INH 1	DEC SP1 5	DEC SP1 5	DEC IX 3	PULH INH 1	CLI REL 2	ORA IMM 2	ORA DIR 3	ORA EXT 3	ORA IX2 4	ORA SP2 4	ORA IX1 3	ORA SP1 3	ORA IX 2
BCLR5 DIR 2	BCLR5 DIR 2	BMI REL 2	DBNZ DIR 2	DBNZ REL 2	DBNZ INH 3	DBNZX INH 2	DBNZX INH 2	DBNZ INH 3	DBNZ SP1 6	DBNZ SP1 6	DBNZ IX 4	PSHH INH 2	SEI REL 2	ADD IMM 2	ADD DIR 3	ADD EXT 3	ADD IX2 4	ADD SP2 4	ADD IX1 3	ADD SP1 3	ADD IX 2
BSET6 DIR 2	BSET6 DIR 2	BMC REL 2	INCA DIR 2	INCA REL 2	INC INH 1	INCX INH 1	INCX INH 1	INC INH 1	INC SP1 5	INC SP1 5	INC IX 3	CLRH INH 1	RSP REL 1	JMP IMM 2	JMP DIR 3	JMP EXT 3	JMP IX2 4	JMP SP2 4	JMP IX1 3	JMP SP1 3	JMP IX 2
BCLR6 DIR 2	BCLR6 DIR 2	BMS REL 2	TSTA DIR 2	TSTA REL 2	TST INH 1	TSTX INH 1	TSTX INH 1	TST INH 1	TST SP1 5	TST SP1 5	TST IX 3	NOP INH 1	BRSR REL 4	JSR IMM 2	JSR DIR 3	JSR EXT 3	JSR IX2 4	JSR SP2 4	JSR IX1 3	JSR SP1 3	JSR IX 2
BSET7 DIR 2	BSET7 DIR 2	BIL REL 2	MOV DIR 3	MOV REL 3	MOV INH 4	MOV INH 4	MOV INH 4	MOV INH 4	MOV SP1 4	MOV SP1 4	MOV IX 4	STOP INH 1	* REL 2	LDX IMM 2	LDX DIR 3	LDX EXT 3	LDX IX2 4	LDX SP2 4	LDX IX1 3	LDX SP1 3	LDX IX 2
BCLR7 DIR 2	BCLR7 DIR 2	BIH REL 2	CLRA DIR 2	CLRA REL 2	CLR INH 1	CLR INH 1	CLR INH 1	CLR INH 1	CLR SP1 4	CLR SP1 4	CLR IX 3	WAIT INH 1	TXA REL 1	AIX IMM 2	STX DIR 3	STX EXT 3	STX IX2 4	STX SP2 4	STX IX1 3	STX SP1 3	STX IX 2

MSB	0
LSB	0

High Byte of Opcode in Hexadecimal

MSB	0
LSB	0

Low Byte of Opcode in Hexadecimal

Cycles
Number of Bytes / Addressing Mode

SP1 Stack Pointer, 8-Bit Offset
SP2 Stack Pointer, 16-Bit Offset
IX+ Indexed, No Offset with Post Increment
IX1+ Indexed, 1-Byte Offset with Post Increment
IX+D Indexed-Direct
IX+D Indexed-Direct

*Pre-byte for stack pointer indexed instructions

Section 8. External Interrupt (IRQ)

8.1 Introduction

This section describes the external interrupt (IRQ) module, which supports external interrupt functions.

8.2 Features

Features of the IRQ module include:

- A dedicated external interrupt pin, $\overline{\text{IRQ}}$
- Hysteresis buffers

8.3 Functional Description

A logic 0 applied to any of the external interrupt pins can latch a CPU interrupt request. Figure 8-1 shows the structure of the IRQ module.

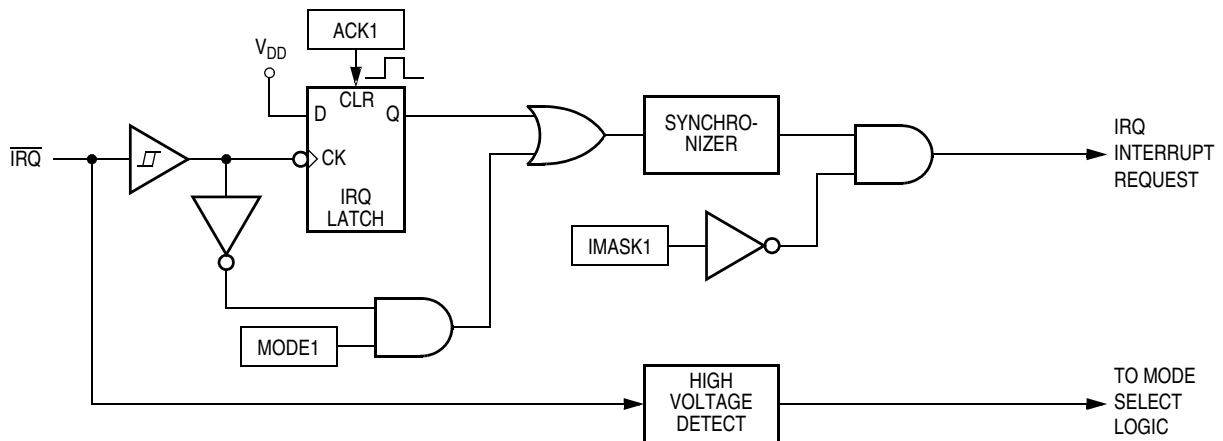

Figure 8-1. IRQ Module Block Diagram

Addr.	Register Name	Bit 7	6	5	4	3	2	1	Bit 0	
\$003F	IRQ Status/Control Register (ISCR) See page 105.	Read:	0	0	0	0	IRQF	0	IMASK1	MODE1
		Write:	R	R	R	R		ACK1		
		Reset:	0	0	0	0	0	0	0	0

R = Reserved

Figure 8-2. IRQ I/O Register Summary

Interrupt signals on the $\overline{\text{IRQ}}$ pin are latched into the IRQ1 latch. An interrupt latch remains set until one of the following actions occurs:

- Vector fetch — A vector fetch automatically generates an interrupt acknowledge signal that clears the latch that caused the vector fetch.
- Software clear — Software can clear an interrupt latch by writing to the appropriate acknowledge bit in the interrupt status and control register (ISCR). Writing a logic 1 to the ACK1 bit clears the IRQ1 latch.
- Reset — A reset automatically clears both interrupt latches.

The external interrupt pins are falling-edge-triggered and are software-configurable to be both falling-edge and low-level-triggered. The MODE1 bit in the ISCR controls the triggering sensitivity of the $\overline{\text{IRQ}}$ pin.

When the interrupt pin is edge-triggered only, the interrupt latch remains set until a vector fetch, software clear, or reset occurs.

When the interrupt pin is both falling-edge and low-level-triggered, the interrupt latch remains set until both of these occur:

- Vector fetch, software clear, or reset
- Return of the interrupt pin to logic 1

The vector fetch or software clear can occur before or after the interrupt pin returns to logic 1. As long as the pin is low, the interrupt request remains pending.

When set, the IMASK1 bit in the ISCR masks all external interrupt requests. A latched interrupt request is not presented to the interrupt priority logic unless the IMASK bit is clear.

NOTE: *The interrupt mask (I) in the condition code register (CCR) masks all interrupt requests, including external interrupt requests. (See [Figure 8-3](#).)*

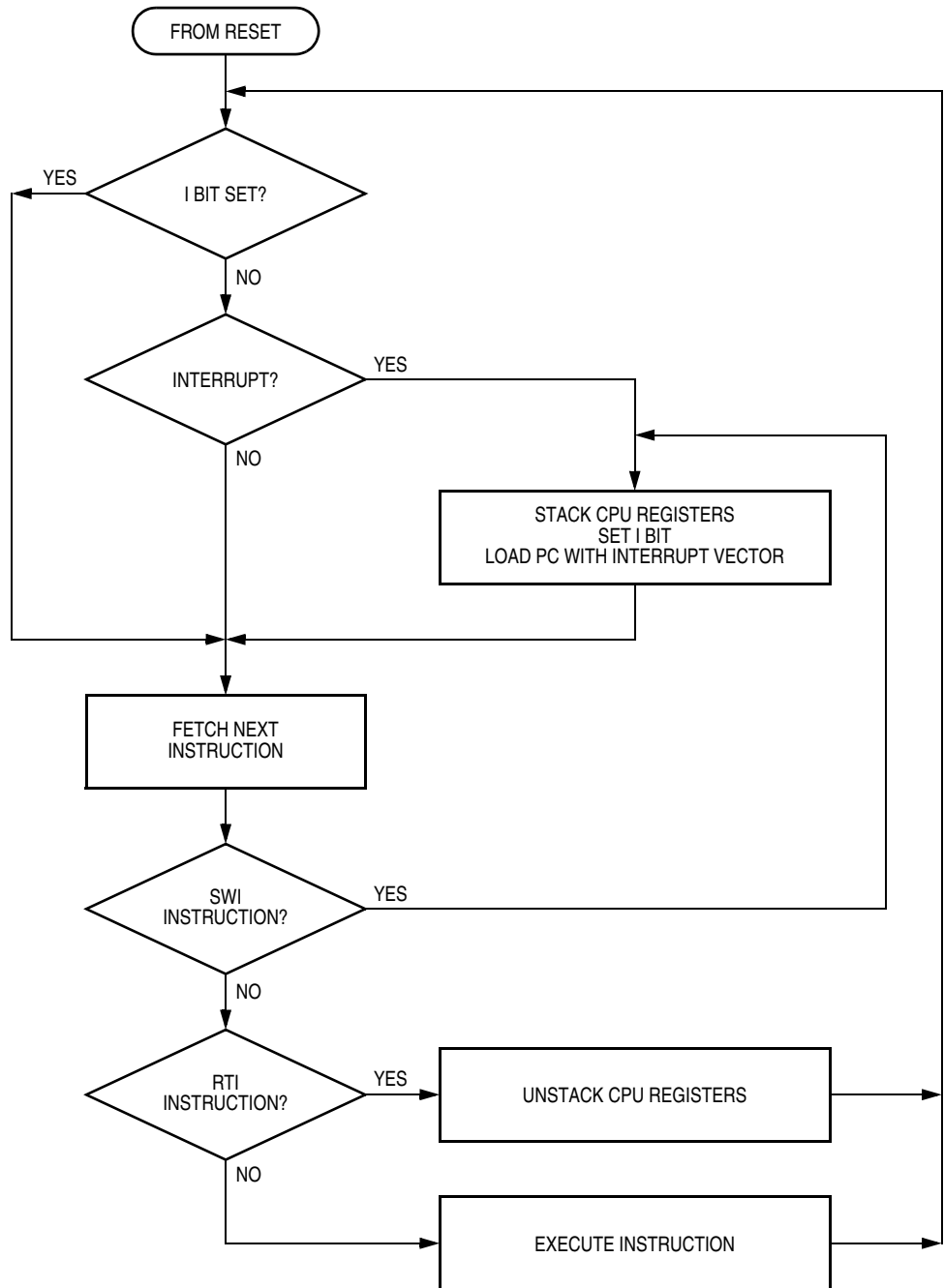

Figure 8-3. IRQ Interrupt Flowchart

8.4 $\overline{\text{IRQ}}$ Pin

A logic 0 on the $\overline{\text{IRQ}}$ pin can latch an interrupt request into the IRQ latch. A vector fetch, software clear, or reset clears the IRQ latch.

If the MODE1 bit is set, the $\overline{\text{IRQ}}$ pin is both falling-edge-sensitive and low-level-sensitive. With MODE1 set, both of these actions must occur to clear the IRQ1 latch:

- Vector fetch, software clear, or reset — A vector fetch generates an interrupt acknowledge signal to clear the latch. Software can generate the interrupt acknowledge signal by writing a logic 1 to the ACK1 bit in the interrupt status and control register (ISCR). The ACK1 bit is useful in applications that poll the $\overline{\text{IRQ}}$ pin and require software to clear the IRQ1 latch. Writing to the ACK1 bit can also prevent spurious interrupts due to noise. Setting ACK1 does not affect subsequent transitions on the $\overline{\text{IRQ}}$ pin. A falling edge that occurs after writing to the ACK1 bit latches another interrupt request. If the IRQ1 mask bit, IMASK1, is clear, the CPU loads the program counter with the vector address at locations \$FFFA and \$FFFB.
- Return of the $\overline{\text{IRQ}}$ pin to logic 1 — As long as the $\overline{\text{IRQ}}$ pin is at logic 0, the IRQ1 latch remains set.

8.5 $\overline{\text{IRQ}}$ Pin

A logic 0 on the $\overline{\text{IRQ}}$ pin can latch an interrupt request into the IRQ latch. A vector fetch, software clear, or reset clears the IRQ latch.

If the MODE1 bit is set, the $\overline{\text{IRQ}}$ pin is both falling-edge-sensitive and low-level-sensitive. With MODE1 set, both of these actions must occur to clear the IRQ1 latch:

- Vector fetch, software clear, or reset — A vector fetch generates an interrupt acknowledge signal to clear the latch. Software can generate the interrupt acknowledge signal by writing a logic 1 to the ACK1 bit in the interrupt status and control register (ISCR). The ACK1 bit is useful in applications that poll the $\overline{\text{IRQ}}$ pin and require software to clear the IRQ1 latch. Writing to the ACK1 bit can also prevent spurious interrupts due to noise. Setting ACK1 does not affect subsequent transitions on the $\overline{\text{IRQ}}$ pin. A falling edge that occurs after writing to the ACK1 bit latches another interrupt request. If the IRQ1 mask bit, IMASK1, is clear, the CPU loads the program counter with the vector address at locations \$FFFA and \$FFFB.
- Return of the $\overline{\text{IRQ}}$ pin to logic 1 — As long as the $\overline{\text{IRQ}}$ pin is at logic 0, the IRQ1 latch remains set.

The vector fetch or software clear and the return of the $\overline{\text{IRQ}}$ pin to logic 1 can occur in any order. The interrupt request remains pending as long as the $\overline{\text{IRQ}}$ pin is at logic 0.

If the MODE1 bit is clear, the $\overline{\text{IRQ}}$ pin is falling-edge-sensitive only. With MODE1 clear, a vector fetch or software clear immediately clears the IRQ1 latch.

Use the branch if $\overline{\text{IRQ}}$ pin high (BIH) or branch if $\overline{\text{IRQ}}$ pin low (BIL) instruction to read the logic level on the $\overline{\text{IRQ}}$ pin.

NOTE: When using the level-sensitive interrupt trigger, avoid false interrupts by masking interrupt requests in the interrupt routine.

8.6 IRQ Status and Control Register

The IRQ status and control register (ISCR) has these functions:

- Clears the IRQ interrupt latch
- Masks IRQ interrupt requests
- Controls triggering sensitivity of the $\overline{\text{IRQ}}$ interrupt pin

Address: \$003F

	Bit 7	6	5	4	3	2	1	Bit 0
Read:	0	0	0	0	IRQF	0	IMASK1	MODE1
Write:	R	R	R	R		ACK1		
Reset:	0	0	0	0	0	0	0	0

R = Reserved

Figure 8-4. IRQ Status and Control Register (ISCR)

ACK1 — IRQ Interrupt Request Acknowledge Bit

Writing a logic 1 to this write-only bit clears the IRQ latch. ACK1 always reads as logic 0. Reset clears ACK1.

IMASK1 — IRQ Interrupt Mask Bit

Writing a logic 1 to this read/write bit disables IRQ interrupt requests. Reset clears IMASK1.

1 = IRQ interrupt requests disabled

0 = IRQ interrupt requests enabled

MODE1 — IRQ Edge/Level Select Bit

This read/write bit controls the triggering sensitivity of the $\overline{\text{IRQ}}$ pin. Reset clears MODE1.

1 = $\overline{\text{IRQ}}$ interrupt requests on falling edges and low levels

0 = $\overline{\text{IRQ}}$ interrupt requests on falling edges only

IRQF — IRQ Flag

This read-only bit acts as a status flag, indicating an IRQ event occurred.

1 = External IRQ event occurred.

0 = External IRQ event did not occur.

Section 9. Low-Voltage Inhibit (LVI)

9.1 Introduction

This section describes the low-voltage inhibit (LVI) module, which monitors the voltage on the V_{DD} pin and can force a reset when the V_{DD} voltage falls to the LVI trip voltage.

9.2 Features

Features of the LVI module include:

- Programmable LVI reset
- Programmable power consumption
- Digital filtering of V_{DD} pin level
- Selectable LVI trip voltage

9.3 Functional Description

Figure 9-1 shows the structure of the LVI module. The LVI is enabled out of reset. The LVI module contains a bandgap reference circuit and comparator. The LVI power bit, LVIPWR, enables the LVI to monitor V_{DD} voltage. The LVI reset bit, LVIRST, enables the LVI module to generate a reset when V_{DD} falls below a voltage, V_{LVRX} , and remains at or below that level for nine or more consecutive CGMXCLK. V_{LVRX} and V_{LVHX} are determined by the TRPSEL bit in the LVISCR (see **Figure 9-2**). LVIPWR and LVIRST are in the configuration register (CONFIG). See **Section 5. Configuration Register (CONFIG)**.

Once an LVI reset occurs, the MCU remains in reset until V_{DD} rises above a voltage, $V_{LVRX} + V_{LVHX}$. V_{DD} must be above $V_{LVRX} + V_{LVHX}$ for only one CPU cycle to bring the MCU out of reset. See **14.3.2.6 Low-Voltage Inhibit (LVI) Reset**. The output of the comparator controls the state of the LVIOUT flag in the LVI status register (LVISCR).

An LVI reset also drives the \overline{RST} pin low to provide low-voltage protection to external peripheral devices. See **19.5 DC Electrical Characteristics**.

Low-Voltage Inhibit (LVI)

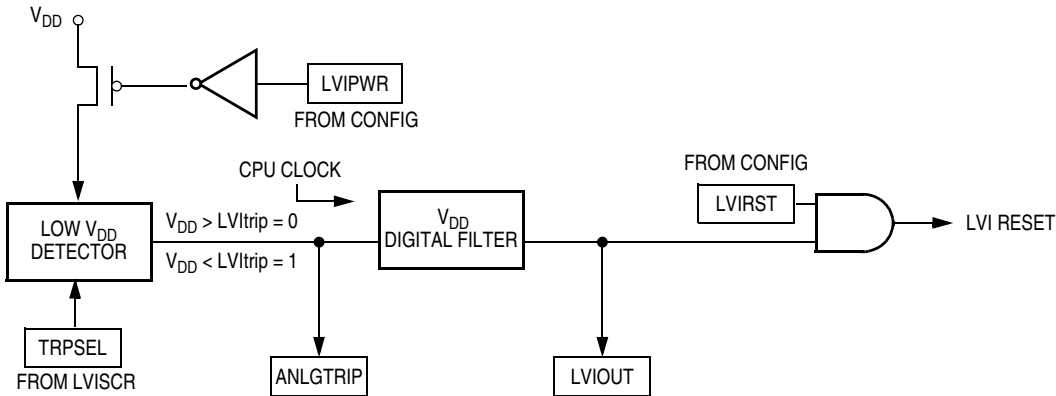

Figure 9-1. LVI Module Block Diagram

Addr.	Register Name	Bit 7	6	5	4	3	2	1	Bit 0	
\$FE0F	LVI Status and Control Register (LVISCR) See page 109.	Read:	LVIOUT	0	TRPSEL	0	0	0	0	
		Write:	R	R		R	R	R	R	R
		Reset:	0	0	0	0	0	0	0	0

R = Reserved

Figure 9-2. LVI I/O Register Summary

9.3.1 Polled LVI Operation

In applications that can operate at V_{DD} levels below V_{LVRX} , software can monitor V_{DD} by polling the LVIOUT bit. In the configuration register, the LVIPWR bit must be 1 to enable the LVI module, and the LVIRST bit must be 0 to disable LVI resets. See [Section 5. Configuration Register \(CONFIG\)](#). TRPSEL in the LVISCR selects V_{LVRX} .

9.3.2 Forced Reset Operation

In applications that require V_{DD} to remain above V_{LVRX} , enabling LVI resets allows the LVI module to reset the MCU when V_{DD} falls to the V_{LVRX} level and remains at or below that level for nine or more consecutive CPU cycles. In the CONFIG register, the LVIPWR and LVIRST bits must be 1s to enable the LVI module and to enable LVI resets. TRPSEL in the LVISCR selects V_{LVRX} .

9.3.3 False Reset Protection

The V_{DD} pin level is digitally filtered to reduce false resets due to power supply noise. In order for the LVI module to reset the MCU, V_{DD} must remain at or below V_{LVRX} for nine or more consecutive CPU cycles. V_{DD} must be above $V_{LVRX} + V_{LVHX}$ for only one CPU cycle to bring the MCU out of reset. TRPSEL in the LVISCR selects $V_{LVRX} + V_{LVHX}$.

9.3.4 LVI Trip Selection

The TRPSEL bit allows the user to chose between 5 percent and 10 percent tolerance when monitoring the supply voltage. The 10 percent option is enabled out of reset. Writing a 1 to TRPSEL will enable 5 percent option.

NOTE: *The microcontroller is guaranteed to operate at a minimum supply voltage. The trip point (VLVR1 or VLVR2) may be lower than this. See [19.5 DC Electrical Characteristics](#).*

9.4 LVI Status and Control Register

The LVI status register (LVISCR) flags V_{DD} voltages below the V_{LVRX} level.

Address: \$FE0F

	Bit 7	6	5	4	3	2	1	Bit 0
Read:	LVIOUT	0	TRPSEL	0	0	0	0	0
Write:	R	R		R	R	R	R	R
Reset:	0	0	0	0	0	0	0	0

R = Reserved

Figure 9-3. LVI Status and Control Register (LVISCR)

LVIOUT — LVI Output Bit

This read-only flag becomes set when the V_{DD} voltage falls below the V_{LVRX} voltage for 32 to 40 CGMXCLK cycles. See [Table 9-1](#). Reset clears the LVIOUT bit.

Table 9-1. LVIOUT Bit Indication

V_{DD}		LVIOUT
At Level:	For Number of CGMXCLK Cycles:	
$V_{DD} > V_{LVRX} + V_{LVHX}$	Any	0
$V_{DD} < V_{LVRX}$	< 32 CGMXCLK cycles	0
$V_{DD} < V_{LVRX}$	Between 32 & 40 CGMXCLK cycles	0 or 1
$V_{DD} < V_{LVRX}$	> 40 CGMXCLK cycles	1
$V_{LVRX} < V_{DD} < V_{LVRX} + V_{LVHX}$	Any	Previous value

TRPSEL — LVI Trip Select Bit

This bit selects the LVI trip point. Reset clears this bit.

1 = 5 percent tolerance. The trip point and recovery point are determined by V_{LVR1} and V_{LVH1} , respectively.

0 = 10 percent tolerance. The trip point and recovery point are determined by V_{LVR2} and V_{LVH2} , respectively.

NOTE: *If LVIRST and LVIPWR are 0s, note that when changing the tolerance, LVI reset will be generated if the supply voltage is below the trip point.*

9.5 LVI Interrupts

The LVI module does not generate interrupt requests.

9.6 Wait Mode

The WAIT instruction puts the MCU in low power-consumption standby mode.

With the LVIPWR bit in the configuration register programmed to 1, the LVI module is active after a WAIT instruction.

With the LVIRST bit in the configuration register programmed to 1, the LVI module can generate a reset and bring the MCU out of wait mode.

9.7 Stop Mode

If enabled, the LVI module remains active in stop mode. If enabled to generate resets, the LVI module can generate a reset and bring the MCU out of stop mode.

Section 10. Input/Output (I/O) Ports (PORTS)

10.1 Introduction

Thirty-seven bidirectional input-output (I/O) pins and seven input pins form six parallel ports. All I/O pins are programmable as inputs or outputs.

When using the 56-pin package version:

- Set the data direction register bits in DDRC such that bit 1 is written to a logic 1 (along with any other output bits on port C).
- Set the data direction register bits in DDRE such that bits 0, 1, and 2 are written to a logic 1 (along with any other output bits on port E).
- Set the data direction register bits in DDRF such that bits 0, 1, 2, and 3 are written to a logic 1 (along with any other output bits on port F).

NOTE: Connect any unused I/O pins to an appropriate logic level, either V_{DD} or V_{SS} . Although PWM6–PWM1 do not require termination for proper operation, termination reduces excess current consumption and the possibility of electrostatic damage.

Addr.	Register Name	Bit 7	6	5	4	3	2	1	Bit 0	
\$0000	Port A Data Register (PTA) See page 113.	Read:	PTA7	PTA6	PTA5	PTA4	PTA3	PTA2	PTA1	PTA0
		Write:								
		Reset:	Unaffected by reset							
\$0001	Port B Data Register (PTB) See page 115.	Read:	PTB7	PTB6	PTB5	PTB4	PTB3	PTB2	PTB1	PTB0
		Write:								
		Reset:	Unaffected by reset							
\$0002	Port C Data Register (PTC) See page 117.	Read:	0	PTC6	PTC5	PTC4	PTC3	PTC2	PTC1	PTC0
		Write:	R							
		Reset:	Unaffected by reset							
\$0003	Port D Data Register (PTD) See page 119.	Read:	0	PTD6	PTD5	PTD4	PTD3	PTD2	PTD1	PTD0
		Write:	R	R	R	R	R	R	R	R
		Reset:	Unaffected by reset							
			R	= Reserved						

Figure 10-1. I/O Port Register Summary

Input/Output (I/O) Ports (PORTS)

Addr.	Register Name	Bit 7	6	5	4	3	2	1	Bit 0	
\$0004	Data Direction Register A (DDRA) See page 113.	Read:	DDRA7	DDRA6	DDRA5	DDRA4	DDRA3	DDRA2	DDRA1	DDRA0
		Write:								
		Reset:	0	0	0	0	0	0	0	0
\$0005	Data Direction Register B (DDRB) See page 115.	Read:	DDRB7	DDRB6	DDRB5	DDRB4	DDRB3	DDRB2	DDRB1	DDRB0
		Write:								
		Reset:	0	0	0	0	0	0	0	0
\$0006	Data Direction Register C (DDRC) See page 117.	Read:	0	DDRC6	DDRC5	DDRC4	DDRC3	DDRC2	DDRC1	DDRC0
		Write:	R							
		Reset:	0	0	0	0	0	0	0	0
\$0007	Unimplemented	Unimplemented								
\$0008	Port E Data Register (PTE) See page 120.	Read:	PTE7	PTE6	PTE5	PTE4	PTE3	PTE2	PTE1	PTE0
		Write:								
		Reset:	Unaffected by reset							
\$0009	Port F Data Register (PTF) See page 122.	Read:	0	0	PTF5	PTF4	PTF3	PTF2	PTF1	PTF0
		Write:	R	R						
		Reset:	Unaffected by reset							
\$000A	Unimplemented	Unimplemented								
\$000B	Unimplemented	Unimplemented								
\$000C	Data Direction Register E (DDRE) See page 120.	Read:	DDRE7	DDRE6	DDRE5	DDRE4	DDRE3	DDRE2	DDRE1	DDRE0
		Write:								
		Reset:	0	0	0	0	0	0	0	0
\$000D	Data Direction Register F (DDRF) See page 122.	Read:	0	0	DDRF5	DDRF4	DDRF3	DDRF2	DDRF1	DDRF0
		Write:	R	R						
		Reset:			0	0	0	0	0	0

R = Reserved

Figure 10-1. I/O Port Register Summary (Continued)

Freescale Semiconductor, Inc.

10.2 Port A

Port A is an 8-bit, general-purpose, bidirectional I/O port.

10.2.1 Port A Data Register

The port A data register (PTA) contains a data latch for each of the eight port A pins.

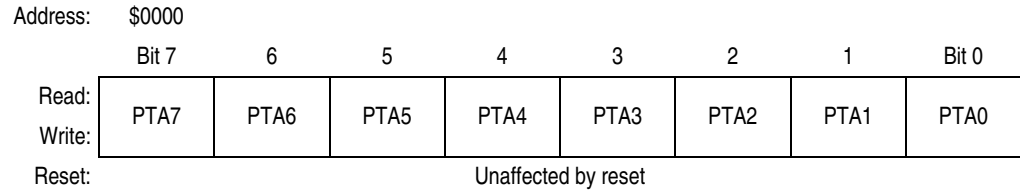

Figure 10-2. Port A Data Register (PTA)

PTA[7:0] — Port A Data Bits

These read/write bits are software programmable. Data direction of each port A pin is under the control of the corresponding bit in data direction register A. Reset has no effect on port A data.

10.2.2 Data Direction Register A

Data direction register A (DDRA) determines whether each port A pin is an input or an output. Writing a logic 1 to a DDRA bit enables the output buffer for the corresponding port A pin; a logic 0 disables the output buffer.

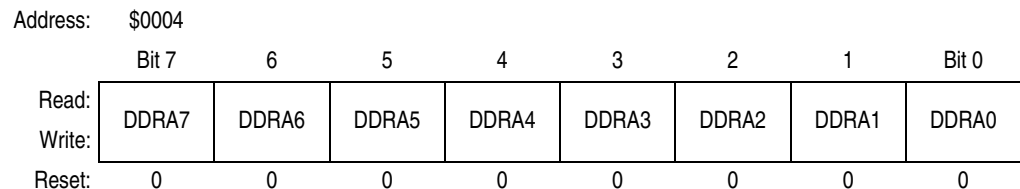

Figure 10-3. Data Direction Register A (DDRA)

DDRA[7:0] — Data Direction Register A Bits

These read/write bits control port A data direction. Reset clears DDRA[7:0], configuring all port A pins as inputs.

- 1 = Corresponding port A pin configured as output
- 0 = Corresponding port A pin configured as input

NOTE: Avoid glitches on port A pins by writing to the port A data register before changing data direction register A bits from 0 to 1.

Figure 10-4 shows the port A I/O logic.

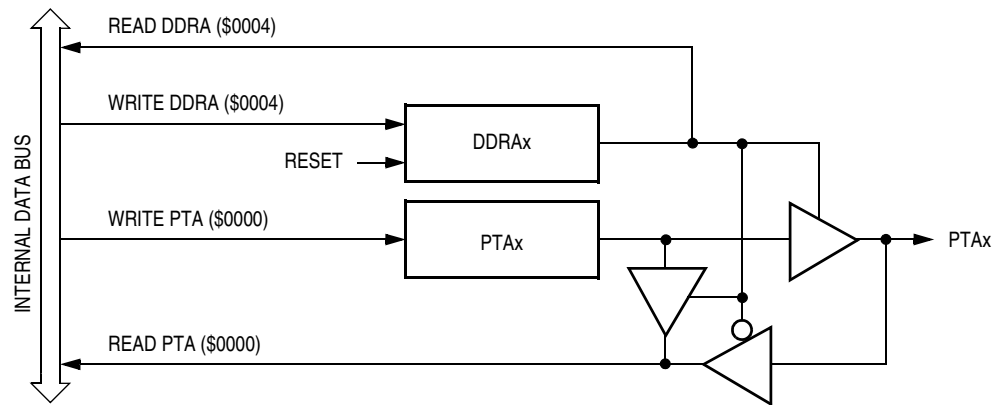

Figure 10-4. Port A I/O Circuit

When bit DDRAx is a logic 1, reading address \$0000 reads the PTAx data latch. When bit DDRAx is a logic 0, reading address \$0000 reads the voltage level on the pin. The data latch can always be written, regardless of the state of its data direction bit. Table 10-1 summarizes the operation of the port A pins.

Table 10-1. Port A Pin Functions

DDRA Bit	PTA Bit	I/O Pin Mode	Accesses to DDRA	Accesses to PTA	
			Read/Write	Read	Write
0	X ⁽¹⁾	Input, Hi-Z ⁽²⁾	DDRA[7:0]	Pin	PTA[7:0] ⁽³⁾
1	X	Output	DDRA[7:0]	PTA[7:0]	PTA[7:0]

1. X = don't care
2. Hi-Z = high impedance
3. Writing affects data register, but does not affect input.

10.3 Port B

Port B is an 8-bit, general-purpose, bidirectional I/O port that shares its pins with the analog-to-digital convertor (ADC) module.

10.3.1 Port B Data Register

The port B data register (PTB) contains a data latch for each of the eight port B pins.

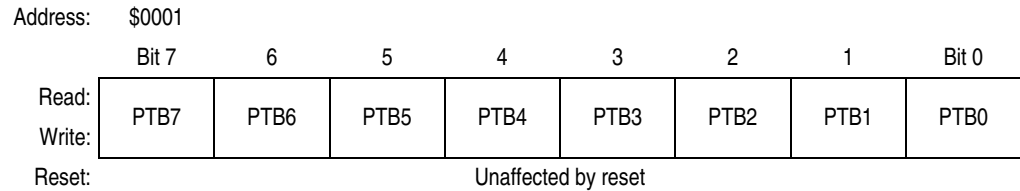

Figure 10-5. Port B Data Register (PTB)

PTB[7:0] — Port B Data Bits

These read/write bits are software-programmable. Data direction of each port B pin is under the control of the corresponding bit in data direction register B. Reset has no effect on port B data.

10.3.2 Data Direction Register B

Data direction register B (DDRB) determines whether each port B pin is an input or an output. Writing a logic 1 to a DDRB bit enables the output buffer for the corresponding port B pin; a logic 0 disables the output buffer.

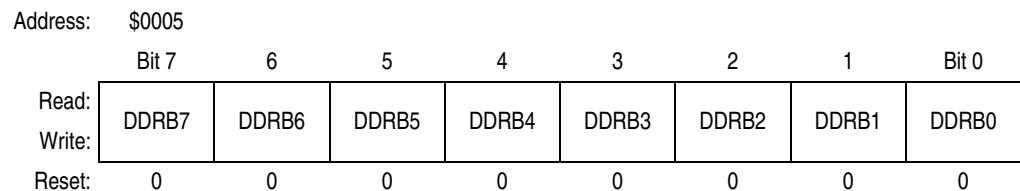

Figure 10-6. Data Direction Register B (DDRB)

DDRB[7:0] — Data Direction Register B Bits

These read/write bits control port B data direction. Reset clears DDRB[7:0], configuring all port B pins as inputs.

- 1 = Corresponding port B pin configured as output
- 0 = Corresponding port B pin configured as input

NOTE: *Avoid glitches on port B pins by writing to the port B data register before changing data direction register B bits from 0 to 1.*

Figure 10-7 shows the port B I/O logic.

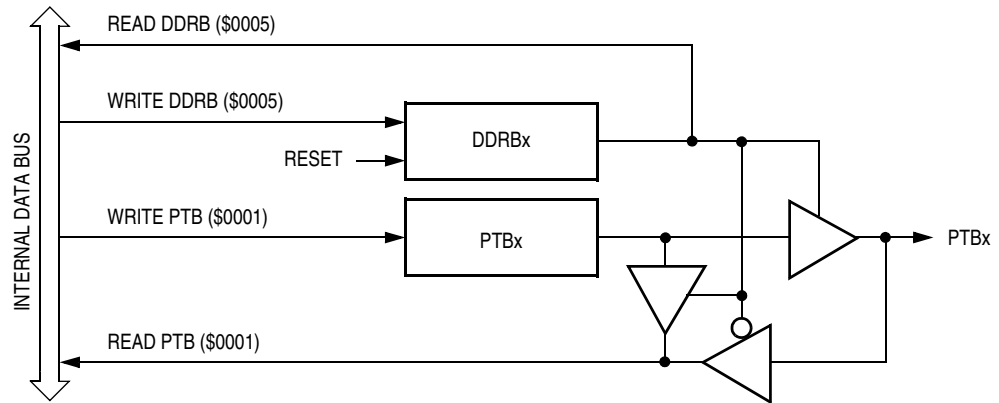

Figure 10-7. Port B I/O Circuit

When bit DDRBx is a logic 1, reading address \$0001 reads the PTBx data latch. When bit DDRBx is a logic 0, reading address \$0001 reads the voltage level on the pin. The data latch can always be written, regardless of the state of its data direction bit. Table 10-2 summarizes the operation of the port B pins.

Table 10-2. Port B Pin Functions

DDR B Bit	PTB Bit	I/O Pin Mode	Accesses to DDRB	Accesses to PTB	
			Read/Write	Read	Write
0	X ⁽¹⁾	Input, Hi-Z ⁽²⁾	DDR B[7:0]	Pin	PTB[7:0] ⁽³⁾
1	X	Output	DDR B[7:0]	PTB[7:0]	PTB[7:0]

1. X = don't care
2. Hi-Z = high impedance
3. Writing affects data register, but does not affect input.

10.4 Port C

Port C is a 7-bit, general-purpose, bidirectional I/O port that shares two of its pins with the analog-to-digital convertor module (ADC).

10.4.1 Port C Data Register

The port C data register (PTC) contains a data latch for each of the seven port C pins.

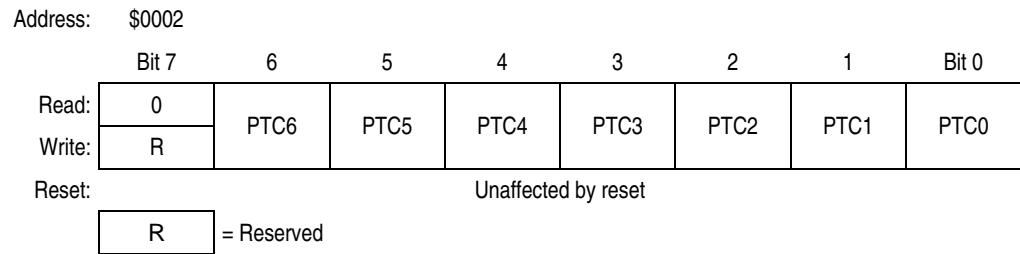

Figure 10-8. Port C Data Register (PTC)

PTC[6:0] — Port C Data Bits

These read/write bits are software-programmable. Data direction of each port C pin is under the control of the corresponding bit in data direction register C. Reset has no effect on port C data.

10.4.2 Data Direction Register C

Data direction register C (DDRC) determines whether each port C pin is an input or an output. Writing a logic 1 to a DDRC bit enables the output buffer for the corresponding port C pin; a logic 0 disables the output buffer.

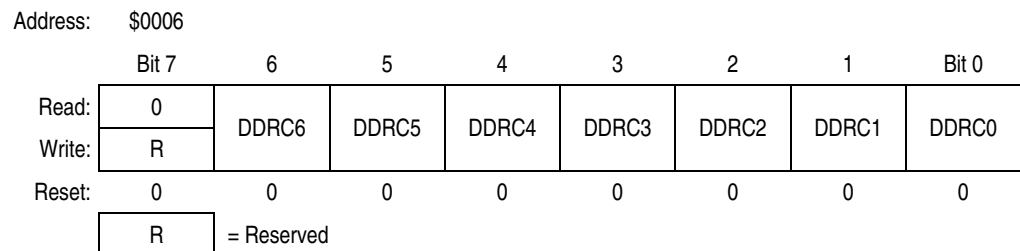

Figure 10-9. Data Direction Register C (DDRC)

DDRC[6:0] — Data Direction Register C Bits

These read/write bits control port C data direction. Reset clears DDRC[6:0], configuring all port C pins as inputs.

- 1 = Corresponding port C pin configured as output
- 0 = Corresponding port C pin configured as input

NOTE: Avoid glitches on port C pins by writing to the port C data register before changing data direction register C bits from 0 to 1.

Figure 10-10 shows the port C I/O logic.

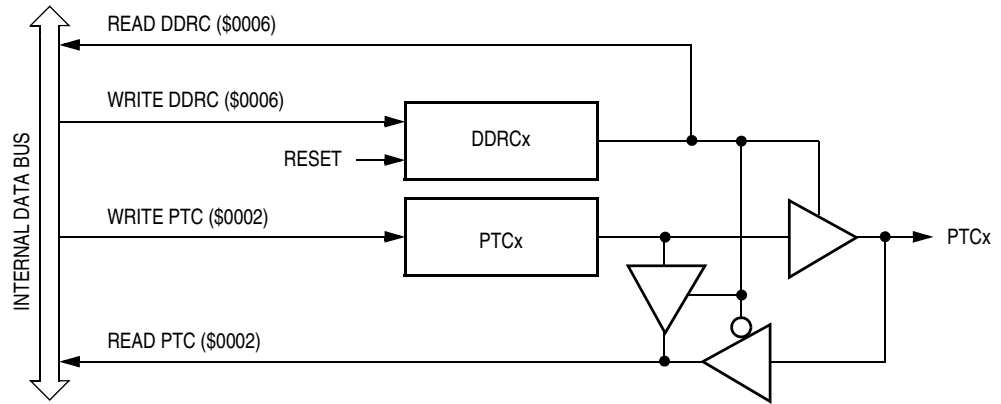

Figure 10-10. Port C I/O Circuit

When bit DDRCx is a logic 1, reading address \$0002 reads the PTCx data latch. When bit DDRCx is a logic 0, reading address \$0002 reads the voltage level on the pin. The data latch can always be written, regardless of the state of its data direction bit. Table 10-3 summarizes the operation of the port C pins.

Table 10-3. Port C Pin Functions

DDRC Bit	PTC Bit	I/O Pin Mode	Accesses to DDRC		
			Read/Write	Read	Write
0	X ⁽¹⁾	Input, Hi-Z ⁽²⁾	DDRC[6:0]	Pin	PTC[6:0] ⁽³⁾
1	X	Output	DDRC[6:0]	PTC[6:0]	PTC[6:0]

1. X = don't care
2. Hi-Z = high impedance
3. Writing affects data register, but does not affect input.

10.5 Port D

Port D is a 7-bit, input-only port that shares its pins with the pulse width modulator for motor control module (PMC).

The port D data register (PTD) contains a data latch for each of the seven port pins.

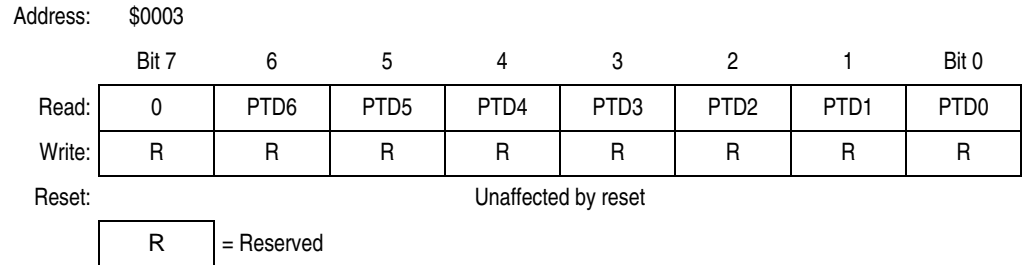

Figure 10-11. Port D Data Register (PTD)

PTD[6:0] — Port D Data Bits

These read/write bits are software programmable. Reset has no effect on port D data.

Figure 10-12 shows the port D input logic.

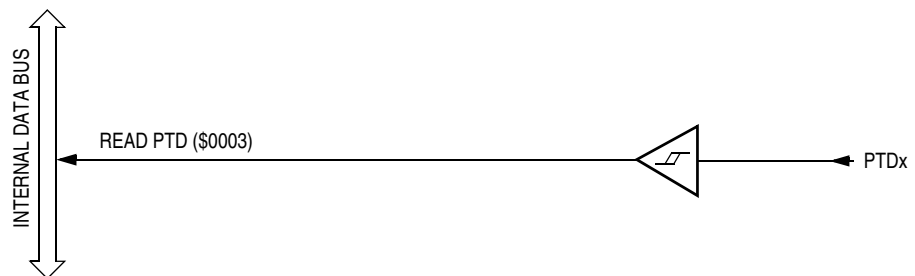

Figure 10-12. Port D Input Circuit

Reading address \$0003 reads the voltage level on the pin. Table 10-4 summarizes the operation of the port D pins.

Table 10-4. Port D Pin Functions

PTD Bit	Pin Mode	Accesses to PTD	
		Read	Write
X ⁽¹⁾	Input, Hi-Z ⁽²⁾	Pin	PTD[6:0] ⁽³⁾

1. X = don't care
2. Hi-Z = high impedance
3. Writing affects data register, but does not affect input.

10.6 Port E

Port E is an 8-bit, special function port that shares five of its pins with the timer interface module (TIM) and two of its pins with the serial communications interface module (SCI).

10.6.1 Port E Data Register

The port E data register (PTE) contains a data latch for each of the eight port E pins.

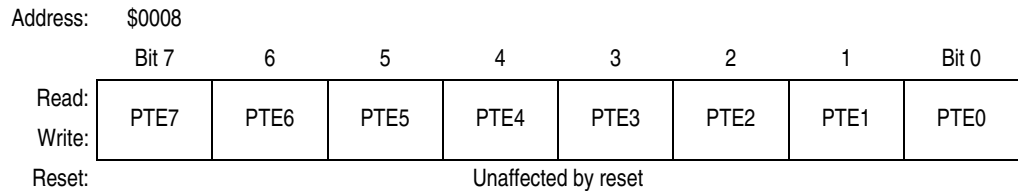

Figure 10-13. Port E Data Register (PTE)

PTE[7:0] — Port E Data Bits

PTE[7:0] are read/write, software-programmable bits. Data direction of each port E pin is under the control of the corresponding bit in data direction register E.

NOTE: Data direction register E (DDRE) does not affect the data direction of port E pins that are being used by the TIMA or TIMB. However, the DDRE bits always determine whether reading port E returns the states of the latches or the states of the pins.

10.6.2 Data Direction Register E

Data direction register E (DDRE) determines whether each port E pin is an input or an output. Writing a logic 1 to a DDRE bit enables the output buffer for the corresponding port E pin; a logic 0 disables the output buffer.

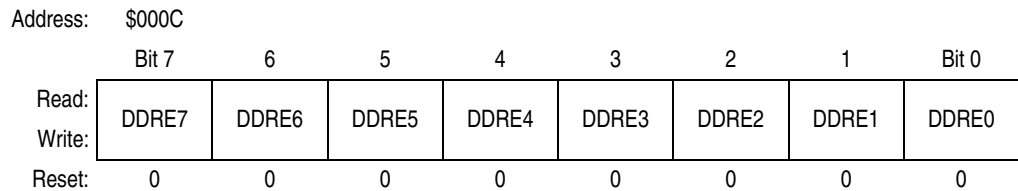

Figure 10-14. Data Direction Register E (DDRE)

DDRE[7:0] — Data Direction Register E Bits

These read/write bits control port E data direction. Reset clears DDRE[7:0], configuring all port E pins as inputs.

- 1 = Corresponding port E pin configured as output
- 0 = Corresponding port E pin configured as input

NOTE: Avoid glitches on port E pins by writing to the port E data register before changing data direction register E bits from 0 to 1.

Figure 10-15 shows the port E I/O logic.

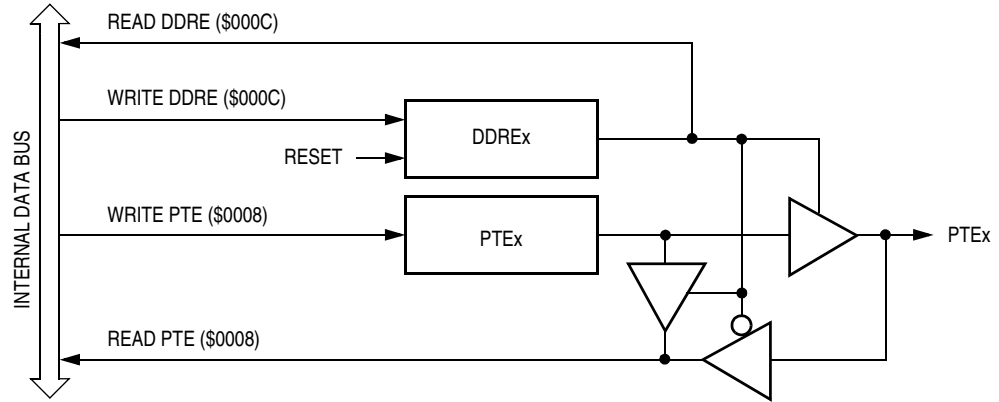

Figure 10-15. Port E I/O Circuit

When bit DDREx is a logic 1, reading address \$0008 reads the PTEx data latch. When bit DDREx is a logic 0, reading address \$0008 reads the voltage level on the pin. The data latch can always be written, regardless of the state of its data direction bit. Table 10-5 summarizes the operation of the port E pins.

Table 10-5. Port E Pin Functions

DDRE Bit	PTE Bit	I/O Pin Mode	Accesses to DDRE		
			Read/Write	Read	Write
0	X ⁽¹⁾	Input, Hi-Z ⁽²⁾	DDRE[7:0]	Pin	PTE[7:0] ⁽³⁾
1	X	Output	DDRE[7:0]	PTE[7:0]	PTE[7:0]

1. X = don't care
2. Hi-Z = high impedance
3. Writing affects data register, but does not affect input.

10.7 Port F

Port F is a 6-bit, special function port that shares four of its pins with the serial peripheral interface module (SPI) and two pins with the serial communications interface (SCI).

10.7.1 Port F Data Register

The port F data register (PTF) contains a data latch for each of the six port F pins.

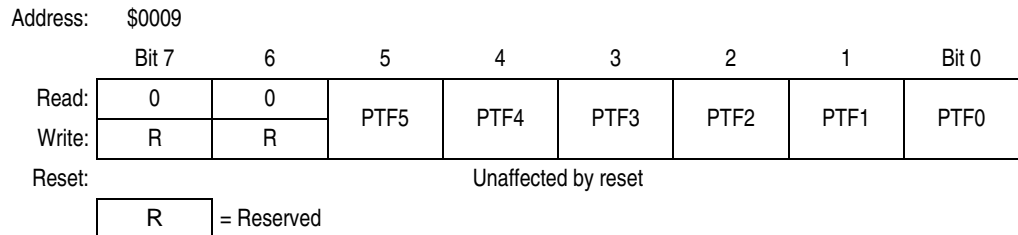

Figure 10-16. Port F Data Register (PTF)

PTF[5:0] — Port F Data Bits

These read/write bits are software programmable. Data direction of each port F pin is under the control of the corresponding bit in data direction register F. Reset has no effect on PTF[5:0].

NOTE: Data direction register F (DDRF) does not affect the data direction of port F pins that are being used by the SPI or SCI module. However, the DDRF bits always determine whether reading port F returns the states of the latches or the states of the pins.

10.7.2 Data Direction Register F

Data direction register F (DDRF) determines whether each port F pin is an input or an output. Writing a logic 1 to a DDRF bit enables the output buffer for the corresponding port F pin; a logic 0 disables the output buffer.

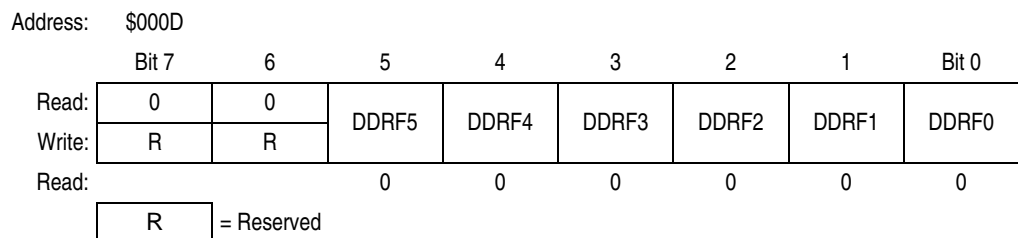

Figure 10-17. Data Direction Register F (DDRF)

DDRF[5:0] — Data Direction Register F Bits

These read/write bits control port F data direction. Reset clears DDRF[5:0], configuring all port F pins as inputs.

- 1 = Corresponding port F pin configured as output
- 0 = Corresponding port F pin configured as input

NOTE: Avoid glitches on port F pins by writing to the port F data register before changing data direction register F bits from 0 to 1.

Figure 10-18 shows the port F I/O logic.

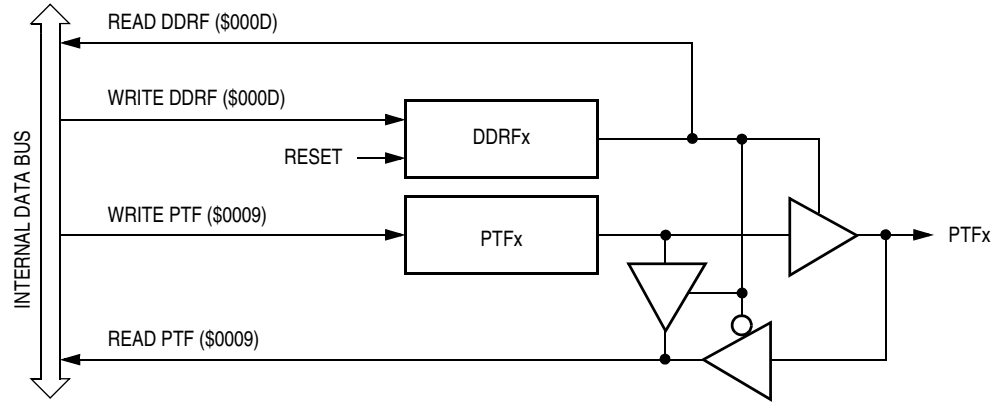

Figure 10-18. Port F I/O Circuit

When bit DDRFx is a logic 1, reading address \$0009 reads the PTFx data latch. When bit DDRFx is a logic 0, reading address \$0009 reads the voltage level on the pin. The data latch can always be written, regardless of the state of its data direction bit. Table 10-6 summarizes the operation of the port F pins.

Table 10-6. Port F Pin Functions

DDRF Bit	PTF Bit	I/O Pin Mode	Accesses to DDRF	Accesses to PTF	
			Read/Write	Read	Write
0	X ⁽¹⁾	Input, Hi-Z ⁽²⁾	DDRF[6:0]	Pin	PTF[6:0] ⁽³⁾
1	X	Output	DDRF[6:0]	PTF[6:0]	PTF[6:0]

1. X = don't care
2. Hi-Z = high impedance
3. Writing affects data register, but does not affect input.

Section 11. Power-On Reset (POR)

11.1 Introduction

This section describes the power-on reset (POR) module.

11.2 Functional Description

The POR module provides a known, stable signal to the microcontroller unit (MCU) at power-on. This signal tracks V_{DD} until the MCU generates a feedback signal to indicate that it is properly initialized. At this time, the POR drives its output low.

The POR is not a brown-out detector, low-voltage detector, or glitch detector. V_{DD} at the POR must go completely to 0 to reset the microcontroller unit (MCU). To detect power-loss conditions, use a low-voltage inhibit module (LVI) or other suitable circuit.

Section 12. Pulse-Width Modulator for Motor Control (PWMMC)

12.1 Introduction

This section describes the pulse-width modulator for motor control (PWMMC, version A). The PWM module can generate three complementary PWM pairs or six independent PWM signals. These PWM signals can be center-aligned or edge-aligned. A block diagram of the PWM module is shown in [Figure 12-2](#).

A 12-bit timer PWM counter is common to all six channels. PWM resolution is one clock period for edge-aligned operation and two clock periods for center-aligned operation. The clock period is dependent on the internal operating frequency (f_{OP}) and a programmable prescaler. The highest resolution for edge-aligned operation is 125 ns ($f_{OP} = 8$ MHz). The highest resolution for center-aligned operation is 250 ns ($f_{OP} = 8$ MHz).

When generating complementary PWM signals, the module features automatic dead-time insertion to the PWM output pairs and transparent toggling of PWM data based upon sensed motor phase current polarity.

A summary of the PWM registers is shown in [Figure 12-3](#).

12.2 Features

Features of the PWMMC include:

- Three complementary PWM pairs or six independent PWM signals
- Edge-aligned PWM signals or center-aligned PWM signals
- PWM signal polarity control
- 20-mA current sink capability on PWM pins
- Manual PWM output control through software
- Programmable fault protection
- Complementary mode featuring:
 - Dead-time insertion
 - Separate top/bottom pulse width correction via current sensing or programmable software bits

Pulse-Width Modulator for Motor Control (PWMMC)

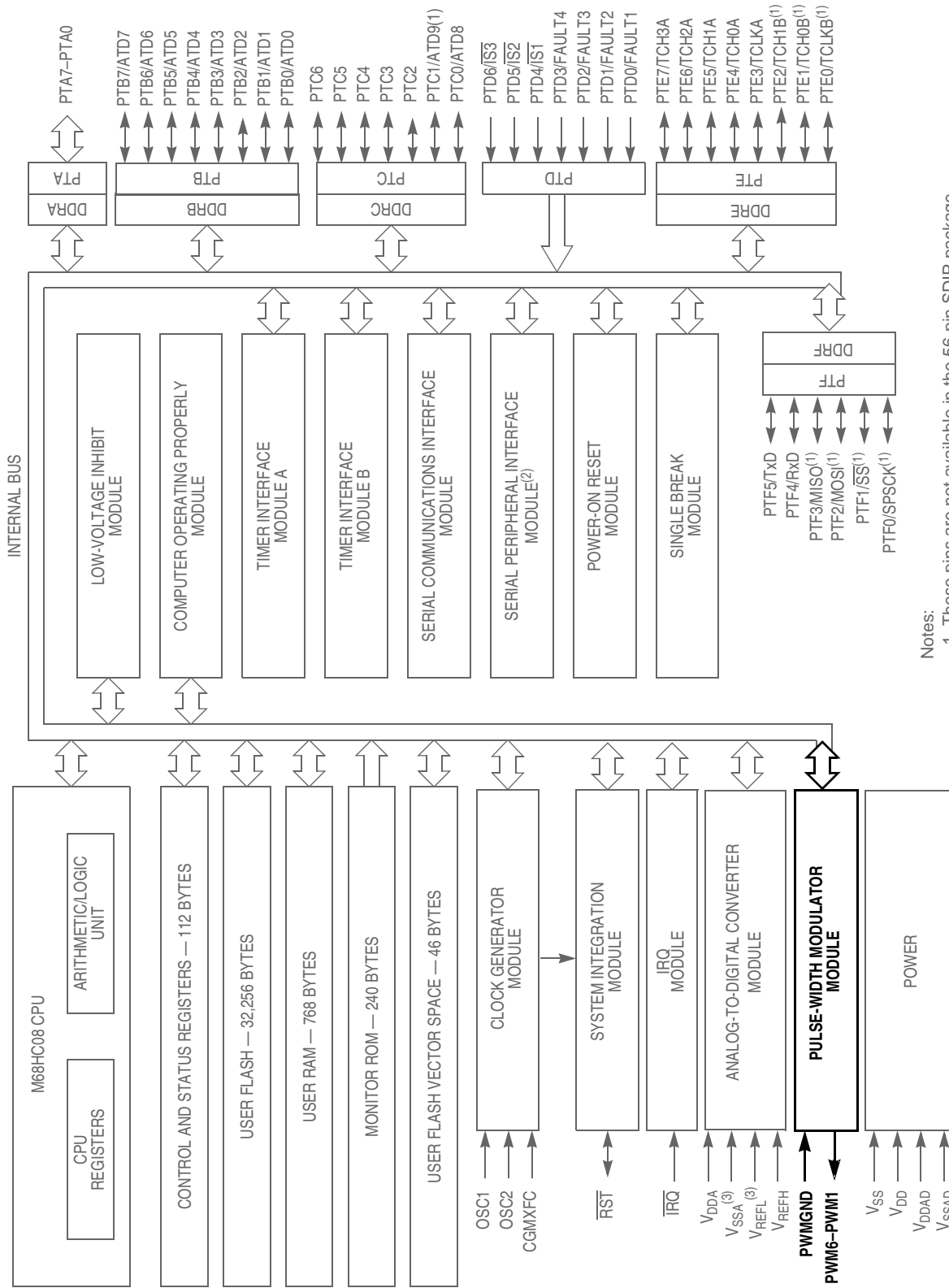

Notes:
 1. These pins are not available in the 56-pin SDIP package.
 2. This module is not available in the 56-pin SDIP package.
 3. In the 56-pin SDIP package, these pins are bonded together.

Figure 12-1. Block Diagram Highlighting PWMMC Block and Pins

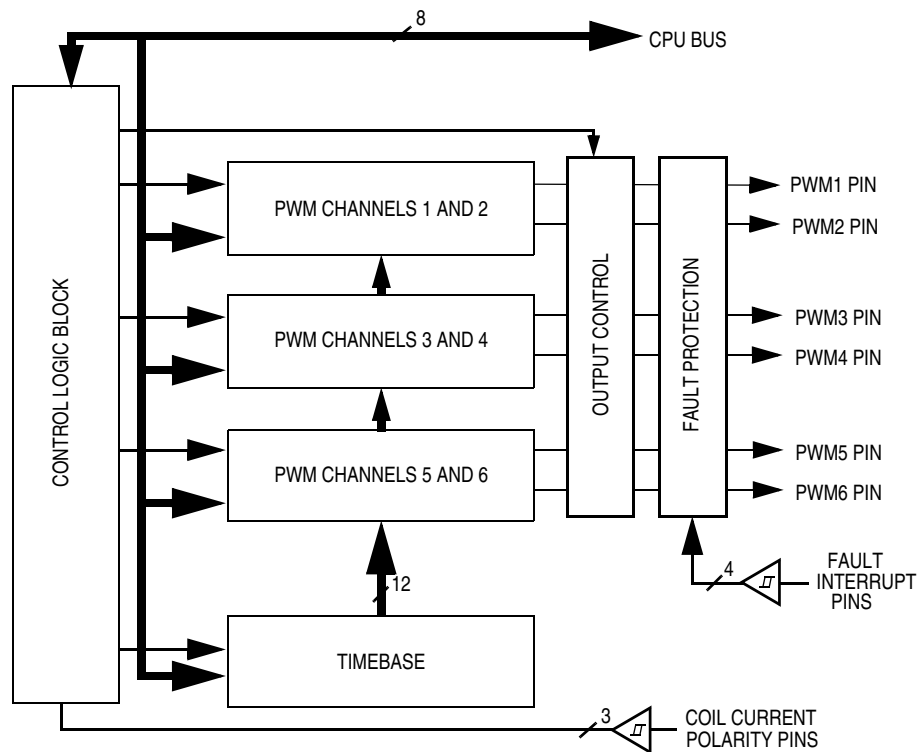

Figure 12-2. PWM Module Block Diagram

Addr.	Register Name	Bit 7	6	5	4	3	2	1	Bit 0	
\$0020	PWM Control Register 1 (PCTL1) See page 158.	Read:	DISX	DISY	PWMINT	PWMF	ISENS1	ISENS0	LDOK	PWMEN
		Write:								
		Reset:	0	0	0	0	0	0	0	0
\$0021	PWM Control Register 2 (PCTL2) See page 160.	Read:	LDFQ1	LDFQ0	0	IPOL1	IPOL2	IPOL3	PRSC1	PRSC0
		Write:								
		Reset:	0	0	0	0	0	0	0	0
\$0022	Fault Control Register (FCR) See page 162.	Read:	FINT4	FMODE4	FINT3	FMODE3	FINT2	FMODE2	FINT1	FMODE1
		Write:								
		Reset:	0	0	0	0	0	0	0	0
\$0023	Fault Status Register (FSR) See page 164.	Read:	FPIN4	FFLAG4	FPIN3	FFLAG3	FPIN2	FFLAG2	FPIN1	FFLAG1
		Write:								
		Reset:	U	0	U	0	U	0	U	0

R = Reserved
 = Buffered
 X = Indeterminate

Figure 12-3. Register Summary (Sheet 1 of 3)

Pulse-Width Modulator for Motor Control (PWMMC)

Addr.	Register Name	Bit 7	6	5	4	3	2	1	Bit 0	
\$0024	Fault Acknowledge Register (FTACK) See page 165.	Read:	0	0	DT6	DT5	DT4	DT3	DT2	DT1
		Write:		FTACK4		FTACK3		FTACK2		FTACK1
		Reset:	0	0	0	0	0	0	0	0
\$0025	PWM Output Control Register (PWMOUT) See page 166.	Read:	0	OUTCTL	OUT6	OUT5	OUT4	OUT3	OUT2	OUT1
		Write:								
		Reset:	0	0	0	0	0	0	0	0
\$0026	PWM Counter Register High (PCNTH) See page 156.	Read:	0	0	0	0	Bit 11	Bit 10	Bit 9	Bit 8
		Write:								
		Reset:	0	0	0	0	0	0	0	0
\$0027	PWM Counter Register Low (PCNTL) See page 156.	Read:	Bit 7	Bit 6	Bit 5	Bit 4	Bit 3	Bit 2	Bit 1	Bit 0
		Write:								
		Reset:	0	0	0	0	0	0	0	0
\$0028	PWM Counter Modulo Register High (PMODH) See page 156.	Read:	0	0	0	0	Bit 11	Bit 10	Bit 9	Bit 8
		Write:								
		Reset:	0	0	0	0	X	X	X	X
\$0029	PWM Counter Modulo Register Low (PMDL) See page 156.	Read:	Bit 7	Bit 6	Bit 5	Bit 4	Bit 3	Bit 2	Bit 1	Bit 0
		Write:								
		Reset:	X	X	X	X	X	X	X	X
\$002A	PWM 1 Value Register High (PVAL1H) See page 157.	Read:	Bit 15	Bit 14	Bit 13	Bit 12	Bit 11	Bit 10	Bit 9	Bit 8
		Write:								
		Reset:	0	0	0	0	0	0	0	0
\$002B	PWM 1 Value Register Low (PVAL1L) See page 157.	Read:	Bit 7	Bit 6	Bit 5	Bit 4	Bit 3	Bit 2	Bit 1	Bit 0
		Write:								
		Reset:	0	0	0	0	0	0	0	0
\$002C	PWM 2 Value Register High (PVAL2H) See page 157.	Read:	Bit 15	Bit 14	Bit 13	Bit 12	Bit 11	Bit 10	Bit 9	Bit 8
		Write:								
		Reset:	0	0	0	0	0	0	0	0
\$002D	PWM 2 Value Register Low (PVAL2L) See page 157.	Read:	Bit 7	Bit 6	Bit 5	Bit 4	Bit 3	Bit 2	Bit 1	Bit 0
		Write:								
		Reset:	0	0	0	0	0	0	0	0

R = Reserved Bold = Buffered X = Indeterminate

Figure 12-3. Register Summary (Sheet 2 of 3)

Addr.	Register Name	Bit 7	6	5	4	3	2	1	Bit 0	
\$002E	PWM 3 Value Register High (PVAL3H) See page 157.	Read:								
		Write:	Bit 15	Bit 14	Bit 13	Bit 12	Bit 11	Bit 10	Bit 9	Bit 8
		Reset:	0	0	0	0	0	0	0	0
\$002F	PWM 3 Value Register Low (PVAL3L) See page 157.	Read:								
		Write:	Bit 7	Bit 6	Bit 5	Bit 4	Bit 3	Bit 2	Bit 1	Bit 0
		Reset:	0	0	0	0	0	0	0	0
\$0030	PWM 4 Value Register High (PVAL4H) See page 157.	Read:								
		Write:	Bit 15	Bit 14	Bit 13	Bit 12	Bit 11	Bit 10	Bit 9	Bit 8
		Reset:	0	0	0	0	0	0	0	0
\$0031	PWM 4 Value Register Low (PVAL4L) See page 157.	Read:								
		Write:	Bit 7	Bit 6	Bit 5	Bit 4	Bit 3	Bit 2	Bit 1	Bit 0
		Reset:	0	0	0	0	0	0	0	0
\$0032	PWM 5 Value Register High (PVAL5H) See page 157.	Read:								
		Write:	Bit 15	Bit 14	Bit 13	Bit 12	Bit 11	Bit 10	Bit 9	Bit 8
		Reset:	0	0	0	0	0	0	0	0
\$0033	PWM 5 Value Register Low (PVAL5L) See page 157.	Read:								
		Write:	Bit 7	Bit 6	Bit 5	Bit 4	Bit 3	Bit 2	Bit 1	Bit 0
		Reset:	0	0	0	0	0	0	0	0
\$0034	PWM 6 Value Register High (PVAL6H) See page 157.	Read:								
		Write:	Bit 15	Bit 14	Bit 13	Bit 12	Bit 11	Bit 10	Bit 9	Bit 8
		Reset:	0	0	0	0	0	0	0	0
\$0035	PWM 6 Value Register Low (PVAL6L) See page 157.	Read:								
		Write:	Bit 7	Bit 6	Bit 5	Bit 4	Bit 3	Bit 2	Bit 1	Bit 0
		Reset:	0	0	0	0	0	0	0	0
\$0036	Dead-Time Write-Once Register (DEADTM) See page 162.	Read:								
		Write:	Bit 7	Bit 6	Bit 5	Bit 4	Bit 3	Bit 2	Bit 1	Bit 0
		Reset:	1	1	1	1	1	1	1	1
\$0037	PWM Disable Mapping Write-Once Register (DISMAP) See page 162.	Read:								
		Write:	Bit 7	Bit 6	Bit 5	Bit 4	Bit 3	Bit 2	Bit 1	Bit 0
		Reset:	1	1	1	1	1	1	1	1

R = Reserved Bold = Buffered X = Indeterminate

Figure 12-3. Register Summary (Sheet 3 of 3)

12.3 Timebase

This section provides a discussion of the timebase.

12.3.1 Resolution

In center-aligned mode, a 12-bit up/down counter is used to create the PWM period. Therefore, the PWM resolution in center-aligned mode is two clocks (highest resolution is 250 ns @ $f_{OP} = 8$ MHz) as shown in **Figure 12-4**. The up/down counter uses the value in the timer modulus register to determine its maximum count. The PWM period will equal:

$$[(\text{timer modulus}) \times (\text{PWM clock period}) \times 2].$$

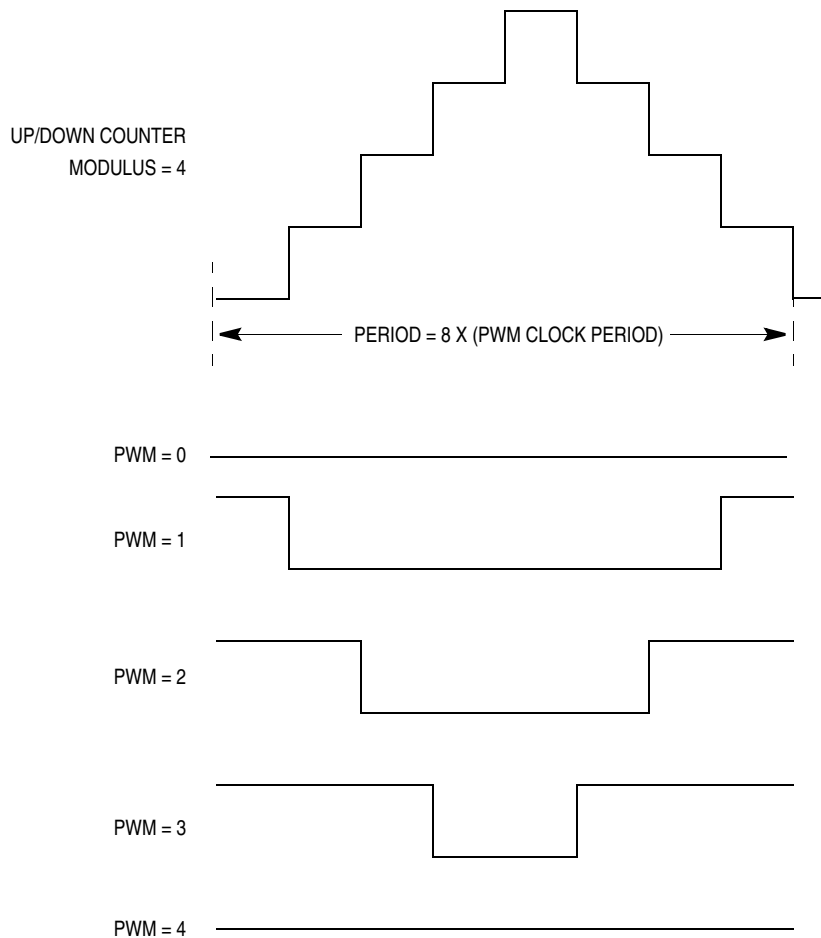

Figure 12-4. Center-Aligned PWM (Positive Polarity)

For edge-aligned mode, a 12-bit up-only counter is used to create the PWM period. Therefore, the PWM resolution in edge-aligned mode is one clock (highest resolution is 125 ns @ $f_{OP} = 8$ MHz) as shown in **Figure 12-5**. Again, the timer modulus register is used to determine the maximum count. The PWM period will equal:

$$(\text{timer modulus}) \times (\text{PWM clock period})$$

Center-aligned operation versus edge-aligned operation is determined by the option EDGE. See **5.2 Functional Description**.

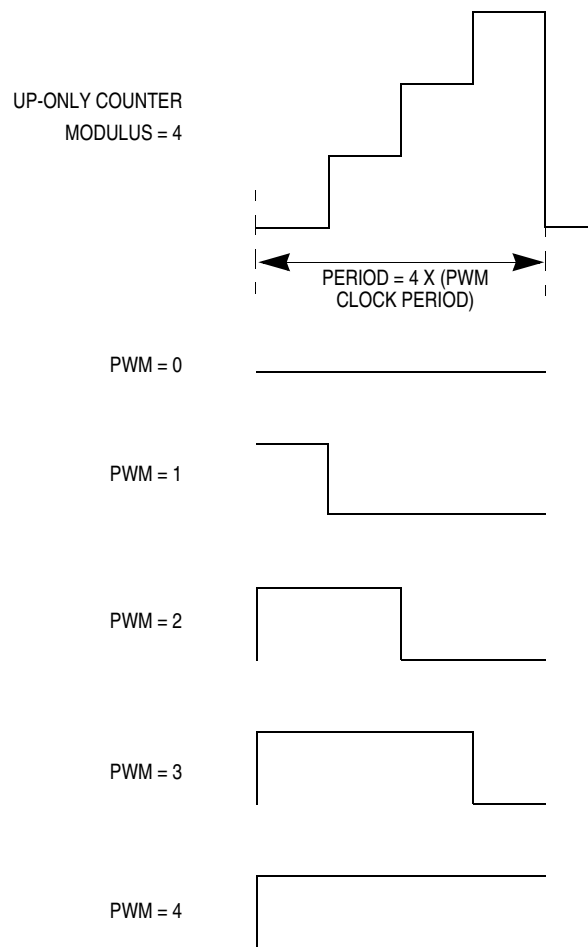

Figure 12-5. Edge-Aligned PWM (Positive Polarity)

12.3.2 Prescaler

To permit lower PWM frequencies, a prescaler is provided which will divide the PWM clock frequency by 1, 2, 4, or 8. **Table 12-1** shows how setting the prescaler bits in PWM control register 2 affects the PWM clock frequency. This prescaler is buffered and will not be used by the PWM generator until the LDOK bit is set and a new PWM reload cycle begins.

Table 12-1. PWM Prescaler

Prescaler Bits PRSC1 and PRSC0	PWM Clock Frequency
00	f_{OP}
01	$f_{OP}/2$
10	$f_{OP}/4$
11	$f_{OP}/8$

12.4 PWM Generators

Pulse-width modulator (PWM) generators are discussed in this subsection.

12.4.1 Load Operation

To help avoid erroneous pulse widths and PWM periods, the modulus, prescaler, and PWM value registers are buffered. New PWM values, counter modulus values, and prescalers can be loaded from their buffers into the PWM module every one, two, four, or eight PWM cycles. LDFQ1 and LDFQ0 in PWM control register 2 are used to control this reload frequency, as shown in **Table 12-2**. When a reload cycle arrives, regardless of whether an actual reload occurs (as determined by the LDOK bit), the PWM reload flag bit in PWM control register 1 will be set. If the PWMINT bit in PWM control register 1 is set, a CPU interrupt request will be generated when PWWF is set. Software can use this interrupt to calculate new PWM parameters in real time for the PWM module.

Table 12-2. PWM Reload Frequency

Reload Frequency Bits LDFQ1 and LDFQ0	PWM Reload Frequency
00	Every PWM cycle
01	Every 2 PWM cycles
10	Every 4 PWM cycles
11	Every 8 PWM cycles

For ease of software, the LDFQx bits are buffered. When the LDFQx bits are changed, the reload frequency will not change until the previous reload cycle is completed. See [Figure 12-6](#).

NOTE: When reading the LDFQx bits, the value is the buffered value (for example, not necessarily the value being acted upon).

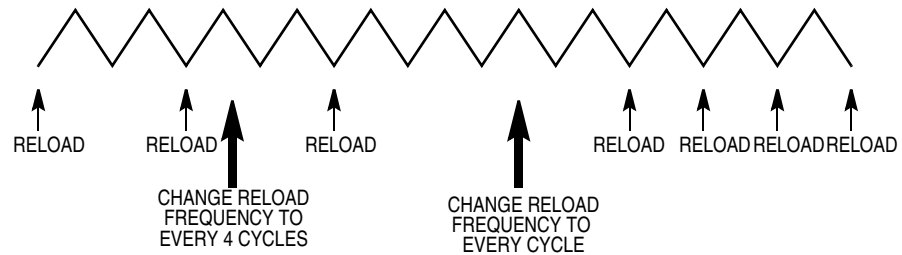

Figure 12-6. Reload Frequency Change

PWMINT enables CPU interrupt requests as shown in [Figure 12-7](#). When this bit is set, CPU interrupt requests are generated when the PWMF bit is set. When the PWMINT bit is clear, PWM interrupt requests are inhibited. PWM reloads will still occur at the reload rate, but no interrupt requests will be generated.

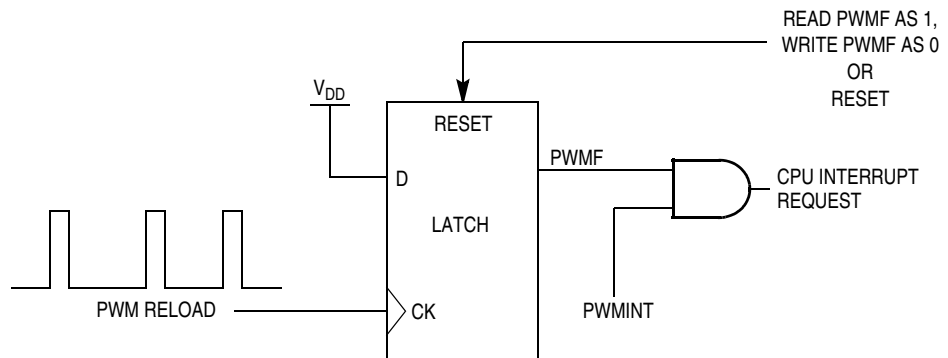

Figure 12-7. PWM Interrupt Requests

To prevent a partial reload of PWM parameters from occurring while the software is still calculating them, an interlock bit controlled from software is provided. This bit informs the PWM module that all the PWM parameters have been calculated, and it is “okay” to use them. A new modulus, prescaler, and/or PWM value cannot be loaded into the PWM module until the LDOK bit in PWM control register 1 is set. When the LDOK bit is set, these new values are loaded into a second set of registers and used by the PWM generator at the beginning of the next PWM reload cycle as shown in [Figure 12-8](#), [Figure 12-9](#), [Figure 12-10](#), and [Figure 12-11](#). After these values are loaded, the LDOK bit is cleared.

NOTE: When the PWM module is enabled (via the PWMEN bit), a load will occur if the LDOK bit is set. Even if it is not set, an interrupt will occur if the PWMINT bit is set.

To prevent this, the software should clear the PWMINT bit before enabling the PWM module.

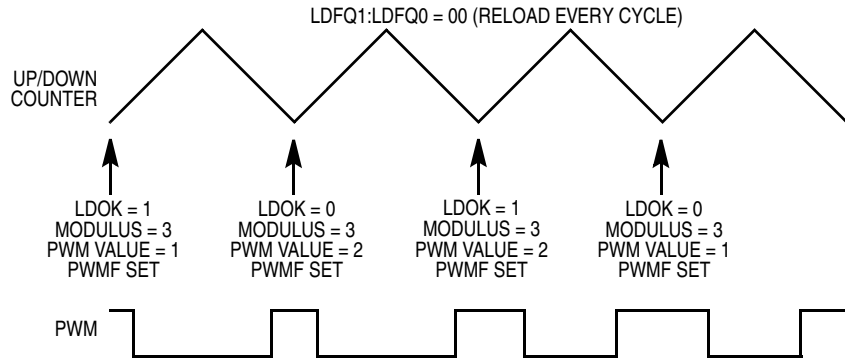

Figure 12-8. Center-Aligned PWM Value Loading

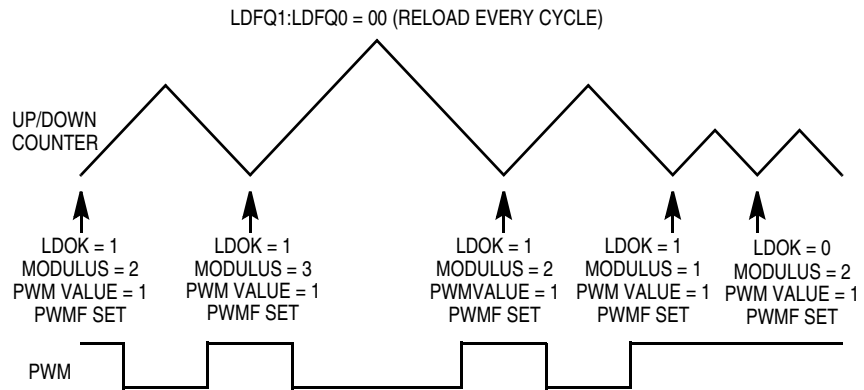

Figure 12-9. Center-Aligned Loading of Modulus

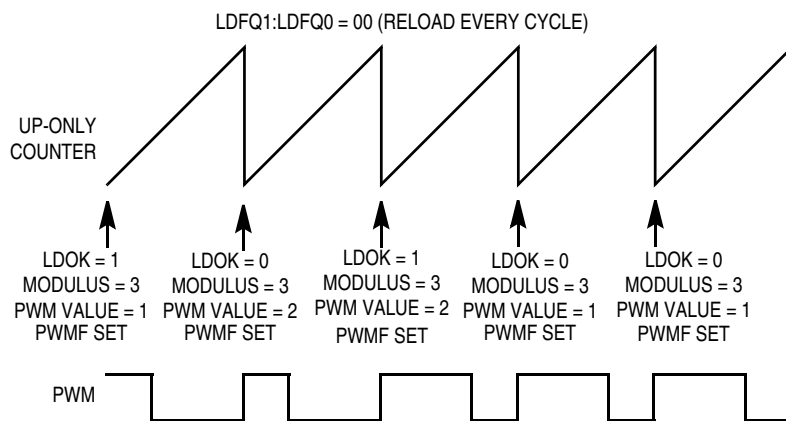

Figure 12-10. Edge-Aligned PWM Value Loading

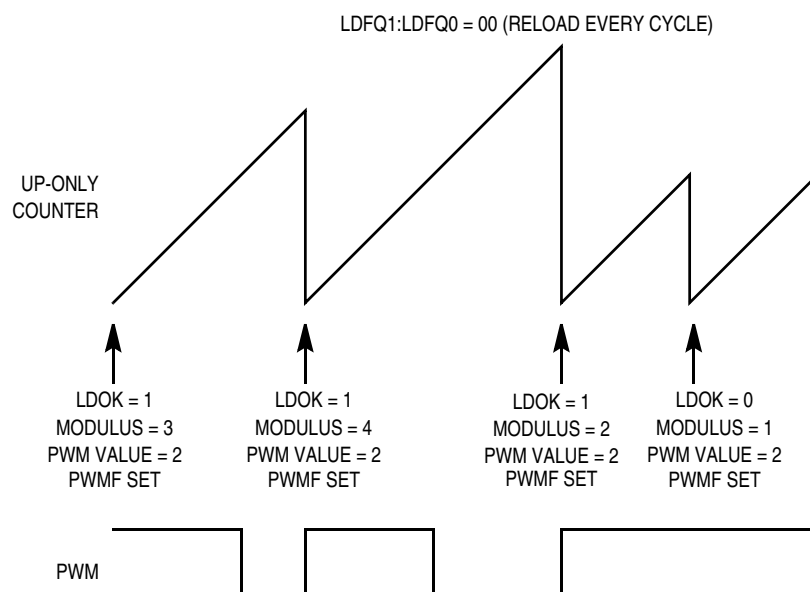

Figure 12-11. Edge-Aligned Modulus Loading

12.4.2 PWM Data Overflow and Underflow Conditions

The PWM value registers are 16-bit registers. Although the counter is only 12 bits, the user may write a 16-bit signed value to a PWM value register. As shown in [Figure 12-4](#) and [Figure 12-5](#), if the PWM value is less than or equal to zero, the PWM will be inactive for the entire period. Conversely, if the PWM value is greater than or equal to the timer modulus, the PWM will be active for the entire period. Refer to [Table 12-3](#).

NOTE: *The terms “active” and “inactive” refer to the asserted and negated states of the PWM signals and should not be confused with the high-impedance state of the PWM pins.*

Table 12-3. PWM Data Overflow and Underflow Conditions

PWMVALxH:PWMVALxL	Condition	PWM Value Used
\$0000–\$0FFF	Normal	Per register contents
\$1000–\$7FFF	Overflow	\$FFF
\$8000–\$FFFF	Underflow	\$000

12.5 Output Control

This subsection discusses output control.

12.5.1 Selecting Six Independent PWMs or Three Complementary PWM Pairs

The PWM outputs can be configured as six independent PWM channels or three complementary channel pairs. The option INDEP determines which mode is used (see [5.2 Functional Description](#)). If complementary operation is chosen, the PWM pins are paired as shown in [Figure 12-12](#). Operation of one pair is then determined by one PWM value register. This type of operation is meant for use in motor drive circuits such as the one in [Figure 12-13](#).

When complementary operation is used, two additional features are provided:

- Dead-time insertion
- Separate top/bottom pulse width correction to correct for distortions caused by the motor drive characteristics

If independent operation is chosen, each PWM has its own PWM value register.

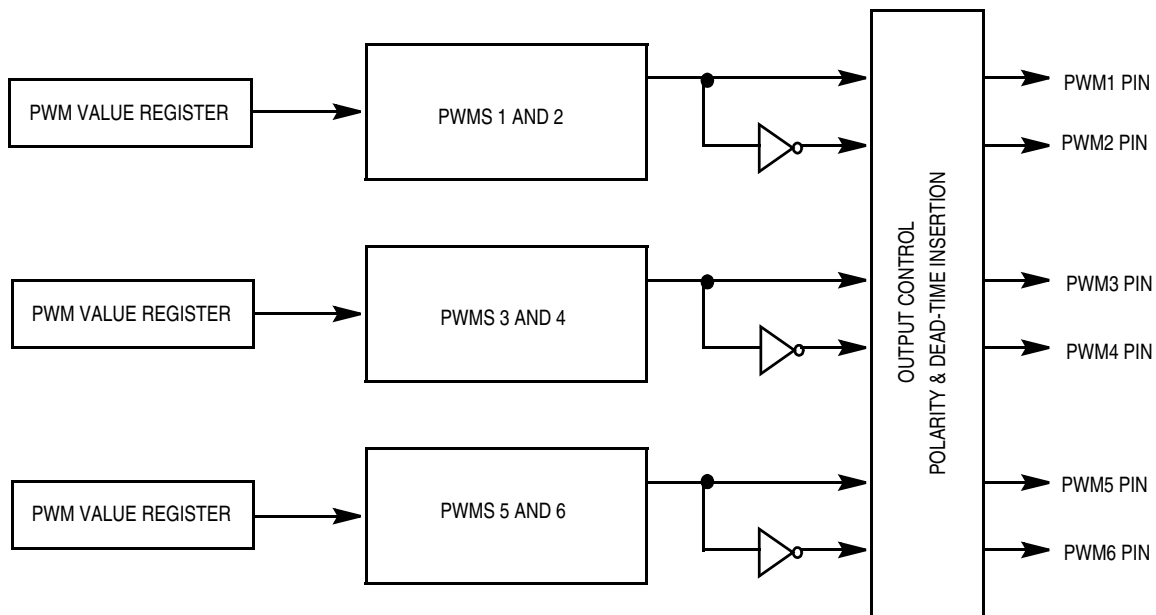

Figure 12-12. Complementary Pairing

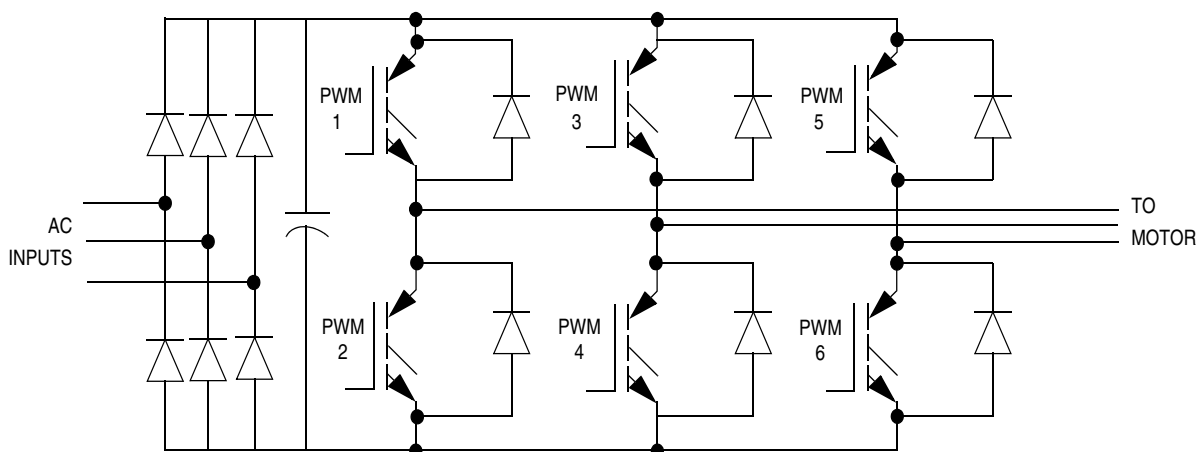

Figure 12-13. Typical AC Motor Drive

12.5.2 Dead-Time Insertion

As shown in [Figure 12-13](#), in complementary mode, each PWM pair can be used to drive top-side/bottom-side transistors.

When controlling dc-to-ac inverters such as this, the top and bottom PWMs in one pair should *never* be active at the same time. In [Figure 12-13](#), if PWM1 and PWM2 were on at the same time, large currents would flow through the two transistors as they discharge the bus capacitor. The IGBTs could be weakened or destroyed.

Simply forcing the two PWMs to be inversions of each other is not always sufficient. Since a time delay is associated with turning off the transistors in the motor drive, there must be a dead-time between the deactivation of one PWM and the activation of the other.

A dead-time can be specified in the dead-time write-once register. This 8-bit value specifies the number of CPU clock cycles to use for the dead-time. The dead-time is not affected by changes in the PWM period caused by the prescaler.

Dead-time insertion is achieved by feeding the top PWM outputs of the PWM generator into dead-time generators, as shown in [Figure 12-14](#). Current sensing determines which PWM value of a PWM generator pair to use for the top PWM in the next PWM cycle. See [12.5.3 Top/Bottom Correction with Motor Phase Current Polarity Sensing](#). When output control is enabled, the odd OUT bits, rather than the PWM generator outputs, are fed into the dead-time generators. See [12.5.5 PWM Output Port Control](#).

Pulse-Width Modulator for Motor Control (PWMMC)

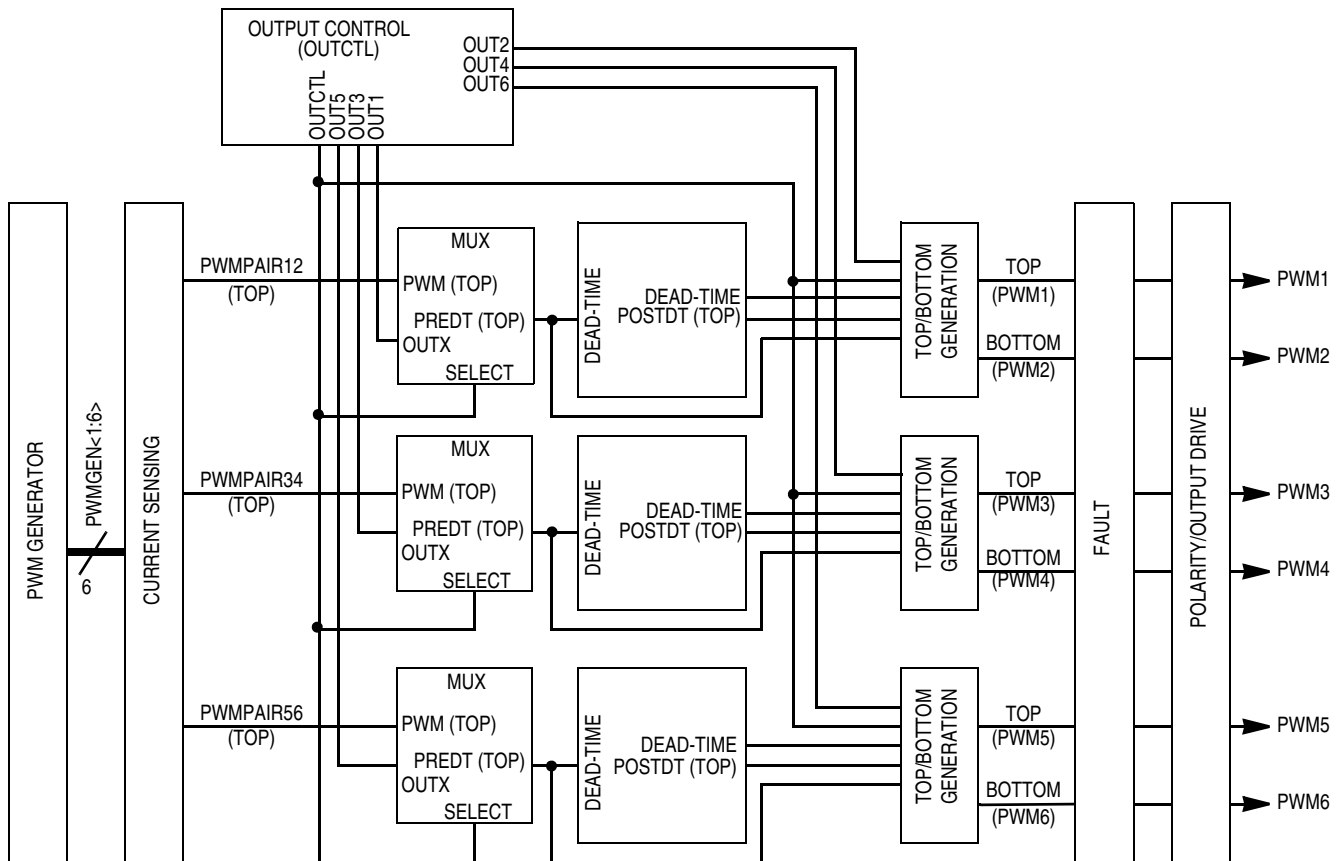

Figure 12-14. Dead-Time Generators

Whenever an input to a dead-time generator transitions, a dead-time is inserted (for example, both PWMs in the pair are forced to their inactive state). The bottom PWM signal is generated from the top PWM and the dead-time. In the case of output control enabled, the odd OUTx bits control the top PWMs, the even OUTx bits control the bottom PWMs *with respect to the odd OUTx bits* (see [Table 12-6](#)). [Figure 12-15](#) shows the effects of the dead-time insertion.

As seen in [Figure 12-15](#), some pulse width distortion occurs when the dead-time is inserted. The active pulse widths are reduced. For example, in [Figure 12-15](#), when the PWM value register is equal to two, the ideal waveform (with no dead-time) has pulse widths equal to four. However, the actual pulse widths shrink to two after a dead-time of two was inserted. In this example, with the prescaler set to divide by one and center-aligned operation selected, this distortion can be compensated for by adding or subtracting half the dead-time value to or from the PWM register value. This correction is further described in [12.5.3 Top/Bottom Correction with Motor Phase Current Polarity Sensing](#).

Further examples of dead-time insertion are shown in [Figure 12-16](#) and [Figure 12-17](#). [Figure 12-16](#) shows the effects of dead-time insertion at the duty cycle

boundaries (near 0 percent and 100 percent duty cycles). **Figure 12-17** shows the effects of dead-time insertion on pulse widths smaller than the dead-time.

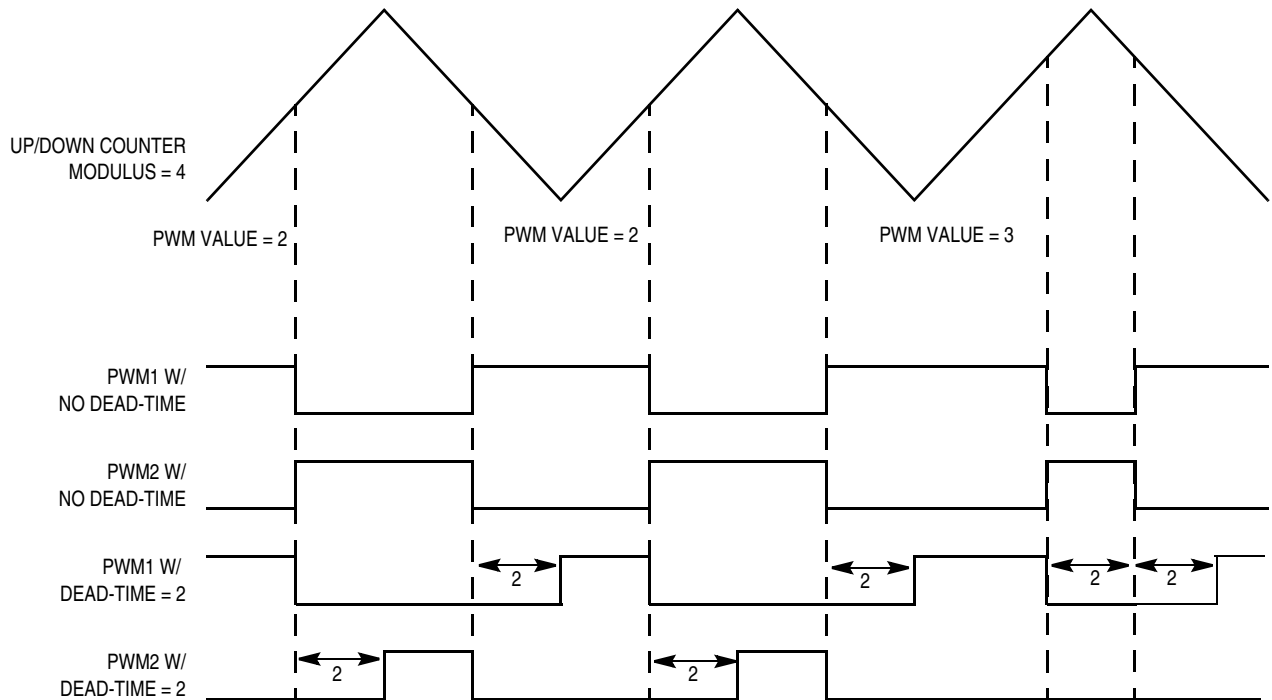

Figure 12-15. Effects of Dead-Time Insertion

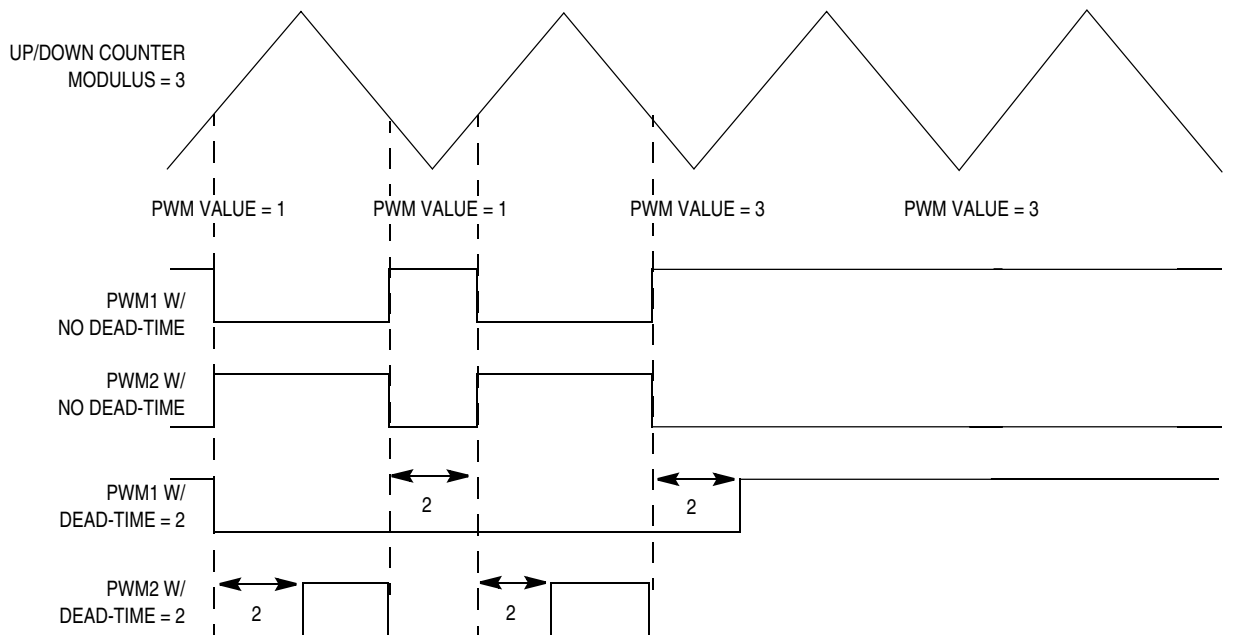

Figure 12-16. Dead-Time at Duty Cycle Boundaries

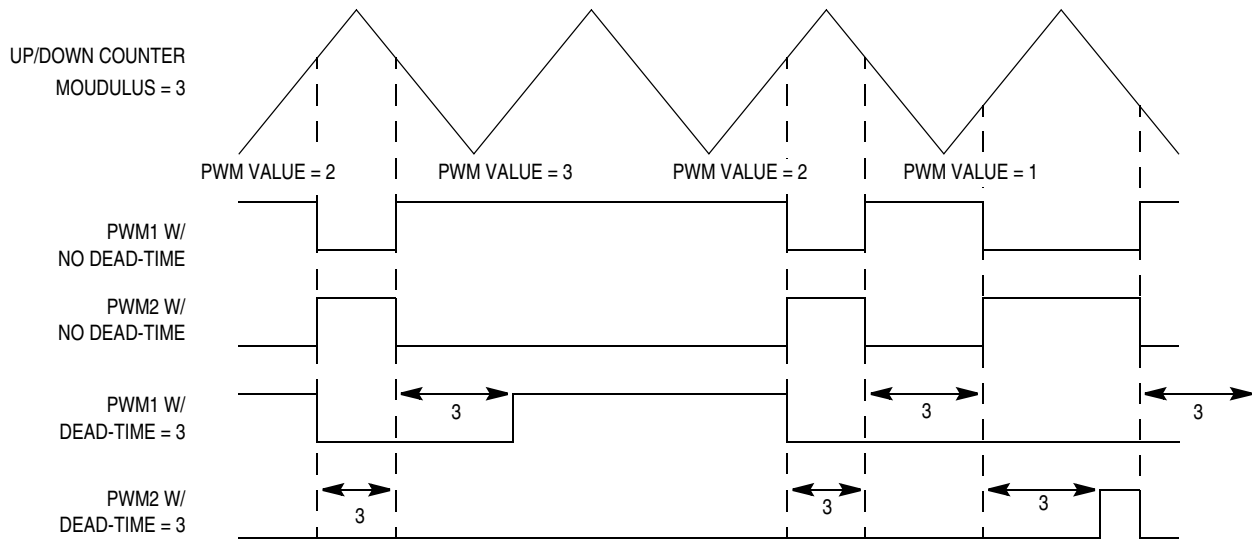

Figure 12-17. Dead-Time and Small Pulse Widths

12.5.3 Top/Bottom Correction with Motor Phase Current Polarity Sensing

Ideally, when complementary pairs are used, the PWM pairs are inversions of each other, as shown in Figure 12-18. When PWM1 is active, PWM2 is inactive, and vice versa. In this case, the motor terminal voltage is never allowed to float and is strictly controlled by the PWM waveforms.

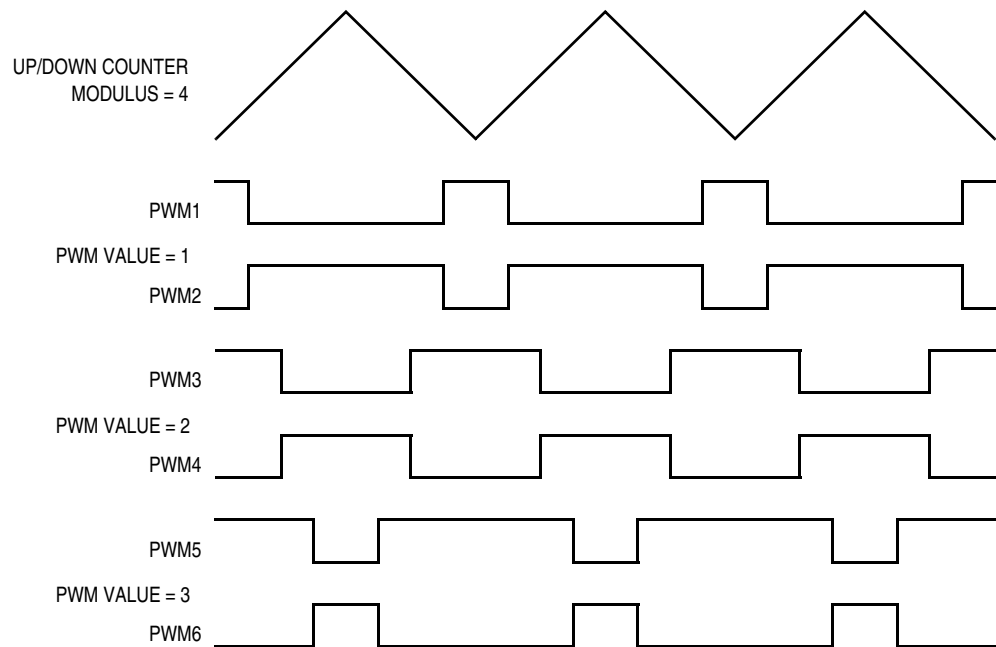

Figure 12-18. Ideal Complementary Operation (Dead-Time = 0)

However, when dead-time is inserted, the motor voltage is allowed to float momentarily during the dead-time interval, creating a distortion in the motor current waveform. This distortion is aggravated by dissimilar turn-on and turn-off delays of each of the transistors.

For a typical motor drive inverter as shown in [Figure 12-13](#), for a given top/bottom transistor pair, only one of the transistors will be effective in controlling the output voltage at any given time depending on the direction of the motor current for that pair. To achieve distortion correction, one of two different correction factors must be added to the desired PWM value, depending on whether the top or bottom transistor is controlling the output voltage. Therefore, the software is responsible for calculating both compensated PWM values and placing them in an odd/even PWM register pair. By supplying the PWM module with information regarding which transistor (top or bottom) is controlling the output voltage at any given time (for instance, the current polarity for that motor phase), the PWM module selects either the odd or even numbered PWM value register to be used by the PWM generator.

Current sensing or programmable software bits are then used to determine which PWM value to use. If the current sensed at the motor for that PWM pair is positive (voltage on current pin ISx is low) or bit IPOLx in PWM control register 2 is low, the top PWM value is used for the PWM pair. Likewise, if the current sensed at the motor for that PWM pair is negative (voltage on current pin ISx is high) or bit IPOLx in PWM control register 2 is high, the bottom PWM value is used. See [Table 12-4](#).

NOTE: *This text assumes the user will provide current sense circuitry which causes the voltage at the corresponding input pin to be low for positive current and high for negative current. See [Figure 12-19](#) for current convention. In addition, it assumes the top PWMs are PWMs 1, 3, and 5 while the bottom PWMs are PWMs 2, 4, and 6.*

Table 12-4. Current Sense Pins

Current Sense Pin or Bit	Voltage on Current Sense Pin or IPOLx Bit	PWM Value Register Used	PWMs Affected
$\overline{IS1}$ or IPOL1	Logic 0	PWM value register 1	PWMs 1 and 2
$\overline{IS1}$ or IPOL1	Logic 1	PWM value register 2	PWMs 1 and 2

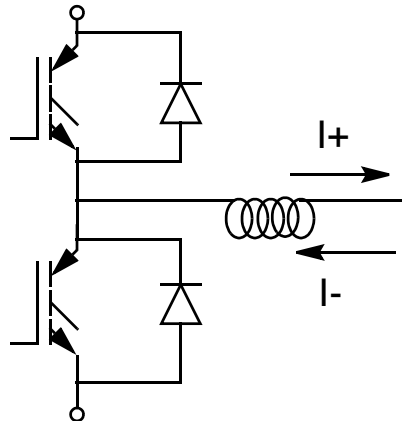

Figure 12-19. Current Convention

To allow for correction based on different current sensing methods or correction controlled by software, the ISENS1 and ISENS0 bits in PWM control register 1 are provided to choose the correction method. These bits provide correction according to [Table 12-5](#).

Table 12-5. Correction Methods

Current Correction Bits ISENS1 and ISENS0	Correction Method
00 01	Bits IPOL1, IPOL2, and IPOL3 used for correction
10	Current sensing on pins $\overline{IS1}$, $\overline{IS2}$, and $\overline{IS3}$ occurs during the dead-time.
11	Current sensing on pins $\overline{IS1}$, $\overline{IS2}$, and $\overline{IS3}$ occurs at the half cycle in center-aligned mode and at the end of the cycle in edge-aligned mode.

If correction is to be done in software or is not necessary, setting ISENS1:ISENS0 = 00 or = 01 causes the correction to be based on bits IPOL1, IPOL2, and IPOL3 in PWM control register 2. If correction is not required, the user can initialize the IPOLx bits and then only load one PWM value register per PWM pair.

To allow the user to use a current sense scheme based upon sensed phase voltage during dead-time, setting ISENS1:ISENS0 = 10 causes the polarity of the Ix pin to be latched when both the top and bottom PWMs are off (for example, during the dead-time). At the 0 percent and 100 percent duty cycle boundaries, there is no dead-time so no new current value is sensed.

To accommodate other current sensing schemes, setting ISENS1:ISENS0 = 11 causes the polarity of the current sense pin to be latched half-way into the PWM cycle in center-aligned mode and at the end of the cycle in edge-aligned mode. Therefore, even at 0 percent and 100 percent duty cycle, the current is sensed.

Distortion correction is only available in complementary mode. At the beginning of the PWM period, the PWM uses this latched current value or polarity bit to decide whether the top PWM value or bottom PWM value is used. **Figure 12-20** shows an example of top/bottom correction for PWMs 1 and 2.

NOTE: *The IPOLx bits and the values latched on the ISx pins are buffered so that only one PWM register is used per PWM cycle. If the IPOLx bits or the current sense values change during a PWM period, this new value will not be used until the next PWM period. The ISENSx bits are NOT buffered; therefore, changing the current sensing method could affect the present PWM cycle.*

When the PWM is first enabled by setting PWMEN, PWM value registers 1, 3, and 5 will be used if the ISENSx bits are configured for current sensing correction. This is because no current will have previously been sensed.

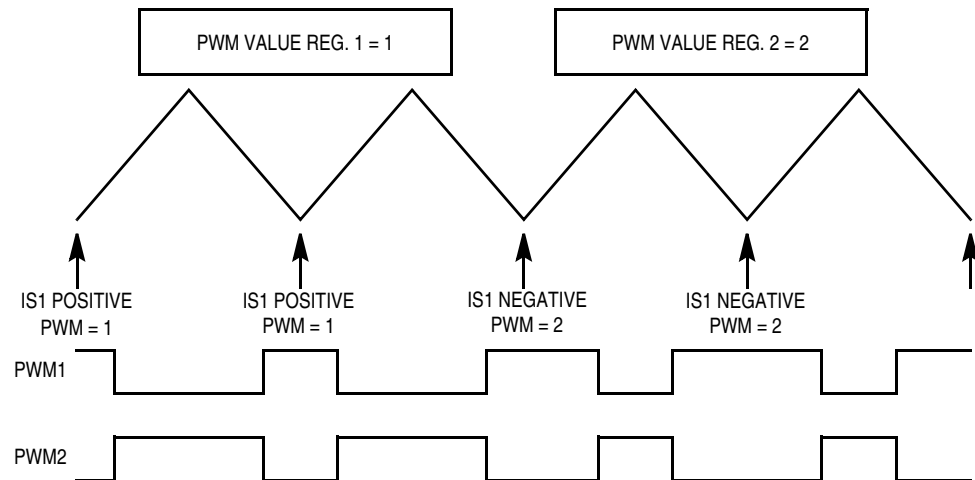

Figure 12-20. Top/Bottom Correction for PWMs 1 and 2

12.5.4 Output Polarity

The output polarity of the PWMs is determined by two options: TOPNEG and BOTNEG. The top polarity option, TOPNEG, controls the polarity of PWMs 1, 3, and 5. The bottom polarity option, BOTNEG, controls the polarity of PWMs 2, 4, and 6. Positive polarity means that when the PWM is active, the PWM output is high. Conversely, negative polarity means that when the PWM is active, PWM output is low. See **Figure 12-21**.

NOTE: *Both bits are found in the CONFIG register, which is a write-once register. This reduces the chances of the software inadvertently changing the polarity of the PWM signals and possibly damaging the motor drive hardware.*

Pulse-Width Modulator for Motor Control (PWMMC)

Freescale Semiconductor, Inc.

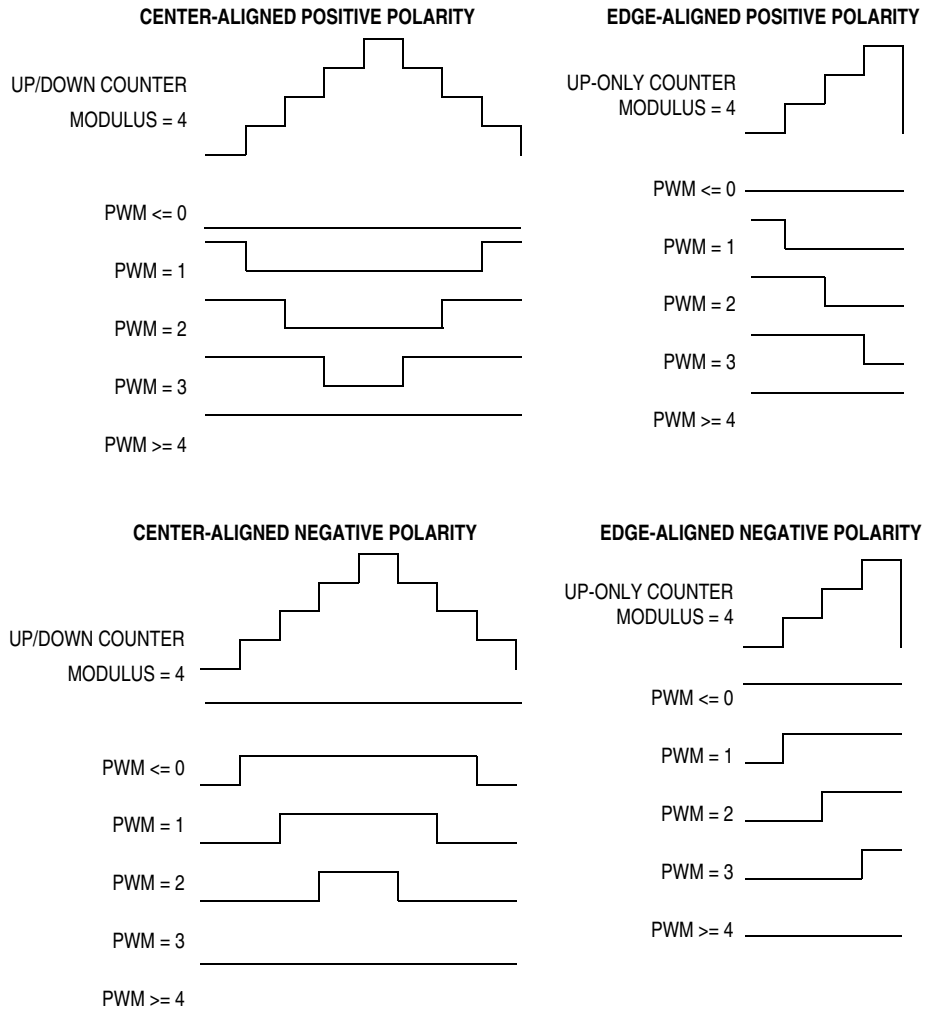

Figure 12-21. PWM Polarity

12.5.5 PWM Output Port Control

Conditions may arise in which the PWM pins need to be individually controlled. This is made possible by the PWM output control register (PWMOUT) shown in Figure 12-22.

Address: \$0025

	Bit 7	6	5	4	3	2	1	Bit 0
Read:	0	OUTCTL	OUT6	OUT5	OUT4	OUT3	OUT2	OUT1
Write:								
Reset:	0	0	0	0	0	0	0	0

Unimplemented

Figure 12-22. PWM Output Control Register (PWMOUT)

If the OUTCTL bit is set, the PWM pins can be controlled by the OUTx bits. These bits behave according to [Table 12-6](#).

Table 12-6. OUTx Bits

OUTx Bit	Complementary Mode	Independent Mode
OUT1	1 — PWM1 is active. 0 — PWM1 is inactive.	1 — PWM1 is active. 0 — PWM1 is inactive.
OUT2	1 — PWM2 is complement of PWM 1. 0 — PWM2 is inactive.	1 — PWM2 is active. 0 — PWM2 is inactive.
OUT3	1 — PWM3 is active. 0 — PWM3 is inactive.	1 — PWM3 is active. 0 — PWM3 is inactive.
OUT4	1 — PWM4 is complement of PWM 3. 0 — PWM4 is inactive.	1 — PWM4 is active. 0 — PWM4 is inactive.
OUT5	1 — PWM5 is active. 0 — PWM5 is inactive.	1 — PWM5 is active. 0 — PWM5 is inactive.
OUT6	1 — PWM 6 is complement of PWM 5. 0 — PWM6 is inactive.	1 — PWM6 is active. 0 — PWM6 is inactive.

When OUTCTL is set, the polarity options TOPPOL and BOTPOL will still affect the outputs. In addition, if complementary operation is in use, the PWM pairs will not be allowed to be active simultaneously, and dead-time will still not be violated. When OUTCTL is set and complementary operation is in use, the odd OUTx bits are inputs to the dead-time generators as shown in [Figure 12-15](#). Dead-time is inserted whenever the odd OUTx bit toggles as shown in [Figure 12-23](#). Although dead-time is not inserted when the even OUTx bits change, there will be no dead-time violation as shown in [Figure 12-24](#).

Setting the OUTCTL bit does not disable the PWM generator and current sensing circuitry. They continue to run, but are no longer controlling the output pins. In addition, OUTCTL will control the PWM pins even when PWMEN = 0. When OUTCTL is cleared, the outputs of the PWM generator become the inputs to the dead-time and output circuitry at the beginning of the next PWM cycle.

NOTE: *To avoid an unexpected dead-time occurrence, it is recommended that the OUTx bits be cleared prior to entering and prior to exiting individual PWM output control mode.*

Pulse-Width Modulator for Motor Control (PWMMC)

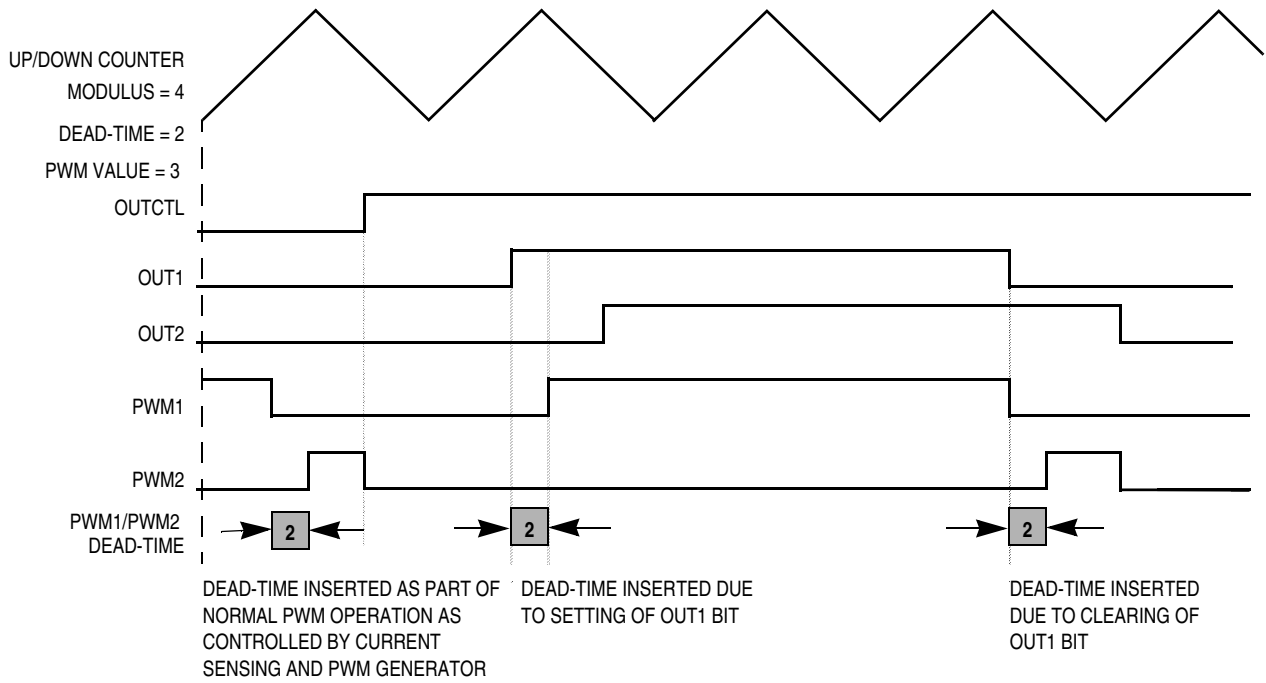

Figure 12-23. Dead-Time Insertion During OUTCTL = 1

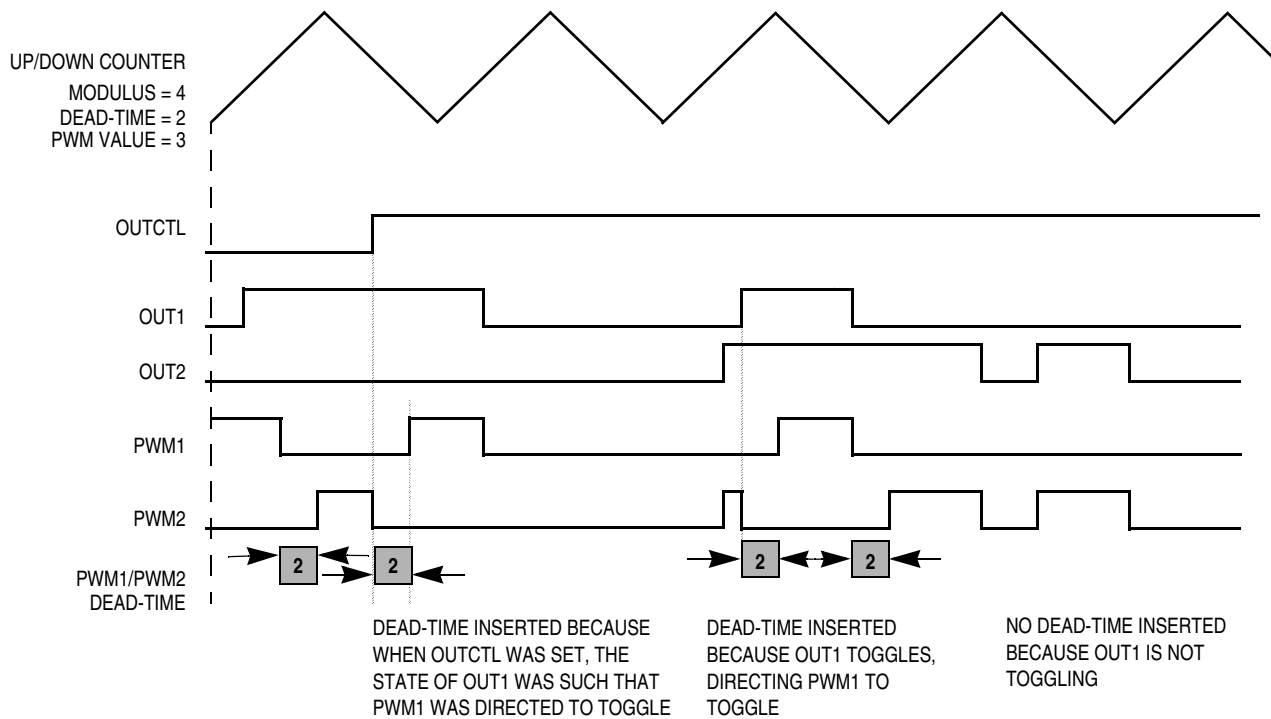

Figure 12-24. Dead-Time Insertion During OUTCTL = 1

12.6 Fault Protection

Conditions may arise in the external drive circuitry which require that the PWM signals become inactive immediately, such as an overcurrent fault condition. Furthermore, it may be desirable to selectively disable PWM(s) solely with software.

One or more PWM pins can be disabled (forced to their inactive state) by applying a logic high to any of the four external fault pins or by writing a logic high to either of the disable bits (DISX and DISY in PWM control register 1). **Figure 12-26** shows the structure of the PWM disabling scheme. While the PWM pins are disabled, they are forced to their inactive state. The PWM generator continues to run — only the output pins are disabled.

To allow for different motor configurations and the controlling of more than one motor, the PWM disabling function is organized as two banks, bank X and bank Y. Bank information combines with information from the disable mapping register to allow selective PWM disabling. Fault pin 1, fault pin 2, and PWM disable bit X constitute the disabling function of bank X. Fault pin 3, fault pin 4, and PWM disable bit Y constitute the disabling function of bank Y. **Figure 12-25** and **Figure 12-27** show the disable mapping write-once register and the decoding scheme of the bank which selectively disables PWM(s). When all bits of the disable mapping register are set, any disable condition will disable all PWMs.

A fault can also generate a CPU interrupt. Each fault pin has its own interrupt vector.

Address: \$0037

	Bit 7	6	5	4	3	2	1	Bit 0
Read:	Bit 7	Bit 6	Bit 5	Bit 4	Bit 3	Bit 2	Bit 1	Bit 0
Write:	Bit 7	Bit 6	Bit 5	Bit 4	Bit 3	Bit 2	Bit 1	Bit 0
Reset:	1	1	1	1	1	1	1	1

Figure 12-25. PWM Disable Mapping Write-Once Register (DISMAP)

12.6.1 Fault Condition Input Pins

A logic high level on a fault pin disables the respective PWM(s) determined by the bank and the disable mapping register. Each fault pin incorporates a filter to assist in rejecting spurious faults. All of the external fault pins are software-configurable to re-enable the PWMs either with the fault pin (automatic mode) or with software (manual mode). Each fault pin has an associated FMODE bit to control the PWM re-enabling method. Automatic mode is selected by setting the FMODEx bit in the fault control register. Manual mode is selected when FMODEx is clear.

Pulse-Width Modulator for Motor Control (PWMMC)

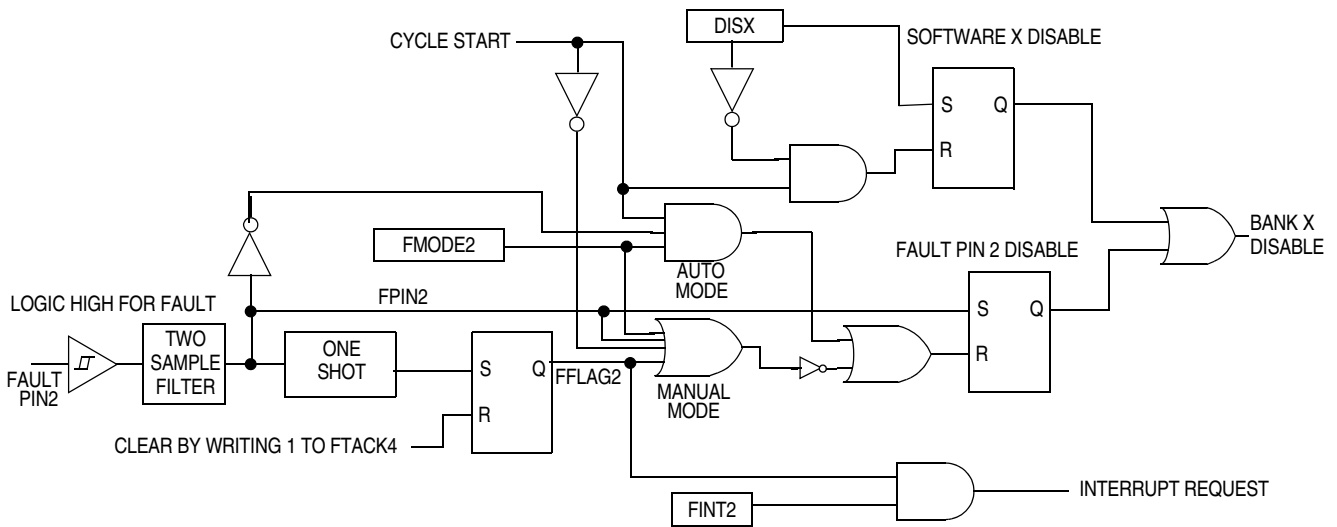

The example is of fault pin 2 with DISX. Fault pin 4 with DISY is logically similar and affects BANK Y disable.

Note: In manual mode (FMODE = 0), faults 2 and 4 may be cleared only if a logic level low at the input of the fault pin is present.

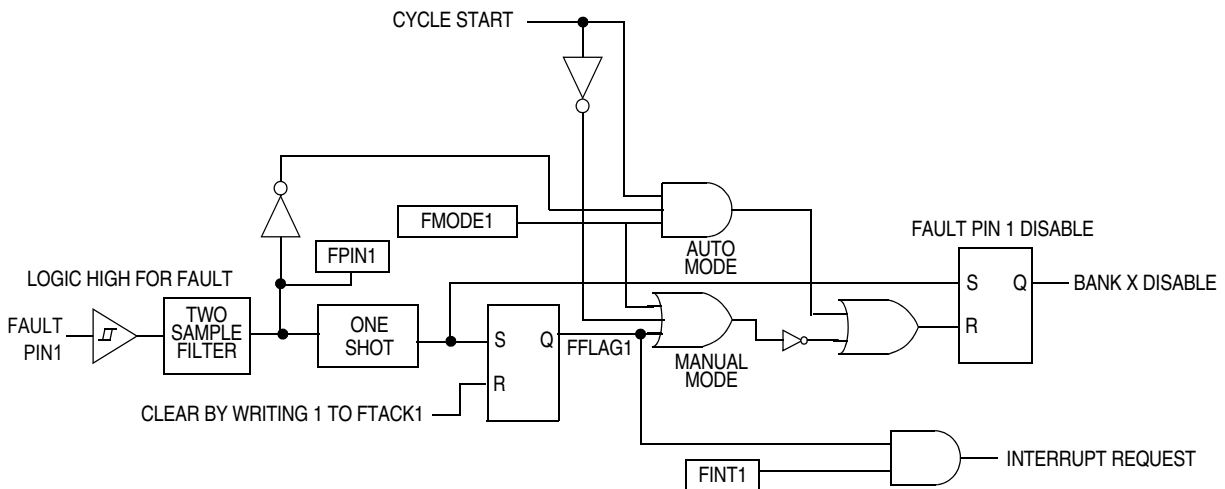

The example is of fault pin 1. Fault pin 3 is logically similar and affects BANK Y disable.

Note: In manual mode (FMODE = 0), faults 1 and 3 may be cleared regardless of the logic level at the input of the fault pin.

Figure 12-26. PWM Disabling Scheme

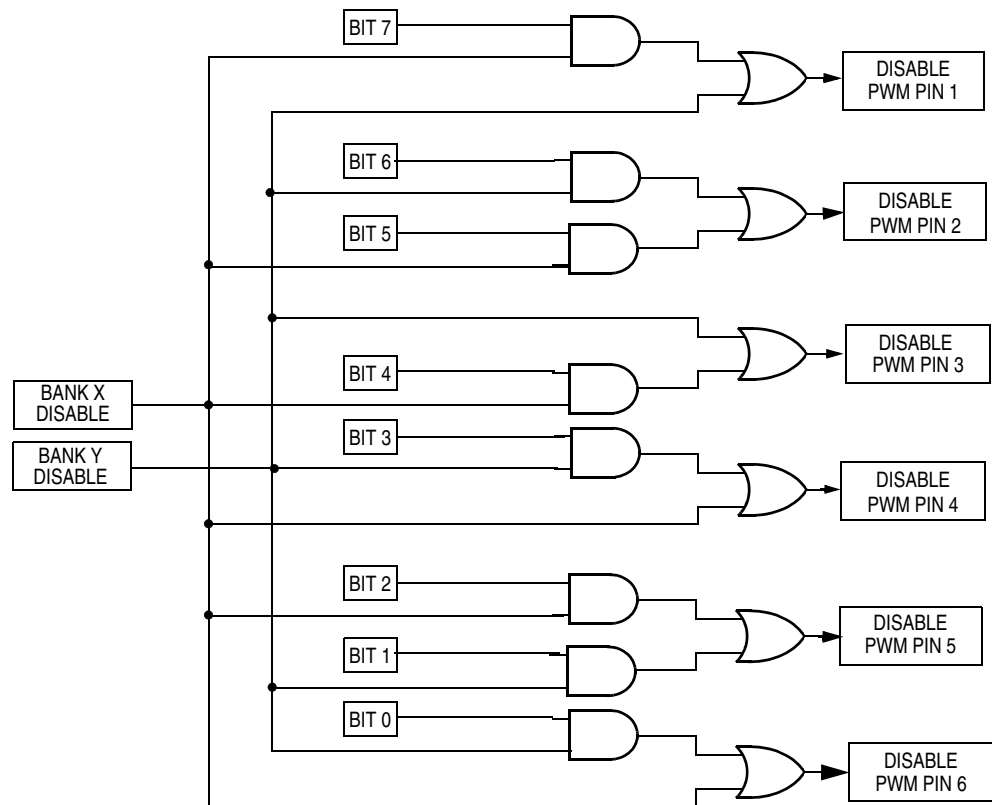

Figure 12-27. PWM Disabling Decode Scheme

12.6.1.1 Fault Pin Filter

Each fault pin incorporates a filter to assist in determining a genuine fault condition. After a fault pin has been logic low for one CPU cycle, a rising edge (logic high) will be synchronously sampled once per CPU cycle for two cycles. If both samples are detected logic high, the corresponding FPIN bit and FFLAG bit will be set. The FPIN bit will remain set until the corresponding fault pin is logic low and synchronously sampled once in the following CPU cycle.

12.6.1.2 Automatic Mode

In automatic mode, the PWM(s) are disabled immediately once a filtered fault condition is detected (logic high). The PWM(s) remain disabled until the filtered fault condition is cleared (logic low) and a new PWM cycle begins as shown in **Figure 12-28**. Clearing the corresponding FFLAGx event bit will not enable the PWMs in automatic mode.

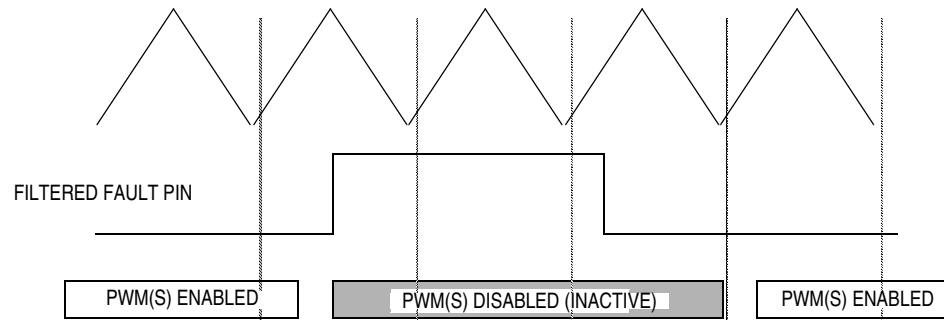

Figure 12-28. PWM Disabling in Automatic Mode

The filtered fault pin's logic state is reflected in the respective FPINx bit. Any write to this bit is overwritten by the pin state. The FFLAGx event bit is set with each rising edge of the respective fault pin after filtering has been applied. To clear the FFLAGx bit, the user must write a 1 to the corresponding FTACKx bit.

If the FINTx bit is set, a fault condition resulting in setting the corresponding FFLAG bit will also latch a CPU interrupt request. The interrupt request latch is not cleared until one of these actions occurs:

- The FFLAGx bit is cleared by writing a 1 to the corresponding FTACKx bit.
- The FINTx bit is cleared. This will not clear the FFLAGx bit.
- A reset automatically clears all four interrupt latches.

If prior to a vector fetch, the interrupt request latch is cleared by one of the actions listed, a CPU interrupt will no longer be requested. A vector fetch does not alter the state of the PWMs, the FFLAGx event flag, or FINTx.

NOTE: *If the FFLAGx or FINTx bits are not cleared during the interrupt service routine, the interrupt request latch will not be cleared.*

12.6.1.3 Manual Mode

In manual mode, the PWM(s) are disabled immediately once a filtered fault condition is detected (logic high). The PWM(s) remain disabled until software clears the corresponding FFLAGx event bit and a new PWM cycle begins. In manual mode, the fault pins are grouped in pairs, each pair sharing common functionality. A fault condition on pins 1 and 3 may be cleared, allowing the PWM(s) to enable at the start of a PWM cycle regardless of the logic level at the fault pin. See [Figure 12-29](#). A fault condition on pins 2 and 4 can only be cleared, allowing the PWM(s) to enable, if a logic low level at the fault pin is present at the start of a PWM cycle. See [Figure 12-30](#).

The function of the fault control and event bits is the same as in automatic mode except that the PWMs are not re-enabled until the FFLAGx event bit is cleared by writing to the FTACKx bit and the filtered fault condition is cleared (logic low).

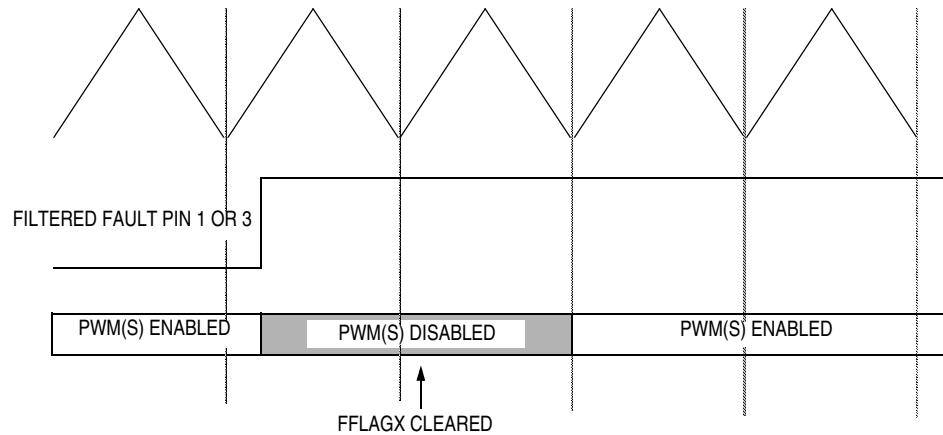

Figure 12-29. PWM Disabling in Manual Mode (Example 1)

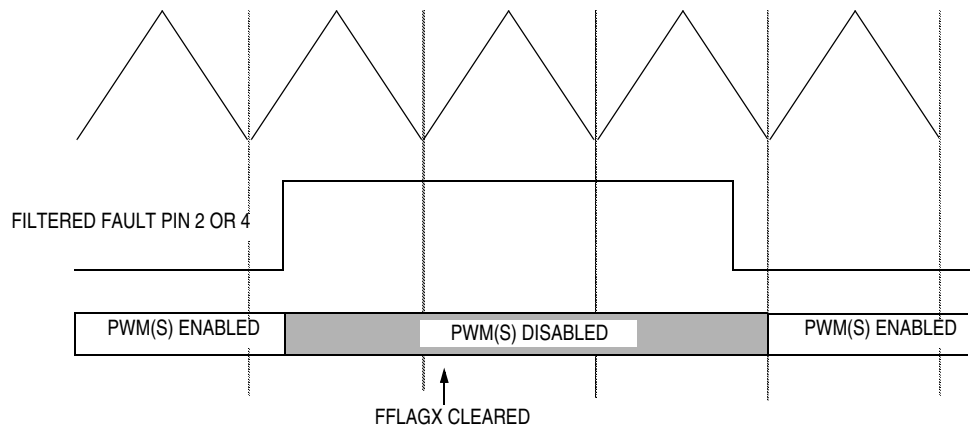

Figure 12-30. PWM Disabling in Manual Mode (Example 2)

12.6.2 Software Output Disable

Setting PWM disable bit DISX or DISY in PWM control register 1 immediately disables the corresponding PWM pins as determined by the bank and disable mapping register. The PWM pin(s) remain disabled until the PWM disable bit is cleared and a new PWM cycle begins as shown in [Figure 12-31](#). Setting a PWM disable bit does not latch a CPU interrupt request, and there are no event flags associated with the PWM disable bits.

12.6.3 Output Port Control

When operating the PWMs using the OUTx bits (OUTCTL = 1), fault protection applies as described in this section. Due to the absence of periodic PWM cycles, fault conditions are cleared upon each CPU cycle and the PWM outputs are re-enabled, provided all fault clearing conditions are satisfied.

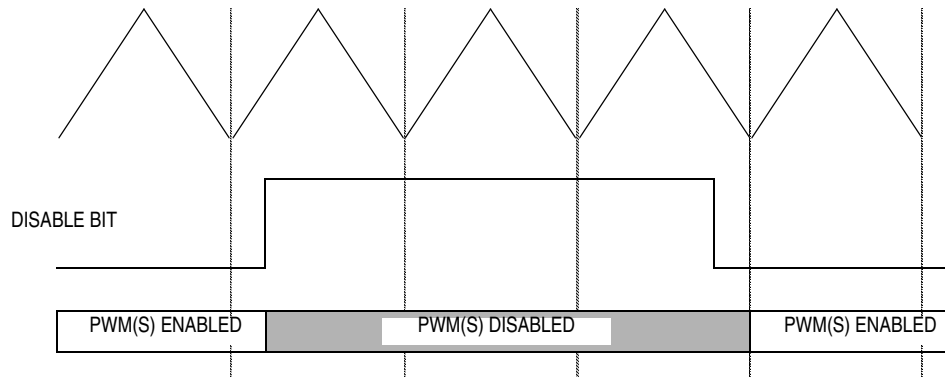

Figure 12-31. PWM Software Disable

12.7 Initialization and the PWMEN Bit

For proper operation, all registers should be initialized and the LDOK bit should be set before enabling the PWM via the PWMEN bit. When the PWMEN bit is first set, a reload will occur immediately, setting the PWMF flag and generating an interrupt if PWMINT is set. In addition, in complementary mode, PWM value registers 1, 3, and 5 will be used for the first PWM cycle if current sensing is selected.

NOTE: *If the LDOK bit is not set when PWMEN is set after a \overline{RESET} , the prescaler and PWM values will be 0, but the modulus will be unknown. If the LDOK bit is not set after the PWMEN bit has been cleared then set (without a \overline{RESET}), the modulus value that was last loaded will be used.*

If the dead-time register (DEADTM) is changed after PWMEN or OUTCTL is set, an improper dead-time insertion could occur. However, the dead-time can never be shorter than the specified value.

Because of the equals-comparator architecture of this PWM, the modulus = 0 case is considered illegal. Therefore, the modulus register is not reset, and a modulus value of 0 will result in waveforms inconsistent with the other modulus waveforms. See [12.9.2 PWM Counter Modulo Registers](#).

When PWMEN is set, the PWM pins change from high impedance to outputs. At this time, assuming no fault condition is present, the PWM pins will drive according to the PWM values, polarity, and dead-time. See the timing diagram in [Figure 12-32](#).

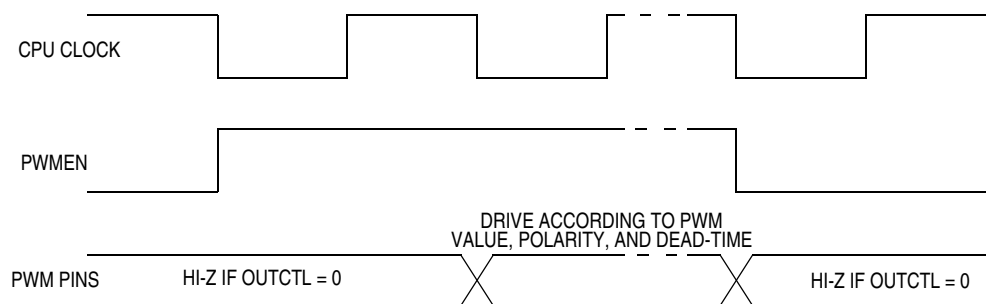

Figure 12-32. PWMEN and PWM Pins

When the PWMEN bit is cleared, this will occur:

- PWM pins will be three-stated unless $OUTCTL = 1$.
- PWM counter is cleared and will not be clocked.
- Internally, the PWM generator will force its outputs to 0 to avoid glitches when the PWMEN is set again.

When PWMEN is cleared, these features remain active:

- All fault circuitry
- Manual PWM pin control via the PWMOUT register
- Dead-time insertion when PWM pins change via the PWMOUT register

NOTE: The *PWMF* flag and pending CPU interrupts are NOT cleared when $PWMEN = 0$.

12.8 PWM Operation in Wait Mode

When the microcontroller is put in low-power wait mode via the WAIT instruction, all clocks to the PWM module will continue to run. If an interrupt is issued from the PWM module (via a reload or a fault), the microcontroller will exit wait mode.

Clearing the PWMEN bit before entering wait mode will reduce power consumption in wait mode because the counter, prescaler divider, and LDFQ divider will no longer be clocked. In addition, power will be reduced because the PWMs will no longer toggle.

12.9 Control Logic Block

This subsection provides a description of the control logic block.

12.9.1 PWM Counter Registers

The PWM counter registers (PCNTH and PCNTL) display the 12-bit up/down or up-only counter. When the high byte of the counter is read, the lower byte is latched. PCNTL will hold this latched value until it is read. See [Figure 12-33](#) and [Figure 12-34](#).

Address: \$0026

	Bit 7	6	5	4	3	2	1	Bit 0
Read:	0	0	0	0	Bit 11	Bit 10	Bit 9	Bit 8
Write:								
Reset:	0	0	0	0	0	0	0	0

= Unimplemented

Figure 12-33. PWM Counter Register High (PCNTH)

Address: \$0027

	Bit 7	6	5	4	3	2	1	Bit 0
Read:	Bit 7	Bit 6	Bit 5	Bit 4	Bit 3	Bit 2	Bit 1	Bit 0
Write:								
Reset:	0	0	0	0	0	0	0	0

= Unimplemented

Figure 12-34. PWM Counter Register Low (PCNTL)

12.9.2 PWM Counter Modulo Registers

The PWM counter modulus registers (PMODH and PMODL) hold a 12-bit unsigned number that determines the maximum count for the up/down or up-only counter. In center-aligned mode, the PWM period will be twice the modulus (assuming no prescaler). In edge-aligned mode, the PWM period will equal the modulus. See [Figure 12-35](#) and [Figure 12-36](#).

Address: \$0028

	Bit 7	6	5	4	3	2	1	Bit 0
Read:	0	0	0	0	Bit 11	Bit 10	Bit 9	Bit 8
Write:								
Reset:	0	0	0	0	X	X	X	X

= Unimplemented X = Indeterminate

Figure 12-35. PWM Counter Modulo Register High (PMODH)

Address: \$0029

	Bit 7	6	5	4	3	2	1	Bit 0
Read:	Bit 7	Bit 6	Bit 5	Bit 4	Bit 3	Bit 2	Bit 1	Bit 0
Write:								
Reset:	X	X	X	X	X	X	X	X

X = Indeterminate

Figure 12-36. PWM Counter Modulo Register Low (PMODL)

To avoid erroneous PWM periods, this value is buffered and will not be used by the PWM generator until the LDOK bit has been set and the next PWM load cycle begins.

NOTE: When reading this register, the value read is the buffer (not necessarily the value the PWM generator is currently using).

Because of the equals-comparator architecture of this PWM, the modulus = 0 case is considered illegal. Therefore, the modulus register is not reset, and a modulus value of 0 will result in waveforms inconsistent with the other modulus waveforms. If a modulus of 0 is loaded, the counter will continually count down from \$FFF. This operation will not be tested or guaranteed (the user should consider it illegal). However, the dead-time constraints and fault conditions will still be guaranteed.

12.9.3 PWMx Value Registers

Each of the six PWMs has a 16-bit PWM value register.

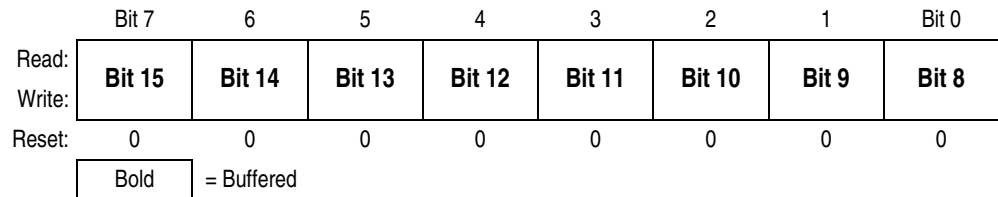

Figure 12-37. PWMx Value Registers High (PVALxH)

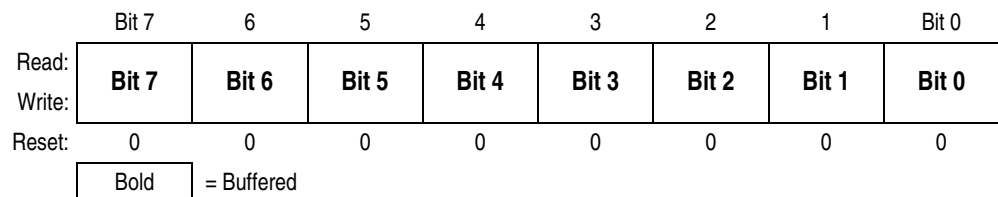

Figure 12-38. PWMx Value Registers Low (PVALxL)

The 16-bit signed value stored in this register determines the duty cycle of the PWM. The duty cycle is defined as: (PWM value/modulus) x 100.

Writing a number less than or equal to 0 causes the PWM to be off for the entire PWM period. Writing a number greater than or equal to the 12-bit modulus causes the PWM to be on for the entire PWM period.

If the complementary mode is selected, the PWM pairs share PWM value registers.

To avoid erroneous PWM pulses, this value is buffered and will not be used by the PWM generator until the LDOK bit has been set and the next PWM load cycle begins.

NOTE: When reading these registers, the value read is the buffer (not necessarily the value the PWM generator is currently using).

12.9.4 PWM Control Register 1

PWM control register 1 (PCTL1) controls PWM enabling/disabling, the loading of new modulus, prescaler, PWM values, and the PWM correction method. In addition, this register contains the software disable bits to force the PWM outputs to their inactive states (according to the disable mapping register).

Address:	\$0020							
	Bit 7	6	5	4	3	2	1	Bit 0
Read:	DISX	DISY	PWMINT	PWMF	ISENS1	ISENS0	LDOK	PWMEN
Write:								
Reset:	0	0	0	0	0	0	0	0

Figure 12-39. PWM Control Register 1 (PCTL1)

DISX — Software Disable Bit for Bank X Bit

This read/write bit allows the user to disable one or more PWM pins in bank X. The pins that are disabled are determined by the disable mapping write-once register.

- 1 = Disable PWM pins in bank X.
- 0 = Re-enable PWM pins at beginning of next PWM cycle.

DISY — Software Disable Bit for Bank Y Bit

This read/write bit allows the user to disable one or more PWM pins in bank Y. The pins that are disabled are determined by the disable mapping write-once register.

- 1 = Disable PWM pins in bank Y.
- 0 = Re-enable PWM pins at beginning of next PWM cycle.

PWMINT — PWM Interrupt Enable Bit

This read/write bit allows the user to enable and disable PWM CPU interrupts. If set, a CPU interrupt will be pending when the PWMF flag is set.

- 1 = Enable PWM CPU interrupts.
- 0 = Disable PWM CPU interrupts.

NOTE: When PWMINT is cleared, pending CPU interrupts are inhibited.

PWMF — PWM Reload Flag

This read/write bit is set at the beginning of every reload cycle regardless of the state of the LDOK bit. This bit is cleared by reading PWM control register 1 with the PWMF flag set, then writing a logic 0 to PWMF. If another reload occurs before the clearing sequence is complete, then writing logic 0 to PWMF has no effect.

- 1 = New reload cycle began.
- 0 = New reload cycle has not begun.

NOTE: When PWMF is cleared, pending PWM CPU interrupts are cleared (not including fault interrupts).

ISENS1 and ISENS0 — Current Sense Correction Bits

These read/write bits select the top/bottom correction scheme as shown in [Table 12-7](#).

Table 12-7. Correction Methods

Current Correction Bits ISENS1 and ISENS0	Correction Method
00 01	Bits IPOL1, IPOL2, and IPOL3 are used for correction.
10	Current sensing on pins $\overline{IS1}$, $\overline{IS2}$, and $\overline{IS3}$ occurs during the dead-time.
11	Current sensing on pins $\overline{IS1}$, $\overline{IS2}$, and $\overline{IS3}$ occurs at the half cycle in center-aligned mode and at the end of the cycle in edge-aligned mode.

1. The polarity of the \overline{ISx} pin is latched when both the top and bottom PWMs are off. At the 0% and 100% duty cycle boundaries, there is no dead-time, so no new current value is sensed.
2. Current is sensed even with 0% and 100% duty cycle.

NOTE: *The ISENSx bits are not buffered. Changing the current sensing method can affect the present PWM cycle.*

LDOK— Load OK Bit

This read/write bit loads the prescaler bits of the PMCTL2 register and the entire PMMODH/L and PWMVALH/L registers into a set of buffers. The buffered prescaler divisor, PWM counter modulus value, and PWM pulse will take effect at the next PWM load. Set LDOK by reading it when it is logic 0 and then writing a logic 1 to it. LDOK is automatically cleared after the new values are loaded or can be manually cleared before a reload by writing a 0 to it. Reset clears LDOK.

1 = Load prescaler, modulus, and PWM values.

0 = Do not load new modulus, prescaler, and PWM values.

NOTE: *The user should initialize the PWM registers and set the LDOK bit before enabling the PWM.*

A PWM CPU interrupt request can still be generated when LDOK is 0.

PWMEN — PWM Module Enable Bit

This read/write bit enables and disables the PWM generator and the PWM pins. When PWMEN is clear, the PWM generator is disabled and the PWM pins are in the high-impedance state (unless OUTCTL = 1).

When the PWMEN bit is set, the PWM generator and PWM pins are activated. For more information, see [12.7 Initialization and the PWMEN Bit](#).

1 = PWM generator and PWM pins enabled

0 = PWM generator and PWM pins disabled

12.9.5 PWM Control Register 2

PWM control register 2 (PCTL2) controls the PWM load frequency, the PWM correction method, and the PWM counter prescaler. For ease of software and to avoid erroneous PWM periods, some of these register bits are buffered. The PWM generator will not use the prescaler value until the LDOK bit has been set, and a new PWM cycle is starting. The correction bits are used at the beginning of each PWM cycle (if the ISENSx bits are configured for software correction). The load frequency bits are not used until the current load cycle is complete.

See [Figure 12-40](#).

NOTE: The user should initialize this register before enabling the PWM.

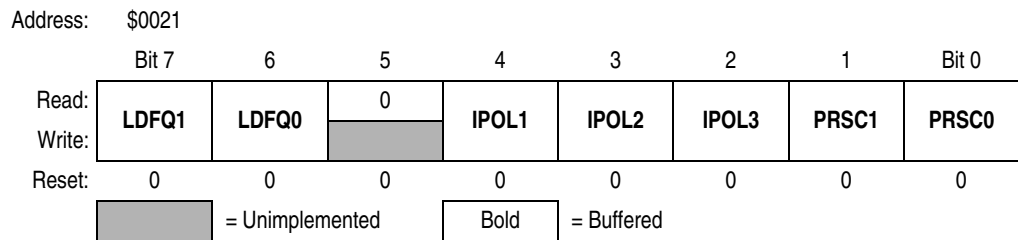

Figure 12-40. PWM Control Register 2 (PCTL2)

LDFQ1 and LDFQ0 — PWM Load Frequency Bits

These buffered read/write bits select the PWM CPU load frequency according to [Table 12-8](#).

NOTE: When reading these bits, the value read is the buffer value (not necessarily the value the PWM generator is currently using).

The LDFQx bits take effect when the current load cycle is complete regardless of the state of the load okay bit, LDOK.

Table 12-8. PWM Reload Frequency

Reload Frequency Bits LDFQ1 and LDFQ0	PWM Reload Frequency
00	Every PWM cycle
01	Every 2 PWM cycles
10	Every 4 PWM cycles
11	Every 8 PWM cycles

NOTE: Reading the LPFQx bit reads the buffered values and not necessarily the values currently in effect.

IPOL1 — Top/Bottom Correction Bit for PWM Pair 1 (PWMs 1 and 2)
This buffered read/write bit selects which PWM value register is used if top/bottom correction is to be achieved without current sensing.

1 = Use PWM value register 2.

0 = Use PWM value register 1.

NOTE: When reading this bit, the value read is the buffer value (not necessarily the value the output control block is currently using).

The *IPOLx* bits take effect at the beginning of the next load cycle, regardless of the state of the load okay bit, *LDOK*.

IPOL2 — Top/Bottom Correction Bit for PWM Pair 2 (PWMs 3 and 4)

This buffered read/write bit selects which PWM value register is used if top/bottom correction is to be achieved without current sensing.

1 = Use PWM value register 4.

0 = Use PWM value register 3.

NOTE: When reading this bit, the value read is the buffer value (not necessarily the value the output control block is currently using).

IPOL3 — Top/Bottom Correction Bit for PWM Pair 3 (PWMs 5 and 6)

This buffered read/write bit selects which PWM value register is used if top/bottom correction is to be achieved without current sensing.

1 = Use PWM value register 6.

0 = Use PWM value register 5.

NOTE: When reading this bit, the value read is the buffer value (not necessarily the value the output control block is currently using).

PRSC1 and PRSC0 — PWM Prescaler Bits

These buffered read/write bits allow the PWM clock frequency to be modified as shown in [Table 12-9](#).

NOTE: When reading these bits, the value read is the buffer value (not necessarily the value the PWM generator is currently using).

Table 12-9. PWM Prescaler

Prescaler Bits PRSC1 and PRSC0	PWM Clock Frequency
00	f_{OP}
01	$f_{OP}/2$
10	$f_{OP}/4$
11	$f_{OP}/8$

12.9.6 Dead-Time Write-Once Register

The dead-time write-once register (DEADTM) holds an 8-bit value which specifies the number of CPU clock cycles to use for the dead-time when complementary PWM mode is selected. After this register is written for the first time, it cannot be rewritten unless a reset occurs. Dead-time is not affected by changes to the prescaler value.

Address:	\$0036							
	Bit 7	6	5	4	3	2	1	Bit 0
Read:	Bit 7	Bit 6	Bit 5	Bit 4	Bit 3	Bit 2	Bit 1	Bit 0
Write:	Bit 7	Bit 6	Bit 5	Bit 4	Bit 3	Bit 2	Bit 1	Bit 0
Reset:	1	1	1	1	1	1	1	1

Figure 12-41. Dead-Time Write-Once Register (DEADTM)

12.9.7 PWM Disable Mapping Write-Once Register

The PWM disable mapping write-once register (DISMAP) holds an 8-bit value which determines which PWM pins will be disabled if an external fault or software disable occurs. For a further description of disable mapping, see [12.6 Fault Protection](#). After this register is written for the first time, it cannot be rewritten unless a reset occurs.

Address:	\$0037							
	Bit 7	6	5	4	3	2	1	Bit 0
Read:	Bit 7	Bit 6	Bit 5	Bit 4	Bit 3	Bit 2	Bit 1	Bit 0
Write:	Bit 7	Bit 6	Bit 5	Bit 4	Bit 3	Bit 2	Bit 1	Bit 0
Reset:	1	1	1	1	1	1	1	1

Figure 12-42. PWM Disable Mapping Write-Once Register (DISMAP)

12.9.8 Fault Control Register

The fault control register (FCR) controls the fault-protection circuitry.

Address:	\$0022							
	Bit 7	6	5	4	3	2	1	Bit 0
Read:	FINT4	FMODE4	FINT3	FMODE3	FINT2	FMODE2	FINT1	FMODE1
Write:	FINT4	FMODE4	FINT3	FMODE3	FINT2	FMODE2	FINT1	FMODE1
Reset:	0	0	0	0	0	0	0	0

Figure 12-43. Fault Control Register (FCR)

FINT4 — Fault 4 Interrupt Enable Bit

This read/write bit allows the CPU interrupt caused by faults on fault pin 4 to be enabled. The fault protection circuitry is independent of this bit and will always be active. If a fault is detected, the PWM pins will still be disabled according to the disable mapping register.

1 = Fault pin 4 will cause CPU interrupts.

0 = Fault pin 4 will not cause CPU interrupts.

FMODE4 — Fault Mode Selection for Fault Pin 4 Bit (automatic versus manual mode)

This read/write bit allows the user to select between automatic and manual mode faults. For further descriptions of each mode, see [12.6 Fault Protection](#).

1 = Automatic mode

0 = Manual mode

FINT3 — Fault 3 Interrupt Enable Bit

This read/write bit allows the CPU interrupt caused by faults on fault pin 3 to be enabled. The fault protection circuitry is independent of this bit and will always be active. If a fault is detected, the PWM pins will still be disabled according to the disable mapping register.

1 = Fault pin 3 will cause CPU interrupts.

0 = Fault pin 3 will not cause CPU interrupts.

FMODE3 — Fault Mode Selection for Fault Pin 3 Bit (automatic versus manual mode)

This read/write bit allows the user to select between automatic and manual mode faults. For further descriptions of each mode, see [12.6 Fault Protection](#).

1 = Automatic mode

0 = Manual mode

FINT2 — Fault 2 Interrupt Enable Bit

This read/write bit allows the CPU interrupt caused by faults on fault pin 2 to be enabled. The fault protection circuitry is independent of this bit and will always be active. If a fault is detected, the PWM pins will still be disabled according to the disable mapping register.

1 = Fault pin 2 will cause CPU interrupts.

0 = Fault pin 2 will not cause CPU interrupts.

FMODE2 — Fault Mode Selection for Fault Pin 2 Bit (automatic versus manual mode)

This read/write bit allows the user to select between automatic and manual mode faults. For further descriptions of each mode, see [12.6 Fault Protection](#).

1 = Automatic mode

0 = Manual mode

FINT1 — Fault 1 Interrupt Enable Bit

This read/write bit allows the CPU interrupt caused by faults on fault pin 1 to be enabled. The fault protection circuitry is independent of this bit and will always be active. If a fault is detected, the PWM pins will still be disabled according to the disable mapping register.

- 1 = Fault pin 1 will cause CPU interrupts.
- 0 = Fault pin 1 will not cause CPU interrupts.

FMODE1 — Fault Mode Selection for Fault Pin 1 Bit
(automatic versus manual mode)

This read/write bit allows the user to select between automatic and manual mode faults. For further descriptions of each mode, see [12.6 Fault Protection](#).

- 1 = Automatic mode
- 0 = Manual mode

12.9.9 Fault Status Register

The fault status register (FSR) is a read-only register that indicates the current fault status.

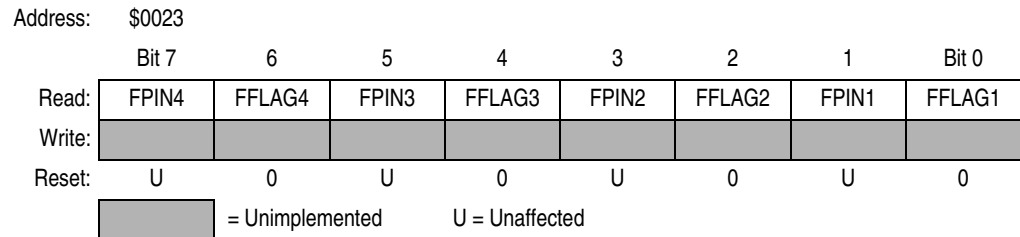

Figure 12-44. Fault Status Register (FSR)

FPIN4 — State of Fault Pin 4 Bit

This read-only bit allows the user to read the current state of fault pin 4.

- 1 = Fault pin 4 is at logic 1.
- 0 = Fault pin 4 is at logic 0.

FFLAG4 — Fault Event Flag 4

The FFLAG4 event bit is set within two CPU cycles after a rising edge on fault pin 4. To clear the FFLAG4 bit, the user must write a 1 to the FTACK4 bit in the fault acknowledge register.

- 1 = A fault has occurred on fault pin 4.
- 0 = No new fault on fault pin 4

FPIN3 — State of Fault Pin 3 Bit

This read-only bit allows the user to read the current state of fault pin 3.

- 1 = Fault pin 3 is at logic 1.
- 0 = Fault pin 3 is at logic 0.

FFLAG3 — Fault Event Flag 3

The FFLAG3 event bit is set within two CPU cycles after a rising edge on fault pin 3. To clear the FFLAG3 bit, the user must write a 1 to the FTACK3 bit in the fault acknowledge register.

1 = A fault has occurred on fault pin 3.

0 = No new fault on fault pin 3.

FPIN2 — State of Fault Pin 2 Bit

This read-only bit allows the user to read the current state of fault pin 2.

1 = Fault pin 2 is at logic 1.

0 = Fault pin 2 is at logic 0.

FFLAG2 — Fault Event Flag 2

The FFLAG2 event bit is set within two CPU cycles after a rising edge on fault pin 2. To clear the FFLAG2 bit, the user must write a 1 to the FTACK2 bit in the fault acknowledge register.

1 = A fault has occurred on fault pin 2.

0 = No new fault on fault pin 2

FPIN1 — State of Fault Pin 1 Bit

This read-only bit allows the user to read the current state of fault pin 1.

1 = Fault pin 1 is at logic 1.

0 = Fault pin 1 is at logic 0.

FFLAG1 — Fault Event Flag 1

The FFLAG1 event bit is set within two CPU cycles after a rising edge on fault pin 1. To clear the FFLAG1 bit, the user must write a 1 to the FTACK1 bit in the fault acknowledge register.

1 = A fault has occurred on fault pin 1.

0 = No new fault on fault pin 1.

12.9.10 Fault Acknowledge Register

The fault acknowledge register (FTACK) is used to acknowledge and clear the FFLAGs. In addition, it is used to monitor the current sensing bits to test proper operation.

Address: \$0024

	Bit 7	6	5	4	3	2	1	Bit 0
Read:	0	0	DT6	DT5	DT4	DT3	DT2	DT1
Write:		FTACK4		FTACK3		FTACK2		FTACK1
Reset:	0	0	0	0	0	0	0	0

 = Unimplemented

Figure 12-45. Fault Acknowledge Register (FTACK)

FTACK4 — Fault Acknowledge 4 Bit

The FTACK4 bit is used to acknowledge and clear FFLAG4. This bit will always read 0. Writing a 1 to this bit will clear FFLAG4. Writing a 0 will have no effect.

FTACK3 — Fault Acknowledge 3 Bit

The FTACK3 bit is used to acknowledge and clear FFLAG3. This bit will always read 0. Writing a 1 to this bit will clear FFLAG3. Writing a 0 will have no effect.

FTACK2 — Fault Acknowledge 2 Bit

The FTACK2 bit is used to acknowledge and clear FFLAG2. This bit will always read 0. Writing a 1 to this bit will clear FFLAG2. Writing a 0 will have no effect.

FTACK1 — Fault Acknowledge 1 Bit

The FTACK1 bit is used to acknowledge and clear FFLAG1. This bit will always read 0. Writing a 1 to this bit will clear FFLAG1. Writing a 0 will have no effect.

DT6 — Dead-Time 6 Bit

Current sensing pin IS3 is monitored immediately before dead-time ends due to the assertion of PWM6.

DT5 — Dead-Time 5 Bit

Current sensing pin IS3 is monitored immediately before dead-time ends due to the assertion of PWM5.

DT4 — Dead-Time 4 Bit

Current sensing pin IS2 is monitored immediately before dead-time ends due to the assertion of PWM4.

DT3 — Dead-Time 3 Bit

Current sensing pin IS2 is monitored immediately before dead-time ends due to the assertion of PWM3.

DT2 — Dead-Time 2 Bit

Current sensing pin IS1 is monitored immediately before dead-time ends due to the assertion of PWM2.

DT1 — Dead-Time 1 Bit

Current sensing pin IS1 is monitored immediately before dead-time ends due to the assertion of PWM1.

12.9.11 PWM Output Control Register

The PWM output control register (PWMOUT) is used to manually control the PWM pins.

Address: \$0025

	Bit 7	6	5	4	3	2	1	Bit 0
Read:	0	OUTCTL	OUT6	OUT5	OUT4	OUT3	OUT2	OUT1
Write:								
Reset:	0	0	0	0	0	0	0	0

= Unimplemented

Figure 12-46. PWM Output Control Register (PWMOUT)

OUTCTL— Output Control Enable Bit

This read/write bit allows the user to manually control the PWM pins. When set, the PWM generator is no longer the input to the dead-time and output circuitry. The OUTx bits determine the state of the PWM pins. Setting the OUTCTL bit does not disable the PWM generator. The generator continues to run, but is no longer the input to the PWM dead-time and output circuitry. When OUTCTL is cleared, the outputs of the PWM generator immediately become the inputs to the dead-time and output circuitry.

1 = PWM outputs controlled manually

0 = PWM outputs determined by PWM generator

OUT6–OUT1— PWM Pin Output Control Bits

These read/write bits control the PWM pins according to [Table 12-10](#).

Table 12-10. OUTx Bits

OUTx Bit	Complementary Mode	Independent Mode
OUT1	1 — PWM1 is active. 0 — PWM1 is inactive.	1 — PWM1 is active. 0 — PWM1 is inactive.
OUT2	1 — PWM2 is complement of PWM 1. 0 — PWM2 is inactive.	1 — PWM2 is active. 0 — PWM2 is inactive.
OUT3	1 — PWM3 is active. 0 — PWM3 is inactive.	1 — PWM3 is active. 0 — PWM3 is inactive.
OUT4	1 — PWM4 is complement of PWM 3. 0 — PWM4 is inactive.	1 — PWM4 is active. 0 — PWM4 is inactive.
OUT5	1 — PWM5 is active. 0 — PWM5 is inactive.	1 — PWM5 is active. 0 — PWM5 is inactive.
OUT6	1 — PWM 6 is complement of PWM 5. 0 — PWM6 is inactive.	1 — PWM6 is active. 0 — PWM6 is inactive.

12.10 PWM Glossary

CPU cycle — One internal bus cycle ($1/f_{OP}$)

PWM clock cycle (or period) — One tick of the PWM counter ($1/f_{OP}$ with no prescaler). See [Figure 12-47](#).

PWM cycle (or period)

- Center-aligned mode: The time it takes the PWM counter to count up and count down ($\text{modulus} * 2/f_{OP}$ assuming no prescaler). See [Figure 12-47](#).
- Edge-aligned mode: The time it takes the PWM counter to count up ($\text{modulus}/f_{OP}$). See [Figure 12-47](#).

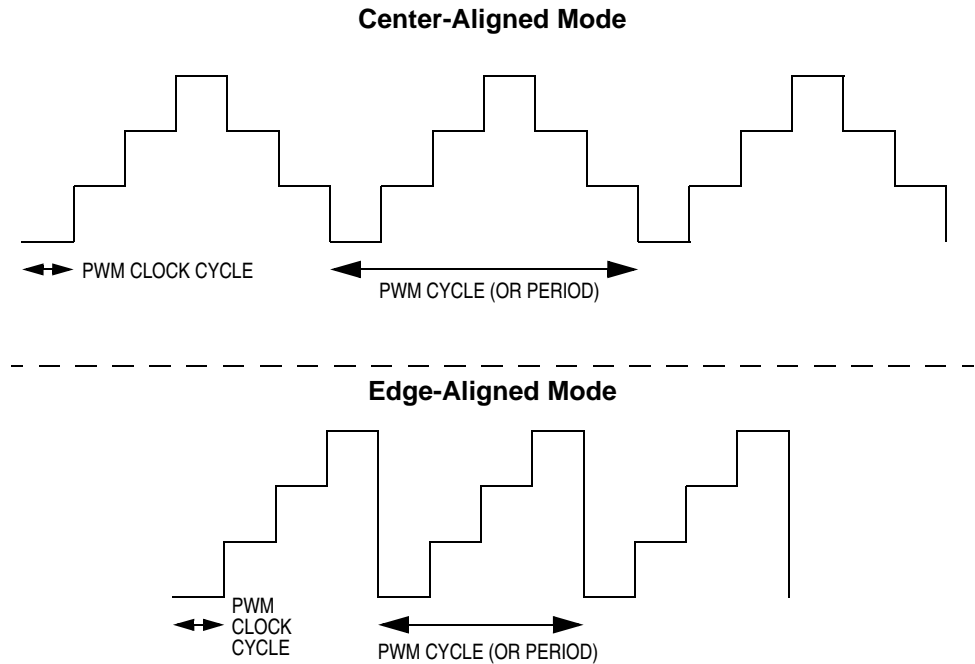

Figure 12-47. PWM Clock Cycle and PWM Cycle Definitions

PWM Load Frequency — Frequency at which new PWM parameters get loaded into the PWM. See [Figure 12-48](#).

LDFQ1:LDFQ0 = 01 — Reload Every Two Cycles

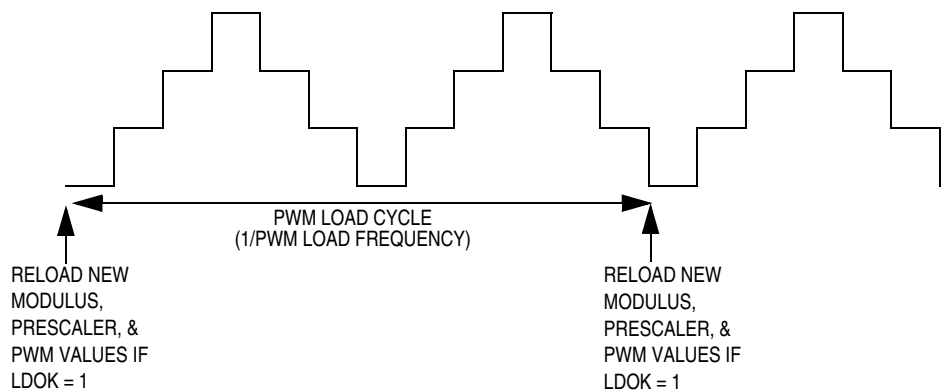

Figure 12-48. PWM Load Cycle/Frequency Definition

Section 13. Serial Communications Interface Module (SCI)

13.1 Introduction

This section describes the serial communications interface module (SCI, version D), which allows high-speed asynchronous communications with peripheral devices and other microcontroller units (MCUs).

13.2 Features

Features of the SCI module include:

- Full-duplex operation
- Standard mark/space non-return-to-zero (NRZ) format
- 32 programmable baud rates
- Programmable 8-bit or 9-bit character length
- Separately enabled transmitter and receiver
- Separate receiver and transmitter CPU interrupt requests
- Separate receiver and transmitter
- Programmable transmitter output polarity
- Two receiver wakeup methods:
 - Idle line wakeup
 - Address mark wakeup
- Interrupt-driven operation with eight interrupt flags:
 - Transmitter empty
 - Transmission complete
 - Receiver full
 - Idle receiver input
 - Receiver overrun
 - Noise error
 - Framing error
 - Parity error
- Receiver framing error detection
- Hardware parity checking
- 1/16 bit-time noise detection

Serial Communications Interface Module (SCI)

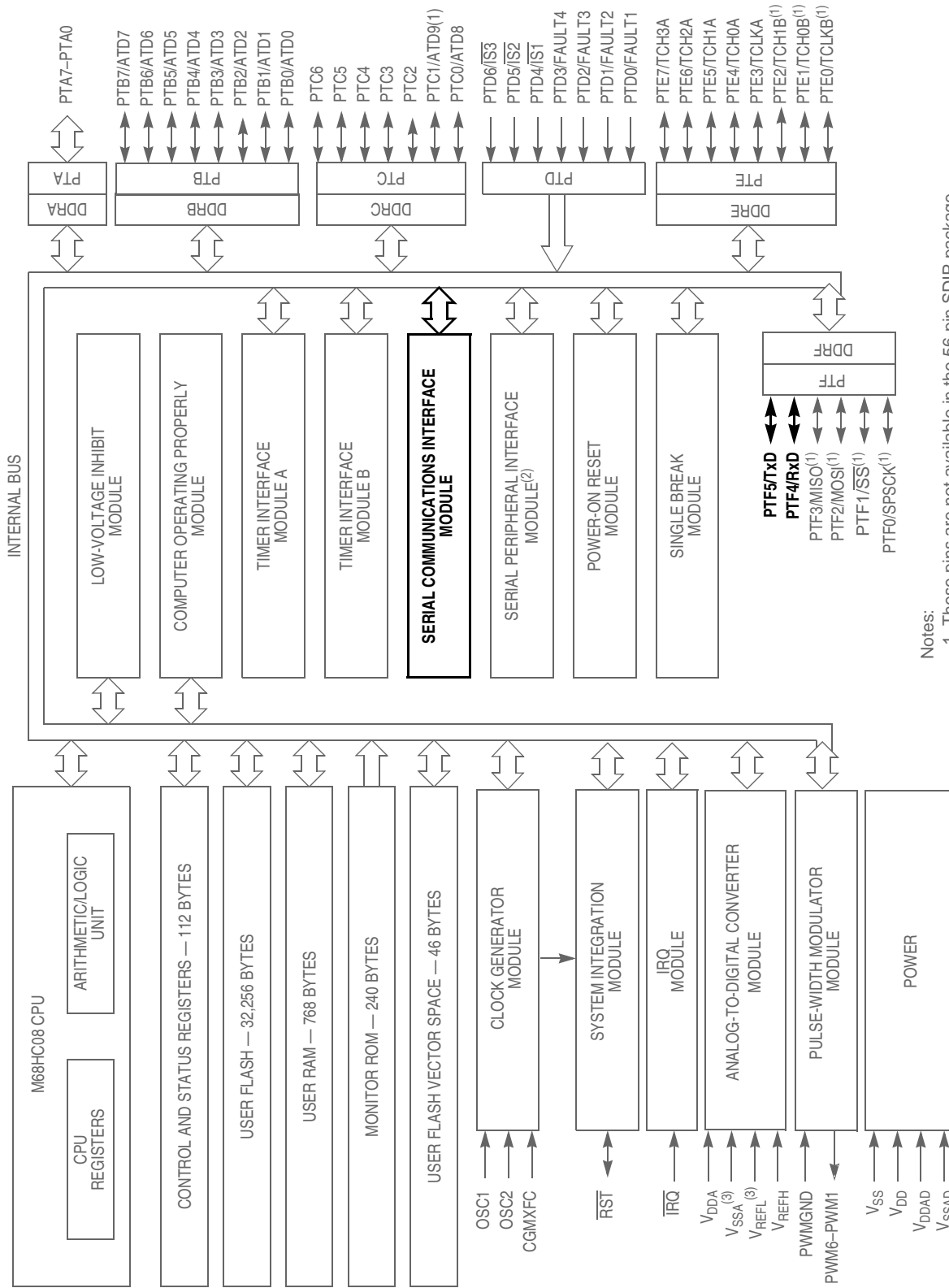

- Notes:
1. These pins are not available in the 56-pin SDIP package.
 2. This module is not available in the 56-pin SDIP package.
 3. In the 56-pin SDIP package, these pins are bonded together.

Figure 13-1. Block Diagram Highlighting SCI Block and Pins

13.3 Functional Description

Figure 13-2 shows the structure of the SCI module. The SCI allows full-duplex, asynchronous, NRZ serial communication among the MCU and remote devices, including other MCUs. The transmitter and receiver of the SCI operate independently, although they use the same baud rate generator. During normal operation, the CPU monitors the status of the SCI, writes the data to be transmitted, and processes received data.

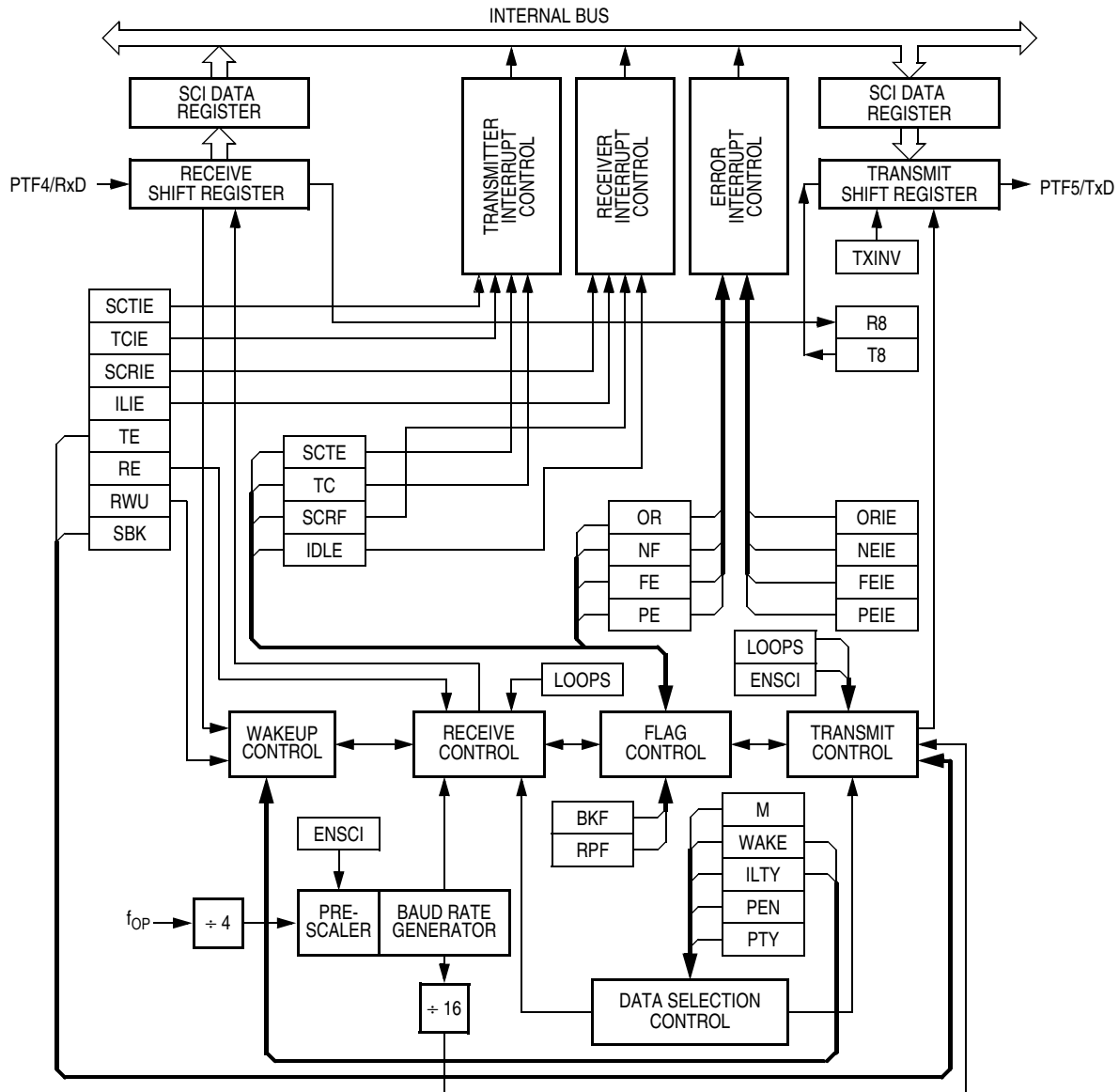

Figure 13-2. SCI Module Block Diagram

Serial Communications Interface Module (SCI)

Addr.	Register Name	Bit 7	6	5	4	3	2	1	Bit 0	
\$0038	SCI Control Register 1 (SCC1) See page 183.	Read:	LOOPS	ENSCI	TXINV	M	WAKE	ILTY	PEN	PTY
		Write:								
		Reset:	0	0	0	0	0	0	0	0
\$0039	SCI Control Register 2 (SCC2) See page 185.	Read:	SCTIE	TCIE	SCRIE	ILIE	TE	RE	RWU	SBK
		Write:								
		Reset:	0	0	0	0	0	0	0	0
\$003A	SCI Control Register 3 (SCC3) See page 187.	Read:	R8	T8	0	0	ORIE	NEIE	FEIE	PEIE
		Write:	R		R	R				
		Reset:	U	U	0	0	0	0	0	0
\$003B	SCI Status Register 1 (SCS1) See page 188.	Read:	SCTE	TC	SCRF	IDLE	OR	NF	FE	PE
		Write:	R	R	R	R	R	R	R	R
		Reset:	1	1	0	0	0	0	0	0
\$003C	SCI Status Register 2 (SCS2) See page 191.	Read:	0	0	0	0	0	0	BKF	RPF
		Write:	R	R	R	R	R	R	R	R
		Reset:	0	0	0	0	0	0	0	0
\$003D	SCI Data Register (SCDR) See page 192.	Read:	R7	R6	R5	R4	R3	R2	R1	R0
		Write:	T7	T6	T5	T4	T3	T2	T1	T0
		Reset:	Unaffected by reset							
\$003E	SCI Baud Rate Register (SCBR) See page 192.	Read:	0	0	SCP1	SCP0	0	SCR2	SCR1	SCR0
		Write:	R	R			R			
		Reset:	0	0	0	0	0	0	0	0

R = Reserved U = Unaffected

Figure 13-3. SCI I/O Register Summary

13.3.1 Data Format

The SCI uses the standard non-return-to-zero mark/space data format illustrated in [Figure 13-4](#).

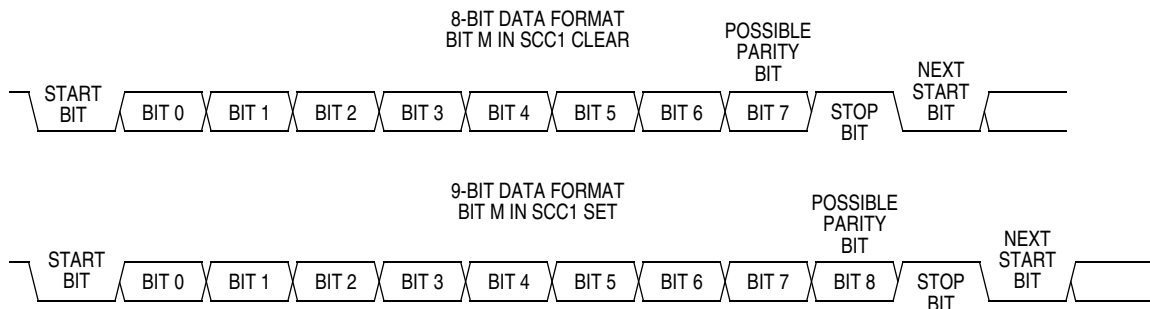

Figure 13-4. SCI Data Formats

13.3.2 Transmitter

Figure 13-5 shows the structure of the SCI transmitter.

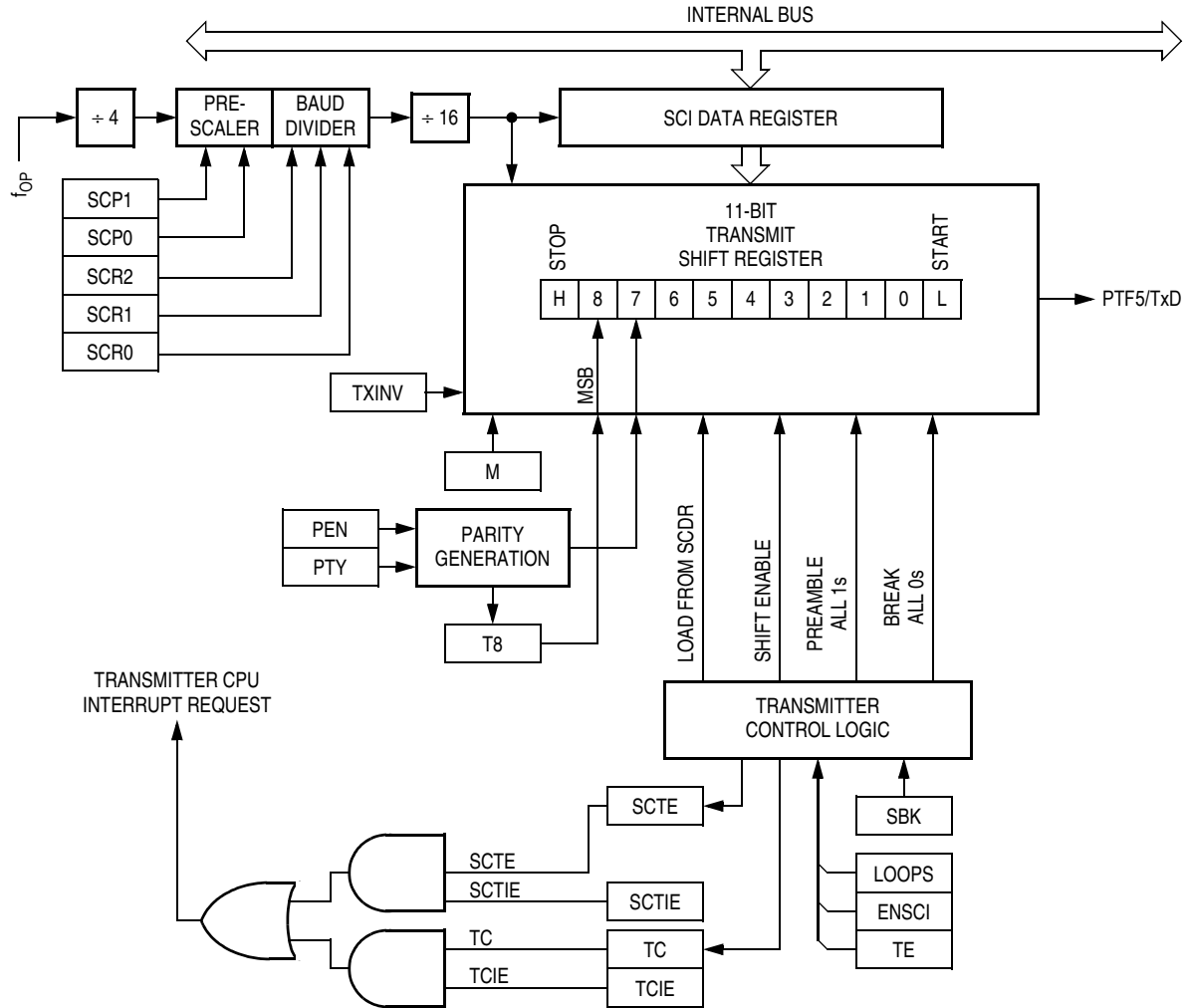

Figure 13-5. SCI Transmitter

13.3.2.1 Character Length

The transmitter can accommodate either 8-bit or 9-bit data. The state of the M bit in SCI control register 1 (SCC1) determines character length. When transmitting 9-bit data, bit T8 in SCI control register 3 (SCC3) is the ninth bit (bit 8).

13.3.2.2 Character Transmission

During an SCI transmission, the transmit shift register shifts a character out to the PTF5/TxD pin. The SCI data register (SCDR) is the write-only buffer between the internal data bus and the transmit shift register. To initiate an SCI transmission:

1. Enable the SCI by writing a 1 to the enable SCI bit (ENSCI) in SCI control register 1 (SCC1).
2. Enable the transmitter by writing a 1 to the transmitter enable bit (TE) in SCI control register 2 (SCC2).
3. Clear the SCI transmitter empty bit by first reading SCI status register 1 (SCS1) and then writing to the SCDR.
4. Repeat step 3 for each subsequent transmission.

At the start of a transmission, transmitter control logic automatically loads the transmit shift register with a preamble of 1s. After the preamble shifts out, control logic transfers the SCDR data into the transmit shift register. A 0 start bit automatically goes into the least significant bit (LSB) position of the transmit shift register. A 1 stop bit goes into the most significant bit (MSB) position.

The SCI transmitter empty bit, SCTE, in SCS1 becomes set when the SCDR transfers a byte to the transmit shift register. The SCTE bit indicates that the SCDR can accept new data from the internal data bus. If the SCI transmit interrupt enable bit, SCTIE, in SCC2 is also set, the SCTE bit generates a transmitter CPU interrupt request.

When the transmit shift register is not transmitting a character, the PTF5/TxD pin goes to the idle condition, logic 1. If at any time software clears the ENSCI bit in SCI control register 1 (SCC1), the transmitter and receiver relinquish control of the port E pins.

13.3.2.3 Break Characters

Writing a 1 to the send break bit, SBK, in SCC2 loads the transmit shift register with a break character. A break character contains all 0s and has no start, stop, or parity bit. Break character length depends on the M bit in SCC1. As long as SBK is at 1, transmitter logic continuously loads break characters into the transmit shift register. After software clears the SBK bit, the shift register finishes transmitting the last break character and then transmits at least one logic 1. The automatic logic 1 at the end of a break character guarantees the recognition of the start bit of the next character.

The SCI recognizes a break character when a start bit is followed by eight or nine logic 0 data bits and a logic 0 where the stop bit should be.

Receiving a break character has these effects on SCI registers:

- Sets the framing error bit (FE) in SCS1
- Sets the SCI receiver full bit (SCRF) in SCS1
- Clears the SCI data register (SCDR)
- Clears the R8 bit in SCC3
- Sets the break flag bit (BKF) in SCS2
- May set the overrun (OR), noise flag (NF), parity error (PE), or reception-in-progress flag (RPF) bits

13.3.2.4 Idle Characters

An idle character contains all 1s and has no start, stop, or parity bit. Idle character length depends on the M bit in SCC1. The preamble is a synchronizing idle character that begins every transmission.

If the TE bit is cleared during a transmission, the PTF5/TxD pin becomes idle after completion of the transmission in progress. Clearing and then setting the TE bit during a transmission queues an idle character to be sent after the character currently being transmitted.

NOTE: *When a break sequence is followed immediately by an idle character, this SCI design exhibits a condition in which the break character length is reduced by one half bit time. In this instance, the break sequence will consist of a valid start bit, eight or nine data bits (as defined by the M bit in SCC1) of logic 0 and one half data bit length of logic 0 in the stop bit position followed immediately by the idle character. To ensure a break character of the proper length is transmitted, always queue up a byte of data to be transmitted while the final break sequence is in progress.*

When queueing an idle character, return the TE bit to 1 before the stop bit of the current character shifts out to the PTF5/TxD pin. Setting TE after the stop bit appears on PTF5/TxD causes data previously written to the SCDR to be lost.

A good time to toggle the TE bit is when the SCTE bit becomes set and just before writing the next byte to the SCDR.

13.3.2.5 Inversion of Transmitted Output

The transmit inversion bit (TXINV) in SCI control register 1 (SCC1) reverses the polarity of transmitted data. All transmitted values, including idle, break, start, and stop bits, are inverted when TXINV is at 1. See [13.7.1 SCI Control Register 1](#).

13.3.2.6 Transmitter Interrupts

These conditions can generate CPU interrupt requests from the SCI transmitter:

- SCI transmitter empty (SCTE) — The SCTE bit in SCS1 indicates that the SCDR has transferred a character to the transmit shift register. SCTE can generate a transmitter CPU interrupt request. Setting the SCI transmit interrupt enable bit, SCTIE, in SCC2 enables the SCTE bit to generate transmitter CPU interrupt requests.
- Transmission complete (TC) — The TC bit in SCS1 indicates that the transmit shift register and the SCDR are empty and that no break or idle character has been generated. The transmission complete interrupt enable bit, TCIE, in SCC2 enables the TC bit to generate transmitter CPU interrupt requests.

13.3.3 Receiver

Figure 13-6 shows the structure of the SCI receiver.

13.3.3.1 Character Length

The receiver can accommodate either 8-bit or 9-bit data. The state of the M bit in SCI control register 1 (SCC1) determines character length. When receiving 9-bit data, bit R8 in SCI control register 2 (SCC2) is the ninth bit (bit 8). When receiving 8-bit data, bit R8 is a copy of the eighth bit (bit 7).

13.3.3.2 Character Reception

During an SCI reception, the receive shift register shifts characters in from the PTF4/RxD pin. The SCI data register (SCDR) is the read-only buffer between the internal data bus and the receive shift register.

After a complete character shifts into the receive shift register, the data portion of the character transfers to the SCDR. The SCI receiver full bit, SCRFB, in SCI status register 1 (SCS1) becomes set, indicating that the received byte can be read. If the SCI receive interrupt enable bit, SCRIB, in SCC2 is also set, the SCRFB bit generates a receiver CPU interrupt request.

13.3.3.3 Data Sampling

The receiver samples the PTF4/RxD pin at the RT clock rate. The RT clock is an internal signal with a frequency 16 times the baud rate. To adjust for baud rate mismatch, the RT clock is resynchronized at these times (see **Figure 13-7**):

- After every start bit
- After the receiver detects a data bit change from 1 to 0 (after the majority of data bit samples at RT8, RT9, and RT10 return a valid 1 and the majority of the next RT8, RT9, and RT10 samples return a valid 0)

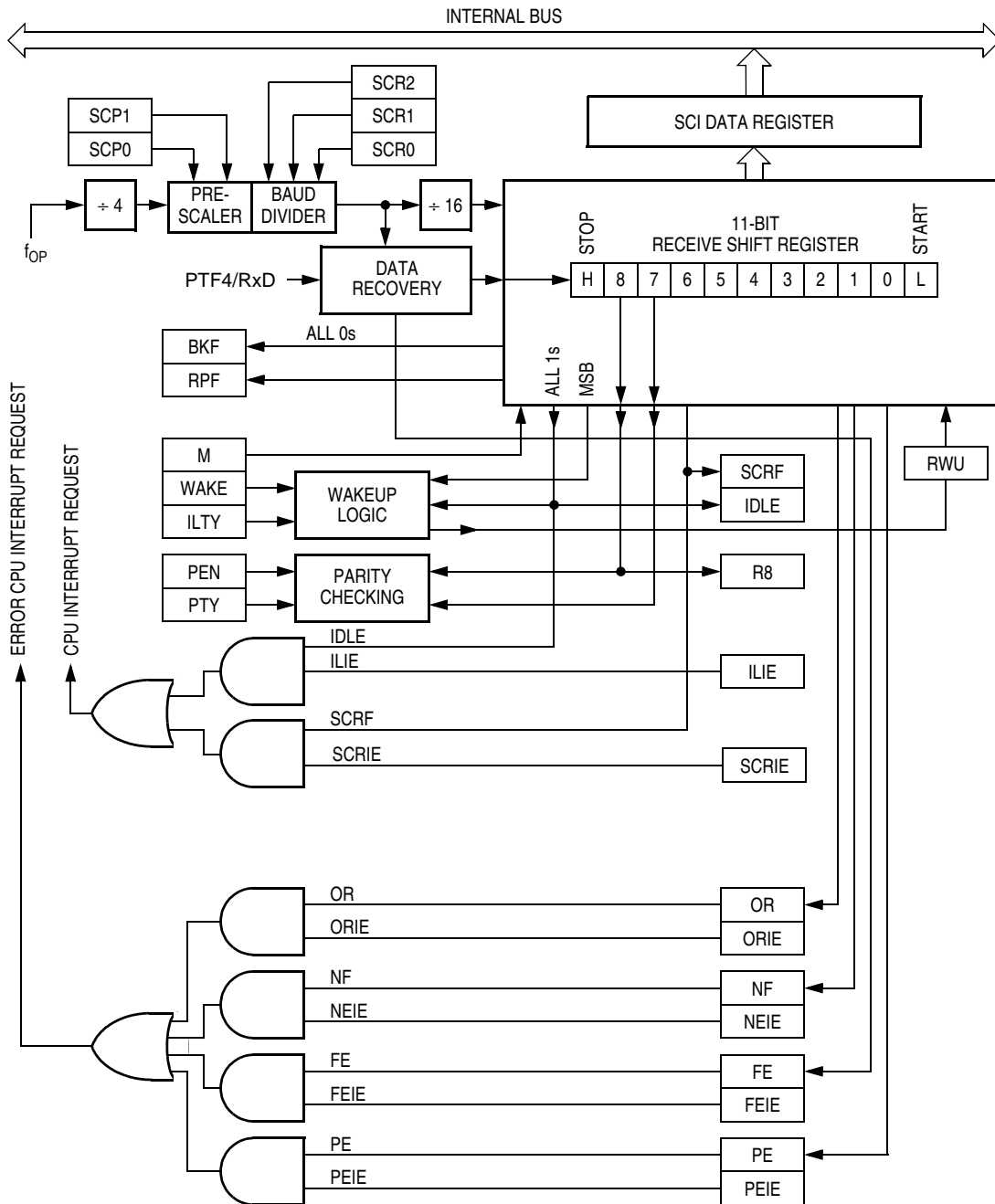

Figure 13-6. SCI Receiver Block Diagram

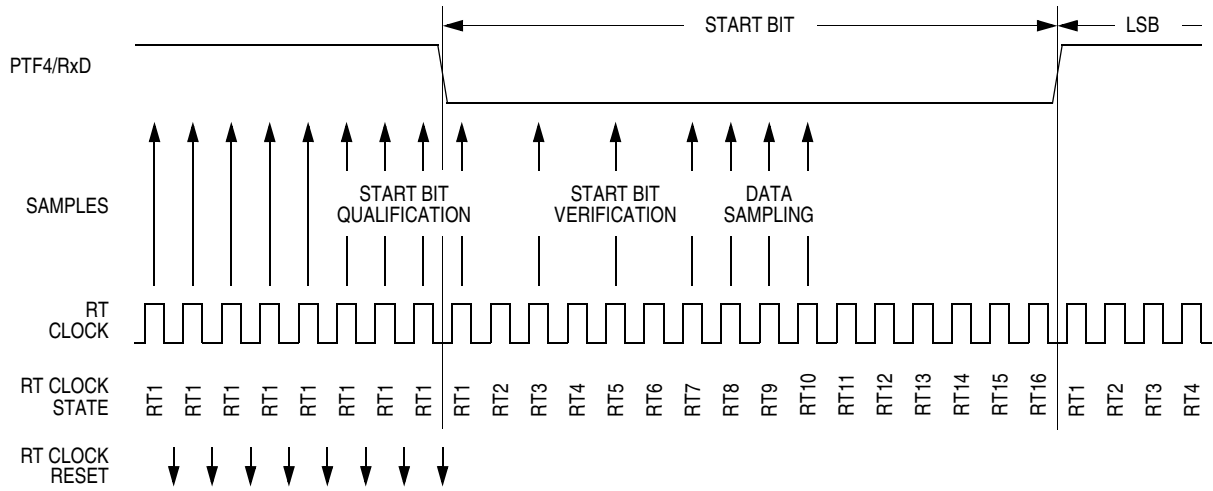

Figure 13-7. Receiver Data Sampling

To locate the start bit, data recovery logic does an asynchronous search for a 0 preceded by three 1s. When the falling edge of a possible start bit occurs, the RT clock begins to count to 16.

To verify the start bit and to detect noise, data recovery logic takes samples at RT3, RT5, and RT7. Table 13-1 summarizes the results of the start bit verification samples.

Table 13-1. Start Bit Verification

RT3, RT5, and RT7 Samples	Start Bit Verification	Noise Flag
000	Yes	0
001	Yes	1
010	Yes	1
011	No	0
100	Yes	1
101	No	0
110	No	0
111	No	0

If start bit verification is not successful, the RT clock is reset and a new search for a start bit begins.

To determine the value of a data bit and to detect noise, recovery logic takes samples at RT8, RT9, and RT10. **Table 13-2** summarizes the results of the data bit samples.

Table 13-2. Data Bit Recovery

RT8, RT9, and RT10 Samples	Data Bit Determination	Noise Flag
000	0	0
001	0	1
010	0	1
011	1	1
100	0	1
101	1	1
110	1	1
111	1	0

NOTE: *The RT8, RT9, and RT10 samples do not affect start bit verification. If any or all of the RT8, RT9, and RT10 start bit samples are 1s following a successful start bit verification, the noise flag (NF) is set and the receiver assumes that the bit is a start bit.*

To verify a stop bit and to detect noise, recovery logic takes samples at RT8, RT9, and RT10. **Table 13-3** summarizes the results of the stop bit samples.

Table 13-3. Stop Bit Recovery

RT8, RT9, and RT10 Samples	Framing Error Flag	Noise Flag
000	1	0
001	1	1
010	1	1
011	0	1
100	1	1
101	0	1
110	0	1
111	0	0

13.3.3.4 Framing Errors

If the data recovery logic does not detect a 1 where the stop bit should be in an incoming character, it sets the framing error bit, FE, in SCS1. The FE flag is set at the same time that the SCRF bit is set. A break character that has no stop bit also sets the FE bit.

13.3.3.5 Receiver Wakeup

So that the MCU can ignore transmissions intended only for other receivers in multiple-receiver systems, the receiver can be put into a standby state. Setting the receiver wakeup bit, RWU, in SCC2 puts the receiver into a standby state during which receiver interrupts are disabled.

Depending on the state of the WAKE bit in SCC1, either of two conditions on the PTF4/RxD pin can bring the receiver out of the standby state:

- Address mark — An address mark is a 1 in the most significant bit position of a received character. When the WAKE bit is set, an address mark wakes the receiver from the standby state by clearing the RWU bit. The address mark also sets the SCI receiver full bit, SCRF. Software can then compare the character containing the address mark to the user-defined address of the receiver. If they are the same, the receiver remains awake and processes the characters that follow. If they are not the same, software can set the RWU bit and put the receiver back into the standby state.
- Idle input line condition — When the WAKE bit is clear, an idle character on the PTF4/RxD pin wakes the receiver from the standby state by clearing the RWU bit. The idle character that wakes the receiver does not set the receiver idle bit, IDLE, or the SCI receiver full bit, SCRF. The idle line type bit, ILTY, determines whether the receiver begins counting 1s as idle character bits after the start bit or after the stop bit.

NOTE: Clearing the WAKE bit after the PTF4/RxD pin has been idle can cause the receiver to wake up immediately.

13.3.3.6 Receiver Interrupts

These sources can generate CPU interrupt requests from the SCI receiver:

- SCI receiver full (SCRF) — The SCRF bit in SCS1 indicates that the receive shift register has transferred a character to the SCDR. SCRF can generate a receiver CPU interrupt request. Setting the SCI receive interrupt enable bit, SCRIE, in SCC2 enables the SCRF bit to generate receiver CPU interrupts.
- Idle input (IDLE) — The IDLE bit in SCS1 indicates that 10 or 11 consecutive 1s shifted in from the PTF4/RxD pin. The idle line interrupt enable bit, ILIE, in SCC2 enables the IDLE bit to generate CPU interrupt requests.

13.3.3.7 Error Interrupts

These receiver error flags in SCS1 can generate CPU interrupt requests:

- Receiver overrun (OR) — The OR bit indicates that the receive shift register shifted in a new character before the previous character was read from the SCDR. The previous character remains in the SCDR, and the new character is lost. The overrun interrupt enable bit, ORIE, in SCC3 enables OR to generate SCI error CPU interrupt requests.
- Noise flag (NF) — The NF bit is set when the SCI detects noise on incoming data or break characters, including start, data, and stop bits. The noise error interrupt enable bit, NEIE, in SCC3 enables NF to generate SCI error CPU interrupt requests.
- Framing error (FE) — The FE bit in SCS1 is set when a 0 occurs where the receiver expects a stop bit. The framing error interrupt enable bit, FEIE, in SCC3 enables FE to generate SCI error CPU interrupt requests.
- Parity error (PE) — The PE bit in SCS1 is set when the SCI detects a parity error in incoming data. The parity error interrupt enable bit, PEIE, in SCC3 enables PE to generate SCI error CPU interrupt requests.

13.4 Wait Mode

The WAIT and STOP instructions put the MCU in low power-consumption standby modes.

The SCI module remains active after the execution of a WAIT instruction. In wait mode the SCI module registers are not accessible by the CPU. Any enabled CPU interrupt request from the SCI module can bring the MCU out of wait mode.

If SCI module functions are not required during wait mode, reduce power consumption by disabling the module before executing the WAIT instruction.

13.5 SCI During Break Module Interrupts

The system integration module (SIM) controls whether status bits in other modules can be cleared during interrupts generated by the break module. The BCFE bit in the SIM break flag control register (SBFCR) enables software to clear status bits during the break state.

To allow software to clear status bits during a break interrupt, write a 1 to the BCFE bit. If a status bit is cleared during the break state, it remains cleared when the MCU exits the break state.

To protect status bits during the break state, write a 0 to the BCFE bit. With BCFE at 0 (its default state), software can read and write I/O registers during the break state without affecting status bits. Some status bits have a 2-step read/write clearing procedure. If software does the first step on such a bit before the break, the bit cannot change during the break state as long as BCFE is at 0. After the break, doing the second step clears the status bit.

13.6 I/O Signals

Port F shares two of its pins with the SCI module. The two SCI input/output (I/O) pins are:

- PTF5/TxD — Transmit data
- PTF4/RxD — Receive data

13.6.1 PTF5/TxD (Transmit Data)

The PTF5/TxD pin is the serial data output from the SCI transmitter. The SCI shares the PTF5/TxD pin with port F. When the SCI is enabled, the PTF5/TxD pin is an output regardless of the state of the DDRF5 bit in data direction register F (DDRF).

13.6.2 PTF4/RxD (Receive Data)

The PTF4/RxD pin is the serial data input to the SCI receiver. The SCI shares the PTF4/RxD pin with port F. When the SCI is enabled, the PTF4/RxD pin is an input regardless of the state of the DDRF4 bit in data direction register F (DDRF).

13.7 I/O Registers

These I/O registers control and monitor SCI operation:

- SCI control register 1 (SCC1)
- SCI control register 2 (SCC2)
- SCI control register 3 (SCC3)
- SCI status register 1 (SCS1)
- SCI status register 2 (SCS2)
- SCI data register (SCDR)
- SCI baud rate register (SCBR)

13.7.1 SCI Control Register 1

SCI control register 1 (SCC1):

- Enables loop-mode operation
- Enables the SCI
- Controls output polarity
- Controls character length
- Controls SCI wakeup method
- Controls idle character detection
- Enables parity function
- Controls parity type

Address: \$0038

	Bit 7	6	5	4	3	2	1	Bit 0
Read:	LOOPS	ENSCI	TXINV	M	WAKE	ILTY	PEN	PTY
Write:								
Reset:	0	0	0	0	0	0	0	0

Figure 13-8. SCI Control Register 1 (SCC1)

LOOPS — Loop Mode Select Bit

This read/write bit enables loop mode operation. In loop mode the PTF4/RxD pin is disconnected from the SCI, and the transmitter output goes into the receiver input. Both the transmitter and the receiver must be enabled to use loop mode. Reset clears the LOOPS bit.

- 1 = Loop mode enabled
- 0 = Normal operation enabled

ENSCI — Enable SCI Bit

This read/write bit enables the SCI and the SCI baud rate generator. Clearing ENSCI sets the SCTE and TC bits in SCI status register 1 and disables transmitter interrupts. Reset clears the ENSCI bit.

- 1 = SCI enabled
- 0 = SCI disabled

TXINV — Transmit Inversion Bit

This read/write bit reverses the polarity of transmitted data. Reset clears the TXINV bit.

- 1 = Transmitter output inverted
- 0 = Transmitter output not inverted

NOTE: Setting the TXINV bit inverts all transmitted values, including idle, break, start, and stop bits.

M — Mode (Character Length) Bit

This read/write bit determines whether SCI characters are eight or nine bits long. See [Table 13-4](#). The ninth bit can serve as an extra stop bit, as a receiver wakeup signal, or as a parity bit. Reset clears the M bit.

- 1 = 9-bit SCI characters
- 0 = 8-bit SCI characters

WAKE — Wakeup Condition Bit

This read/write bit determines which condition wakes up the SCI: a 1 (address mark) in the most significant bit (MSB) position of a received character or an idle condition on the PTF4/RxD pin. Reset clears the WAKE bit.

- 1 = Address mark wakeup
- 0 = Idle line wakeup

ILTY — Idle Line Type Bit

This read/write bit determines when the SCI starts counting 1s as idle character bits. The counting begins either after the start bit or after the stop bit. If the count begins after the start bit, then a string of 1s preceding the stop bit may cause false recognition of an idle character. Beginning the count after the stop bit avoids false idle character recognition, but requires properly synchronized transmissions. Reset clears the ILTY bit.

- 1 = Idle character bit count begins after stop bit.
- 0 = Idle character bit count begins after start bit.

PEN — Parity Enable Bit

This read/write bit enables the SCI parity function. See [Table 13-4](#). When enabled, the parity function inserts a parity bit in the most significant bit position. See [Figure 13-4](#). Reset clears the PEN bit.

- 1 = Parity function enabled
- 0 = Parity function disabled

PTY — Parity Bit

This read/write bit determines whether the SCI generates and checks for odd parity or even parity. See [Table 13-4](#). Reset clears the PTY bit.

- 1 = Odd parity
- 0 = Even parity

NOTE: Changing the PTY bit in the middle of a transmission or reception can generate a parity error.

Table 13-4. Character Format Selection

Control Bits		Character Format				
M	PEN:PTY	Start Bits	Data Bits	Parity	Stop Bits	Character Length
0	0X	1	8	None	1	10 bits
1	0X	1	9	None	1	11 bits
0	10	1	7	Even	1	10 bits
0	11	1	7	Odd	1	10 bits
1	10	1	8	Even	1	11 bits
1	11	1	8	Odd	1	11 bits

13.7.2 SCI Control Register 2

SCI control register 2 (SCC2):

- Enables these CPU interrupt requests:
 - Enables the SCTE bit to generate transmitter CPU interrupt requests
 - Enables the TC bit to generate transmitter CPU interrupt requests
 - Enables the SCRF bit to generate receiver CPU interrupt requests
 - Enables the IDLE bit to generate receiver CPU interrupt requests
- Enables the transmitter
- Enables the receiver
- Enables SCI wakeup
- Transmits SCI break characters

Address: \$0039

	Bit 7	6	5	4	3	2	1	Bit 0
Read:	SCTIE	TCIE	SCRIE	ILIE	TE	RE	RWU	SBK
Write:								
Reset:	0	0	0	0	0	0	0	0

Figure 13-9. SCI Control Register 2 (SCC2)

SCTIE — SCI Transmit Interrupt Enable Bit

This read/write bit enables the SCTE bit to generate SCI transmitter CPU interrupt requests. Setting the SCTIE bit in SCC3 enables SCTE CPU interrupt requests. Reset clears the SCTIE bit.

- 1 = SCTE enabled to generate CPU interrupt
- 0 = SCTE not enabled to generate CPU interrupt

TCIE — Transmission Complete Interrupt Enable Bit

This read/write bit enables the TC bit to generate SCI transmitter CPU interrupt requests. Reset clears the TCIE bit.

- 1 = TC enabled to generate CPU interrupt requests
- 0 = TC not enabled to generate CPU interrupt requests

SCRIE — SCI Receive Interrupt Enable Bit

This read/write bit enables the SCRF bit to generate SCI receiver CPU interrupt requests. Setting the SCRIE bit in SCC3 enables the SCRF bit to generate CPU interrupt requests. Reset clears the SCRIE bit.

- 1 = SCRF enabled to generate CPU interrupt
- 0 = SCRF not enabled to generate CPU interrupt

ILIE — Idle Line Interrupt Enable Bit

This read/write bit enables the IDLE bit to generate SCI receiver CPU interrupt requests. Reset clears the ILIE bit.

- 1 = IDLE enabled to generate CPU interrupt requests
- 0 = IDLE not enabled to generate CPU interrupt requests

TE — Transmitter Enable Bit

Setting this read/write bit begins the transmission by sending a preamble of 10 or 11 1s from the transmit shift register to the PTF5/TxD pin. If software clears the TE bit, the transmitter completes any transmission in progress before the PTF5/TxD returns to the idle condition (logic 1). Clearing and then setting TE during a transmission queues an idle character to be sent after the character currently being transmitted. Reset clears the TE bit.

- 1 = Transmitter enabled
- 0 = Transmitter disabled

NOTE: *Writing to the TE bit is not allowed when the enable SCI bit (ENSCI) is clear. ENSCI is in SCI control register 1.*

RE — Receiver Enable Bit

Setting this read/write bit enables the receiver. Clearing the RE bit disables the receiver but does not affect receiver interrupt flag bits. Reset clears the RE bit.

- 1 = Receiver enabled
- 0 = Receiver disabled

NOTE: *Writing to the RE bit is not allowed when the enable SCI bit (ENSCI) is clear. ENSCI is in SCI control register 1.*

RWU — Receiver Wakeup Bit

This read/write bit puts the receiver in a standby state during which receiver interrupts are disabled. The WAKE bit in SCC1 determines whether an idle input or an address mark brings the receiver out of the standby state and clears the RWU bit. Reset clears the RWU bit.

- 1 = Standby state
- 0 = Normal operation

SBK — Send Break Bit

Setting and then clearing this read/write bit transmits a break character followed by a 1. The 1 after the break character guarantees recognition of a valid start bit. If SBK remains set, the transmitter continuously transmits break characters with no 1s between them. Reset clears the SBK bit.

- 1 = Transmit break characters
- 0 = No break characters being transmitted

NOTE: *Do not toggle the SBK bit immediately after setting the SCTE bit. Toggling SBK too early causes the SCI to send a break character instead of a preamble.*

13.7.3 SCI Control Register 3

SCI control register 3 (SCC3):

- Stores the ninth SCI data bit received and the ninth SCI data bit to be transmitted
- Enables SCI receiver full (SCRF)
- Enables SCI transmitter empty (SCTE)
- Enables the following interrupts:
 - Receiver overrun interrupts
 - Noise error interrupts
 - Framing error interrupts
 - Parity error interrupts

Address: \$003A

	Bit 7	6	5	4	3	2	1	Bit 0
Read:	R8	T8	0	0	ORIE	NEIE	FEIE	PEIE
Write:	R		R	R				
Reset:	U	U	0	0	0	0	0	0

R = Reserved U = Unaffected

Figure 13-10. SCI Control Register 3 (SCC3)

R8 — Received Bit 8

When the SCI is receiving 9-bit characters, R8 is the read-only ninth bit (bit 8) of the received character. R8 is received at the same time that the SCDR receives the other eight bits.

When the SCI is receiving 8-bit characters, R8 is a copy of the eighth bit (bit 7). Reset has no effect on the R8 bit.

T8 — Transmitted Bit 8

When the SCI is transmitting 9-bit characters, T8 is the read/write ninth bit (bit 8) of the transmitted character. T8 is loaded into the transmit shift register at the same time that the SCDR is loaded into the transmit shift register. Reset has no effect on the T8 bit.

ORIE — Receiver Overrun Interrupt Enable Bit

This read/write bit enables SCI error CPU interrupt requests generated by the receiver overrun bit, OR.

- 1 = SCI error CPU interrupt requests from OR bit enabled
- 0 = SCI error CPU interrupt requests from OR bit disabled

NEIE — Receiver Noise Error Interrupt Enable Bit

This read/write bit enables SCI error CPU interrupt requests generated by the noise error bit, NE. Reset clears NEIE.

- 1 = SCI error CPU interrupt requests from NE bit enabled
- 0 = SCI error CPU interrupt requests from NE bit disabled

FEIE — Receiver Framing Error Interrupt Enable Bit

This read/write bit enables SCI error CPU interrupt requests generated by the framing error bit, FE. Reset clears FEIE.

- 1 = SCI error CPU interrupt requests from FE bit enabled
- 0 = SCI error CPU interrupt requests from FE bit disabled

PEIE — Receiver Parity Error Interrupt Enable Bit

This read/write bit enables SCI receiver CPU interrupt requests generated by the parity error bit, PE. See **13.7.4 SCI Status Register 1**. Reset clears PEIE.

- 1 = SCI error CPU interrupt requests from PE bit enabled
- 0 = SCI error CPU interrupt requests from PE bit disabled

13.7.4 SCI Status Register 1

SCI status register 1 (SCS1) contains flags to signal these conditions:

- Transfer of SCDR data to transmit shift register complete
- Transmission complete
- Transfer of receive shift register data to SCDR complete
- Receiver input idle
- Receiver overrun
- Noisy data
- Framing error
- Parity error

Address: \$003B

	Bit 7	6	5	4	3	2	1	Bit 0
Read:	SCTE	TC	SCRF	IDLE	OR	NF	FE	PE
Write:	R	R	R	R	R	R	R	R
Reset:	1	1	0	0	0	0	0	0

R = Reserved

Figure 13-11. SCI Status Register 1 (SCS1)

SCTE — SCI Transmitter Empty Bit

This clearable, read-only bit is set when the SCDR transfers a character to the transmit shift register. SCTE can generate an SCI transmitter CPU interrupt request. When the SCTIE bit in SCC2 is set, SCTE generates an SCI transmitter CPU interrupt request. In normal operation, clear the SCTE bit by reading SCS1 with SCTE set and then writing to SCDR. Reset sets the SCTE bit.

- 1 = SCDR data transferred to transmit shift register
- 0 = SCDR data not transferred to transmit shift register

TC — Transmission Complete Bit

This read-only bit is set when the SCTE bit is set and no data, preamble, or break character is being transmitted. TC generates an SCI transmitter CPU interrupt request if the TCIE bit in SCC2 is also set. TC is cleared automatically when data, preamble, or break is queued and ready to be sent. There may be up to 1.5 transmitter clocks of latency between queueing data, preamble, and break and the transmission actually starting. Reset sets the TC bit.

1 = No transmission in progress

0 = Transmission in progress

SCRF — SCI Receiver Full Bit

This clearable, read-only bit is set when the data in the receive shift register transfers to the SCI data register. SCRF can generate an SCI receiver CPU interrupt request. When the SCRIE bit in SCC2 is set, SCRF generates a CPU interrupt request. In normal operation, clear the SCRF bit by reading SCS1 with SCRF set and then reading the SCDR. Reset clears SCRF.

1 = Received data available in SCDR

0 = Data not available in SCDR

IDLE — Receiver Idle Bit

This clearable, read-only bit is set when 10 or 11 consecutive 1s appear on the receiver input. IDLE generates an SCI error CPU interrupt request if the ILIE bit in SCC2 is also set. Clear the IDLE bit by reading SCS1 with IDLE set and then reading the SCDR. After the receiver is enabled, it must receive a valid character that sets the SCRF bit before an idle condition can set the IDLE bit. Also, after the IDLE bit has been cleared, a valid character must again set the SCRF bit before an idle condition can set the IDLE bit. Reset clears the IDLE bit.

1 = Receiver input idle

0 = Receiver input active or idle since the IDLE bit was cleared

OR — Receiver Overrun Bit

This clearable, read-only bit is set when software fails to read the SCDR before the receive shift register receives the next character. The OR bit generates an SCI error CPU interrupt request if the ORIE bit in SCC3 is also set. The data in the shift register is lost, but the data already in the SCDR is not affected. Clear the OR bit by reading SCS1 with OR set and then reading the SCDR. Reset clears the OR bit.

1 = Receive shift register full and SCRF = 1

0 = No receiver overrun

Software latency may allow an overrun to occur between reads of SCS1 and SCDR in the flag-clearing sequence. **Figure 13-12** shows the normal flag-clearing sequence and an example of an overrun caused by a delayed flag-clearing sequence. The delayed read of SCDR does not clear the OR bit because OR was not set when SCS1 was read. Byte 2 caused the overrun and is lost. The next flag-clearing sequence reads byte 3 in the SCDR instead of byte 2.

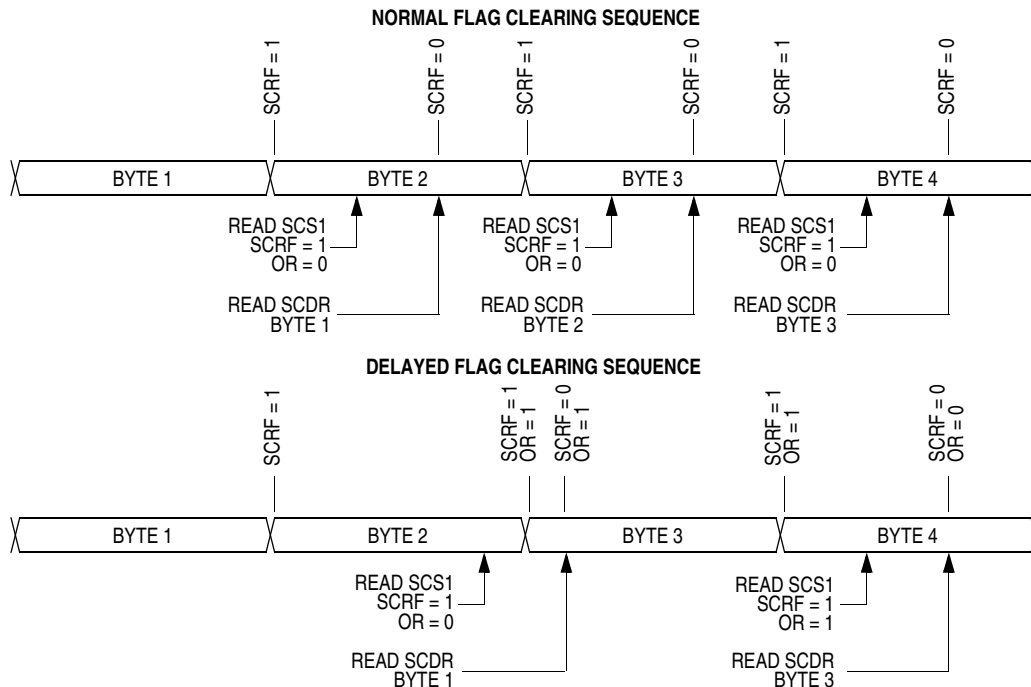

Figure 13-12. Flag Clearing Sequence

In applications that are subject to software latency or in which it is important to know which byte is lost due to an overrun, the flag-clearing routine can check the OR bit in a second read of SCS1 after reading the data register.

NF — Receiver Noise Flag Bit

This clearable, read-only bit is set when the SCI detects noise on the PTF4/RxD pin. NF generates an NF CPU interrupt request if the NEIE bit in SCC3 is also set. Clear the NF bit by reading SCS1 and then reading the SCDR. Reset clears the NF bit.

- 1 = Noise detected
- 0 = No noise detected

FE — Receiver Framing Error Bit

This clearable, read-only bit is set when a 0 is accepted as the stop bit. FE generates an SCI error CPU interrupt request if the FEIE bit in SCC3 also is set. Clear the FE bit by reading SCS1 with FE set and then reading the SCDR. Reset clears the FE bit.

- 1 = Framing error detected
- 0 = No framing error detected

PE — Receiver Parity Error Bit

This clearable, read-only bit is set when the SCI detects a parity error in incoming data. PE generates a PE CPU interrupt request if the PEIE bit in SCC3 is also set. Clear the PE bit by reading SCS1 with PE set and then reading the SCDR. Reset clears the PE bit.

- 1 = Parity error detected
- 0 = No parity error detected

13.7.5 SCI Status Register 2

SCI status register 2 (SCS2) contains flags to signal these conditions:

- Break character detected
- Incoming data

Address: \$003C

	Bit 7	6	5	4	3	2	1	Bit 0
Read:	0	0	0	0	0	0	BKF	RPF
Write:	R	R	R	R	R	R	R	R
Reset:	0	0	0	0	0	0	0	0

R = Reserved

Figure 13-13. SCI Status Register 2 (SCS2)

BKF — Break Flag

This clearable, read-only bit is set when the SCI detects a break character on the PTF4/RxD pin. In SCS1, the FE and SCRF bits are also set. In 9-bit character transmissions, the R8 bit in SCC3 is cleared. BKF does not generate a CPU interrupt request. Clear BKF by reading SCS2 with BKF set and then reading the SCDR. Once cleared, BKF can become set again only after logic 1s again appear on the PTF4/RxD pin followed by another break character. Reset clears the BKF bit.

- 1 = Break character detected
- 0 = No break character detected

RPF —Reception-in-Progress Flag

This read-only bit is set when the receiver detects a logic 0 during the RT1 time period of the start bit search. RPF does not generate an interrupt request. RPF is reset after the receiver detects false start bits (usually from noise or a baud rate mismatch, or when the receiver detects an idle character. Polling RPF before disabling the SCI module or entering stop mode can show whether a reception is in progress.

- 1 = Reception in progress
- 0 = No reception in progress

Serial Communications Interface Module (SCI)

13.7.6 SCI Data Register

The SCI data register (SCDR) is the buffer between the internal data bus and the receive and transmit shift registers. Reset has no effect on data in the SCI data register.

Address: \$003D

	Bit 7	6	5	4	3	2	1	Bit 0
Read:	R7	R6	R5	R4	R3	R2	R1	R0
Write:	T7	T6	T5	T4	T3	T2	T1	T0
Reset:	Unaffected by reset							

Figure 13-14. SCI Data Register (SCDR)

R7/T7:R0/T0 — Receive/Transmit Data Bits

Reading address \$003D accesses the read-only received data bits, R7:R0. Writing to address \$003D writes the data to be transmitted, T7:T0. Reset has no effect on the SCI data register.

13.7.7 SCI Baud Rate Register

The baud rate register (SCBR) selects the baud rate for both the receiver and the transmitter.

Address: \$003E

	Bit 7	6	5	4	3	2	1	Bit 0
Read:	0	0	SCP1	SCP0	0	SCR2	SCR1	SCR0
Write:	R	R			R			
Reset:	0	0	0	0	0	0	0	0

R = Reserved

Figure 13-15. SCI Baud Rate Register (SCBR)

SCP1 and SCP0 — SCI Baud Rate Prescaler Bits

These read/write bits select the baud rate prescaler divisor as shown in Table 13-5. Reset clears SCP1 and SCP0.

Table 13-5. SCI Baud Rate Prescaling

SCP1:SCP0	Prescaler Divisor (PD)
00	1
01	3
10	4
11	13

SCR2–SCR0 — SCI Baud Rate Select Bits

These read/write bits select the SCI baud rate divisor as shown in [Table 13-6](#). Reset clears SCR2–SCR0.

Table 13-6. SCI Baud Rate Selection

SCR2:SCR1:SCR0	Baud Rate Divisor (BD)
000	1
001	2
010	4
011	8
100	16
101	32
110	64
111	128

Use this formula to calculate the SCI baud rate:

$$\text{Baud rate} = \frac{f_{\text{OP}}}{64 \times \text{PD} \times \text{BD}}$$

where:

- f_{OP} = internal operating frequency
- PD = prescaler divisor
- BD = baud rate divisor

[Table 13-7](#) shows the SCI baud rates that can be generated with a 4.9152-MHz crystal with the CGM set for an f_{OP} of 7.3728 MHz and the CGM set for an f_{OP} of 4.9152 MHz.

Table 13-7. SCI Baud Rate Selection Examples

SCP1:SCP0	Prescaler Divisor (PD)	SCR2:SCR1:SCR0	Baud Rate Divisor (BD)	Baud Rate (f _{OP} = 7.3728 MHz)	Baud Rate (f _{OP} = 4.9152 MHz)
00	1	000	1	115,200	76,800
00	1	001	2	57,600	38,400
00	1	010	4	28,800	19,200
00	1	011	8	14,400	9600
00	1	100	16	7200	4800
00	1	101	32	3600	2400
00	1	110	64	1800	1200
00	1	111	128	900	600
01	3	000	1	38,400	25,600
01	3	001	2	19,200	12,800
01	3	010	4	9600	6400
01	3	011	8	4800	3200
01	3	100	16	2400	1600
01	3	101	32	1200	800
01	3	110	64	600	400
01	3	111	128	300	200
10	4	000	1	28,800	19,200
10	4	001	2	14,400	9600
10	4	010	4	7200	4800
10	4	011	8	3600	2400
10	4	100	16	1800	1200
10	4	101	32	900	600
10	4	110	64	450	300
10	4	111	128	225	150
11	13	000	1	8861.5	5907.7
11	13	001	2	4430.7	2953.8
11	13	010	4	2215.4	1476.9
11	13	011	8	1107.7	738.5
11	13	100	16	553.8	369.2
11	13	101	32	276.9	184.6
11	13	110	64	138.5	92.3
11	13	111	128	69.2	46.2

Section 14. System Integration Module (SIM)

14.1 Introduction

This section describes the system integration module (SIM). Together with the central processor unit (CPU), the SIM controls all microcontroller unit (MCU) activities.

A block diagram of the SIM is shown in [Figure 14-1](#).

The SIM is a system state controller that coordinates CPU and exception timing. The SIM is responsible for:

- Bus clock generation and control for CPU and peripherals:
 - Wait/reset/break entry and recovery
 - Internal clock control
- Master reset control, including power-on reset (POR) and computer operating properly (COP) timeout
- Interrupt control:
 - Acknowledge timing
 - Arbitration control timing
 - Vector address generation
- CPU enable/disable timing
- Modular architecture expandable to 128 interrupt sources

[Table 14-1](#) shows the internal signal names used in this section.

System Integration Module (SIM)

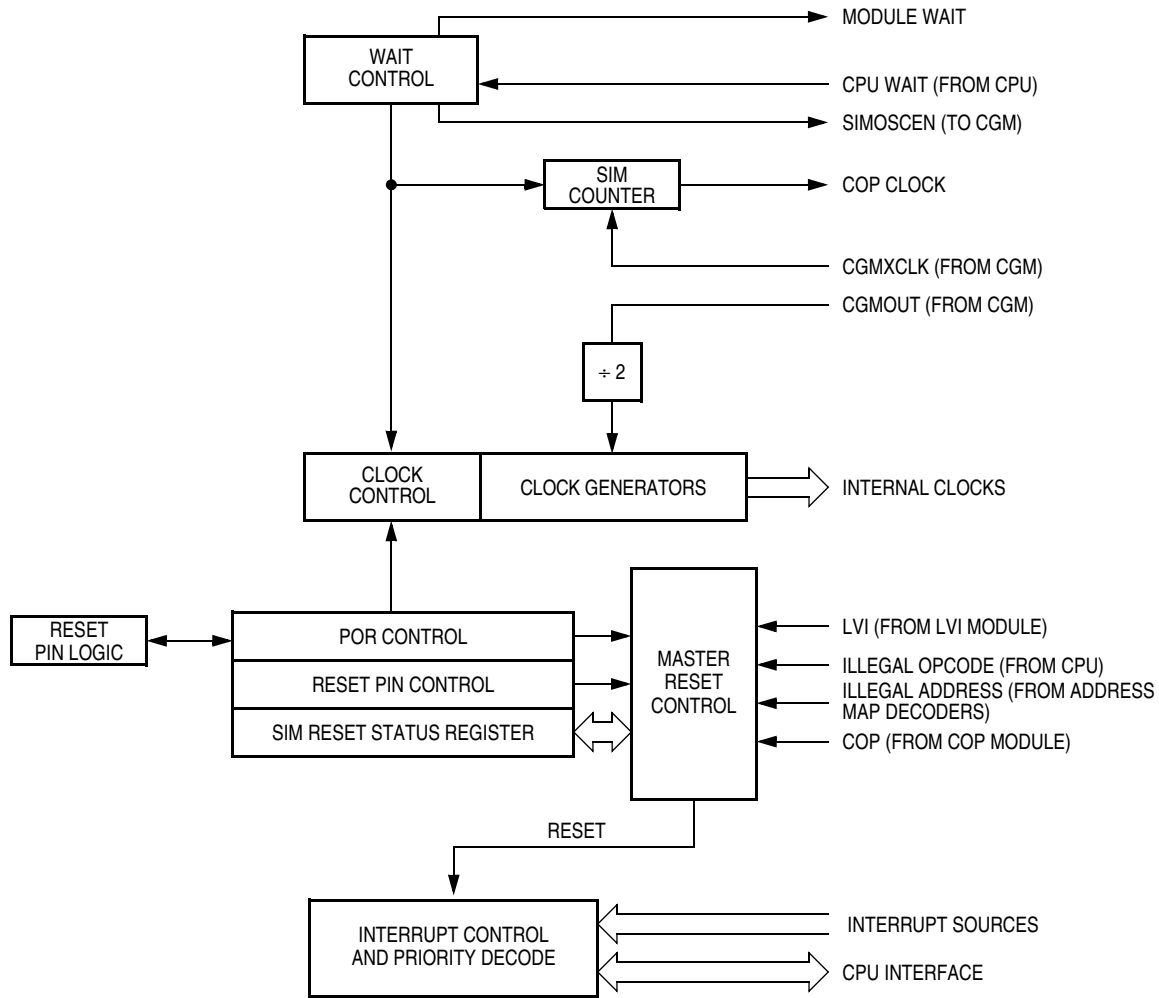

Figure 14-1. SIM Block Diagram

Table 14-1. Signal Name Conventions

Signal Name	Description
CGMXCLK	Buffered version of OSC1 from clock generator module (CGM)
CGMVCLK	Phase-locked loop (PLL) circuit output
CGMOUT	PLL-based or OSC1-based clock output from CGM module (bus clock = CGMOUT divided by two)
IAB	Internal address bus
IDB	Internal data bus
PORRST	Signal from the power-on reset module to the SIM
IRST	Internal reset signal
R/ \bar{W}	Read/write signal

14.2 SIM Bus Clock Control and Generation

The bus clock generator provides system clock signals for the CPU and peripherals on the MCU. The system clocks are generated from an incoming clock, CGMOUT, as shown in [Figure 14-2](#). This clock can come from either an external oscillator or from the on-chip phase-locked loop (PLL) circuit. See [Section 4. Clock Generator Module \(CGM\)](#).

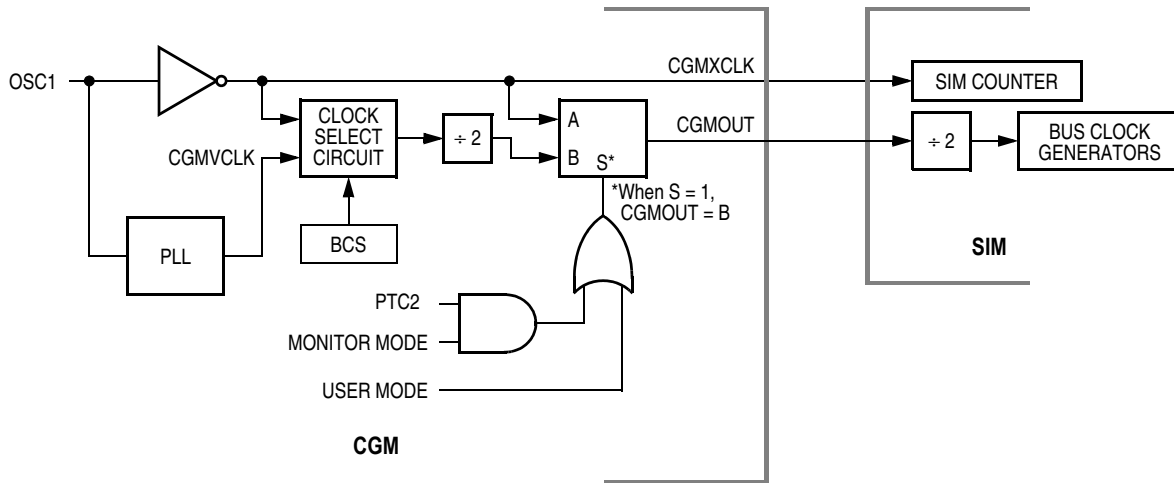

Figure 14-2. CGM Clock Signals

14.2.1 Bus Timing

In user mode, the internal bus frequency is either the crystal oscillator output (CGMXCLK) divided by four or the PLL output (CGMVCLK) divided by four. See [Section 4. Clock Generator Module \(CGM\)](#).

14.2.2 Clock Startup from POR or LVI Reset

When the power-on reset (POR) module or the low-voltage inhibit (LVI) module generates a reset, the clocks to the CPU and peripherals are inactive and held in an inactive phase until after the 4096 CGMXCLK cycle POR timeout has completed. The \overline{RST} pin is driven low by the SIM during this entire period. The internal bus (IBUS) clocks start upon completion of the timeout.

14.2.3 Clocks in Wait Mode

In wait mode, the CPU clocks are inactive. The SIM also produces two sets of clocks for other modules. Refer to the wait mode subsection of each module to see if the module is active or inactive in wait mode. Some modules can be programmed to be active in wait mode.

14.3 Reset and System Initialization

The MCU has these reset sources:

- Power-on reset module (POR)
- External reset pin (\overline{RST})
- Computer operating properly (COP) module
- Low-voltage inhibit (LVI) module
- Illegal opcode
- Illegal address

All of these resets produce the vector \$FFFE–FFFF (\$FEFE–FEFF in monitor mode) and assert the internal reset signal (IRST). IRST causes all registers to be returned to their default values and all modules to be returned to their reset states.

An internal reset clears the SIM counter (see [14.4 SIM Counter](#)), but an external reset does not. Each of the resets sets a corresponding bit in the SIM reset status register (SRSR). See [14.7.2 SIM Reset Status Register](#).

14.3.1 External Pin Reset

Pulling the asynchronous \overline{RST} pin low halts all processing. The PIN bit of the SIM reset status register (SRSR) is set as long as \overline{RST} is held low for a minimum of 67 CGMXCLK cycles, assuming that neither the POR nor the LVI was the source of the reset. See [Table 14-2](#) for details. [Figure 14-3](#) shows the relative timing.

Table 14-2. PIN Bit Set Timing

Reset Type	Number of Cycles Required to Set PIN
POR/LVI	4163 (4096 + 64 + 3)
All others	67 (64 + 3)

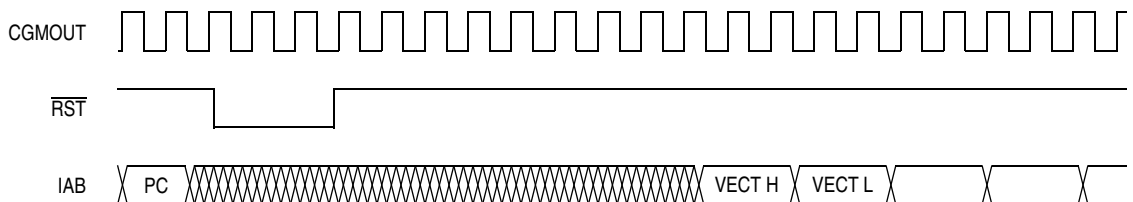

Figure 14-3. External Reset Timing

14.3.2 Active Resets from Internal Sources

All internal reset sources actively pull the \overline{RST} pin low for 32 CGMXCLK cycles to allow resetting of external peripherals. The internal reset signal (IRST) continues to be asserted for an additional 32 cycles (see Figure 14-5). An internal reset can be caused by an illegal address, illegal opcode, COP timeout, LVI, or POR. (See Figure 14-4.)

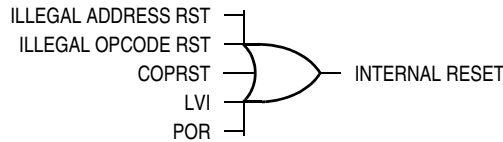

Figure 14-4. Sources of Internal Reset

NOTE: For LVI or POR resets, the SIM cycles through 4096 CGMXCLK cycles during which the SIM forces the \overline{RST} pin low. The internal reset signal then follows the sequence from the falling edge of \overline{RST} , as shown in Figure 14-5.

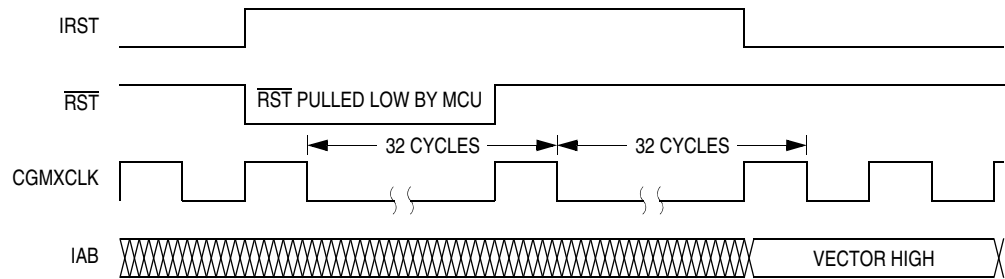

Figure 14-5. Internal Reset Timing

The COP reset is asynchronous to the bus clock.

The active reset feature allows the part to issue a reset to peripherals and other chips within a system built around the MCU.

14.3.2.1 Power-On Reset (POR)

When power is first applied to the MCU, the power-on reset (POR) module generates a pulse to indicate that power-on has occurred. The external reset pin (\overline{RST}) is held low while the SIM counter counts out 4096 CGMXCLK cycles. Sixty-four CGMXCLK cycles later, the CPU and memories are released from reset to allow the reset vector sequence to occur.

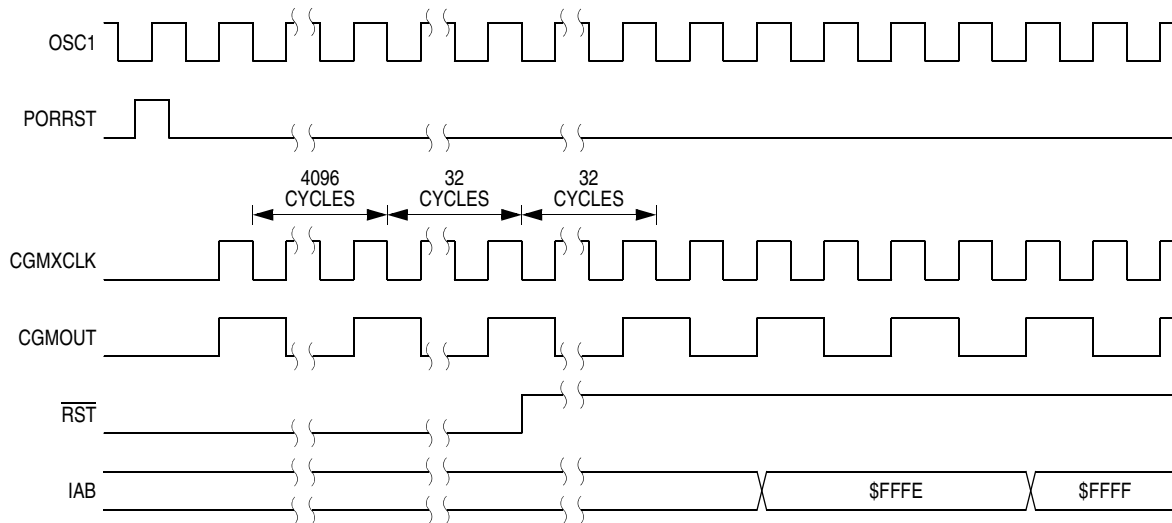

Figure 14-6. POR Recovery

At power-on, these events occur:

- A POR pulse is generated.
- The internal reset signal is asserted.
- The SIM enables CGMOUT.
- Internal clocks to the CPU and modules are held inactive for 4096 CGMXCLK cycles to allow stabilization of the oscillator.
- The \overline{RST} pin is driven low during the oscillator stabilization time.
- The POR bit of the SIM reset status register (SRSR) is set and all other bits in the register are cleared.

14.3.2.2 Computer Operating Properly (COP) Reset

An input to the SIM is reserved for the COP reset signal. The overflow of the COP counter causes an internal reset and sets the COP bit in the SIM reset status register (SRSR). The SIM actively pulls down the \overline{RST} pin for all internal reset sources.

To prevent a COP module timeout, write any value to location \$FFFE. Writing to location \$FFFF clears the COP counter and bits 12–4 of the SIM counter. The SIM counter output, which occurs at least every $2^{13}-2^4$ CGMXCLK cycles, drives the COP counter. The COP should be serviced as soon as possible out of reset to guarantee the maximum amount of time before the first timeout.

The COP module is disabled if the \overline{RST} pin or the \overline{IRQ} pin is held at V_{HI} while the MCU is in monitor mode. The COP module can be disabled only through combinational logic conditioned with the high voltage signal on the \overline{RST} or the \overline{IRQ}

pin. This prevents the COP from becoming disabled as a result of external noise. During a break state, V_{HI} on the \overline{RST} pin disables the COP module.

14.3.2.3 Illegal Opcode Reset

The SIM decodes signals from the CPU to detect illegal instructions. An illegal instruction sets the ILOP bit in the SIM reset status register (SRSR) and causes a reset.

Because the MC68HC908MR32 has stop mode disabled, execution of the STOP instruction will cause an illegal opcode reset.

14.3.2.4 Illegal Address Reset

An opcode fetch from addresses other than FLASH or RAM addresses generates an illegal address reset (unimplemented locations within memory map). The SIM verifies that the CPU is fetching an opcode prior to asserting the ILAD bit in the SIM reset status register (SRSR) and resetting the MCU. A data fetch from an unmapped address does not generate a reset.

14.3.2.5 Forced Monitor Mode Entry Reset (MENRST)

The MENRST module monitors the reset vector fetches and will assert an internal reset if it detects that the reset vectors are erased (\$FF). When the MCU comes out of reset, it is forced into monitor mode.

14.3.2.6 Low-Voltage Inhibit (LVI) Reset

The low-voltage inhibit (LVI) module asserts its output to the SIM when the V_{DD} voltage falls to the V_{LVRX} voltage and remains at or below that level for at least nine consecutive CPU cycles (see [19.5 DC Electrical Characteristics](#)). The LVI bit in the SIM reset status register (SRSR) is set, and the external reset pin (\overline{RST}) is held low while the SIM counter counts out 4096 CGMXCLK cycles. Sixty-four CGMXCLK cycles later, the CPU is released from reset to allow the reset vector sequence to occur. The SIM actively pulls down the \overline{RST} pin for all internal reset sources.

14.4 SIM Counter

The SIM counter is used by the power-on reset (POR) module to allow the oscillator time to stabilize before enabling the internal bus (IBUS) clocks. The SIM counter also serves as a prescaler for the computer operating properly (COP) module. The SIM counter overflow supplies the clock for the COP module. The SIM counter is 13 bits long and is clocked by the falling edge of CGMXCLK.

14.4.1 SIM Counter During Power-On Reset

The power-on reset (POR) module detects power applied to the MCU. At power-on, the POR circuit asserts the signal PORRST. Once the SIM is initialized, it enables the clock generation (CGM) module to drive the bus clock state machine.

14.4.2 SIM Counter and Reset States

External reset has no effect on the SIM counter. The SIM counter is free-running after all reset states. For counter control and internal reset recovery sequences, see [14.3.2 Active Resets from Internal Sources](#).

14.5 Exception Control

Normal, sequential program execution can be changed in three different ways:

1. Interrupts:
 - a. Maskable hardware CPU interrupts
 - b. Non-maskable software interrupt instruction (SWI)
2. Reset
3. Break interrupts

14.5.1 Interrupts

At the beginning of an interrupt, the CPU saves the CPU register contents on the stack and sets the interrupt mask (I bit) to prevent additional interrupts. At the end of an interrupt, the return-from-interrupt (RTI) instruction recovers the CPU register contents from the stack so that normal processing can resume. [Figure 14-7](#) shows interrupt entry timing. [Figure 14-9](#) shows interrupt recovery timing.

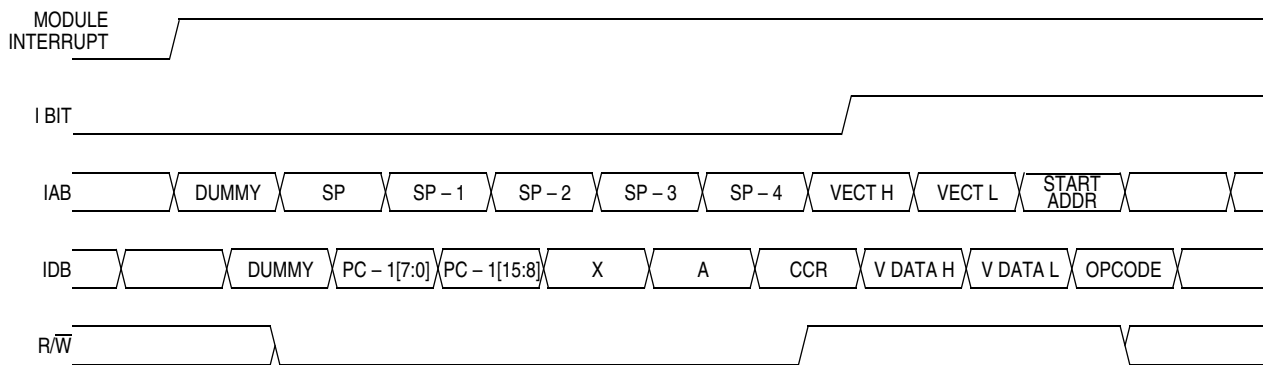

Figure 14-7. Interrupt Entry

Interrupts are latched, and arbitration is performed in the SIM at the start of interrupt processing. The arbitration result is a constant that the CPU uses to determine which vector to fetch. Once an interrupt is latched by the SIM, no other interrupt can take precedence, regardless of priority, until the latched interrupt is serviced (or the I bit is cleared). See [Figure 14-8](#).

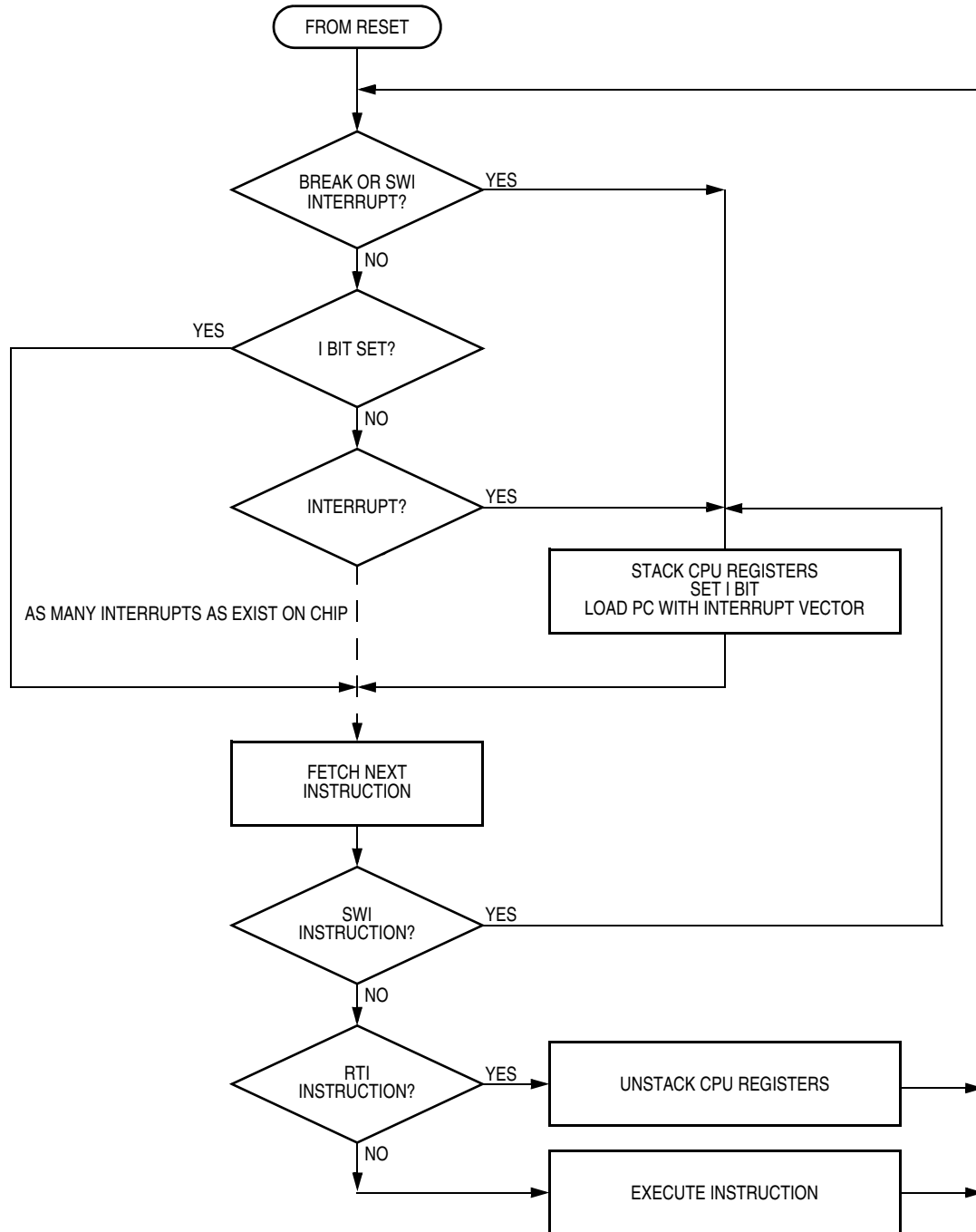

Figure 14-8. Interrupt Processing

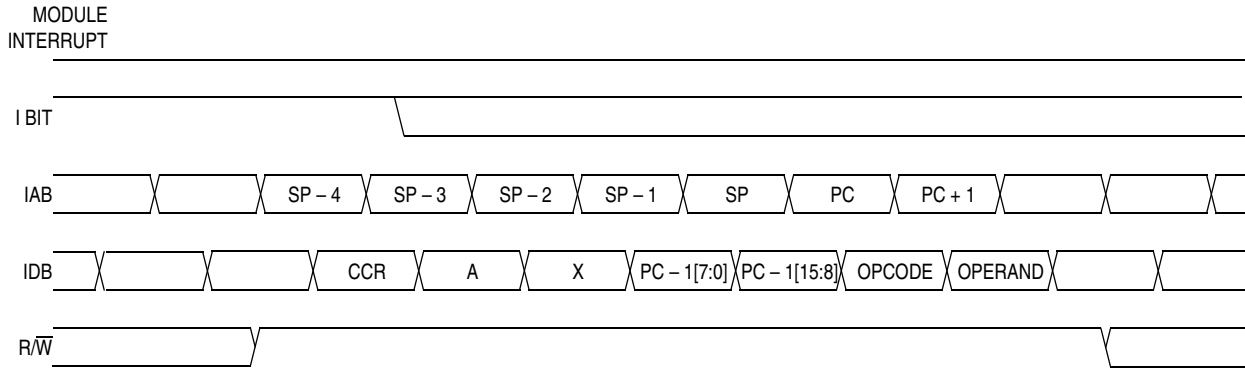

Figure 14-9. Interrupt Recovery

14.5.1.1 Hardware Interrupts

A hardware interrupt does not stop the current instruction. Processing of a hardware interrupt begins after completion of the current instruction. When the current instruction is complete, the SIM checks all pending hardware interrupts. If interrupts are not masked (I bit clear in the condition code register), and if the corresponding interrupt enable bit is set, the SIM proceeds with interrupt processing; otherwise, the next instruction is fetched and executed.

If more than one interrupt is pending at the end of an instruction execution, the highest priority interrupt is serviced first. Figure 14-10 demonstrates what happens when two interrupts are pending. If an interrupt is pending upon exit from the original interrupt service routine, the pending interrupt is serviced before the load-accumulator-from-memory (LDA) instruction is executed.

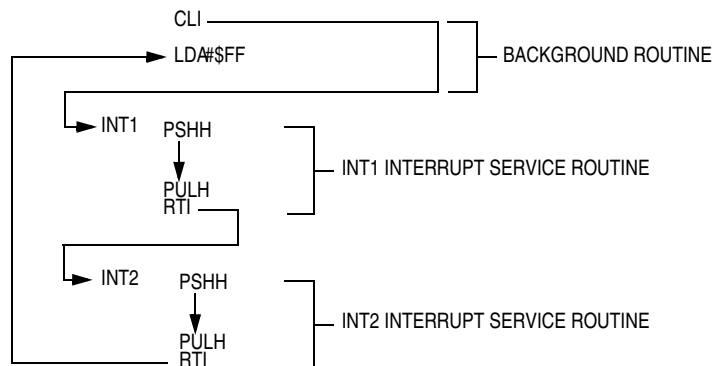

Figure 14-10. Interrupt Recognition Example

The LDA opcode is prefetched by both the INT1 and INT2 RTI instructions. However, in the case of the INT1 RTI prefetch, this is a redundant operation.

NOTE: To maintain compatibility with the M6805 Family, the H register is not pushed on the stack during interrupt entry. If the interrupt service routine modifies the H

register or uses the indexed addressing mode, software should save the H register and then restore it prior to exiting the routine.

14.5.1.2 Software Interrupt (SWI) Instruction

The software interrupt (SWI) instruction is a non-maskable instruction that causes an interrupt regardless of the state of the interrupt mask (I bit) in the condition code register.

14.5.2 Reset

All reset sources always have equal and highest priority and cannot be arbitrated.

14.6 Low-Power Mode

Executing the WAIT instruction puts the MCU in a low power-consumption mode for standby situations. The SIM holds the CPU in a non-clocked state. WAIT clears the interrupt mask (I) in the condition code register, allowing interrupts to occur.

14.6.1 Wait Mode

In wait mode, the CPU clocks are inactive while the peripheral clocks continue to run. **Figure 14-11** shows the timing for wait mode entry.

A module that is active during wait mode can wake up the CPU with an interrupt if the interrupt is enabled. Stacking for the interrupt begins one cycle after the WAIT instruction during which the interrupt occurred. Refer to the wait mode subsection of each module to see if the module is active or inactive in wait mode. Some modules can be programmed to be active in wait mode.

Wait mode can also be exited by a reset. If the COP disable bit, COPD, in the configuration register is logic 0, then the computer operating properly module (COP) is enabled and remains active in wait mode.

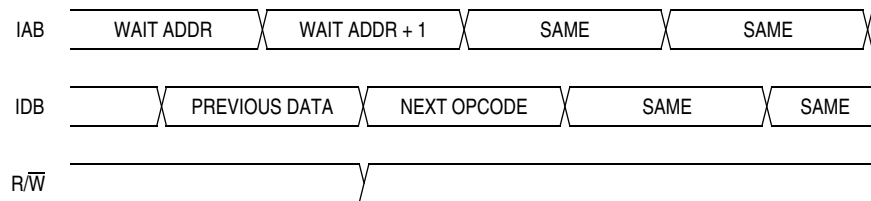

Note: Previous data can be operand data or the WAIT opcode, depending on the last instruction.

Figure 14-11. Wait Mode Entry Timing

Figure 14-12 and Figure 14-13 show the timing for wait recovery.

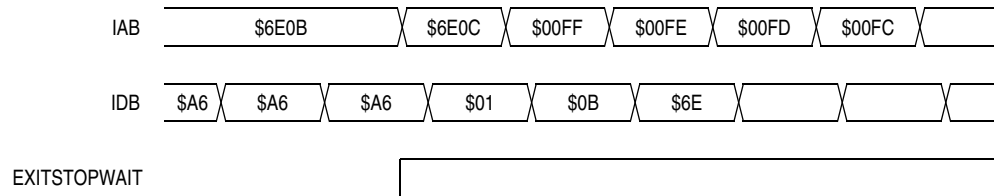

Note: EXITSTOPWAIT = $\overline{\text{RST}}$ pin OR CPU interrupt

Figure 14-12. Wait Recovery from Interrupt

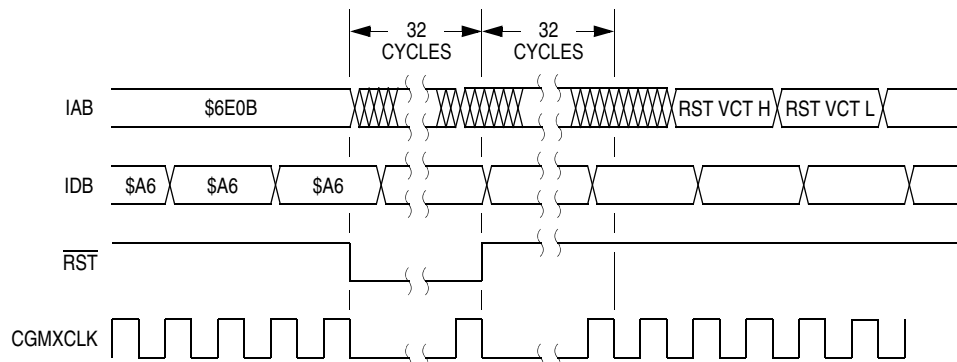

Figure 14-13. Wait Recovery from Internal Reset

14.6.2 Stop Mode

In stop mode, the SIM counter is reset and the system clocks are disabled. An interrupt request from a module can cause an exit from stop mode. Stacking for interrupts begins after the selected stop recovery time has elapsed. Reset or break also causes an exit from stop mode.

The SIM disables the clock generator module outputs (CGMOUT and CGMXCLK) in stop mode, stopping the CPU and peripherals. Stop recovery time is hard wired at the normal delay of 4096 CGMXCLK cycles.

It is important to note that when using the PWM generator, its outputs will stop toggling when stop mode is entered. The PWM module must be disabled before entering stop mode to prevent external inverter failure.

14.7 SIM Registers

This subsection describes the SIM registers.

14.7.1 SIM Break Status Register

The SIM break status register (SBSR) contains a flag to indicate that a break caused an exit from wait mode.

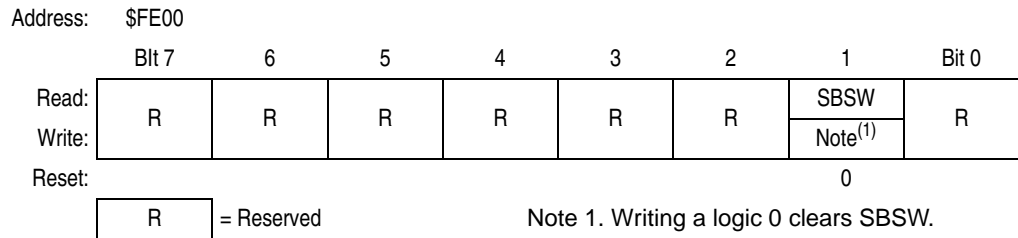

Figure 14-14. SIM Break Status Register (SBSR)

SBSW — SIM Break Stop/Wait

This status bit is useful in applications requiring a return to wait mode after exiting from a break interrupt. Clear SBSW by writing a logic 0 to it. Reset clears SBSW.

- 1 = Wait mode was exited by break interrupt.
- 0 = Wait mode was not exited by break interrupt.

SBSW can be read within the break state SWI routine. The user can modify the return address on the stack by subtracting one from it.

14.7.2 SIM Reset Status Register

The SIM reset status register (SRSR) contains six flags that show the source of the last reset. Clear the SIM reset status register by reading it. A power-on reset sets the POR bit and clears all other bits in the register.

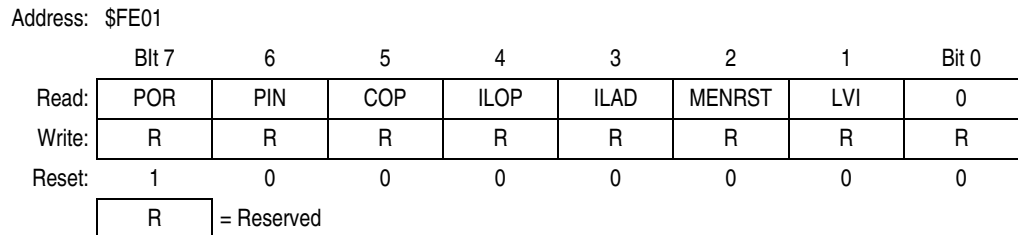

Figure 14-15. SIM Reset Status Register (SRSR)

POR — Power-On Reset Bit

- 1 = Last reset caused by POR circuit
- 0 = Read of SRSR

PIN — External Reset Bit

- 1 = Last reset caused by external reset pin (\overline{RST})
- 0 = POR or read of SRSR

- COP — Computer Operating Properly Reset Bit
1 = Last reset caused by COP counter
0 = POR or read of SRSR
- ILOP — Illegal Opcode Reset Bit
1 = Last reset caused by an illegal opcode
0 = POR or read of SRSR
- ILAD — Illegal Address Reset Bit (opcode fetches only)
1 = Last reset caused by an opcode fetch from an illegal address
0 = POR or read of SRSR
- MENRST — Forced Monitor Mode Entry Reset Bit
1 = Last reset caused by the MENRST circuit
0 = POR or read of SRSR
- LVI — Low-Voltage Inhibit Reset Bit
1 = Last reset caused by the LVI circuit
0 = POR or read of SRSR

14.7.3 SIM Break Flag Control Register

The SIM break control register (SBFCR) contains a bit that enables software to clear status bits while the MCU is in a break state.

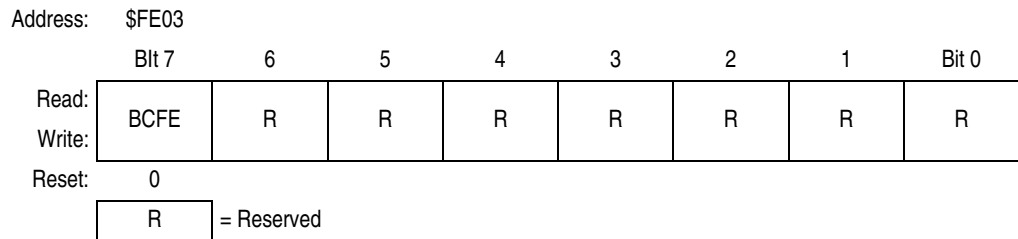

Figure 14-16. SIM Break Flag Control Register (SBFCR)

BCFE — Break Clear Flag Enable Bit

This read/write bit enables software to clear status bits by accessing status registers while the MCU is in a break state. To clear status bits during the break state, the BCFE bit must be set.

- 1 = Status bits clearable during break
- 0 = Status bits not clearable during break

Section 15. Serial Peripheral Interface Module (SPI)

15.1 Introduction

The serial peripheral interface (SPI) module allows full-duplex, synchronous, serial communications with peripheral devices.

15.2 Features

Features of the SPI module include:

- Full-duplex operation
- Master and slave modes
- Double-buffered operation with separate transmit and receive registers
- Four master mode frequencies (maximum = bus frequency \div 2)
- Maximum slave mode frequency = bus frequency
- Serial clock with programmable polarity and phase
- Two separately enabled interrupts with central processor unit (CPU) service:
 - SPRF (SPI receiver full)
 - SPTE (SPI transmitter empty)
- Mode fault error flag with CPU interrupt capability
- Overflow error flag with CPU interrupt capability
- Programmable wired-OR mode
- I²C (inter-integrated circuit) compatibility

Serial Peripheral Interface Module (SPI)

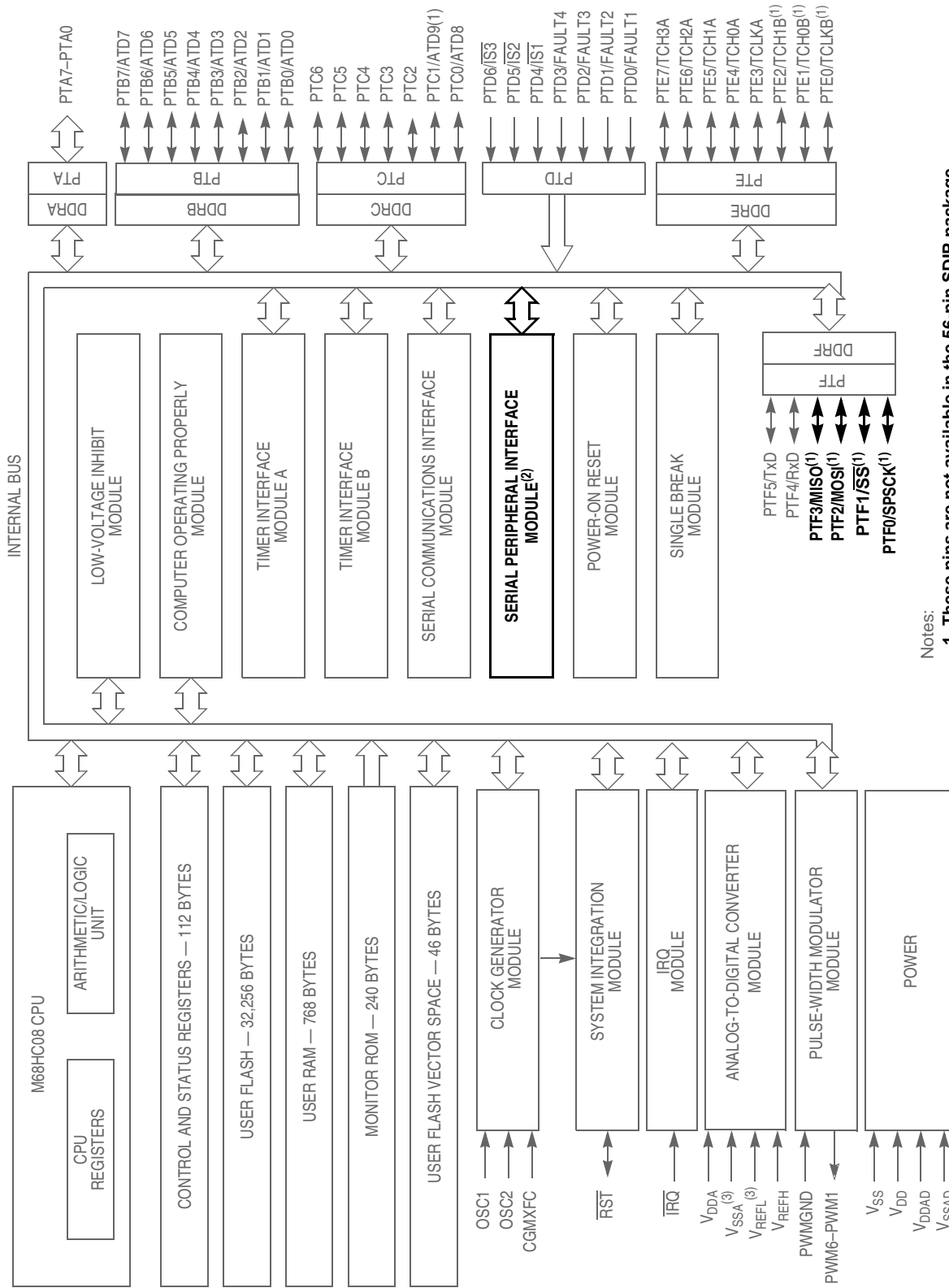

- Notes:
1. These pins are not available in the 56-pin SDIP package.
 2. This module is not available in the 56-pin SDIP package.
 3. In the 56-pin SDIP package, these pins are bonded together.

Figure 15-1. Block Diagram Highlighting SPI Block and Pins

15.3 Pin Name Conventions

The generic names of the SPI input/output (I/O) pins are:

- \overline{SS} , slave select
- SPCK, SPI serial clock
- MOSI, master out/slave in
- MISO, master in/slave out

SPI pins are shared by parallel I/O ports or have alternate functions. The full name of an SPI pin reflects the name of the shared port pin or the name of an alternate pin function. The generic pin names appear in the text that follows. [Table 15-1](#) shows the full names of the SPI I/O pins.

Table 15-1. Pin Name Conventions

Generic Pin Names:	MISO	MOSI	SPCK	\overline{SS}
Full Pin Names:	PTF3/MISO	PTF2/MOSI	PTF0/SPCK	PTF1/ \overline{SS}

15.4 Functional Description

[Figure 15-3](#) shows the structure of the SPI module and [Figure 15-2](#) shows the locations and contents of the SPI I/O registers.

The SPI module allows full-duplex, synchronous, serial communication between the microcontroller unit (MCU) and peripheral devices, including other MCUs. Software can poll the SPI status flags or SPI operation can be interrupt-driven. All SPI interrupts can be serviced by the CPU.

Addr.	Register Name		Bit 7	6	5	4	3	2	1	Bit 0
\$0044	SPI Control Register (SPCR) See page 228.	Read:	SPRIE	R	SPMSTR	CPOL	CPHA	SPWOM	SPE	SPTIE
		Write:								
		Reset:	0	0	1	0	1	0	0	0
\$0045	SPI Status and Control Register (SPSCR) See page 229.	Read:	SPRF	ERRIE	OVRF	MODF	SPTIE	MODFEN	SPR1	SPR0
		Write:	R		R	R				
		Reset:	0	0	0	0	1	0	0	0
\$0046	SPI Data Register (SPDR) See page 232.	Read:	R7	R6	R5	R4	R3	R2	R1	R0
		Write:	T7	T6	T5	T4	T3	T2	T1	T0
		Reset:	Unaffected by reset							

R = Reserved

Figure 15-2. SPI I/O Register Summary

Serial Peripheral Interface Module (SPI)

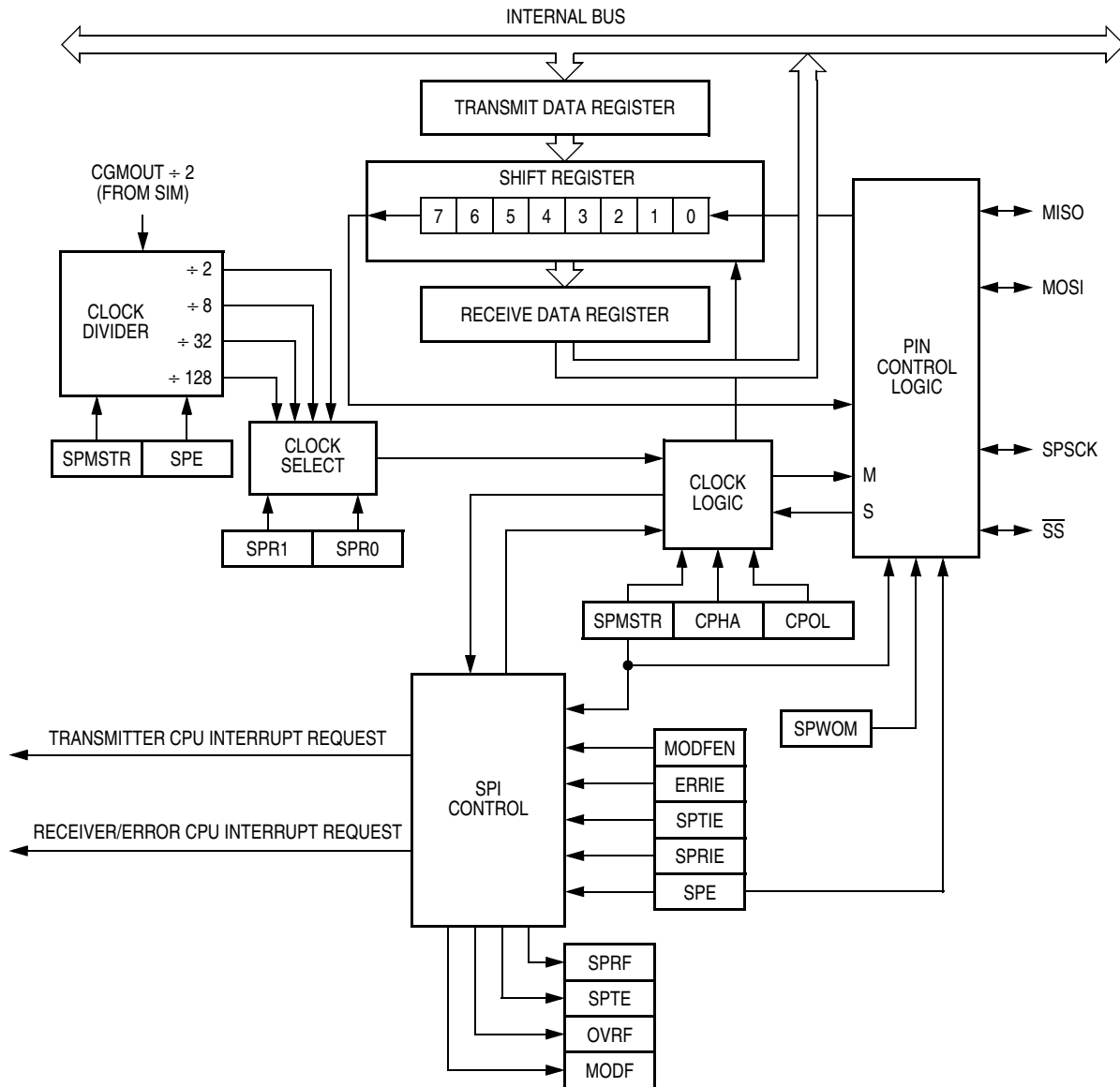

Figure 15-3. SPI Module Block Diagram

Freescale Semiconductor, Inc.

15.4.1 Master Mode

The SPI operates in master mode when the SPI master bit, SPMSTR, is set.

NOTE: *Configure the SPI modules as master or slave before enabling them. Enable the master SPI before enabling the slave SPI. Disable the slave SPI before disabling the master SPI. See [15.12.1 SPI Control Register](#).*

Only a master SPI module can initiate transmissions. Software begins the transmission from a master SPI module by writing to the SPI data register. If the shift register is empty, the byte immediately transfers to the shift register, setting the SPI transmitter empty bit, SPTE. The byte begins shifting out on the MOSI pin under the control of the serial clock. See [Figure 15-4](#).

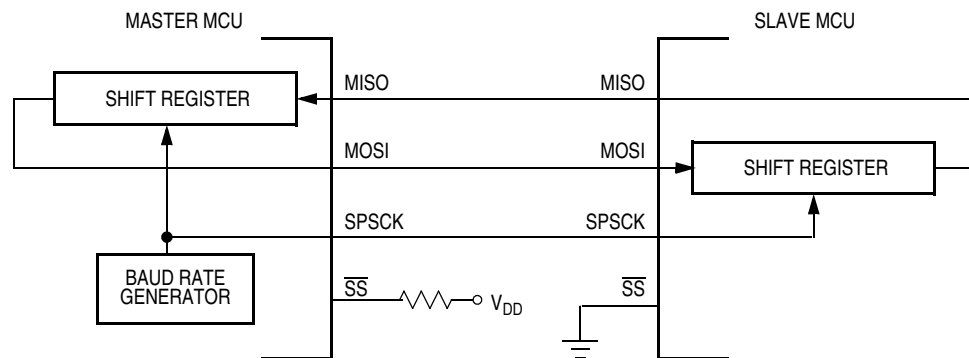

Figure 15-4. Full-Duplex Master-Slave Connections

The SPR1 and SPR0 bits control the baud rate generator and determine the speed of the shift register. See [15.12.2 SPI Status and Control Register](#). Through the SPSCK pin, the baud-rate generator of the master also controls the shift register of the slave peripheral.

As the byte shifts out on the MOSI pin of the master, another byte shifts in from the slave on the master's MISO pin. The transmission ends when the receiver full bit, SPRF, becomes set. At the same time that SPRF becomes set, the byte from the slave transfers to the receive data register. In normal operation, SPRF signals the end of a transmission. Software clears SPRF by reading the SPI status and control register with SPRF set and then reading the SPI data register. Writing to the SPI data register clears the SPTE bit.

15.4.2 Slave Mode

The SPI operates in slave mode when the SPMSTR bit is clear. In slave mode the SPSCK pin is the input for the serial clock from the master MCU. Before a data transmission occurs, the \overline{SS} pin of the slave SPI must be at logic 0. \overline{SS} must remain low until the transmission is complete. See [15.6.2 Mode Fault Error](#).

In a slave SPI module, data enters the shift register under the control of the serial clock from the master SPI module. After a byte enters the shift register of a slave SPI, it transfers to the receive data register, and the SPRF bit is set. To prevent an overflow condition, slave software then must read the receive data register before another full byte enters the shift register.

The maximum frequency of the SPSCCK for an SPI configured as a slave is the bus clock speed (which is twice as fast as the fastest master SPSCCK clock that can be generated). The frequency of the SPSCCK for an SPI configured as a slave does not have to correspond to any SPI baud rate. The baud rate only controls the speed of the SPSCCK generated by an SPI configured as a master. Therefore, the frequency of the SPSCCK for an SPI configured as a slave can be any frequency less than or equal to the bus speed.

When the master SPI starts a transmission, the data in the slave shift register begins shifting out on the MISO pin. The slave can load its shift register with a new byte for the next transmission by writing to its transmit data register. The slave must write to its transmit data register at least one bus cycle before the master starts the next transmission. Otherwise, the byte already in the slave shift register shifts out on the MISO pin. Data written to the slave shift register during a transmission remains in a buffer until the end of the transmission.

When the clock phase bit (CPHA) is set, the first edge of SPSCCK starts a transmission. When CPHA is clear, the falling edge of \overline{SS} starts a transmission. See [15.5 Transmission Formats](#).

NOTE: *If the write to the data register is late, the SPI transmits the data already in the shift register from the previous transmission.*

SPSCCK must be in the proper idle state before the slave is enabled to prevent SPSCCK from appearing as a clock edge.

15.5 Transmission Formats

During an SPI transmission, data is simultaneously transmitted (shifted out serially) and received (shifted in serially). A serial clock synchronizes shifting and sampling on the two serial data lines. A slave select line allows selection of an individual slave SPI device; slave devices that are not selected do not interfere with SPI bus activities. On a master SPI device, the slave select line can optionally be used to indicate multiple-master bus contention.

15.5.1 Clock Phase and Polarity Controls

Software can select any of four combinations of serial clock (SPSCCK) phase and polarity using two bits in the SPI control register (SPCR). The clock polarity is specified by the CPOL control bit, which selects an active high or low clock and has no significant effect on the transmission format.

The clock phase (CPHA) control bit selects one of two fundamentally different transmission formats. The clock phase and polarity should be identical for the master SPI device and the communicating slave device. In some cases, the phase and polarity are changed between transmissions to allow a master device to communicate with peripheral slaves having different requirements.

NOTE: Before writing to the CPOL bit or the CPHA bit, disable the SPI by clearing the SPI enable bit (SPE).

15.5.2 Transmission Format When CPHA = 0

Figure 15-5 shows an SPI transmission in which CPHA is logic 0. The figure should not be used as a replacement for data sheet parametric information. Two waveforms are shown for SPSCCK: one for CPOL = 0 and another for CPOL = 1. The diagram may be interpreted as a master or slave timing diagram since the serial clock (SPSCCK), master in/slave out (MISO), and master out/slave in (MOSI) pins are directly connected between the master and the slave. The MISO signal is the output from the slave, and the MOSI signal is the output from the master. The SS line is the slave select input to the slave. The slave SPI drives its MISO output only when its slave select input (SS) is at logic 0, so that only the selected slave drives to the master. The SS pin of the master is not shown but is assumed to be inactive. The SS pin of the master must be high or must be reconfigured as general-purpose I/O not affecting the SPI. (See 15.6.2 Mode Fault Error.) When CPHA = 0, the first SPSCCK edge is the MSB capture strobe. Therefore, the slave must begin driving its data before the first SPSCCK edge, and a falling edge on the SS pin is used to start the slave data transmission. The slave's SS pin must be toggled back to high and then low again between each byte transmitted as shown in Figure 15-6.

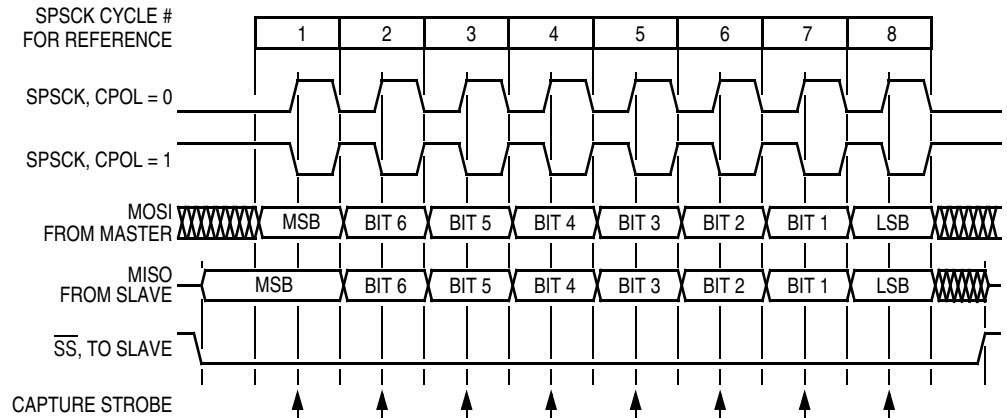

Figure 15-5. Transmission Format (CPHA = 0)

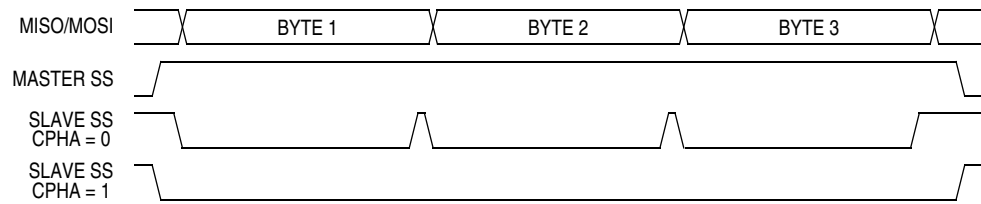

Figure 15-6. CPHA/ \overline{SS} Timing

When CPHA = 0 for a slave, the falling edge of \overline{SS} indicates the beginning of the transmission. This causes the SPI to leave its idle state and begin driving the MISO pin with the MSB of its data. Once the transmission begins, no new data is allowed into the shift register from the transmit data register. Therefore, the SPI data register of the slave must be loaded with transmit data before the falling edge of \overline{SS} . Any data written after the falling edge is stored in the transmit data register and transferred to the shift register after the current transmission.

15.5.3 Transmission Format When CPHA = 1

Figure 15-7 shows an SPI transmission in which CPHA is logic 1. The figure should not be used as a replacement for data sheet parametric information. Two waveforms are shown for SPSCCK: one for CPOL = 0 and another for CPOL = 1. The diagram may be interpreted as a master or slave timing diagram since the serial clock (SPSCCK), master in/slave out (MISO), and master out/slave in (MOSI) pins are directly connected between the master and the slave. The MISO signal is the output from the slave, and the MOSI signal is the output from the master. The \overline{SS} line is the slave select input to the slave. The slave SPI drives its MISO output only when its slave select input (\overline{SS}) is at logic 0, so that only the selected slave drives to the master. The \overline{SS} pin of the master is not shown but is assumed to be inactive. The \overline{SS} pin of the master must be high or must be reconfigured as general-purpose I/O not affecting the SPI. See 15.6.2 Mode Fault Error. When CPHA = 1, the master begins driving its MOSI pin on the first SPSCCK edge. Therefore, the slave uses the first SPSCCK edge as a start transmission signal. The \overline{SS} pin can remain low between transmissions. This format may be preferable in systems having only one master and only one slave driving the MISO data line.

When CPHA = 1 for a slave, the first edge of the SPSCCK indicates the beginning of the transmission. This causes the SPI to leave its idle state and begin driving the MISO pin with the MSB of its data. Once the transmission begins, no new data is allowed into the shift register from the transmit data register. Therefore, the SPI data register of the slave must be loaded with transmit data before the first edge of SPSCCK. Any data written after the first edge is stored in the transmit data register and transferred to the shift register after the current transmission.

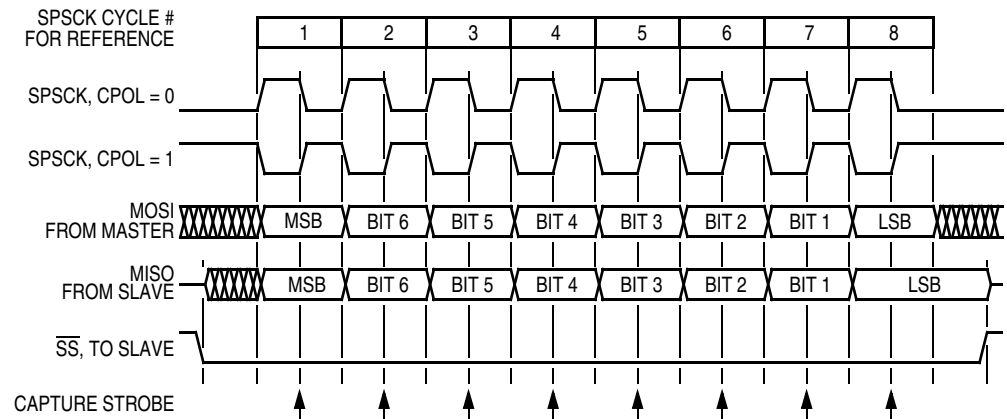

Figure 15-7. Transmission Format (CPHA = 1)

15.5.4 Transmission Initiation Latency

When the SPI is configured as a master (SPMSTR = 1), writing to the SPDR starts a transmission. CPHA has no effect on the delay to the start of the transmission, but it does affect the initial state of the SPSCK signal. When CPHA = 0, the SPSCK signal remains inactive for the first half of the first SPSCK cycle. When CPHA = 1, the first SPSCK cycle begins with an edge on the SPSCK line from its inactive to its active level. The SPI clock rate (selected by SPR1:SPR0) affects the delay from the write to SPDR and the start of the SPI transmission. See

Figure 15-8 The internal SPI clock in the master is a free-running derivative of the internal MCU clock. To conserve power, it is enabled only when both the SPE and SPMSTR bits are set. SPSCK edges occur halfway through the low time of the internal MCU clock. Since the SPI clock is free-running, it is uncertain where the write to the SPDR occurs relative to the slower SPSCK. This uncertainty causes the variation in the initiation delay shown in **Figure 15-8**. This delay is no longer than a single SPI bit time. That is, the maximum delay is two MCU bus cycles for DIV2, eight MCU bus cycles for DIV8, 32 MCU bus cycles for DIV32, and 128 MCU bus cycles for DIV128.

15.6 Error Conditions

These flags signal SPI error conditions:

- Overflow (OVRF) — Failing to read the SPI data register before the next full byte enters the shift register sets the OVRF bit. The new byte does not transfer to the receive data register, and the unread byte still can be read. OVRF is in the SPI status and control register.
- Mode fault error (MODF) — The MODF bit indicates that the voltage on the slave select pin (\overline{SS}) is inconsistent with the mode of the SPI. MODF is in the SPI status and control register.

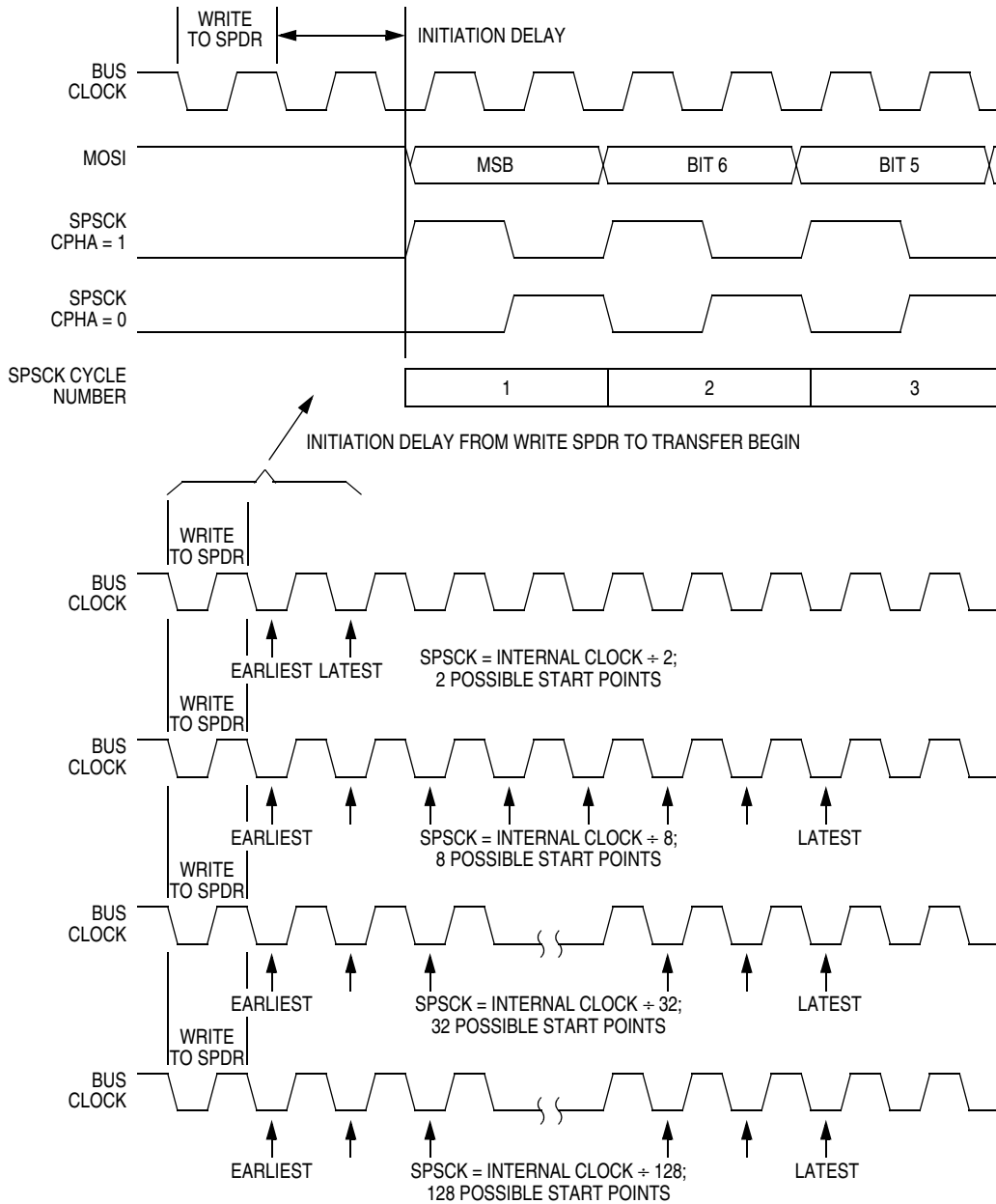

Figure 15-8. Transmission Start Delay (Master)

15.6.1 Overflow Error

The overflow flag (OVRF) becomes set if the receive data register still has unread data from a previous transmission when the capture strobe of bit 1 of the next transmission occurs. If an overflow occurs, all data received after the overflow and before the OVRF bit is cleared does not transfer to the receive data register and does not set the SPI receiver full bit (SPRF). The unread data that transferred to the receive data register before the overflow occurred can still be read. Therefore,

an overflow error always indicates the loss of data. Clear the overflow flag by reading the SPI status and control register and then reading the SPI data register.

OVRF generates a receiver/error CPU interrupt request if the error interrupt enable bit (ERRIE) is also set. MODF and OVRF can generate a receiver/error CPU interrupt request. See **Figure 15-11**. It is not possible to enable MODF or OVRF individually to generate a receiver/error CPU interrupt request. However, leaving MODFEN low prevents MODF from being set.

If the CPU SPRF interrupt is enabled and the OVRF interrupt is not, watch for an overflow condition. **Figure 15-9** shows how it is possible to miss an overflow. The first part of **Figure 15-9** shows how it is possible to read the SPSCR and SPDR to clear the SPRF without problems. However, as illustrated by the second transmission example, the OVRF bit can be set in between the time that SPSCR and SPDR are read.

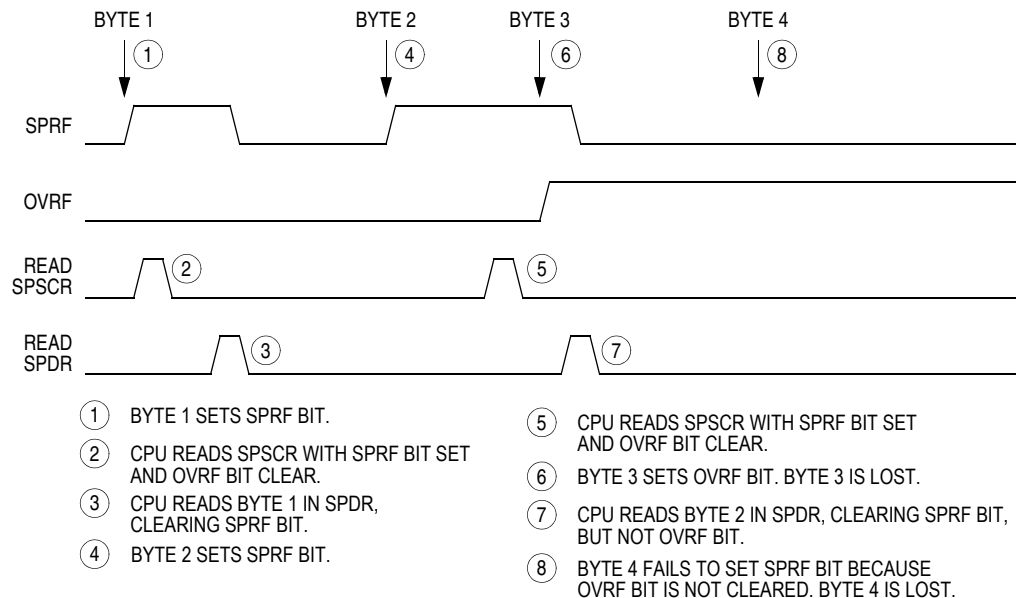

Figure 15-9. Missed Read of Overflow Condition

In this case, an overflow can easily be missed. Since no more SPRF interrupts can be generated until this OVRF is serviced, it is not obvious that bytes are being lost as more transmissions are completed. To prevent this, either enable the OVRF interrupt or do another read of the SPSCR following the read of the SPDR. This ensures that the OVRF was not set before the SPRF was cleared and that future transmissions can set the SPRF bit. **Figure 15-10** illustrates this process. Generally, to avoid this second SPSCR read, enable the OVRF interrupt to the CPU by setting the ERRIE bit.

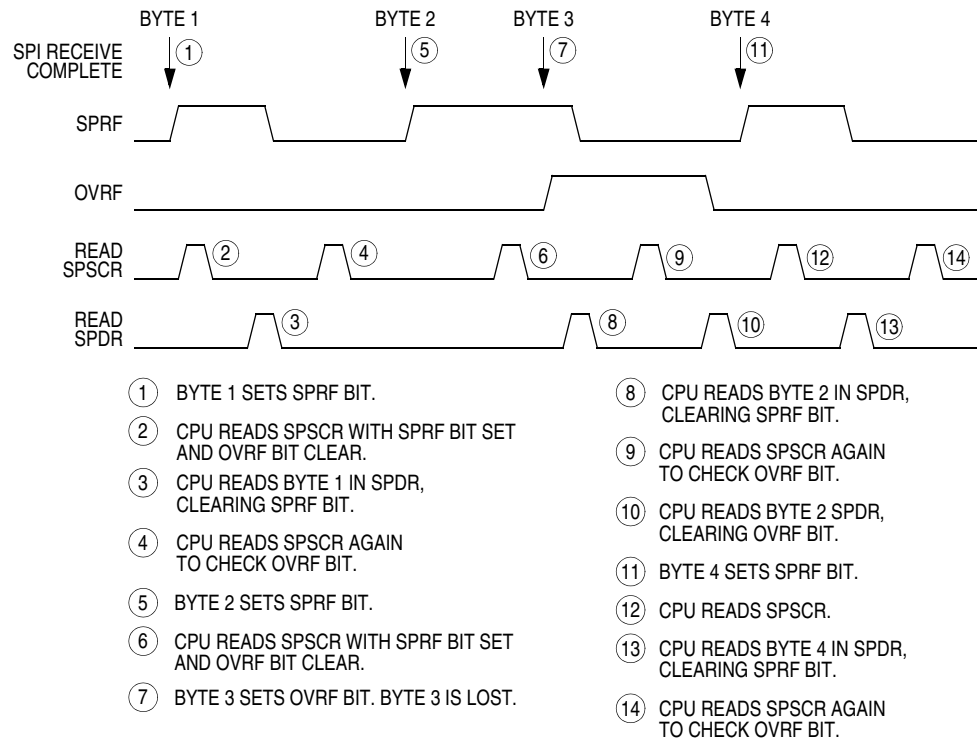

Figure 15-10. Clearing SPRF When OVRF Interrupt Is Not Enabled

15.6.2 Mode Fault Error

Setting the SPMSTR bit selects master mode and configures the SPSCCK and MOSI pins as outputs and the MISO pin as an input. Clearing SPMSTR selects slave mode and configures the SPSCCK and MOSI pins as inputs and the MISO pin as an output. The mode fault bit, MODF, becomes set any time the state of the slave select pin, \overline{SS} , is inconsistent with the mode selected by SPMSTR.

To prevent SPI pin contention and damage to the MCU, a mode fault error occurs if:

- The \overline{SS} pin of a slave SPI goes high during a transmission.
- The \overline{SS} pin of a master SPI goes low at any time.

For the MODF flag to be set, the mode fault error enable bit (MODFEN) must be set. Clearing the MODFEN bit does not clear the MODF flag but does prevent MODF from being set again after MODF is cleared.

MODF generates a receiver/error CPU interrupt request if the error interrupt enable bit (ERRIE) is also set. The SPRF, MODF, and OVRF interrupts share the same CPU interrupt vector. MODF and OVRF can generate a receiver/error CPU interrupt request. See Figure 15-11. It is not possible to enable MODF or OVRF individually to generate a receiver/error CPU interrupt request. However, leaving MODFEN low prevents MODF from being set.

In a master SPI with the mode fault enable bit (MODFEN) set, the mode fault flag (MODF) is set if \overline{SS} goes to logic 0. A mode fault in a master SPI causes these events to occur:

- If ERRIE = 1, the SPI generates an SPI receiver/error CPU interrupt request.
- The SPE bit is cleared.
- The SPTE bit is set.
- The SPI state counter is cleared.
- The data direction register of the shared I/O port regains control of port drivers.

NOTE: *To prevent bus contention with another master SPI after a mode fault error, clear all SPI bits of the data direction register of the shared I/O port before enabling the SPI.*

When configured as a slave (SPMSTR = 0), the MODF flag is set if \overline{SS} goes high during a transmission. When CPHA = 0, a transmission begins when \overline{SS} goes low and ends once the incoming SPSCCK goes back to its idle level following the shift of the eighth data bit. When CPHA = 1, the transmission begins when the SPSCCK leaves its idle level and \overline{SS} is already low. The transmission continues until the SPSCCK returns to its idle level following the shift of the last data bit. See [15.5 Transmission Formats](#).

NOTE: *Setting the MODF flag does not clear the SPMSTR bit. Reading SPMSTR when MODF = 1 will indicate a mode fault error occurred in either master mode or slave mode.*

When CPHA = 0, a MODF occurs if a slave is selected (\overline{SS} is at logic 0) and later unselected (\overline{SS} is at logic 1) even if no SPSCCK is sent to that slave. This happens because \overline{SS} at logic 0 indicates the start of the transmission (MISO driven out with the value of MSB) for CPHA = 0. When CPHA = 1, a slave can be selected and then later unselected with no transmission occurring. Therefore, MODF does not occur since a transmission was never begun.

In a slave SPI (MSTR = 0), the MODF bit generates an SPI receiver/error CPU interrupt request if the ERRIE bit is set. The MODF bit does not clear the SPE bit or reset the SPI in any way. Software can abort the SPI transmission by clearing the SPE bit of the slave.

NOTE: *A logic 1 voltage on the \overline{SS} pin of a slave SPI puts the MISO pin in a high impedance state. Also, the slave SPI ignores all incoming SPSCCK clocks, even if it was already in the middle of a transmission.*

To clear the MODF flag, read the SPSCR with the MODF bit set and then write to the SPCR register. This entire clearing procedure must occur with no MODF condition existing or else the flag is not cleared.

15.7 Interrupts

Four SPI status flags can be enabled to generate CPU interrupt requests as shown in [Table 15-2](#).

Table 15-2. SPI Interrupts

Flag	Request
SPTE transmitter empty	SPI transmitter CPU interrupt request (SPTIE = 1, SPE = 1)
SPRF receiver full	SPI receiver CPU interrupt request (SPRIE = 1)
OVRF overflow	SPI receiver/error interrupt request (ERRIE = 1)
MODF mode fault	SPI receiver/error interrupt request (ERRIE = 1)

The SPI transmitter interrupt enable bit (SPTIE) enables the SPTE flag to generate transmitter CPU interrupt requests, provided that the SPI is enabled (SPE = 1).

The SPI receiver interrupt enable bit (SPRIE) enables the SPRF bit to generate receiver CPU interrupt requests, provided that the SPI is enabled (SPE = 1). (See [Figure 15-11](#).)

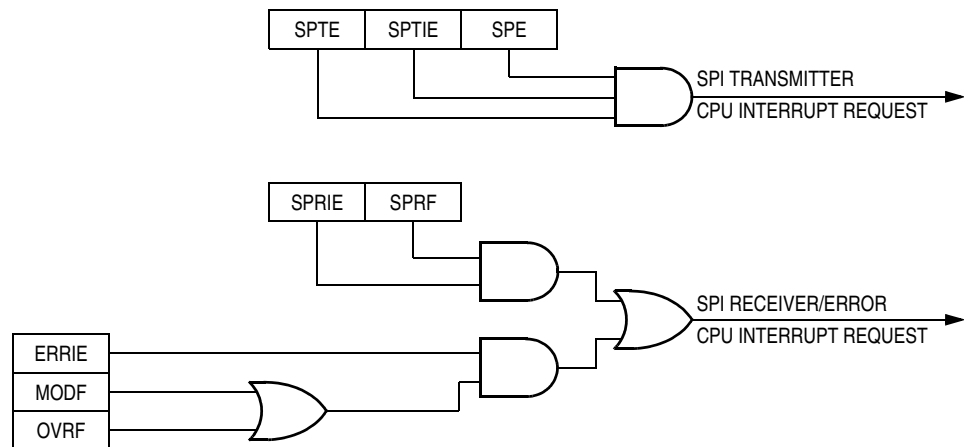

Figure 15-11. SPI Interrupt Request Generation

The error interrupt enable bit (ERRIE) enables both the MODF and OVRF bits to generate a receiver/error CPU interrupt request.

The mode fault enable bit (MODFEN) can prevent the MODF flag from being set so that only the OVRF bit is enabled by the ERRIE bit to generate receiver/error CPU interrupt requests.

These sources in the SPI status and control register can generate CPU interrupt requests:

- SPI receiver full bit (SPRF) — The SPRF bit becomes set every time a byte transfers from the shift register to the receive data register. If the SPI receiver interrupt enable bit, SPRIE, is also set, SPRF can generate either an SPI receiver/error or CPU interrupt.
- SPI transmitter empty (SPTE) — The SPTE bit becomes set every time a byte transfers from the transmit data register to the shift register. If the SPI transmit interrupt enable bit, SPTIE, is also set, SPTE can generate either an SPTE or CPU interrupt request.

15.8 Resetting the SPI

Any system reset completely resets the SPI. Partial resets occur whenever the SPI enable bit (SPE) is low. Whenever SPE is low:

- The SPTE flag is set.
- Any transmission currently in progress is aborted.
- The shift register is cleared.
- The SPI state counter is cleared, making it ready for a new complete transmission.
- All the SPI port logic is defaulted back to being general-purpose I/O.

These items are reset only by a system reset:

- All control bits in the SPCR
- All control bits in the SPSCR (MODFEN, ERRIE, SPR1, and SPR0)
- The status flags SPRF, OVRF, and MODF

By not resetting the control bits when SPE is low, the user can clear SPE between transmissions without having to set all control bits again when SPE is set back high for the next transmission.

By not resetting the SPRF, OVRF, and MODF flags, the user can still service these interrupts after the SPI has been disabled. The user can disable the SPI by writing 0 to the SPE bit. The SPI can also be disabled by a mode fault occurring in an SPI that was configured as a master with the MODFEN bit set.

15.9 Queuing Transmission Data

The double-buffered transmit data register allows a data byte to be queued and transmitted. For an SPI configured as a master, a queued data byte is transmitted immediately after the previous transmission has completed. The SPI transmitter empty flag (SPTE) indicates when the transmit data buffer is ready to accept new data. Write to the transmit data register only when the SPTE bit is high.

Figure 15-12 shows the timing associated with doing back-to-back transmissions with the SPI (SPSCK has CPHA:CPOL = 1:0).

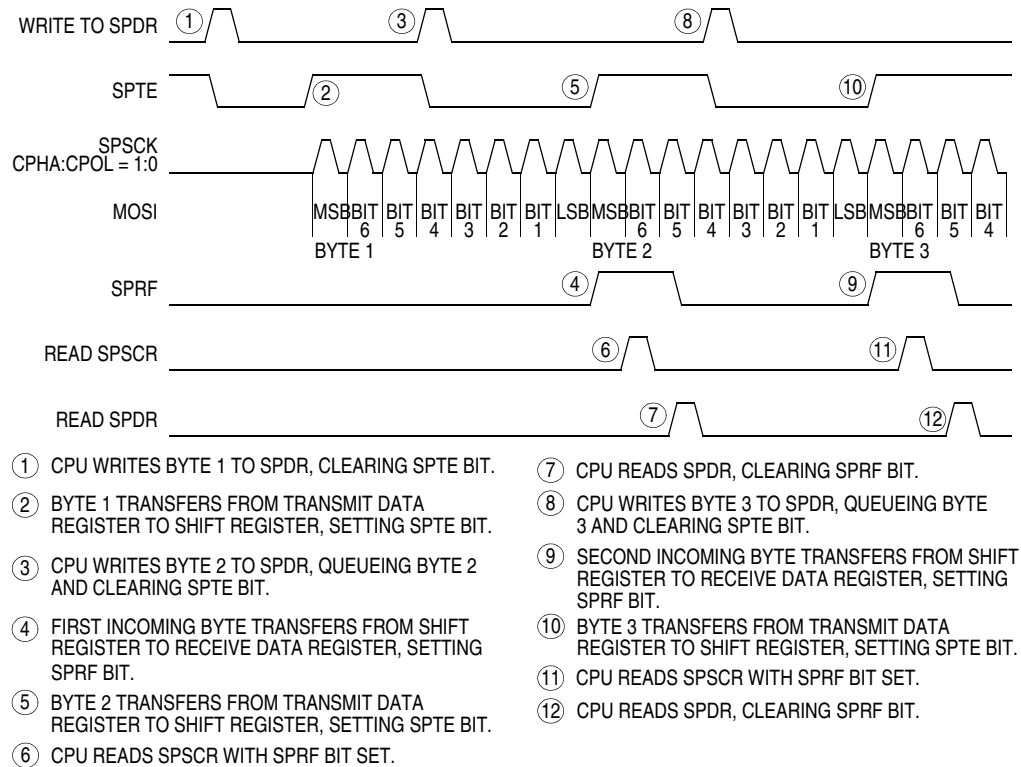

Figure 15-12. SPRF/SPTE CPU Interrupt Timing

For a slave, the transmit data buffer allows back-to-back transmissions without the slave precisely timing its writes between transmissions as in a system with a single data buffer. Also, if no new data is written to the data buffer, the last value contained in the shift register is the next data word to be transmitted.

For an idle master or idle slave that has no data loaded into its transmit buffer, the SPTE is set again no more than two bus cycles after the transmit buffer empties into the shift register. This allows the user to queue up a 16-bit value to send. For an already active slave, the load of the shift register cannot occur until the transmission is completed. This implies that a back-to-back write to the transmit data register is not possible. The SPTE indicates when the next write can occur.

15.10 Low-Power Mode

The WAIT instruction puts the MCU in a low power-consumption standby mode.

The SPI module remains active after the execution of a WAIT instruction. In wait mode the SPI module registers are not accessible by the CPU. Any enabled CPU interrupt request from the SPI module can bring the MCU out of wait mode.

If SPI module functions are not required during wait mode, reduce power consumption by disabling the SPI module before executing the WAIT instruction.

To exit wait mode when an overflow condition occurs, enable the OVRF bit to generate CPU interrupt requests by setting the error interrupt enable bit (ERRIE). See [15.7 Interrupts](#).

Since the SPTE bit cannot be cleared during a break with the BCFE bit cleared, a write to the transmit data register in break mode does not initiate a transmission nor is this data transferred into the shift register. Therefore, a write to the SPDR in break mode with the BCFE bit cleared has no effect.

15.11 I/O Signals

The SPI module has five I/O pins and shares four of them with a parallel I/O port. The pins are:

- MISO — Data received
- MOSI — Data transmitted
- SPCK — Serial clock
- \overline{SS} — Slave select

The SPI has limited inter-integrated circuit (I²C) capability (requiring software support) as a master in a single-master environment. To communicate with I²C peripherals, MOSI becomes an open-drain output when the SPWOM bit in the SPI control register is set. In I²C communication, the MOSI and MISO pins are connected to a bidirectional pin from the I²C peripheral and through a pullup resistor to V_{DD}.

15.11.1 MISO (Master In/Slave Out)

MISO is one of the two SPI module pins that transmits serial data. In full duplex operation, the MISO pin of the master SPI module is connected to the MISO pin of the slave SPI module. The master SPI simultaneously receives data on its MISO pin and transmits data from its MOSI pin.

Slave output data on the MISO pin is enabled only when the SPI is configured as a slave. The SPI is configured as a slave when its SPMSTR bit is logic 0 and its \overline{SS} pin is at logic 0. To support a multiple-slave system, a logic 1 on the \overline{SS} pin puts the MISO pin in a high-impedance state.

When enabled, the SPI controls data direction of the MISO pin regardless of the state of the data direction register of the shared I/O port.

15.11.2 MOSI (Master Out/Slave In)

MOSI is one of the two SPI module pins that transmits serial data. In full-duplex operation, the MOSI pin of the master SPI module is connected to the MOSI pin of the slave SPI module. The master SPI simultaneously transmits data from its MOSI pin and receives data on its MISO pin.

When enabled, the SPI controls data direction of the MOSI pin regardless of the state of the data direction register of the shared I/O port.

15.11.3 SPSCCK (Serial Clock)

The serial clock synchronizes data transmission between master and slave devices. In a master MCU, the SPSCCK pin is the clock output. In a slave MCU, the SPSCCK pin is the clock input. In full-duplex operation, the master and slave MCUs exchange a byte of data in eight serial clock cycles.

When enabled, the SPI controls data direction of the SPSCCK pin regardless of the state of the data direction register of the shared I/O port.

15.11.4 \overline{SS} (Slave Select)

The \overline{SS} pin has various functions depending on the current state of the SPI. For an SPI configured as a slave, the \overline{SS} is used to select a slave. For CPHA = 0, the \overline{SS} is used to define the start of a transmission. See [15.5 Transmission Formats](#). Since it is used to indicate the start of a transmission, the \overline{SS} must be toggled high and low between each byte transmitted for the CPHA = 0 format. However, it can remain low between transmissions for the CPHA = 1 format. See [Figure 15-13](#).

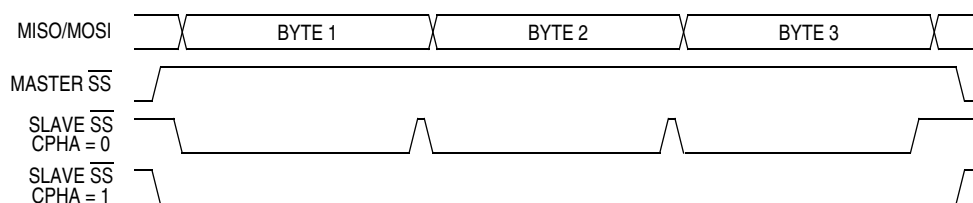

Figure 15-13. CPHA/ \overline{SS} Timing

When an SPI is configured as a slave, the \overline{SS} pin is always configured as an input. It cannot be used as a general-purpose I/O regardless of the state of the MODFEN control bit. However, the MODFEN bit can still prevent the state of the \overline{SS} from creating a MODF error. See [15.12.2 SPI Status and Control Register](#).

NOTE: A logic 1 voltage on the \overline{SS} pin of a slave SPI puts the MISO pin in a high-impedance state. The slave SPI ignores all incoming SPSCCK clocks, even if it was already in the middle of a transmission.

When an SPI is configured as a master, the \overline{SS} input can be used in conjunction with the MODF flag to prevent multiple masters from driving MOSI and SPSCCK.

(See [15.6.2 Mode Fault Error](#).) For the state of the \overline{SS} pin to set the MODF flag, the MODFEN bit in the SPSCK register must be set. If the MODFEN bit is low for an SPI master, the \overline{SS} pin can be used as a general-purpose I/O under the control of the data direction register of the shared I/O port. With MODFEN high, it is an input-only pin to the SPI regardless of the state of the data direction register of the shared I/O port.

The CPU can always read the state of the \overline{SS} pin by configuring the appropriate pin as an input and reading the port data register. See [Table 15-3](#).

Table 15-3. SPI Configuration

SPE	SPMSTR	MODFEN	SPI Configuration	State of \overline{SS} Logic
0	X ⁽¹⁾	X	Not enabled	General-purpose I/O; \overline{SS} ignored by SPI
1	0	X	Slave	Input-only to SPI
1	1	0	Master without MODF	General-purpose I/O; \overline{SS} ignored by SPI
1	1	1	Master with MODF	Input-only to SPI

1. X = don't care

15.11.5 V_{SS} (Clock Ground)

V_{SS} is the ground return for the serial clock pin, SPSCK, and the ground for the port output buffers. To reduce the ground return path loop and minimize radio frequency (RF) emissions, connect the ground pin of the slave to the V_{SS} pin of the master.

15.12 I/O Registers

Three registers control and monitor SPI operation:

- SPI control register, SPCR
- SPI status and control register, SPSCR
- SPI data register, SPDR

15.12.1 SPI Control Register

The SPI control register (SPCR):

- Enables SPI module interrupt requests
- Selects CPU interrupt requests or DMA service requests
- Configures the SPI module as master or slave
- Selects serial clock polarity and phase
- Configures the SPSCK, MOSI, and MISO pins as open-drain outputs
- Enables the SPI module

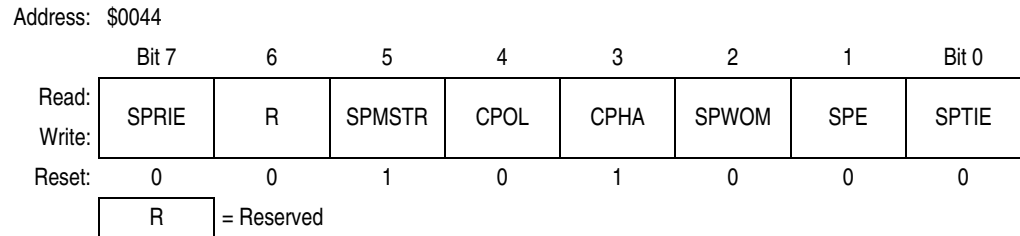

Figure 15-14. SPI Control Register (SPCR)

SPRIE — SPI Receiver Interrupt Enable Bit

This read/write bit enables CPU interrupt requests generated by the SPRF bit. The SPRF bit is set when a byte transfers from the shift register to the receive data register. Reset clears the SPRIE bit.

- 1 = SPRF CPU interrupt requests enabled
- 0 = SPRF CPU interrupt requests disabled

SPMSTR — SPI Master Bit

This read/write bit selects master mode operation or slave mode operation. Reset sets the SPMSTR bit.

- 1 = Master mode
- 0 = Slave mode

CPOL — Clock Polarity Bit

This read/write bit determines the logic state of the SPSCCK pin between transmissions. See Figure 15-5 and Figure 15-7. To transmit data between SPI modules, the SPI modules must have identical CPOL values. Reset clears the CPOL bit.

CPHA — Clock Phase Bit

This read/write bit controls the timing relationship between the serial clock and SPI data. See Figure 15-5 and Figure 15-7. To transmit data between SPI modules, the SPI modules must have identical CPHA bits. When CPHA = 0, the \overline{SS} pin of the slave SPI module must be set to logic 1 between bytes. See Figure 15-13. Reset sets the CPHA bit.

When CPHA = 0 for a slave, the falling edge of \overline{SS} indicates the beginning of the transmission. This causes the SPI to leave its idle state and begin driving the MISO pin with the MSB of its data, once the transmission begins, no new data is allowed into the shift register from the data register. Therefore, the slave data register must be loaded with the desired transmit data before the falling edge of \overline{SS} . Any data written after the falling edge is stored in the data register and transferred to the shift register at the current transmission.

When CPHA = 1 for a slave, the first edge of the SPSCCK indicates the beginning of the transmission. The same applies when \overline{SS} is high for a slave. The MISO pin is held in a high-impedance state, and the incoming SPSCCK is ignored. In certain cases, it may also cause the MODF flag to be set. See 15.6.2 Mode Fault Error. A logic 1 on the \overline{SS} pin does not in any way affect the state of the SPI state machine.

SPWOM — SPI Wired-OR Mode Bit

This read/write bit disables the pullup devices on pins SPSCCK, MOSI, and MISO so that those pins become open-drain outputs.

1 = Wired-OR SPSCCK, MOSI, and MISO pins

0 = Normal push-pull SPSCCK, MOSI, and MISO pins

SPE — SPI Enable Bit

This read/write bit enables the SPI module. Clearing SPE causes a partial reset of the SPI. See **15.8 Resetting the SPI**. Reset clears the SPE bit.

1 = SPI module enabled

0 = SPI module disabled

SPTIE— SPI Transmit Interrupt Enable Bit

This read/write bit enables CPU interrupt requests generated by the SPTE bit. SPTE is set when a byte transfers from the transmit data register to the shift register. Reset clears the SPTIE bit.

1 = SPTE CPU interrupt requests enabled

0 = SPTE CPU interrupt requests disabled

15.12.2 SPI Status and Control Register

The SPI status and control register (SPSCR) contains flags to signal these conditions:

- Receive data register full
- Failure to clear SPRF bit before next byte is received (overflow error)
- Inconsistent logic level on \overline{SS} pin (mode fault error)
- Transmit data register empty

The SPI status and control register also contains bits that perform these functions:

- Enable error interrupts
- Enable mode fault error detection
- Select master SPI baud rate

Address: \$0045

	Bit 7	6	5	4	3	2	1	Bit 0
Read:	SPRF	ERRIE	OVRF	MODF	SPTIE	MODFEN	SPR1	SPR0
Write:	R		R	R	R			
Reset:	0	0	0	0	1	0	0	0
	R		= Reserved					

Figure 15-15. SPI Status and Control Register (SPSCR)

SPRF — SPI Receiver Full Bit

This clearable, read-only flag is set each time a byte transfers from the shift register to the receive data register. SPRF generates a CPU interrupt request if the SPRIE bit in the SPI control register is set also.

During an SPRF CPU interrupt (DMAS = 0), the CPU clears SPRF by reading the SPI status and control register with SPRF set and then reading the SPI data register.

Reset clears the SPRF bit.

- 1 = Receive data register full
- 0 = Receive data register not full

ERRIE — Error interrupt Enable Bit

This read/write bit enables the MODF and OVRF bits to generate CPU interrupt requests. Reset clears the ERRIE bit.

- 1 = MODF and OVRF can generate CPU interrupt requests.
- 0 = MODF and OVRF cannot generate CPU interrupt requests.

OVRF — Overflow Bit

This clearable, read-only flag is set if software does not read the byte in the receive data register before the next full byte enters the shift register. In an overflow condition, the byte already in the receive data register is unaffected, and the byte that shifted in last is lost. Clear the OVRF bit by reading the SPI status and control register with OVRF set and then reading the receive data register. Reset clears the OVRF bit.

- 1 = Overflow
- 0 = No overflow

MODF — Mode Fault Bit

This clearable, read-only flag is set in a slave SPI if the \overline{SS} pin goes high during a transmission with the MODFEN bit set. In a master SPI, the MODF flag is set if the \overline{SS} pin goes low at any time with the MODFEN bit set. Clear the MODF bit by reading the SPI status and control register (SPSCR) with MODF set and then writing to the SPI control register (SPCR). Reset clears the MODF bit.

- 1 = \overline{SS} pin at inappropriate logic level
- 0 = \overline{SS} pin at appropriate logic level

SPTIE — SPI Transmitter Empty Bit

This clearable, read-only flag is set each time the transmit data register transfers a byte into the shift register. SPTIE generates an SPTIE CPU interrupt request or an SPTIE DMA service request if the SPTIE bit in the SPI control register is set also.

NOTE: Do not write to the SPI data register unless the SPTIE bit is high.

For an idle master or idle slave that has no data loaded into its transmit buffer, the SPTIE will be set again within two bus cycles since the transmit buffer empties into the shift register. This allows the user to queue up a 16-bit value to send. For an already active slave, the load of the shift register cannot occur until

the transmission is completed. This implies that a back-to-back write to the transmit data register is not possible. The SPTE indicates when the next write can occur.

Reset sets the SPTE bit.

1 = Transmit data register empty

0 = Transmit data register not empty

MODFEN — Mode Fault Enable Bit

This read/write bit, when set to 1, allows the MODF flag to be set. If the MODF flag is set, clearing the MODFEN does not clear the MODF flag. If the SPI is enabled as a master and the MODFEN bit is low, then the \overline{SS} pin is available as a general-purpose I/O.

If the MODFEN bit is set, then this pin is not available as a general-purpose I/O. When the SPI is enabled as a slave, the \overline{SS} pin is not available as a general-purpose I/O regardless of the value of MODFEN. See [15.11.4 SS \(Slave Select\)](#).

If the MODFEN bit is low, the level of the \overline{SS} pin does not affect the operation of an enabled SPI configured as a master. For an enabled SPI configured as a slave, having MODFEN low only prevents the MODF flag from being set. It does not affect any other part of SPI operation. See [15.6.2 Mode Fault Error](#).

SPR1 and SPR0 — SPI Baud Rate Select Bits

In master mode, these read/write bits select one of four baud rates as shown in [Table 15-4](#). SPR1 and SPR0 have no effect in slave mode. Reset clears SPR1 and SPR0.

Table 15-4. SPI Master Baud Rate Selection

SPR1:SPR0	Baud Rate Divisor (BD)
00	2
01	8
10	32
11	128

Use this formula to calculate the SPI baud rate:

$$\text{Baud rate} = \frac{\text{CGMOUT}}{2 \times \text{BD}}$$

where:

CGMOUT = base clock output of the clock generator module (CGM)

BD = baud rate divisor

15.12.3 SPI Data Register

The SPI data register consists of the read-only receive data register and the write-only transmit data register. Writing to the SPI data register writes data into the transmit data register. Reading the SPI data register reads data from the receive data register. The transmit data and receive data registers are separate registers that can contain different values. See [Figure 15-3](#).

Address: \$0046

	Bit 7	6	5	4	3	2	1	Bit 0
Read:	R7	R6	R5	R4	R3	R2	R1	R0
Write:	T7	T6	T5	T4	T3	T2	T1	T0
Reset:	Indeterminate after reset							

Figure 15-16. SPI Data Register (SPDR)

R7:R0/T7:T0 — Receive/Transmit Data Bits

NOTE: Do not use read-modify-write instructions on the SPI data register since the register read is not the same as the register written.

Section 16. Timer Interface A (TIMA)

16.1 Introduction

This section describes the timer interface module A (TIMA). The TIMA is a 4-channel timer that provides:

- Timing reference with input capture
- Output compare
- Pulse-width modulator functions

Figure 16-2 is a block diagram of the TIMA.

16.2 Features

Features of the TIMA include:

- Four input capture/output compare channels:
 - Rising-edge, falling-edge, or any-edge input capture trigger
 - Set, clear, or toggle output compare action
- Buffered and unbuffered pulse-width modulator (PWM) signal generation
- Programmable TIMA clock input:
 - 7-frequency internal bus clock prescaler selection
 - External TIMA clock input (4-MHz maximum frequency)
- Free-running or modulo up-count operation
- Toggle any channel pin on overflow
- TIMA counter stop and reset bits

Timer Interface A (TIMA)

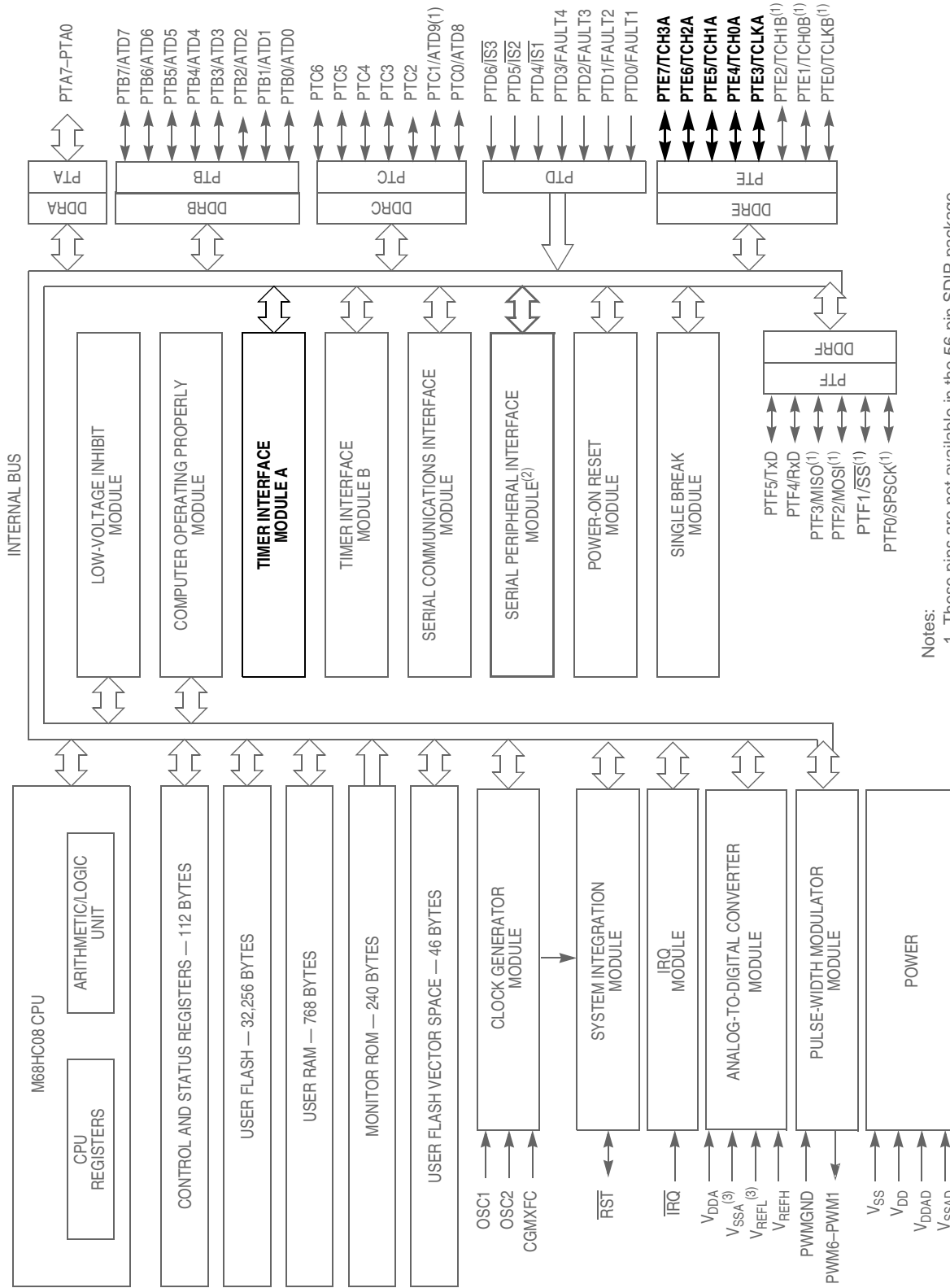

Notes:
 1. These pins are not available in the 56-pin SDIP package.
 2. This module is not available in the 56-pin SDIP package.
 3. In the 56-pin SDIP package, these pins are bonded together.

Figure 16-1. Block Diagram Highlighting TIMA Block and Pins

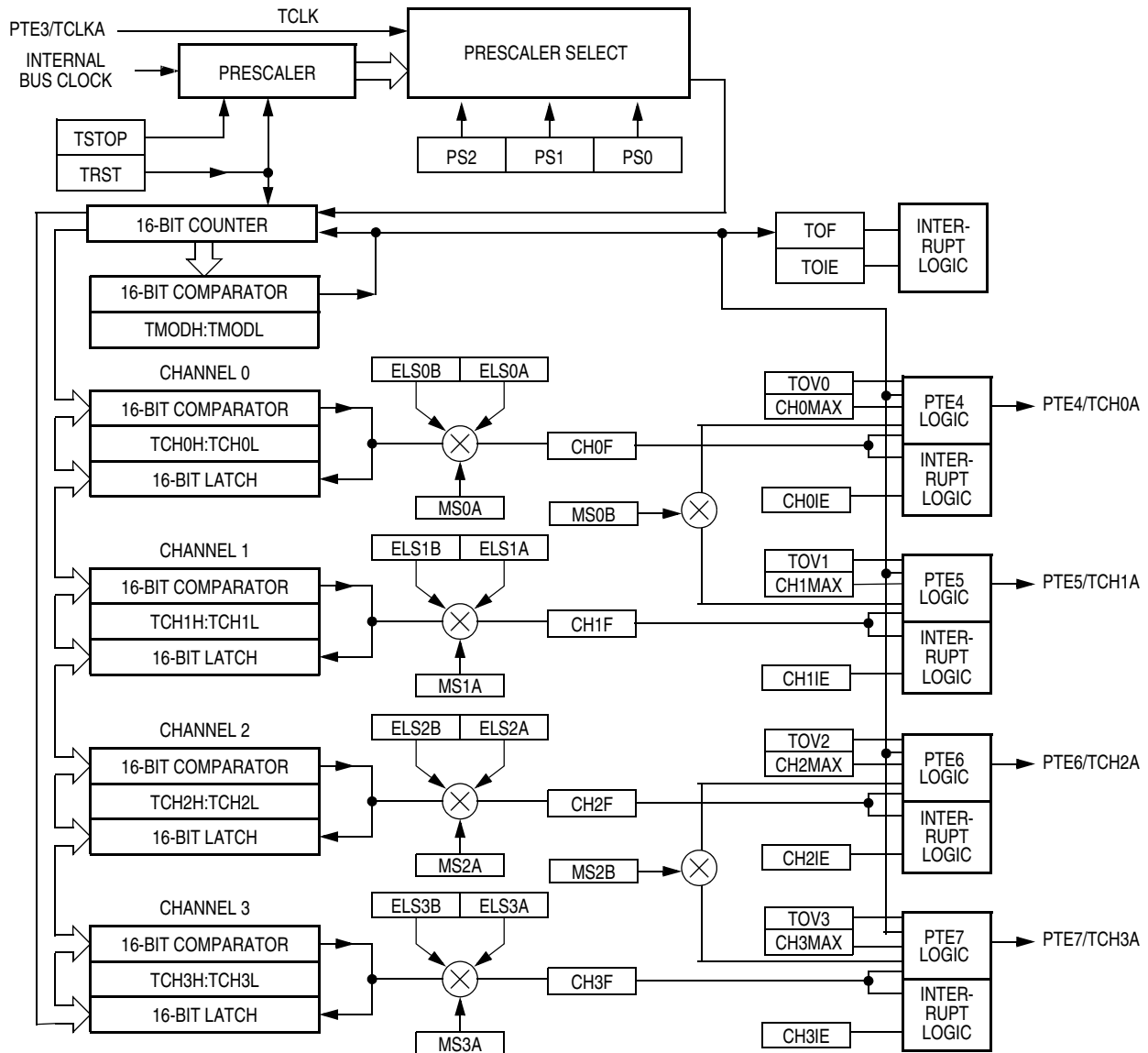

Figure 16-2. TIMA Block Diagram

Freescale Semiconductor, Inc.

Timer Interface A (TIMA)

Addr.	Register Name	Bit 7	6	5	4	3	2	1	Bit 0	
\$000E	TIMA Status/Control Register (TASC) See page 245.	Read:	TOF	TOIE	TSTOP	0	0	PS2	PS1	PS0
		Write:	0			TRST	R			
		Reset:	0	0	1	0	0	0	0	0
\$000F	TIMA Counter Register High (TACNTH) See page 247.	Read:	Bit 15	Bit 14	Bit 13	Bit 12	Bit 11	Bit 10	Bit 9	Bit 8
		Write:	R	R	R	R	R	R	R	R
		Reset:	0	0	0	0	0	0	0	0
\$0010	TIMA Counter Register Low (TACNTL) See page 247.	Read:	Bit 7	Bit 6	Bit 5	Bit 4	Bit 3	Bit 2	Bit 1	Bit 0
		Write:	R	R	R	R	R	R	R	R
		Reset:	0	0	0	0	0	0	0	0
\$0011	TIMA Counter Modulo Register High (TAMODH) See page 248.	Read:	Bit 15	14	13	12	11	10	9	Bit 8
		Write:								
		Reset:	1	1	1	1	1	1	1	1
\$0012	TIMA Counter Modulo Register Low (TAMODL) See page 248.	Read:	Bit 7	6	5	4	3	2	1	Bit 0
		Write:								
		Reset:	1	1	1	1	1	1	1	1
\$0013	TIMA Channel 0 Status/Control Register (TASC0) See page 249.	Read:	CH0F	CH0IE	MS0B	MS0A	ELS0B	ELS0A	TOV0	CH0MAX
		Write:	0							
		Reset:	0	0	0	0	0	0	0	0
\$0014	TIMA Channel 0 Register High (TACH0H) See page 252.	Read:	Bit 15	14	13	12	11	10	9	Bit 8
		Write:								
		Reset:	Indeterminate after reset							
\$0015	TIMA Channel 0 Register Low (TACH0L) See page 252.	Read:	Bit 7	6	5	4	3	2	1	Bit 0
		Write:								
		Reset:	Indeterminate after reset							
\$0016	TIMA Channel 1 Status/Control Register (TASC1) See page 249.	Read:	CH1F	CH1IE	0	MS1A	ELS1B	ELS1A	TOV1	CH1MAX
		Write:	0		R					
		Reset:	0	0	0	0	0	0	0	0
\$0017	TIMA Channel 1 Register High (TACH1H) See page 252.	Read:	Bit 15	14	13	12	11	10	9	Bit 8
		Write:								
		Reset:	Indeterminate after reset							
\$0018	TIMA Channel 1 Register Low (TACH1L) See page 252.	Read:	Bit 7	6	5	4	3	2	1	Bit 0
		Write:								
		Reset:	Indeterminate after reset							
\$0019	TIMA Channel 2 Status/Control Register (TASC2) See page 249.	Read:	CH2F	CH2IE	MS2B	MS2A	ELS2B	ELS2A	TOV2	CH2MAX
		Write:	0							
		Reset:	0	0	0	0	0	0	0	0

R = Reserved

Figure 16-3. TIM I/O Register Summary

Addr.	Register Name		Bit 7	6	5	4	3	2	1	Bit 0
\$001A	TIMA Channel 2 Register High (TACH2H) See page 252.	Read:								
		Write:	Bit 15	14	13	12	11	10	9	Bit 8
		Reset:	Indeterminate after reset							
\$001B	TIMA Channel 2 Register Low (TACH2L) See page 252.	Read:								
		Write:	Bit 7	6	5	4	3	2	1	Bit 0
		Reset:	Indeterminate after reset							
\$001C	TIMA Channel 3 Status/Control Register (TASC3) See page 249.	Read:	CH3F	CH3IE	0	MS3A	ELS3B	ELS3A	TOV3	CH3MAX
		Write:	0		R					
		Reset:	0	0	0	0	0	0	0	0
\$001D	TIMA Channel 3 Register High (TACH3H) See page 252.	Read:								
		Write:	Bit 15	14	13	12	11	10	9	Bit 8
		Reset:	Indeterminate after reset							
\$001E	TIMA Channel 3 Register Low (TACH3L) See page 252.	Read:								
		Write:	Bit 7	6	5	4	3	2	1	Bit 0
		Reset:	Indeterminate after reset							

R

 = Reserved

Figure 16-3. TIM I/O Register Summary (Continued)

16.3 Functional Description

Figure 16-2 shows the TIMA structure. The central component of the TIMA is the 16-bit TIMA counter that can operate as a free-running counter or a modulo up-counter. The TIMA counter provides the timing reference for the input capture and output compare functions. The TIMA counter modulo registers, TAMODH–TAMODL, control the modulo value of the TIMA counter. Software can read the TIMA counter value at any time without affecting the counting sequence.

The four TIMA channels are programmable independently as input capture or output compare channels.

16.3.1 TIMA Counter Prescaler

The TIMA clock source can be one of the seven prescaler outputs or the TIMA clock pin, PTE3/TCLKA. The prescaler generates seven clock rates from the internal bus clock. The prescaler select bits, PS[2:0], in the TIMA status and control register select the TIMA clock source.

16.3.2 Input Capture

An input capture function has three basic parts:

1. Edge select logic
2. Input capture latch
3. 16-bit counter

Two 8-bit registers, which make up the 16-bit input capture register, are used to latch the value of the free-running counter after the corresponding input capture edge detector senses a defined transition. The polarity of the active edge is programmable. The level transition which triggers the counter transfer is defined by the corresponding input edge bits (ELSxB and ELSxA in TASC0–TASC3 control registers with x referring to the active channel number). When an active edge occurs on the pin of an input capture channel, the TIMA latches the contents of the TIMA counter into the TIMA channel registers, TACHxH–TACHxL. Input captures can generate TIMA CPU interrupt requests. Software can determine that an input capture event has occurred by enabling input capture interrupts or by polling the status flag bit.

The free-running counter contents are transferred to the TIMA channel status and control register (TACHxH–TACHxL, see [16.7.5 TIMA Channel Registers](#)) on each proper signal transition regardless of whether the TIMA channel flag (CH0F–CH3F in TASC0–TASC3 registers) is set or clear. When the status flag is set, a CPU interrupt is generated if enabled. The value of the count latched or “captured” is the time of the event. Because this value is stored in the input capture register two bus cycles after the actual event occurs, user software can respond to this event at a later time and determine the actual time of the event. However, this must be done prior to another input capture on the same pin; otherwise, the previous time value will be lost.

By recording the times for successive edges on an incoming signal, software can determine the period and/or pulse width of the signal. To measure a period, two successive edges of the same polarity are captured. To measure a pulse width, two alternate polarity edges are captured. Software should track the overflows at the 16-bit module counter to extend its range.

Another use for the input capture function is to establish a time reference. In this case, an input capture function is used in conjunction with an output compare function. For example, to activate an output signal a specified number of clock cycles after detecting an input event (edge), use the input capture function to record the time at which the edge occurred. A number corresponding to the desired delay is added to this captured value and stored to an output compare register (see [16.7.5 TIMA Channel Registers](#)). Because both input captures and output compares are referenced to the same 16-bit modulo counter, the delay can be controlled to the resolution of the counter independent of software latencies.

Reset does not affect the contents of the input capture channel registers.

16.3.3 Output Compare

With the output compare function, the TIMA can generate a periodic pulse with a programmable polarity, duration, and frequency. When the counter reaches the value in the registers of an output compare channel, the TIMA can set, clear, or toggle the channel pin. Output compares can generate TIMA CPU interrupt requests.

16.3.3.1 Unbuffered Output Compare

Any output compare channel can generate unbuffered output compare pulses as described in [16.3.3 Output Compare](#). The pulses are unbuffered because changing the output compare value requires writing the new value over the old value currently in the TIMA channel registers.

An unsynchronized write to the TIMA channel registers to change an output compare value could cause incorrect operation for up to two counter overflow periods. For example, writing a new value before the counter reaches the old value but after the counter reaches the new value prevents any compare during that counter overflow period. Also, using a TIMA overflow interrupt routine to write a new, smaller output compare value may cause the compare to be missed. The TIMA may pass the new value before it is written.

Use this method to synchronize unbuffered changes in the output compare value on channel x:

- When changing to a smaller value, enable channel x output compare interrupts and write the new value in the output compare interrupt routine. The output compare interrupt occurs at the end of the current output compare pulse. The interrupt routine has until the end of the counter overflow period to write the new value.
- When changing to a larger output compare value, enable TIMA overflow interrupts and write the new value in the TIMA overflow interrupt routine. The TIMA overflow interrupt occurs at the end of the current counter overflow period. Writing a larger value in an output compare interrupt routine (at the end of the current pulse) could cause two output compares to occur in the same counter overflow period.

16.3.3.2 Buffered Output Compare

Channels 0 and 1 can be linked to form a buffered output compare channel whose output appears on the PTE4/TCH0A pin. The TIMA channel registers of the linked pair alternately control the output.

Setting the MS0B bit in TIMA channel 0 status and control register (TASC0) links channel 0 and channel 1. The output compare value in the TIMA channel 0 registers initially controls the output on the PTE4/TCH0A pin. Writing to the TIMA channel 1 registers enables the TIMA channel 1 registers to synchronously control the output after the TIMA overflows. At each subsequent overflow, the TIMA

channel registers (0 or 1) that control the output are the ones written to last. TASC0 controls and monitors the buffered output compare function, and TIMA channel 1 status and control register (TASC1) is unused. While the MS0B bit is set, the channel 1 pin, PTE5/TCH1A, is available as a general-purpose I/O pin.

Channels 2 and 3 can be linked to form a buffered output compare channel whose output appears on the PTE6/TCH2A pin. The TIMA channel registers of the linked pair alternately control the output.

Setting the MS2B bit in TIMA channel 2 status and control register (TASC2) links channel 2 and channel 3. The output compare value in the TIMA channel 2 registers initially controls the output on the PTE6/TCH2A pin. Writing to the TIMA channel 3 registers enables the TIMA channel 3 registers to synchronously control the output after the TIMA overflows. At each subsequent overflow, the TIMA channel registers (2 or 3) that control the output are the ones written to last. TASC2 controls and monitors the buffered output compare function, and TIMA channel 3 status and control register (TASC3) is unused. While the MS2B bit is set, the channel 3 pin, PTE7/TCH3A, is available as a general-purpose I/O pin.

NOTE: *In buffered output compare operation, do not write new output compare values to the currently active channel registers. User software should track the currently active channel to prevent writing a new value to the active channel. Writing to the active channel registers is the same as generating unbuffered output compares.*

16.3.4 Pulse-Width Modulation (PWM)

By using the toggle-on-overflow feature with an output compare channel, the TIMA can generate a PWM signal. The value in the TIMA counter modulo registers determines the period of the PWM signal. The channel pin toggles when the counter reaches the value in the TIMA counter modulo registers. The time between overflows is the period of the PWM signal.

As [Figure 16-4](#) shows, the output compare value in the TIMA channel registers determines the pulse width of the PWM signal. The time between overflow and output compare is the pulse width. Program the TIMA to clear the channel pin on output compare if the polarity of the PWM pulse is 1 (ELSxA = 0). Program the TIMA to set the pin if the polarity of the PWM pulse is 0 (ELSxA = 1).

The value in the TIMA counter modulo registers and the selected prescaler output determines the frequency of the PWM output. The frequency of an 8-bit PWM signal is variable in 256 increments. Writing \$00FF (255) to the TIMA counter modulo registers produces a PWM period of 256 times the internal bus clock period if the prescaler select value is \$000 (see [16.7.1 TIMA Status and Control Register](#)).

The value in the TIMA channel registers determines the pulse width of the PWM output. The pulse width of an 8-bit PWM signal is variable in 256 increments. Writing \$0080 (128) to the TIMA channel registers produces a duty cycle of 128/256 or 50 percent.

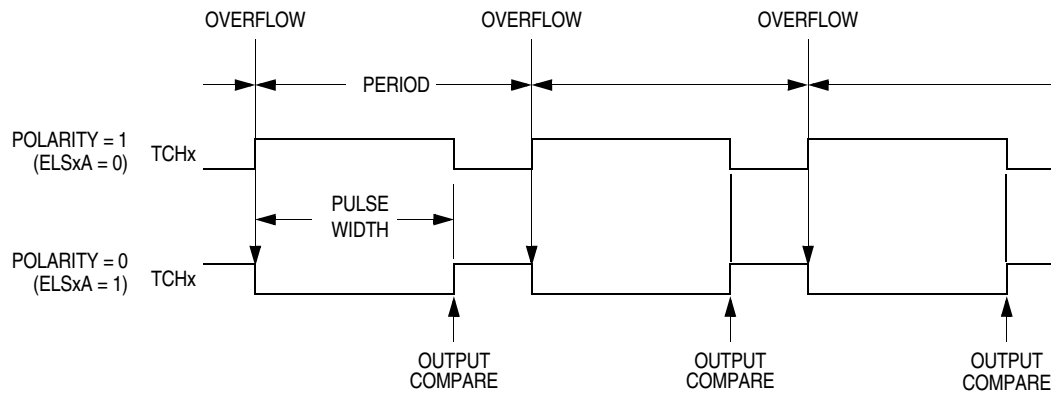

Figure 16-4. PWM Period and Pulse Width

16.3.4.1 Unbuffered PWM Signal Generation

Any output compare channel can generate unbuffered PWM pulses as described in **16.3.4 Pulse-Width Modulation (PWM)**. The pulses are unbuffered because changing the pulse width requires writing the new pulse width value over the value currently in the TIMA channel registers.

An unsynchronized write to the TIMA channel registers to change a pulse width value could cause incorrect operation for up to two PWM periods. For example, writing a new value before the counter reaches the old value but after the counter reaches the new value prevents any compare during that PWM period. Also, using a TIMA overflow interrupt routine to write a new, smaller pulse width value may cause the compare to be missed. The TIMA may pass the new value before it is written to the TIMA channel registers.

Use this method to synchronize unbuffered changes in the PWM pulse width on channel x:

- When changing to a shorter pulse width, enable channel x output compare interrupts and write the new value in the output compare interrupt routine. The output compare interrupt occurs at the end of the current pulse. The interrupt routine has until the end of the PWM period to write the new value.
- When changing to a longer pulse width, enable TIMA overflow interrupts and write the new value in the TIMA overflow interrupt routine. The TIMA overflow interrupt occurs at the end of the current PWM period. Writing a larger value in an output compare interrupt routine (at the end of the current pulse) could cause two output compares to occur in the same PWM period.

NOTE: *In PWM signal generation, do not program the PWM channel to toggle on output compare. Toggling on output compare prevents reliable 0 percent duty cycle generation and removes the ability of the channel to self-correct in the event of software error or noise. Toggling on output compare also can cause incorrect PWM signal generation when changing the PWM pulse width to a new, much larger value.*

16.3.4.2 Buffered PWM Signal Generation

Channels 0 and 1 can be linked to form a buffered PWM channel whose output appears on the PTE4/TCH0A pin. The TIMA channel registers of the linked pair alternately control the pulse width of the output.

Setting the MS0B bit in TIMA channel 0 status and control register (TASC0) links channel 0 and channel 1. The TIMA channel 0 registers initially control the pulse width on the PTE4/TCH0A pin. Writing to the TIMA channel 1 registers enables the TIMA channel 1 registers to synchronously control the pulse width at the beginning of the next PWM period. At each subsequent overflow, the TIMA channel registers (0 or 1) that control the pulse width are the ones written to last. TASC0 controls and monitors the buffered PWM function, and TIMA channel 1 status and control register (TASC1) is unused. While the MS0B bit is set, the channel 1 pin, PTE5/TCH1A, is available as a general-purpose I/O pin.

Channels 2 and 3 can be linked to form a buffered PWM channel whose output appears on the PTE6/TCH2A pin. The TIMA channel registers of the linked pair alternately control the pulse width of the output.

Setting the MS2B bit in TIMA channel 2 status and control register (TASC2) links channel 2 and channel 3. The TIMA channel 2 registers initially control the pulse width on the PTE6/TCH2A pin. Writing to the TIMA channel 3 registers enables the TIMA channel 3 registers to synchronously control the pulse width at the beginning of the next PWM period. At each subsequent overflow, the TIMA channel registers (2 or 3) that control the pulse width are written to last. TASC2 controls and monitors the buffered PWM function, and TIMA channel 3 status and control register (TASC3) is unused. While the MS2B bit is set, the channel 3 pin, PTE7/TCH3A, is available as a general-purpose I/O pin.

NOTE: *In buffered PWM signal generation, do not write new pulse width values to the currently active channel registers. User software should track the currently active channel to prevent writing a new value to the active channel. Writing to the active channel registers is the same as generating unbuffered PWM signals.*

16.3.4.3 PWM Initialization

To ensure correct operation when generating unbuffered or buffered PWM signals, use this initialization procedure:

1. In the TIMA status and control register (TASC):
 - a. Stop the TIMA counter by setting the TIMA stop bit, TSTOP.
 - b. Reset the TIMA counter and prescaler by setting the TIMA reset bit, TRST.
2. In the TIMA counter modulo registers (TAMODH–TAMODL), write the value for the required PWM period.

3. In the TIMA channel x registers (TACHxH–TACHxL), write the value for the required pulse width.
4. In TIMA channel x status and control register (TSCx):
 - a. Write 0:1 (for unbuffered output compare or PWM signals) or 1:0 (for buffered output compare or PWM signals) to the mode select bits, MSxB–MSxA. (See [Table 16-2](#).)
 - b. Write 1 to the toggle-on-overflow bit, TOVx.
 - c. Write 1:0 (polarity 1 — to clear output on compare) or 1:1 (polarity 0 — to set output on compare) to the edge/level select bits, ELSxB–ELSxA. The output action on compare must force the output to the complement of the pulse width level. (See [Table 16-2](#).)

NOTE: *In PWM signal generation, do not program the PWM channel to toggle on output compare. Toggling on output compare prevents reliable 0 percent duty cycle generation and removes the ability of the channel to self-correct in the event of software error or noise. Toggling on output compare can also cause incorrect PWM signal generation when changing the PWM pulse width to a new, much larger value.*

5. In the TIMA status control register (TASC), clear the TIMA stop bit, TSTOP.

Setting MS0B links channels 0 and 1 and configures them for buffered PWM operation. The TIMA channel 0 registers (TACH0H–TACH0L) initially control the buffered PWM output. TIMA status control register 0 (TASC0) controls and monitors the PWM signal from the linked channels. MS0B takes priority over MS0A.

Setting MS2B links channels 2 and 3 and configures them for buffered PWM operation. The TIMA channel 2 registers (TACH2H–TACH2L) initially control the buffered PWM output. TIMA status control register 2 (TASC2) controls and monitors the PWM signal from the linked channels. MS2B takes priority over MS2A.

Clearing the toggle-on-overflow bit, TOVx, inhibits output toggles on TIMA overflows. Subsequent output compares try to force the output to a state it is already in and have no effect. The result is a 0 percent duty cycle output.

Setting the channel x maximum duty cycle bit (CHxMAX) and setting the TOVx bit generates a 100 percent duty cycle output. (See [16.7.4 TIMA Channel Status and Control Registers](#).)

16.4 Interrupts

These TIMA sources can generate interrupt requests:

- TIMA overflow flag (TOF) — The timer overflow flag (TOF) bit is set when the TIMA counter reaches the modulo value programmed in the TIMA counter modulo registers. The TIMA overflow interrupt enable bit, TOIE, enables TIMA overflow interrupt requests. TOF and TOIE are in the TIMA status and control registers.
- TIMA channel flags (CH3F–CH0F) — The CHxF bit is set when an input capture or output compare occurs on channel x. Channel x TIMA CPU interrupt requests are controlled by the channel x interrupt enable bit, CHxIE.

16.5 Wait Mode

The WAIT instruction puts the MCU in low power-consumption standby mode.

The TIMA remains active after the execution of a WAIT instruction. In wait mode, the TIMA registers are not accessible by the CPU. Any enabled CPU interrupt request from the TIMA can bring the MCU out of wait mode.

If TIMA functions are not required during wait mode, reduce power consumption by stopping the TIMA before executing the WAIT instruction.

16.6 I/O Signals

Port E shares five of its pins with the TIMA:

- PTE3/TCLKA is an external clock input to the TIMA prescaler.
- The four TIMA channel I/O pins are PTE4/TCH0A, PTE5/TCH1A, PTE6/TCH2A, and PTE7/TCH3A.

16.6.1 TIMA Clock Pin (PTE3/TCLKA)

PTE3/TCLKA is an external clock input that can be the clock source for the TIMA counter instead of the prescaled internal bus clock. Select the PTE3/TCLKA input by writing logic 1s to the three prescaler select bits, PS[2:0]. See [16.7.1 TIMA Status and Control Register](#).

The maximum TCLK frequency is the least: 4 MHz or bus frequency ÷ 2.

PTE3/TCLKA is available as a general-purpose I/O pin when not used as the TIMA clock input. When the PTE3/TCLKA pin is the TIMA clock input, it is an input regardless of the state of the DDRE3 bit in data direction register E.

16.6.2 TIMA Channel I/O Pins (PTE4/TCH0A–PTE7/TCH3A)

Each channel I/O pin is programmable independently as an input capture pin or an output compare pin. PTE2/TCH0 and PTE4/TCH2 can be configured as buffered output compare or buffered PWM pins.

16.7 I/O Registers

These input/output (I/O) registers control and monitor TIMA operation:

- TIMA status and control register (TASC)
- TIMA control registers (TACNTH–TACNTL)
- TIMA counter modulo registers (TAMODH–TAMODL)
- TIMA channel status and control registers (TASC0, TASC1, TASC2, and TASC3)
- TIMA channel registers (TACH0H–TACH0L, TACH1H–TACH1L, TACH2H–TACH2L, and TACH3H–TACH3L)

16.7.1 TIMA Status and Control Register

The TIMA status and control register:

- Enables TIMA overflow interrupts
- Flags TIMA overflows
- Stops the TIMA counter
- Resets the TIMA counter
- Prescales the TIMA counter clock

Address: \$000E

	Bit 7	6	5	4	3	2	1	Bit 0
Read:	TOF	TOIE	TSTOP	0	0	PS2	PS1	PS0
Write:	0			TRST	R			
Reset:	0	0	1	0	0	0	0	0

R = Reserved

Figure 16-5. TIMA Status and Control Register (TASC)

TOF — TIMA Overflow Flag

This read/write flag is set when the TIMA counter reaches the modulo value programmed in the TIMA counter modulo registers. Clear TOF by reading the TIMA status and control register when TOF is set and then writing a logic 0 to TOF. If another TIMA overflow occurs before the clearing sequence is complete, then writing logic 0 to TOF has no effect. Therefore, a TOF interrupt request

cannot be lost due to inadvertent clearing of TOF. Reset clears the TOF bit. Writing a logic 1 to TOF has no effect.

1 = TIMA counter has reached modulo value.

0 = TIMA counter has not reached modulo value.

TOIE — TIMA Overflow Interrupt Enable Bit

This read/write bit enables TIMA overflow interrupts when the TOF bit becomes set. Reset clears the TOIE bit.

1 = TIMA overflow interrupts enabled

0 = TIMA overflow interrupts disabled

TSTOP — TIMA Stop Bit

This read/write bit stops the TIMA counter. Counting resumes when TSTOP is cleared. Reset sets the TSTOP bit, stopping the TIMA counter until software clears the TSTOP bit.

1 = TIMA counter stopped

0 = TIMA counter active

NOTE: Do not set the TSTOP bit before entering wait mode if the TIMA is required to exit wait mode. Also when the TSTOP bit is set and the timer is configured for input capture operation, input captures are inhibited until the TSTOP bit is cleared.

TRST — TIMA Reset Bit

Setting this write-only bit resets the TIMA counter and the TIMA prescaler. Setting TRST has no effect on any other registers. Counting resumes from \$0000. TRST is cleared automatically after the TIMA counter is reset and always reads as logic 0. Reset clears the TRST bit.

1 = Prescaler and TIMA counter cleared

0 = No effect

NOTE: Setting the TSTOP and TRST bits simultaneously stops the TIMA counter at a value of \$0000.

PS[2:0] — Prescaler Select Bits

These read/write bits select either the PTE3/TCLKA pin or one of the seven prescaler outputs as the input to the TIMA counter as [Table 16-1](#) shows. Reset clears the PS[2:0] bits.

Table 16-1. Prescaler Selection

PS[2:0]	TIMA Clock Source
000	Internal bus clock ÷ 1
001	Internal bus clock ÷ 2
010	Internal bus clock ÷ 4
011	Internal bus clock ÷ 8
100	Internal bus clock ÷ 16
101	Internal bus clock ÷ 32
110	Internal bus clock ÷ 64
111	PTE3/TCLKA

16.7.2 TIMA Counter Registers

The two read-only TIMA counter registers contain the high and low bytes of the value in the TIMA counter. Reading the high byte (TACNTH) latches the contents of the low byte (TACNTL) into a buffer. Subsequent reads of TACNTH do not affect the latched TACNTL value until TACNTL is read. Reset clears the TIMA counter registers. Setting the TIMA reset bit (TRST) also clears the TIMA counter registers.

NOTE: *If TACNTH is read during a break interrupt, be sure to unlatch TACNTL by reading TACNTL before exiting the break interrupt. Otherwise, TACNTL retains the value latched during the break.*

Register Name and Address:		TACNTH — \$000F							
		Bit 7	6	5	4	3	2	1	Bit 0
Read:		Bit 15	Bit 14	Bit 13	Bit 12	Bit 11	Bit 10	Bit 9	Bit 8
Write:		R	R	R	R	R	R	R	R
Reset:		0	0	0	0	0	0	0	0

Register Name and Address:		TACNTL — \$0010							
		Bit 7	6	5	4	3	2	1	Bit 0
Read:		Bit 7	Bit 6	Bit 5	Bit 4	Bit 3	Bit 2	Bit 1	Bit 0
Write:		R	R	R	R	R	R	R	R
Reset:		0	0	0	0	0	0	0	0

R

 = Reserved

Figure 16-6. TIMA Counter Registers (TACNTH and TACNTL)

Freescale Semiconductor, Inc.

16.7.3 TIMA Counter Modulo Registers

The read/write TIMA modulo registers contain the modulo value for the TIMA counter. When the TIMA counter reaches the modulo value, the overflow flag (TOF) becomes set, and the TIMA counter resumes counting from \$0000 at the next timer clock. Writing to the high byte (TAMODH) inhibits the TOF bit and overflow interrupts until the low byte (TAMODL) is written. Reset sets the TIMA counter modulo registers.

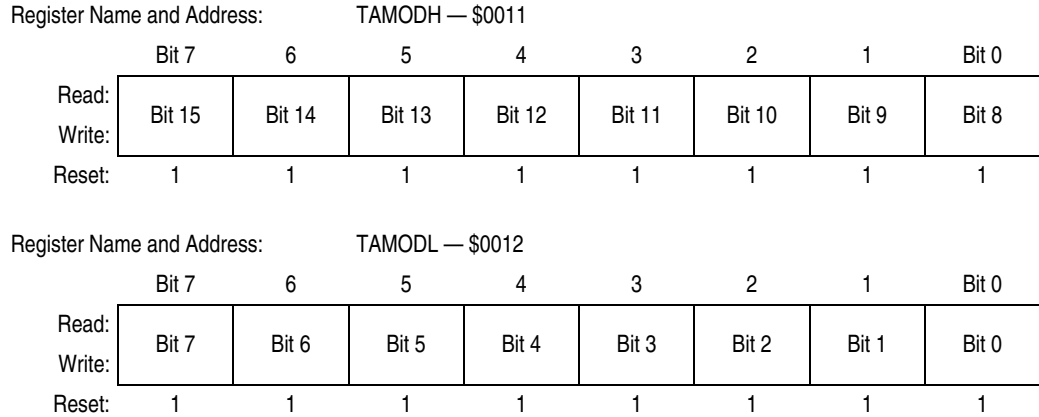

Figure 16-7. TIMA Counter Modulo Registers (TAMODH and TAMODL)

NOTE: Reset the TIMA counter before writing to the TIMA counter modulo registers.

16.7.4 TIMA Channel Status and Control Registers

Each of the TIMA channel status and control registers:

- Flags input captures and output compares
- Enables input capture and output compare interrupts
- Selects input capture, output compare, or PWM operation
- Selects high, low, or toggling output on output compare
- Selects rising edge, falling edge, or any edge as the active input capture trigger
- Selects output toggling on TIMA overflow
- Selects 0 percent and 100 percent PWM duty cycle
- Selects buffered or unbuffered output compare/PWM operation

Register Name and Address:		TASC0 — \$0013							
		Bit 7	6	5	4	3	2	1	Bit 0
Read:	CH0F	CH0IE	MS0B	MS0A	ELS0B	ELS0A	TOV0	CH0MAX	0
Write:	0								
Reset:	0	0	0	0	0	0	0	0	0

Register Name and Address:		TASC1 — \$0016							
		Bit 7	6	5	4	3	2	1	Bit 0
Read:	CH1F	CH1IE	0	MS1A	ELS1B	ELS1A	TOV1	CH1MAX	0
Write:	0		R						
Reset:	0	0	0	0	0	0	0	0	0

Register Name and Address:		TASC2 — \$0019							
		Bit 7	6	5	4	3	2	1	Bit 0
Read:	CH2F	CH2IE	MS2B	MS2A	ELS2B	ELS2A	TOV2	CH2MAX	0
Write:	0								
Reset:	0	0	0	0	0	0	0	0	0

Register Name and Address:		TASC3 — \$001C							
		Bit 7	6	5	4	3	2	1	Bit 0
Read:	CH3F	CH3IE	0	MS3A	ELS3B	ELS3A	TOV3	CH3MAX	0
Write:	0		R						
Reset:	0	0	0	0	0	0	0	0	0

R

 = Reserved

Figure 16-8. TIMA Channel Status and Control Registers (TASC0–TASC3)

CHxF — Channel x Flag Bit

When channel x is an input capture channel, this read/write bit is set when an active edge occurs on the channel x pin. When channel x is an output compare channel, CHxF is set when the value in the TIMA counter registers matches the value in the TIMA channel x registers.

When CHxIE = 1, clear CHxF by reading TIMA channel x status and control register with CHxF set, and then writing a 0 to CHxF. If another interrupt request occurs before the clearing sequence is complete, then writing 0 to CHxF has no effect. Therefore, an interrupt request cannot be lost due to inadvertent clearing of CHxF.

Reset clears the CHxF bit. Writing a 1 to CHxF has no effect.

1 = Input capture or output compare on channel x

0 = No input capture or output compare on channel x

CHxIE — Channel x Interrupt Enable Bit

This read/write bit enables TIMA CPU interrupts on channel x.

Reset clears the CHxIE bit.

1 = Channel x CPU interrupt requests enabled

0 = Channel x CPU interrupt requests disabled

MSxB — Mode Select Bit B

This read/write bit selects buffered output compare/PWM operation. MSxB exists only in the TIMA channel 0 and TIMA channel 2 status and control registers.

Setting MS0B disables the channel 1 status and control register and reverts TCH1A pin to general-purpose I/O.

Setting MS2B disables the channel 3 status and control register and reverts TCH3A pin to general-purpose I/O.

Reset clears the MSxB bit.

1 = Buffered output compare/PWM operation enabled

0 = Buffered output compare/PWM operation disabled

MSxA — Mode Select Bit A

When ELSxB:A ≠ 00, this read/write bit selects either input capture operation or unbuffered output compare/PWM operation. See [Table 16-2](#).

1 = Unbuffered output compare/PWM operation

0 = Input capture operation

When ELSxB:A = 00, this read/write bit selects the initial output level of the TCHxA pin once PWM, input capture, or output compare operation is enabled. See [Table 16-2](#). Reset clears the MSxA bit.

1 = Initial output level low

0 = Initial output level high

NOTE: Before changing a channel function by writing to the MSxB or MSxA bit, set the TSTOP and TRST bits in the TIMA status and control register (TASC).

ELSxB and ELSxA — Edge/Level Select Bits

When channel x is an input capture channel, these read/write bits control the active edge-sensing logic on channel x.

When channel x is an output compare channel, ELSxB and ELSxA control the channel x output behavior when an output compare occurs.

When ELSxB and ELSxA are both clear, channel x is not connected to port E, and pin PTE_x/TCH_xA is available as a general-purpose I/O pin. However, channel x is at a state determined by these bits and becomes transparent to the respective pin when PWM, input capture, or output compare mode is enabled. [Table 16-2](#) shows how ELSxB and ELSxA work. Reset clears the ELSxB and ELSxA bits.

NOTE: Before enabling a TIMA channel register for input capture operation, make sure that the PTE_x/TACH_x pin is stable for at least two bus clocks.

Table 16-2. Mode, Edge, and Level Selection

MSxB:MSxA	ELSxB:ELSxA	Mode	Configuration
X0	00	Output preset	Pin under port control; initialize timer output level high
X1	00		Pin under port control; initialize timer output level low
00	01	Input capture	Capture on rising edge only
00	10		Capture on falling edge only
00	11		Capture on rising or falling edge
01	00	Output compare or PWM	Software compare only
01	01		Toggle output on compare
01	10		Clear output on compare
01	11		Set output on compare
1X	01	Buffered output compare or buffered PWM	Toggle output on compare
1X	10		Clear output on compare
1X	11		Set output on compare

TOVx — Toggle-On-Overflow Bit

When channel x is an output compare channel, this read/write bit controls the behavior of the channel x output when the TIMA counter overflows. When channel x is an input capture channel, TOVx has no effect. Reset clears the TOVx bit.

1 = Channel x pin toggles on TIMA counter overflow.

0 = Channel x pin does not toggle on TIMA counter overflow.

NOTE: When TOVx is set, a TIMA counter overflow takes precedence over a channel x output compare if both occur at the same time.

CHxMAX — Channel x Maximum Duty Cycle Bit

When the TOVx is 1 and clear output on compare is selected, setting the CHxMAX bit forces the duty cycle of buffered and unbuffered PWM signals to 100 percent. As Figure 16-9 shows, CHxMAX bit takes effect in the cycle after it is set or cleared. The output stays at 100 percent duty cycle level until the cycle after CHxMAX is cleared.

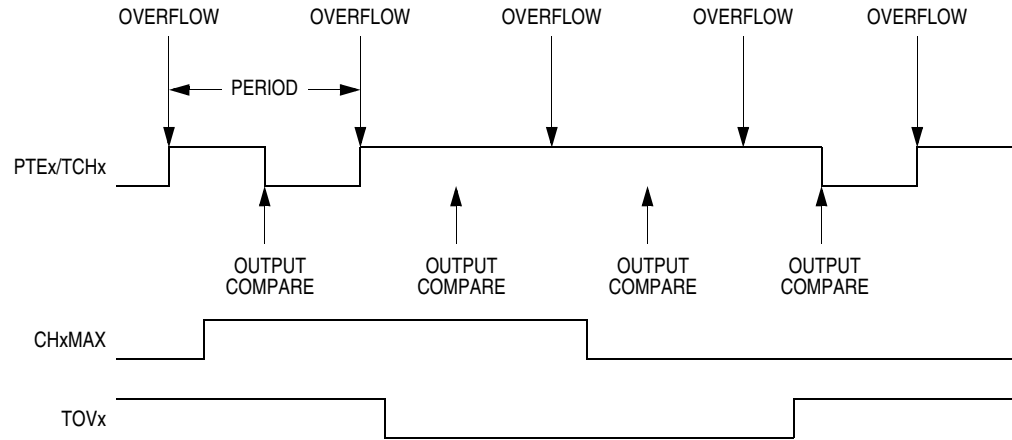

Figure 16-9. CHxMAX Latency

16.7.5 TIMA Channel Registers

These read/write registers contain the captured TIMA counter value of the input capture function or the output compare value of the output compare function. The state of the TIMA channel registers after reset is unknown.

In input capture mode ($MSxB:MSxA = 0:0$), reading the high byte of the TIMA channel x registers (TACHxH) inhibits input captures until the low byte (TACHxL) is read.

In output compare mode ($MSxB:MSxA \neq 0:0$), writing to the high byte of the TIMA channel x registers (TACHxH) inhibits output compares until the low byte (TACHxL) is written.

Register Name and Address: TACH0H — \$0014

	Bit 7	6	5	4	3	2	1	Bit 0
Read:	Bit 15	Bit 14	Bit 13	Bit 12	Bit 11	Bit 10	Bit 9	Bit 8
Write:								
Reset:	Indeterminate after reset							

Register Name and Address: TACH0L — \$0015

	Bit 7	6	5	4	3	2	1	Bit 0
Read:	Bit 7	Bit 6	Bit 5	Bit 4	Bit 3	Bit 2	Bit 1	Bit 0
Write:								
Reset:	Indeterminate after reset							

Figure 16-10. TIMA Channel Registers (TACH0H/L–TACH3H/L)

Register Name and Address: TACH1H — \$0017

	Bit 7	6	5	4	3	2	1	Bit 0
Read:	Bit 15	Bit 14	Bit 13	Bit 12	Bit 11	Bit 10	Bit 9	Bit 8
Write:	Bit 15	Bit 14	Bit 13	Bit 12	Bit 11	Bit 10	Bit 9	Bit 8
Reset:	Indeterminate after reset							

Register Name and Address: TACH1L — \$0018

	Bit 7	6	5	4	3	2	1	Bit 0
Read:	Bit 7	Bit 6	Bit 5	Bit 4	Bit 3	Bit 2	Bit 1	Bit 0
Write:	Bit 7	Bit 6	Bit 5	Bit 4	Bit 3	Bit 2	Bit 1	Bit 0
Reset:	Indeterminate after reset							

Register Name and Address: TACH2H — \$001A

	Bit 7	6	5	4	3	2	1	Bit 0
Read:	Bit 15	Bit 14	Bit 13	Bit 12	Bit 11	Bit 10	Bit 9	Bit 8
Write:	Bit 15	Bit 14	Bit 13	Bit 12	Bit 11	Bit 10	Bit 9	Bit 8
Reset:	Indeterminate after reset							

Register Name and Address: TACH2L — \$001B

	Bit 7	6	5	4	3	2	1	Bit 0
Read:	Bit 7	Bit 6	Bit 5	Bit 4	Bit 3	Bit 2	Bit 1	Bit 0
Write:	Bit 7	Bit 6	Bit 5	Bit 4	Bit 3	Bit 2	Bit 1	Bit 0
Reset:	Indeterminate after reset							

Register Name and Address: TACH3H — \$001D

	Bit 7	6	5	4	3	2	1	Bit 0
Read:	Bit 15	Bit 14	Bit 13	Bit 12	Bit 11	Bit 10	Bit 9	Bit 8
Write:	Bit 15	Bit 14	Bit 13	Bit 12	Bit 11	Bit 10	Bit 9	Bit 8
Reset:	Indeterminate after reset							

Register Name and Address: TACH3L — \$001E

	Bit 7	6	5	4	3	2	1	Bit 0
Read:	Bit 7	Bit 6	Bit 5	Bit 4	Bit 3	Bit 2	Bit 1	Bit 0
Write:	Bit 7	Bit 6	Bit 5	Bit 4	Bit 3	Bit 2	Bit 1	Bit 0
Reset:	Indeterminate after reset							

Figure 16-10. TIMA Channel Registers (TACH0H/L–TACH3H/L) (Continued)

Section 17. Timer Interface B (TIMB)

17.1 Introduction

This section describes the timer interface module B (TIMB). The TIMB is a 2-channel timer that provides:

- Timing reference with input capture
- Output compare
- Pulse-width modulation functions

Figure 17-2 is a block diagram of the TIMB.

NOTE: *The TIMB module is not available in the 56-pin shrink dual in-line package (SDIP).*

17.2 Features

Features of the TIMB include:

- Two input capture/output compare channels:
 - Rising-edge, falling-edge, or any-edge input capture trigger
 - Set, clear, or toggle output compare action
- Buffered and unbuffered pulse-width modulation (PWM) signal generation
- Programmable TIMB clock input:
 - 7-frequency internal bus clock prescaler selection
 - External TIMB clock input (4-MHz maximum frequency)
- Free-running or modulo up-count operation
- Toggle any channel pin on overflow
- TIMB counter stop and reset bits

17.3 Functional Description

Figure 17-2 shows the TIMB structure. The central component of the TIMB is the 16-bit TIMB counter that can operate as a free-running counter or a modulo up-counter. The TIMB counter provides the timing reference for the input capture and output compare functions. The TIMB counter modulo registers, TBMODH–TBMODL, control the modulo value of the TIMB counter. Software can read the TIMB counter value at any time without affecting the counting sequence.

The two TIMB channels are programmable independently as input capture or output compare channels.

NOTE: *The TIMB module is not available in the 56-pin SDIP.*

Timer Interface B (TIMB)

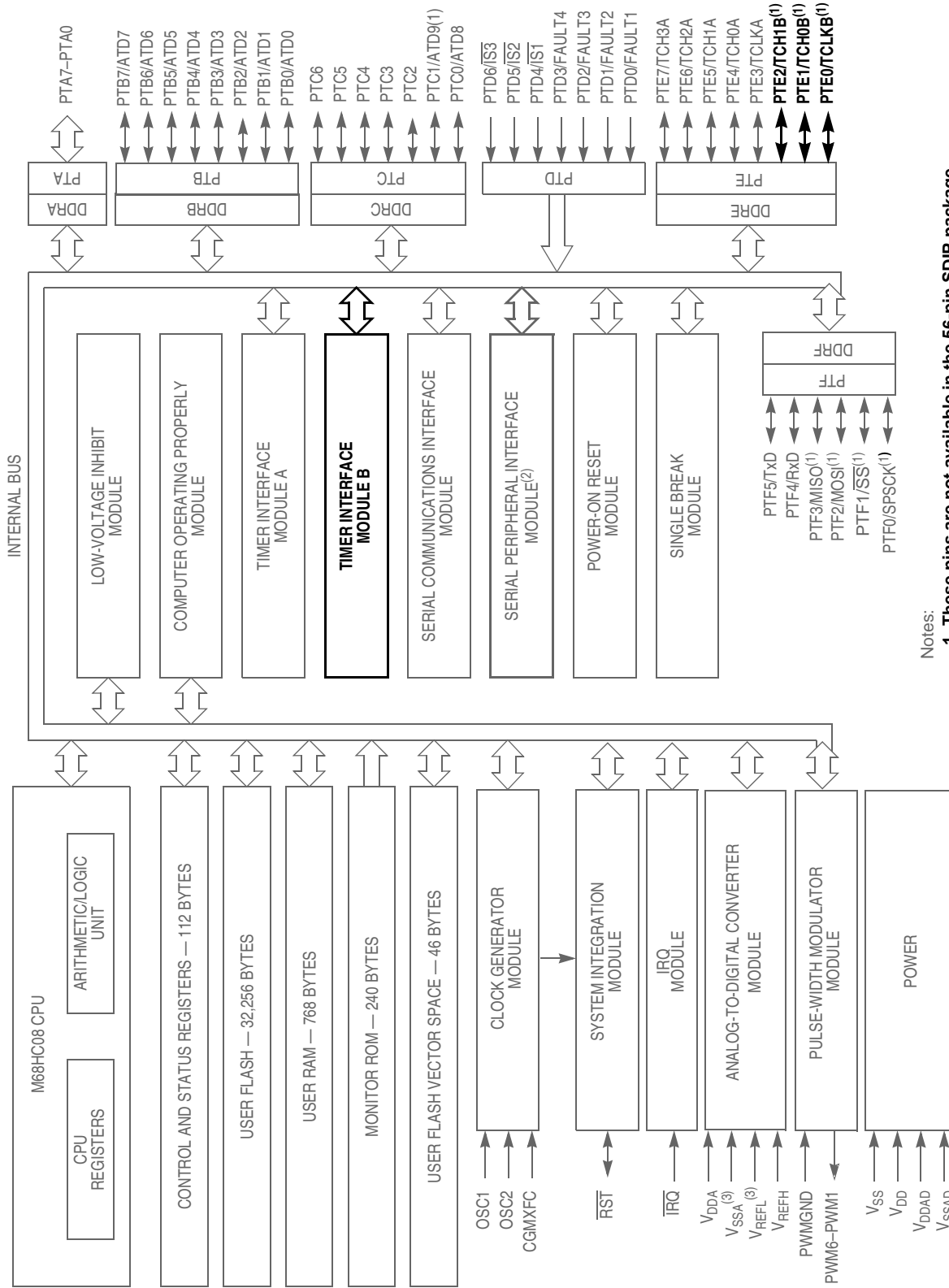

- Notes:
1. These pins are not available in the 56-pin SDIP package.
 2. This module is not available in the 56-pin SDIP package.
 3. In the 56-pin SDIP package, these pins are bonded together.

Figure 17-1. Block Diagram Highlighting TIMB Block and Pins

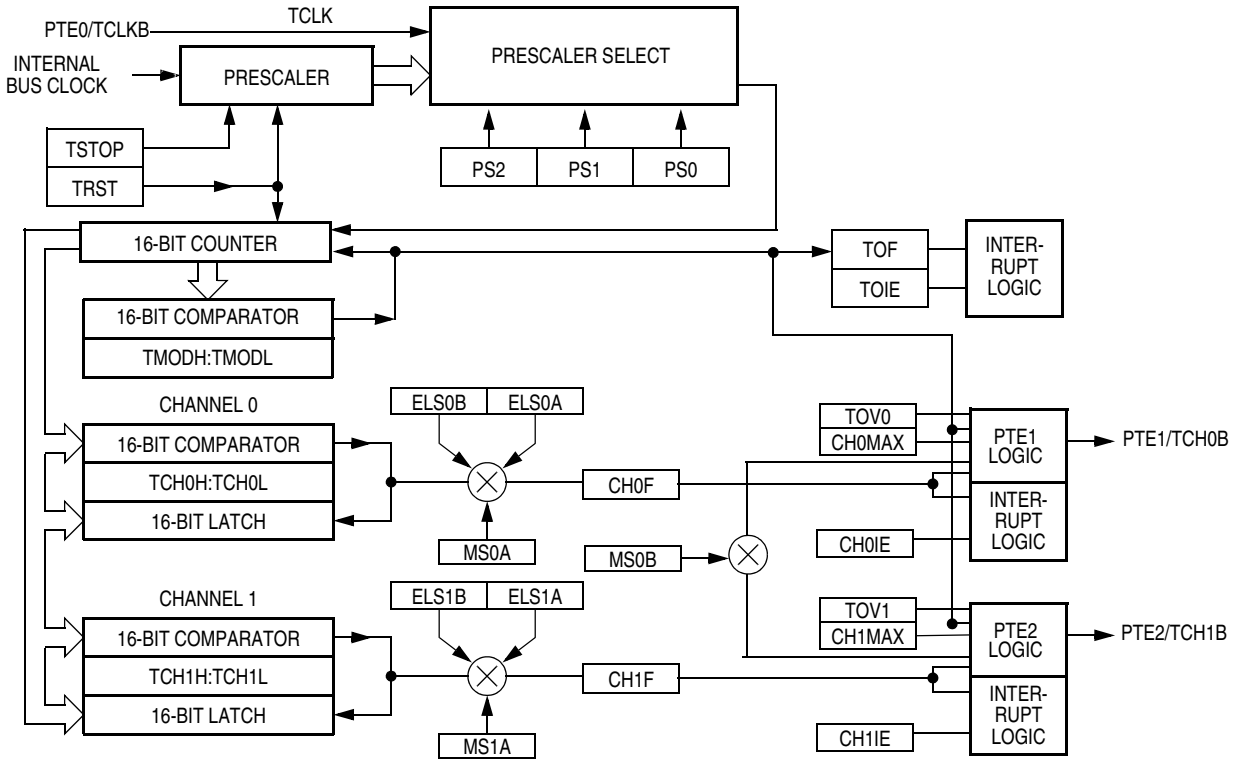

Figure 17-2. TIMB Block Diagram

Addr.	Register Name	Bit 7	6	5	4	3	2	1	Bit 0	
\$0051	TIMB Status/Control Register (TBSC) See page 265.	Read:	TOF	TOIE	TSTOP	0	0	PS2	PS1	PS0
		Write:	0			TRST	R			
		Reset:	0	0	1	0	0	0	0	0
\$0052	TIMB Counter Register High (TBCNTH) See page 267.	Read:	Bit 15	Bit 14	Bit 13	Bit 12	Bit 11	Bit 10	Bit 9	Bit 8
		Write:	R	R	R	R	R	R	R	R
		Reset:	0	0	0	0	0	0	0	0
\$0053	TIMB Counter Register Low (TBCNTL) See page 267.	Read:	Bit 7	Bit 6	Bit 5	Bit 4	Bit 3	Bit 2	Bit 1	Bit 0
		Write:	R	R	R	R	R	R	R	R
		Reset:	0	0	0	0	0	0	0	0
\$0054	TIMB Counter Modulo Register High (TBMODH) See page 268.	Read:	Bit 15	Bit 14	Bit 13	Bit 12	Bit 11	Bit 10	Bit 9	Bit 8
		Write:	Bit 15	Bit 14	Bit 13	Bit 12	Bit 11	Bit 10	Bit 9	Bit 8
		Reset:	1	1	1	1	1	1	1	1

R = Reserved

Figure 17-3. TIMB I/O Register Summary

Timer Interface B (TIMB)

Addr.	Register Name	Bit 7	6	5	4	3	2	1	Bit 0	
\$0055	TIMB Counter Modulo Register Low (TBMODL) See page 268.	Read:	Bit 7	Bit 6	Bit 5	Bit 4	Bit 3	Bit 2	Bit 1	Bit 0
		Write:	Bit 7	Bit 6	Bit 5	Bit 4	Bit 3	Bit 2	Bit 1	Bit 0
		Reset:	1	1	1	1	1	1	1	1
\$0056	TIMB Channel 0 Status/Control Register (TBSC0) See page 269.	Read:	CH0F	CH0IE	MS0B	MS0A	ELS0B	ELS0A	TOV0	CH0MAX
		Write:	0	CH0IE	MS0B	MS0A	ELS0B	ELS0A	TOV0	CH0MAX
		Reset:	0	0	0	0	0	0	0	0
\$0057	TIMB Channel 0 Register High (TBCH0H) See page 272.	Read:	Bit 15	Bit 14	Bit 13	Bit 12	Bit 11	Bit 10	Bit 9	Bit 8
		Write:	Bit 15	Bit 14	Bit 13	Bit 12	Bit 11	Bit 10	Bit 9	Bit 8
		Reset:	Indeterminate after reset							
\$0058	TIMB Channel 0 Register Low (TBCH0L) See page 272.	Read:	Bit 7	Bit 6	Bit 5	Bit 4	Bit 3	Bit 2	Bit 1	Bit 0
		Write:	Bit 7	Bit 6	Bit 5	Bit 4	Bit 3	Bit 2	Bit 1	Bit 0
		Reset:	Indeterminate after reset							
\$0059	TIMB Channel 1 Status/Control Register (TBSC1) See page 269.	Read:	CH1F	CH1IE	0	MS1A	ELS1B	ELS1A	TOV1	CH1MAX
		Write:	0	CH1IE	R	MS1A	ELS1B	ELS1A	TOV1	CH1MAX
		Reset:	0	0	0	0	0	0	0	0
\$005A	TIMB Channel 1 Register High (TBCH1H) See page 272.	Read:	Bit 15	Bit 14	Bit 13	Bit 12	Bit 11	Bit 10	Bit 9	Bit 8
		Write:	Bit 15	Bit 14	Bit 13	Bit 12	Bit 11	Bit 10	Bit 9	Bit 8
		Reset:	Indeterminate after reset							
\$005B	TIMB Channel 1 Register Low (TBCH1L) See page 272.	Read:	Bit 7	Bit 6	Bit 5	Bit 4	Bit 3	Bit 2	Bit 1	Bit 0
		Write:	Bit 7	Bit 6	Bit 5	Bit 4	Bit 3	Bit 2	Bit 1	Bit 0
		Reset:	Indeterminate after reset							

R = Reserved

Figure 17-3. TIMB I/O Register Summary (Continued)

17.3.1 TIMB Counter Prescaler

The TIMB clock source can be one of the seven prescaler outputs or the TIMB clock pin, PTE0/TCLKB. The prescaler generates seven clock rates from the internal bus clock. The prescaler select bits, PS[2:0], in the TIMB status and control register select the TIMB clock source.

17.3.2 Input Capture

An input capture function has three basic parts:

1. Edge select logic
2. Input capture latch
3. 16-bit counter

Two 8-bit registers, which make up the 16-bit input capture register, are used to latch the value of the free-running counter after the corresponding input capture edge detector senses a defined transition. The polarity of the active edge is

programmable. The level transition which triggers the counter transfer is defined by the corresponding input edge bits (ELSxB and ELSxA in TBSC0–TBSC1 control registers with x referring to the active channel number). When an active edge occurs on the pin of an input capture channel, the TIMB latches the contents of the TIMB counter into the TIMB channel registers, TCHxH–TCHxL. Input captures can generate TIMB CPU interrupt requests. Software can determine that an input capture event has occurred by enabling input capture interrupts or by polling the status flag bit.

The free-running counter contents are transferred to the TIMB channel status and control register (TBCHxH–TBCHxL, see [17.7.5 TIMB Channel Registers](#)) on each proper signal transition regardless of whether the TIMB channel flag (CH0F–CH1F in TBSC0–TBSC1 registers) is set or clear. When the status flag is set, a CPU interrupt is generated if enabled. The value of the count latched or “captured” is the time of the event. Because this value is stored in the input capture register two bus cycles after the actual event occurs, user software can respond to this event at a later time and determine the actual time of the event. However, this must be done prior to another input capture on the same pin; otherwise, the previous time value will be lost.

By recording the times for successive edges on an incoming signal, software can determine the period and/or pulse width of the signal. To measure a period, two successive edges of the same polarity are captured. To measure a pulse width, two alternate polarity edges are captured. Software should track the overflows at the 16-bit module counter to extend its range.

Another use for the input capture function is to establish a time reference. In this case, an input capture function is used in conjunction with an output compare function. For example, to activate an output signal a specified number of clock cycles after detecting an input event (edge), use the input capture function to record the time at which the edge occurred. A number corresponding to the desired delay is added to this captured value and stored to an output compare register (see [17.7.5 TIMB Channel Registers](#)). Because both input captures and output compares are referenced to the same 16-bit modulo counter, the delay can be controlled to the resolution of the counter independent of software latencies.

Reset does not affect the contents of the input capture channel register (TBCHxH–TBCHxL).

17.3.3 Output Compare

With the output compare function, the TIMB can generate a periodic pulse with a programmable polarity, duration, and frequency. When the counter reaches the value in the registers of an output compare channel, the TIMB can set, clear, or toggle the channel pin. Output compares can generate TIMB CPU interrupt requests.

17.3.3.1 Unbuffered Output Compare

Any output compare channel can generate unbuffered output compare pulses as described in [17.3.3 Output Compare](#). The pulses are unbuffered because changing the output compare value requires writing the new value over the old value currently in the TIMB channel registers.

An unsynchronized write to the TIMB channel registers to change an output compare value could cause incorrect operation for up to two counter overflow periods. For example, writing a new value before the counter reaches the old value but after the counter reaches the new value prevents any compare during that counter overflow period. Also, using a TIMB overflow interrupt routine to write a new, smaller output compare value may cause the compare to be missed. The TIMB may pass the new value before it is written.

Use this method to synchronize unbuffered changes in the output compare value on channel x:

- When changing to a smaller value, enable channel x output compare interrupts and write the new value in the output compare interrupt routine. The output compare interrupt occurs at the end of the current output compare pulse. The interrupt routine has until the end of the counter overflow period to write the new value.
- When changing to a larger output compare value, enable TIMB overflow interrupts and write the new value in the TIMB overflow interrupt routine. The TIMB overflow interrupt occurs at the end of the current counter overflow period. Writing a larger value in an output compare interrupt routine (at the end of the current pulse) could cause two output compares to occur in the same counter overflow period.

17.3.3.2 Buffered Output Compare

Channels 0 and 1 can be linked to form a buffered output compare channel whose output appears on the PTE1/TCH0B pin. The TIMB channel registers of the linked pair alternately control the output.

Setting the MS0B bit in TIMB channel 0 status and control register (TBSC0) links channel 0 and channel 1. The output compare value in the TIMB channel 0 registers initially controls the output on the PTE1/TCH0B pin. Writing to the TIMB channel 1 registers enables the TIMB channel 1 registers to synchronously control the output after the TIMB overflows. At each subsequent overflow, the TIMB channel registers (0 or 1) that control the output are the ones written to last. TSC0 controls and monitors the buffered output compare function, and TIMB channel 1 status and control register (TBSC1) is unused. While the MS0B bit is set, the channel 1 pin, PTE2/TCH1B, is available as a general-purpose I/O pin.

NOTE: *In buffered output compare operation, do not write new output compare values to the currently active channel registers. User software should track the currently*

active channel to prevent writing a new value to the active channel. Writing to the active channel registers is the same as generating unbuffered output compares.

17.3.4 Pulse-Width Modulation (PWM)

By using the toggle-on-overflow feature with an output compare channel, the TIMB can generate a PWM signal. The value in the TIMB counter modulo registers determines the period of the PWM signal. The channel pin toggles when the counter reaches the value in the TIMB counter modulo registers. The time between overflows is the period of the PWM signal.

As **Figure 17-4** shows, the output compare value in the TIMB channel registers determines the pulse width of the PWM signal. The time between overflow and output compare is the pulse width. Program the TIMB to clear the channel pin on output compare if the polarity of the PWM pulse is 1 (ELSxA = 0). Program the TIMB to set the pin if the polarity of the PWM pulse is 0 (ELSxA = 1).

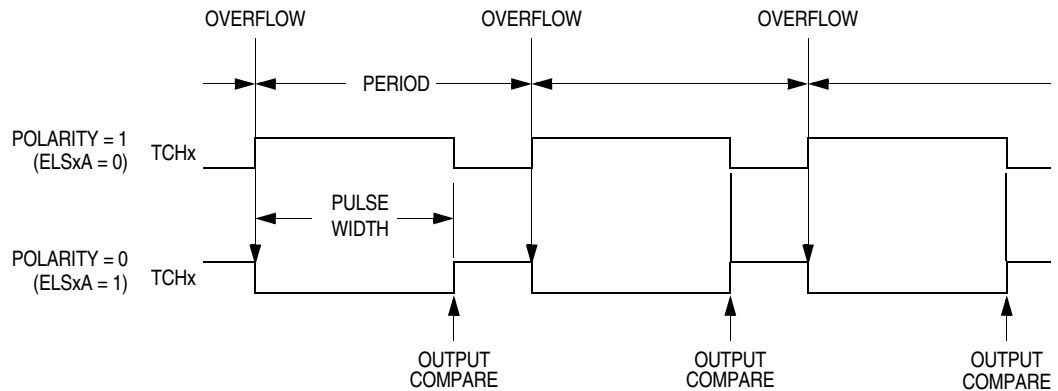

Figure 17-4. PWM Period and Pulse Width

The value in the TIMB counter modulo registers and the selected prescaler output determines the frequency of the PWM output. The frequency of an 8-bit PWM signal is variable in 256 increments. Writing \$00FF (255) to the TIMB counter modulo registers produces a PWM period of 256 times the internal bus clock period if the prescaler select value is \$000 (see **17.7.1 TIMB Status and Control Register**).

The value in the TIMB channel registers determines the pulse width of the PWM output. The pulse width of an 8-bit PWM signal is variable in 256 increments. Writing \$0080 (128) to the TIMB channel registers produces a duty cycle of 128/256 or 50 percent.

17.3.4.1 Unbuffered PWM Signal Generation

Any output compare channel can generate unbuffered PWM pulses as described in [17.3.4 Pulse-Width Modulation \(PWM\)](#). The pulses are unbuffered because changing the pulse width requires writing the new pulse width value over the value currently in the TIMB channel registers.

An unsynchronized write to the TIMB channel registers to change a pulse width value could cause incorrect operation for up to two PWM periods. For example, writing a new value before the counter reaches the old value but after the counter reaches the new value prevents any compare during that PWM period. Also, using a TIMB overflow interrupt routine to write a new, smaller pulse width value may cause the compare to be missed. The TIMB may pass the new value before it is written to the TIMB channel registers.

Use this method to synchronize unbuffered changes in the PWM pulse width on channel x:

- When changing to a shorter pulse width, enable channel x output compare interrupts and write the new value in the output compare interrupt routine. The output compare interrupt occurs at the end of the current pulse. The interrupt routine has until the end of the PWM period to write the new value.
- When changing to a longer pulse width, enable TIMB overflow interrupts and write the new value in the TIMB overflow interrupt routine. The TIMB overflow interrupt occurs at the end of the current PWM period. Writing a larger value in an output compare interrupt routine (at the end of the current pulse) could cause two output compares to occur in the same PWM period.

NOTE: *In PWM signal generation, do not program the PWM channel to toggle on output compare. Toggling on output compare prevents reliable 0 percent duty cycle generation and removes the ability of the channel to self-correct in the event of software error or noise. Toggling on output compare also can cause incorrect PWM signal generation when changing the PWM pulse width to a new, much larger value.*

17.3.4.2 Buffered PWM Signal Generation

Channels 0 and 1 can be linked to form a buffered PWM channel whose output appears on the PTE1/TCH0B pin. The TIMB channel registers of the linked pair alternately control the pulse width of the output.

Setting the MS0B bit in TIMB channel 0 status and control register (TBSC0) links channel 0 and channel 1. The TIMB channel 0 registers initially control the pulse width on the PTE1/TCH0B pin. Writing to the TIMB channel 1 registers enables the TIMB channel 1 registers to synchronously control the pulse width at the beginning of the next PWM period. At each subsequent overflow, the TIMB channel registers (0 or 1) that control the pulse width are the ones written to last. TBSC0 controls and monitors the buffered PWM function, and TIMB channel 1 status and control

register (TBSC1) is unused. While the MS0B bit is set, the channel 1 pin, PTE2/TCH1B, is available as a general-purpose I/O pin.

NOTE: *In buffered PWM signal generation, do not write new pulse width values to the currently active channel registers. User software should track the currently active channel to prevent writing a new value to the active channel. Writing to the active channel registers is the same as generating unbuffered PWM signals.*

17.3.4.3 PWM Initialization

To ensure correct operation when generating unbuffered or buffered PWM signals, use this initialization procedure:

1. In the TIMB status and control register (TBSC):
 - a. Stop the TIMB counter by setting the TIMB stop bit, TSTOP.
 - b. Reset the TIMB counter and prescaler by setting the TIMB reset bit, TRST.
2. In the TIMB counter modulo registers (TBMODH–TBMODL), write the value for the required PWM period.
3. In the TIMB channel x registers (TBCHxH–TBCHxL), write the value for the required pulse width.
4. In TIMB channel x status and control register (TBSCx):
 - a. Write 0:1 (for unbuffered output compare or PWM signals) or 1:0 (for buffered output compare or PWM signals) to the mode select bits, MSxB–MSxA. (See [Table 17-2](#).)
 - b. Write 1 to the toggle-on-overflow bit, TOVx.
 - c. Write 1:0 (polarity 1 — to clear output on compare) or 1:1 (polarity 0 — to set output on compare) to the edge/level select bits, ELSxB–ELSxA. The output action on compare must force the output to the complement of the pulse width level. (See [Table 17-2](#).)

NOTE: *In PWM signal generation, do not program the PWM channel to toggle on output compare. Toggling on output compare prevents reliable 0 percent duty cycle generation and removes the ability of the channel to self-correct in the event of software error or noise. Toggling on output compare can also cause incorrect PWM signal generation when changing the PWM pulse width to a new, much larger value.*

5. In the TIMB status control register (TBSC), clear the TIMB stop bit, TSTOP.

Setting MS0B links channels 0 and 1 and configures them for buffered PWM operation. The TIMB channel 0 registers (TBCH0H–TBCH0L) initially control the buffered PWM output. TIMB status control register 0 (TBSC0) controls and monitors the PWM signal from the linked channels. MS0B takes priority over MS0A.

Clearing the toggle-on-overflow bit, TOVx, inhibits output toggles on TIMB overflows. Subsequent output compares try to force the output to a state it is already in and have no effect. The result is a 0 percent duty cycle output.

Setting the channel x maximum duty cycle bit (CHxMAX) and setting the TOVx bit generates a 100 percent duty cycle output. (See [17.7.4 TIMB Channel Status and Control Registers](#).)

17.4 Interrupts

These TIMB sources can generate interrupt requests:

- TIMB overflow flag (TOF) — The timer overflow flag (TOF) bit is set when the TIMB counter reaches the modulo value programmed in the TIMB counter modulo registers. The TIMB overflow interrupt enable bit, TOIE, enables TIMB overflow interrupt requests. TOF and TOIE are in the TIMB status and control registers.
- TIMB channel flags (CH1F–CH0F) — The CHxF bit is set when an input capture or output compare occurs on channel x. Channel x TIMB CPU interrupt requests are controlled by the channel x interrupt enable bit, CHxIE.

17.5 Wait Mode

The WAIT instruction puts the MCU in low-power standby mode.

The TIMB remains active after the execution of a WAIT instruction. In wait mode, the TIMB registers are not accessible by the CPU. Any enabled CPU interrupt request from the TIMB can bring the MCU out of wait mode.

If TIMB functions are not required during wait mode, reduce power consumption by stopping the TIMB before executing the WAIT instruction.

17.6 I/O Signals

Port E shares three of its pins with the TIMB:

- PTE0/TCLKB is an external clock input to the TIMB prescaler.
- The two TIMB channel I/O pins are PTE1/TCH0B and PTE2/TCH1B.

17.6.1 TIMB Clock Pin (PTE0/TCLKB)

PTE0/TCLKB is an external clock input that can be the clock source for the TIMB counter instead of the prescaled internal bus clock. Select the PTE0/TCLKB input by writing 1s to the three prescaler select bits, PS[2:0]. See [17.7.1 TIMB Status and Control Register](#).

The maximum TCLK frequency is the least: 4 MHz or bus frequency ÷ 2.

PTE0/TCLKB is available as a general-purpose I/O pin or ADC channel when not used as the TIMB clock input. When the PTE0/TCLKB pin is the TIMB clock input, it is an input regardless of the state of the DDRE0 bit in data direction register E.

17.6.2 TIMB Channel I/O Pins (PTE1/TCH0B–PTE2/TCH1B)

Each channel I/O pin is programmable independently as an input capture pin or an output compare pin. PTE1/TCH0B and PTE2/TCH1B can be configured as buffered output compare or buffered PWM pins.

17.7 I/O Registers

These input/output (I/O) registers control and monitor TIMB operation:

- TIMB status and control register (TBSC)
- TIMB control registers (TBCNTH–TBCNTL)
- TIMB counter modulo registers (TBMODH–TBMODL)
- TIMB channel status and control registers (TBSC0 and TBSC1)
- TIMB channel registers (TBCH0H–TBCH0L and TBCH1H–TBCH1L)

17.7.1 TIMB Status and Control Register

The TIMB status and control register:

- Enables TIMB overflow interrupts
- Flags TIMB overflows
- Stops the TIMB counter
- Resets the TIMB counter
- Prescales the TIMB counter clock

Address: \$0051

	Bit 7	6	5	4	3	2	1	Bit 0
Read:	TOF	TOIE	TSTOP	0	0	PS2	PS1	PS0
Write:	0			TRST	R			
Reset:	0	0	1	0	0	0	0	0

R = Reserved

Figure 17-5. TIMB Status and Control Register (TBSC)

TOF — TIMB Overflow Flag

This read/write flag is set when the TIMB counter reaches the modulo value programmed in the TIMB counter modulo registers. Clear TOF by reading the TIMB status and control register when TOF is set and then writing a logic 0 to TOF. If another TIMB overflow occurs before the clearing sequence is complete,

then writing logic 0 to TOF has no effect. Therefore, a TOF interrupt request cannot be lost due to inadvertent clearing of TOF. Reset clears the TOF bit. Writing a logic 1 to TOF has no effect.

1 = TIMB counter has reached modulo value.

0 = TIMB counter has not reached modulo value.

TOIE — TIMB Overflow Interrupt Enable Bit

This read/write bit enables TIMB overflow interrupts when the TOF bit becomes set. Reset clears the TOIE bit.

1 = TIMB overflow interrupts enabled

0 = TIMB overflow interrupts disabled

TSTOP — TIMB Stop Bit

This read/write bit stops the TIMB counter. Counting resumes when TSTOP is cleared. Reset sets the TSTOP bit, stopping the TIMB counter until software clears the TSTOP bit.

1 = TIMB counter stopped

0 = TIMB counter active

NOTE: Do not set the TSTOP bit before entering wait mode if the TIMB is required to exit wait mode. Also, when the TSTOP bit is set and the timer is configured for input capture operation, input captures are inhibited until TSTOP is cleared.

TRST — TIMB Reset Bit

Setting this write-only bit resets the TIMB counter and the TIMB prescaler. Setting TRST has no effect on any other registers. Counting resumes from \$0000. TRST is cleared automatically after the TIMB counter is reset and always reads as logic 0. Reset clears the TRST bit.

1 = Prescaler and TIMB counter cleared

0 = No effect

NOTE: Setting the TSTOP and TRST bits simultaneously stops the TIMB counter at a value of \$0000.

PS[2:0] — Prescaler Select Bits

These read/write bits select either the PTE0/TCLKB pin or one of the seven prescaler outputs as the input to the TIMB counter as [Table 17-1](#) shows. Reset clears the PS[2:0] bits.

Table 17-1. Prescaler Selection

PS[2:0]	TIMB Clock Source
000	Internal bus clock ÷ 1
001	Internal bus clock ÷ 2
010	Internal bus clock ÷ 4
011	Internal bus clock ÷ 8
100	Internal bus clock ÷ 16
101	Internal bus clock ÷ 32
110	Internal bus clock ÷ 64
111	PTE0/TCLKB

17.7.2 TIMB Counter Registers

The two read-only TIMB counter registers contain the high and low bytes of the value in the TIMB counter. Reading the high byte (TBCNTH) latches the contents of the low byte (TBCNTL) into a buffer. Subsequent reads of TBCNTH do not affect the latched TBCNTL value until TBCNTL is read. Reset clears the TIMB counter registers. Setting the TIMB reset bit (TRST) also clears the TIMB counter registers.

NOTE: *If TBCNTH is read during a break interrupt, be sure to unlatch TBCNTL by reading TBCNTL before exiting the break interrupt. Otherwise, TBCNTL retains the value latched during the break.*

Register Name and Address: TBCNTH — \$0052

	Bit 7	6	5	4	3	2	1	Bit 0
Read:	Bit 15	Bit 14	Bit 13	Bit 12	Bit 11	Bit 10	Bit 9	Bit 8
Write:	R	R	R	R	R	R	R	R
Reset:	0	0	0	0	0	0	0	0

Register Name and Address: TBCNTL — \$0053

	Bit 7	6	5	4	3	2	1	Bit 0
Read:	Bit 7	Bit 6	Bit 5	Bit 4	Bit 3	Bit 2	Bit 1	Bit 0
Write:	R	R	R	R	R	R	R	R
Reset:	0	0	0	0	0	0	0	0

R

 = Reserved

Figure 17-6. TIMB Counter Registers (TBCNTH and TBCNTL)

17.7.3 TIMB Counter Modulo Registers

The read/write TIMB modulo registers contain the modulo value for the TIMB counter. When the TIMB counter reaches the modulo value, the overflow flag (TOF) becomes set, and the TIMB counter resumes counting from \$0000 at the next timer clock. Writing to the high byte (TBMODH) inhibits the TOF bit and overflow interrupts until the low byte (TBMODL) is written. Reset sets the TIMB counter modulo registers.

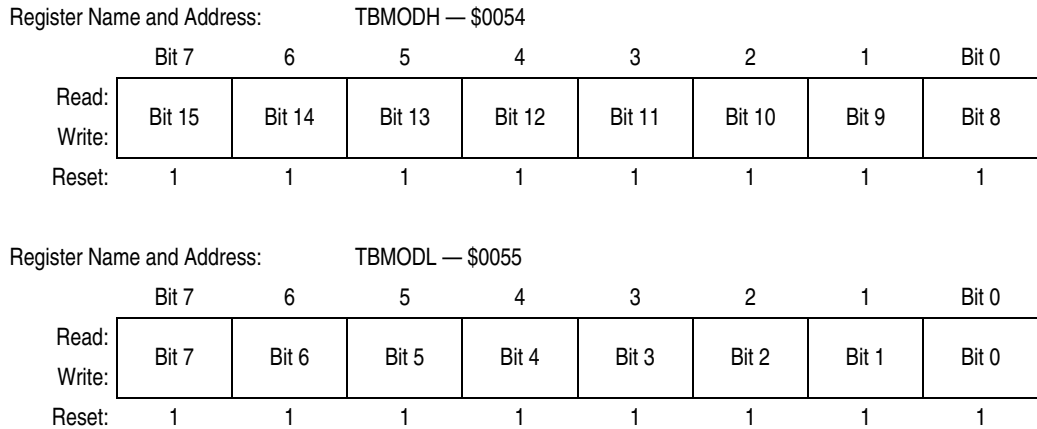

Figure 17-7. TIMB Counter Modulo Registers (TBMODH and TBMODL)

NOTE: Reset the TIMB counter before writing to the TIMB counter modulo registers.

17.7.4 TIMB Channel Status and Control Registers

Each of the TIMB channel status and control registers:

- Flags input captures and output compares
- Enables input capture and output compare interrupts
- Selects input capture, output compare, or PWM operation
- Selects high, low, or toggling output on output compare
- Selects rising edge, falling edge, or any edge as the active input capture trigger
- Selects output toggling on TIMB overflow
- Selects 0 percent and 100 percent PWM duty cycle
- Selects buffered or unbuffered output compare/PWM operation

Register Name and Address:		TBSC0 — \$0056							
		Bit 7	6	5	4	3	2	1	Bit 0
Read:	CH0F	CH0IE	MS0B	MS0A	ELS0B	ELS0A	TOV0	CH0MAX	
Write:	0								
Reset:	0	0	0	0	0	0	0	0	0

Register Name and Address:		TBSC1 — \$0059							
		Bit 7	6	5	4	3	2	1	Bit 0
Read:	CH1F	CH1IE	0	MS1A	ELS1B	ELS1A	TOV1	CH1MAX	
Write:	0		R						
Reset:	0	0	0	0	0	0	0	0	0

R

 = Reserved

Figure 17-8. TIMB Channel Status and Control Registers (TBSC0–TBSC1)

CHxF — Channel x Flag

When channel x is an input capture channel, this read/write bit is set when an active edge occurs on the channel x pin. When channel x is an output compare channel, CHxF is set when the value in the TIMB counter registers matches the value in the TIMB channel x registers.

When CHxIE = 1, clear CHxF by reading TIMB channel x status and control register with CHxF set, and then writing a 0 to CHxF. If another interrupt request occurs before the clearing sequence is complete, then writing 0 to CHxF has no effect. Therefore, an interrupt request cannot be lost due to inadvertent clearing of CHxF.

Reset clears the CHxF bit. Writing a 1 to CHxF has no effect.

- 1 = Input capture or output compare on channel x
- 0 = No input capture or output compare on channel x

CHxIE — Channel x Interrupt Enable Bit

This read/write bit enables TIMB CPU interrupts on channel x.

Reset clears the CHxIE bit.

- 1 = Channel x CPU interrupt requests enabled
- 0 = Channel x CPU interrupt requests disabled

MSxB — Mode Select Bit B

This read/write bit selects buffered output compare/PWM operation. MSxB exists only in the TIMB channel 0.

Setting MS0B disables the channel 1 status and control register and reverts TCH1B to general-purpose I/O.

Reset clears the MSxB bit.

- 1 = Buffered output compare/PWM operation enabled
- 0 = Buffered output compare/PWM operation disabled

MSxA — Mode Select Bit A

When ELSxB:A \neq 00, this read/write bit selects either input capture operation or unbuffered output compare/PWM operation. See [Table 17-2](#).

1 = Unbuffered output compare/PWM operation

0 = Input capture operation

When ELSxB:A = 00, this read/write bit selects the initial output level of the TCHx pin once PWM, input capture, or output compare operation is enabled. See [Table 17-2](#). Reset clears the MSxA bit.

1 = Initial output level low

0 = Initial output level high

NOTE: Before changing a channel function by writing to the MSxB or MSxA bit, set the TSTOP and TRST bits in the TIMB status and control register (TBSC).

ELSxB and ELSxA — Edge/Level Select Bits

When channel x is an input capture channel, these read/write bits control the active edge-sensing logic on channel x.

When channel x is an output compare channel, ELSxB and ELSxA control the channel x output behavior when an output compare occurs.

When ELSxB and ELSxA are both clear, channel x is not connected to port E, and pin PTE_x/TCH_xB is available as a general-purpose I/O pin. However, channel x is at a state determined by these bits and becomes transparent to the respective pin when PWM, input capture, or output compare mode is enabled. [Table 17-2](#) shows how ELSxB and ELSxA work. Reset clears the ELSxB and ELSxA bits.

NOTE: Before enabling a TIMB channel register for input capture operation, make sure that the PTE_x/TBCH_x pin is stable for at least two bus clocks.

TOVx — Toggle-On-Overflow Bit

When channel x is an output compare channel, this read/write bit controls the behavior of the channel x output when the TIMB counter overflows. When channel x is an input capture channel, TOVx has no effect. Reset clears the TOVx bit.

1 = Channel x pin toggles on TIMB counter overflow.

0 = Channel x pin does not toggle on TIMB counter overflow.

Table 17-2. Mode, Edge, and Level Selection

MSxB:MSxA	ELSxB:ELSxA	Mode	Configuration
X0	00	Output preset	Pin under port control; initialize timer output level high
X1	00		Pin under port control; initialize timer output level low
00	01	Input capture	Capture on rising edge only
00	10		Capture on falling edge only
00	11		Capture on rising or falling edge
01	00	Output compare or PWM	Software compare only
01	01		Toggle output on compare
01	10		Clear output on compare
01	11		Set output on compare
1X	01	Buffered output compare or buffered PWM	Toggle output on compare
1X	10		Clear output on compare
1X	11		Set output on compare

NOTE: When TOVx is set, a TIMB counter overflow takes precedence over a channel x output compare if both occur at the same time.

CHxMAX — Channel x Maximum Duty Cycle Bit

When the TOVx is 1 and clear output on compare is selected, setting the CHxMAX bit forces the duty cycle of buffered and unbuffered PWM signals to 100 percent. As Figure 17-9 shows, CHxMAX bit takes effect in the cycle after it is set or cleared. The output stays at 100 percent duty cycle level until the cycle after CHxMAX is cleared.

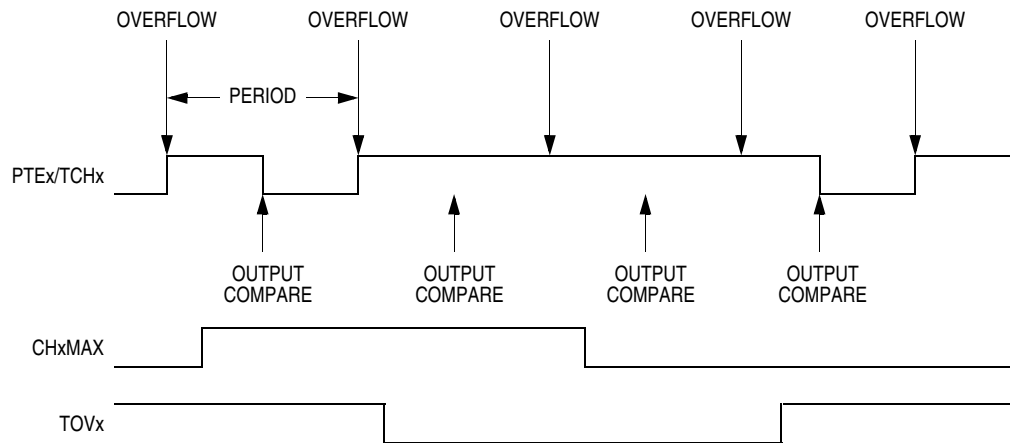

Figure 17-9. CHxMAX Latency

17.7.5 TIMB Channel Registers

These read/write registers contain the captured TIMB counter value of the input capture function or the output compare value of the output compare function. The state of the TIMB channel registers after reset is unknown.

In input capture mode (MSxB–MSxA = 0:0), reading the high byte of the TIMB channel x registers (TBCHxH) inhibits input captures until the low byte (TBCHxL) is read.

In output compare mode (MSxB–MSxA ≠ 0:0), writing to the high byte of the TIMB channel x registers (TBCHxH) inhibits output compares until the low byte (TBCHxL) is written.

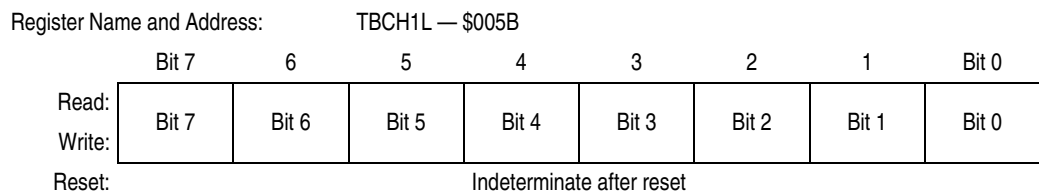
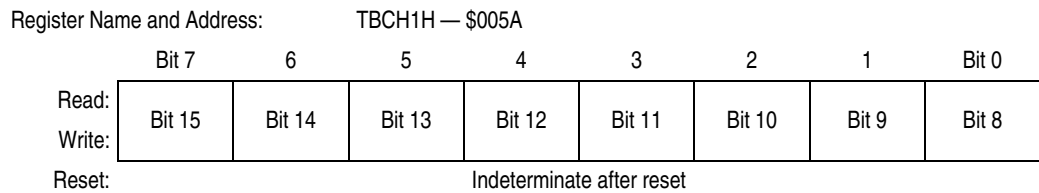
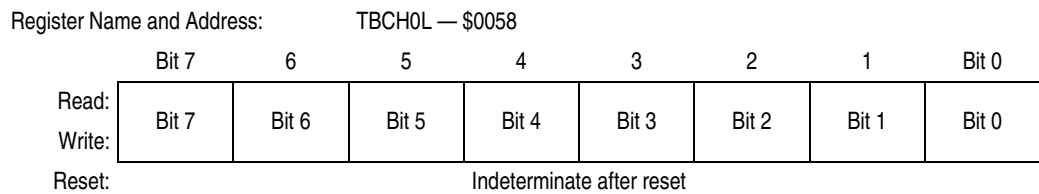
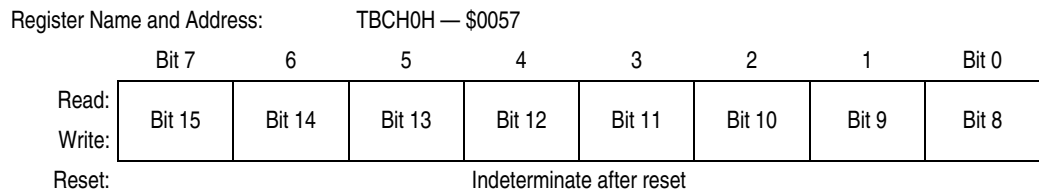

Figure 17-10. TIMB Channel Registers (TBCH0H/L–TBCH1H/L)

Section 18. Development Support

18.1 Introduction

This section describes the break module, the monitor read-only memory (MON), and the monitor mode entry methods.

18.2 Break Module (BRK)

The break module (BRK) can generate a break interrupt that stops normal program flow at a defined address to enter a background program. Features include:

- Accessible input/output (I/O) registers during the break interrupt
- Central processor unit (CPU) generated break interrupts
- Software-generated break interrupts
- Computer operating properly (COP) disabling during break interrupts

18.2.1 Functional Description

When the internal address bus matches the value written in the break address registers, the break module issues a breakpoint signal to the CPU. The CPU then loads the instruction register with a software interrupt instruction (SWI) after completion of the current CPU instruction. The program counter vectors to \$FFFC and \$FFFD (\$FEFC and \$FEFD in monitor mode).

These events can cause a break interrupt to occur:

- A CPU-generated address (the address in the program counter) matches the contents of the break address registers.
- Software writes a logic 1 to the BRKA bit in the break status and control register.

When a CPU-generated address matches the contents of the break address registers, the break interrupt begins after the CPU completes its current instruction. A return-from-interrupt instruction (RTI) in the break routine ends the break interrupt and returns the microcontroller unit (MCU) to normal operation.

Figure 18-1 shows the structure of the break module.

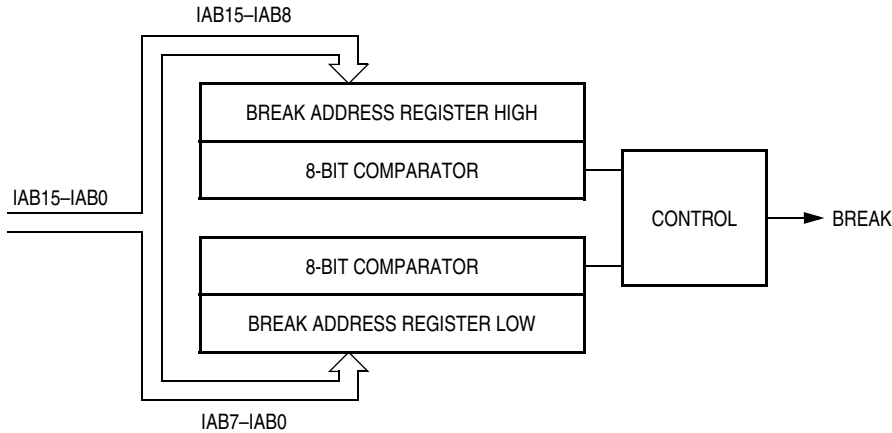

Figure 18-1. Break Module Block Diagram

Addr.	Register Name	Bit 7	6	5	4	3	2	1	Bit 0		
\$FE00	SIM Break Status Register (SBSR) See page 277.	Read:	R	R	R	R	R	BW	R		
		Write:									
		Reset:								0	
\$FE03	SIM Break Flag Control Register (SBFCR) See page 278.	Read:	BCFE	R	R	R	R	R	R		
		Write:									
		Reset:	0								
\$FE0C	Break Address Register High (BRKH) See page 276.	Read:	Bit 15	14	13	12	11	10	9	Bit 8	
		Write:									
		Reset:	0	0	0	0	0	0	0	0	0
\$FE0D	Break Address Register Low (BRKL) See page 276.	Read:	Bit 7	6	5	4	3	2	1	Bit 0	
		Write:									
		Reset:	0	0	0	0	0	0	0	0	0
\$FE0E	Break Status and Control Register (BRKSCR) See page 276.	Read:	BRKE	BRKA	0	0	0	0	0	0	
		Write:									
		Reset:	0	0	0	0	0	0	0	0	0

Note: Writing a 0 clears BW.

= Unimplemented
 R = Reserved

Figure 18-2. I/O Register Summary

18.2.1.1 Flag Protection During Break Interrupts

The BCFE bit in the SIM break flag control register (SBFCR) enables software to clear status bits during the break state.

18.2.1.2 CPU During Break Interrupts

The CPU starts a break interrupt by:

- Loading the instruction register with the SWI instruction
- Loading the program counter with \$FFFC and \$FFFD (\$FEFC and \$FEFD in monitor mode)

The break interrupt begins after completion of the CPU instruction in progress. If the break address register match occurs on the last cycle of a CPU instruction, the break interrupt begins immediately.

18.2.1.3 TIM1 and TIM2 During Break Interrupts

A break interrupt stops the timer counters.

18.2.1.4 COP During Break Interrupts

The COP is disabled during a break interrupt when V_{TST} is present on the \overline{RST} pin.

18.2.2 Low-Power Modes

The WAIT and STOP instructions put the MCU in low power- consumption standby modes.

18.2.2.1 Wait Mode

If enabled, the break module is active in wait mode. In the break routine, the user can subtract one from the return address on the stack if SBSW is set. Clear the BW bit by writing logic 0 to it.

18.2.2.2 Stop Mode

The break module is inactive in stop mode. The STOP instruction does not affect break module register states.

18.2.3 Break Module Registers

These registers control and monitor operation of the break module:

- Break status and control register (BRKSCR)
- Break address register high (BRKH)
- Break address register low (BRKL)
- SIM break status register (SBSR)
- SIM break flag control register (SBFCR)

18.2.3.1 Break Status and Control Register

The break status and control register (BRKSCR) contains break module enable and status bits.

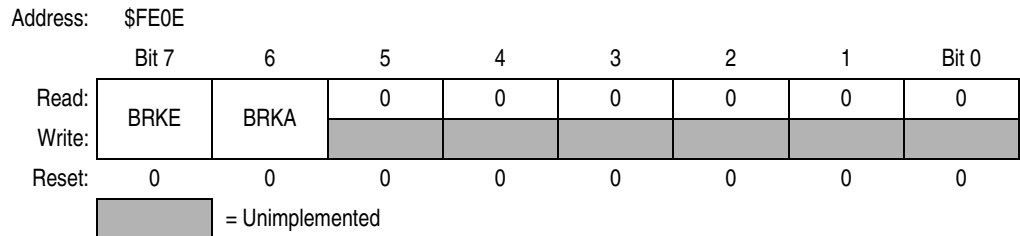

Figure 18-3. Break Status and Control Register (BRKSCR)

BRKE — Break Enable Bit

This read/write bit enables breaks on break address register matches. Clear BRKE by writing a logic 0 to bit 7. Reset clears the BRKE bit.

- 1 = Breaks enabled on 16-bit address match
- 0 = Breaks disabled on 16-bit address match

BRKA — Break Active Bit

This read/write status and control bit is set when a break address match occurs. Writing a logic 1 to BRKA generates a break interrupt. Clear BRKA by writing a logic 0 to it before exiting the break routine. Reset clears the BRKA bit.

- 1 = When read, break address match
- 0 = When read, no break address match

18.2.3.2 Break Address Registers

The break address registers (BRKH and BRKL) contain the high and low bytes of the desired breakpoint address. Reset clears the break address registers.

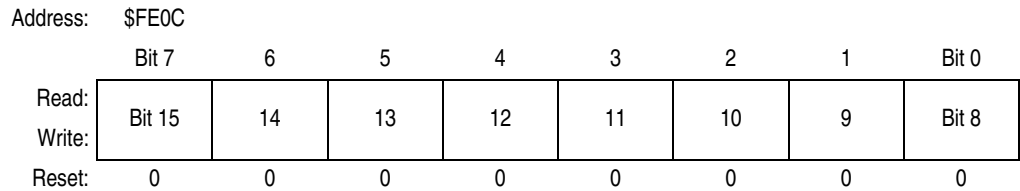

Figure 18-4. Break Address Register High (BRKH)

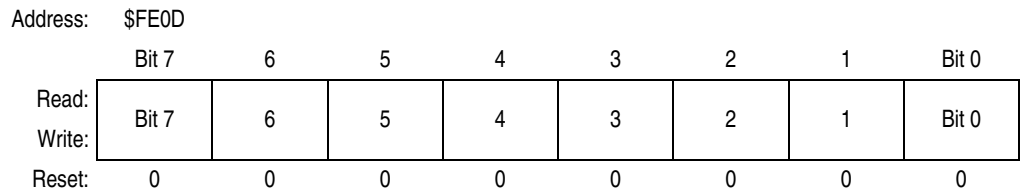

Figure 18-5. Break Address Register Low (BRKL)

18.2.3.3 Break Status Register

The break status register (SBSR) contains a flag to indicate that a break caused an exit from wait mode. The flag is useful in applications requiring a return to wait mode after exiting from a break interrupt.

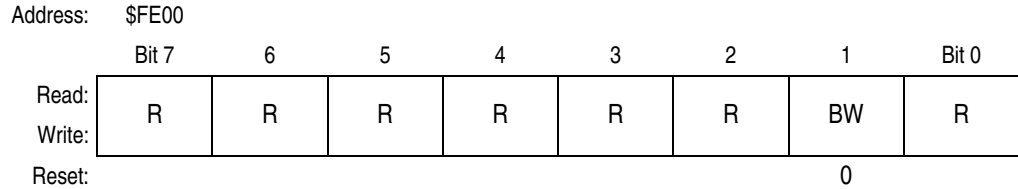

Figure 18-6. SIM Break Status Register (SBSR)

BW — Break Wait Bit

This read/write bit is set when a break interrupt causes an exit from wait mode. Clear BW by writing a logic 0 to it. Reset clears BW.

- 1 = Break interrupt during wait mode
- 0 = No break interrupt during wait mode

BW can be read within the break interrupt routine. The user can modify the return address on the stack by subtracting 1 from it. The following code is an example.

This code works if the H register was stacked in the break interrupt routine. Execute this code at the end of the break interrupt routine.

```

HIBYTE EQU 5
LOBYTE EQU 6

; If not BW, do RTI
BRCLR BW,BSR, RETURN ; See if wait mode or stop mode
; was exited by break.
TST LOBYTE,SP ; If RETURNLO is not 0,
BNE DOLO ; then just decrement low byte.
DEC HIBYTE,SP ; Else deal with high byte also.
DOLO DEC LOBYTE,SP ; Point to WAIT/STOP opcode.
RETURN PULH ; Restore H register.
RTI
    
```

18.2.3.4 Break Flag Control Register

The break flag control register (SBFCR) contains a bit that enables software to clear status bits while the MCU is in a break state.

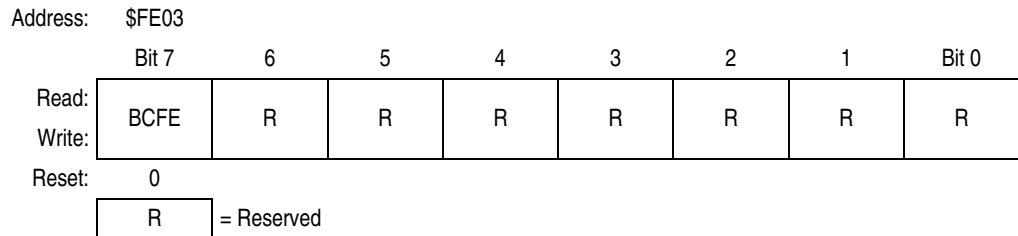

Figure 18-7. SIM Break Flag Control Register (SBFCR)

BCFE — Break Clear Flag Enable Bit

This read/write bit enables software to clear status bits by accessing status registers while the MCU is in a break state. To clear status bits during the break state, the BCFE bit must be set.

- 1 = Status bits clearable during break
- 0 = Status bits not clearable during break

18.3 Monitor ROM (MON)

The monitor ROM (MON) allows complete testing of the microcontroller unit (MCU) through a single-wire interface with a host computer. Monitor mode entry can be achieved without the use of V_{TST} as long as vector addresses \$FFFE and \$FFFF are blank, thus reducing the hardware requirements for in-circuit programming.

Features include:

- Normal user-mode pin functionality
- One pin dedicated to serial communication between monitor ROM and host computer
- Standard mark/space non-return-to-zero (NRZ) communication with host computer
- 4800 baud–28.8 Kbaud communication with host computer
- Execution of code in random-access memory (RAM) or ROM
- FLASH programming

18.3.1 Functional Description

The monitor ROM receives and executes commands from a host computer.

Figure 18-8 shows a sample circuit used to enter monitor mode and communicate with a host computer via a standard RS-232 interface.

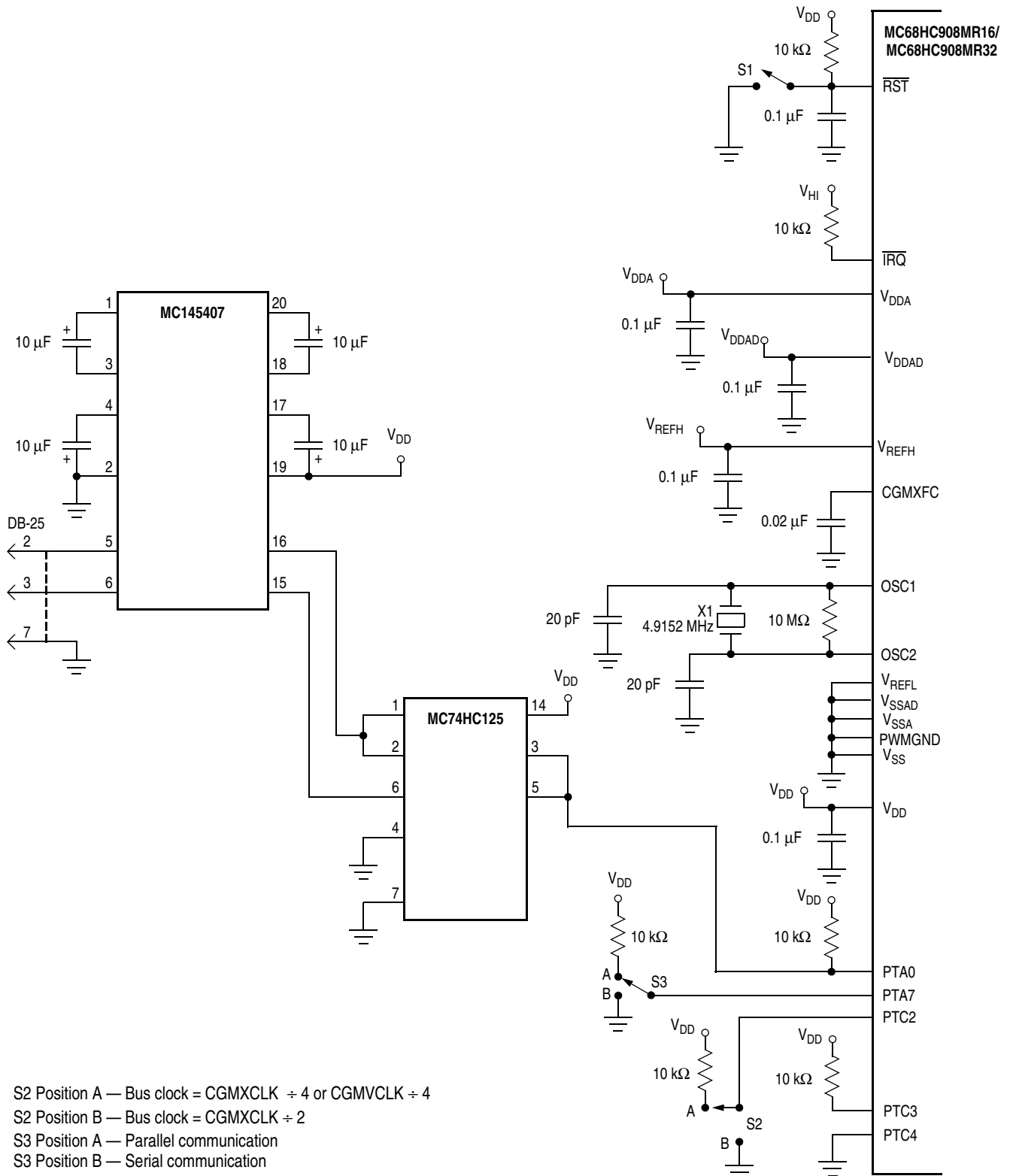

Figure 18-8. Monitor Mode Circuit

Simple monitor commands can access any memory address. In monitor mode, the MCU can execute host-computer code in RAM while all MCU pins retain normal operating mode functions. All communication between the host computer and the MCU is through the PTA0 pin. A level-shifting and multiplexing interface is required between PTA0 and the host computer. PTA0 is used in a wired-OR configuration and requires a pullup resistor.

18.3.1.1 Entering Monitor Mode

There are two methods for entering monitor:

- The first is the traditional M68HC08 method where $V_{DD} + V_{HI}$ is applied to $\overline{IRQ1}$ and the mode pins are configured appropriately.
- A second method, intended for in-circuit programming applications, will force entry into monitor mode without requiring high voltage on the $\overline{IRQ1}$ pin when the reset vector locations of the FLASH are erased (\$FF).

NOTE: For both methods, holding the PTC2 pin low when entering monitor mode causes a bypass of a divide-by-two stage at the oscillator. The CGMOUT frequency is equal to the CGMXCLK frequency, and the OSC1 input directly generates internal bus clocks. In this case, the OSC1 signal must have a 50 percent duty cycle at maximum bus frequency.

Table 18-1 is a summary of the differences between user mode and monitor mode.

Table 18-1. Mode Differences

Modes	Functions						SWI Vector High	SWI Vector Low
	COP	Rest Vector High	Reset Vector Low	Break Vector High	Break Vector Low	SWI Vector High		
User	Enabled	\$FFFE	\$FFFF	\$FFFC	\$FFFD	\$FFFC	\$FFFD	
Monitor	Disabled ⁽¹⁾	\$FEFE	\$FEFF	\$FEFC	\$FEFD	\$FEFC	\$FEFD	

1. If the high voltage ($V_{DD} + V_{HI}$) is removed from the $\overline{IRQ1}$ pin or the \overline{RST} pin, the SIM asserts its COP enable output. The COP is a mask option enabled or disabled by the COPD bit in the configuration register.

18.3.1.2 Normal Monitor Mode

Table 18-2 shows the pin conditions for entering monitor mode.

Table 18-2. Monitor Mode Signal Requirements and Options

IRQ	RESET (S1)	\$/FFFF /\$FFFF	PLL	PTC3	PTC4	PTC2 (S2)	External Clock ⁽¹⁾	CGMOUT	Bus Frequency	COP	For Serial Communication ⁽²⁾			Comment
											PTA0	PTA7 (S3)	Baud Rate ^{(3) (4)}	
X	GND	X	X	X	X	X	X	0	0	Disabled	X	X	0	No operation until reset goes high
V _{TST}	V _{DD} or V _{TST}	X	OFF	1	0	0	4.9152 MHz	4.9152 MHz	2.4576 MHz	Disabled	X	0	9600	PTC3 and PTC2 voltages only required if $\overline{\text{IRQ}} = V_{\text{TST}}$; PTC2 determines frequency divider
V _{TST}	V _{DD} or V _{TST}	X	OFF	1	0	1	9.8304 MHz	4.9152 MHz	2.4576 MHz	Disabled	X	0	9600	PTC3 and PTC2 voltages only required if $\overline{\text{IRQ}} = V_{\text{TST}}$; PTC2 determines frequency divider
V _{DD}	V _{DD}	\$/FFFF Blank	OFF	X	X	X	9.8304 MHz	4.9152 MHz	2.4576 MHz	Disabled	X	0	9600	External frequency always divided by 4
V _{DD} or GND	V _{TST}	\$/FFFF Blank	OFF	X	X	X	X	—	—	Enabled	X	X	—	Enters user mode — will encounter an illegal address reset
V _{DD} or GND	V _{DD} or V _{TST}	Non-\$/FF Programmed	OFF	X	X	X	X	—	—	Enabled	X	X	—	Enters user mode

1. External clock is derived by a 32.768 kHz crystal or a 4.9152/9.8304 MHz off-chip oscillator.

2. DNA = does not apply, X = don't care

3. PTA0 = 1 if serial communication; PTA0 = X if parallel communication

4. PTA7 = 0 → serial, PTA7 = 1 → parallel communication for security code entry

Enter monitor mode by either:

- Executing a software interrupt instruction (SWI) or
- Applying a logic 0 and then a logic 1 to the $\overline{\text{RST}}$ pin

Once out of reset, the MCU waits for the host to send eight security bytes. After receiving the security bytes, the MCU sends a break signal (10 consecutive logic 0s) to the host computer, indicating that it is ready to receive a command. The break signal also provides a timing reference to allow the host to determine the necessary baud rate.

Monitor mode uses alternate vectors for reset and SWI. The alternate vectors are in the \$FE page instead of the \$FF page and allow code execution from the internal monitor firmware instead of user code. The computer operating properly (COP) module is disabled in monitor mode as long as V_{HI} is applied to either the $\overline{\text{IRQ}}$ pin or the $\overline{\text{RST}}$ pin. (See [Section 14. System Integration Module \(SIM\)](#) for more information on modes of operation.)

18.3.1.3 Forced Monitor Mode

If the voltage applied to the $\overline{\text{IRQ1}}$ is less than $V_{\text{DD}} + V_{\text{HI}}$ the MCU will come out of reset in user mode. The MENRST module is monitoring the reset vector fetches and will assert an internal reset if it detects that the reset vectors are erased (\$FF). When the MCU comes out of reset, it is forced into monitor mode without requiring high voltage on the $\overline{\text{IRQ1}}$ pin.

The COP module is disabled in forced monitor mode. Any reset other than a POR reset will automatically force the MCU to come back to the forced monitor mode.

18.3.1.4 Data Format

Communication with the monitor ROM is in standard non-return-to-zero (NRZ) mark/space data format. (See [Figure 18-9](#) and [Figure 18-10](#).)

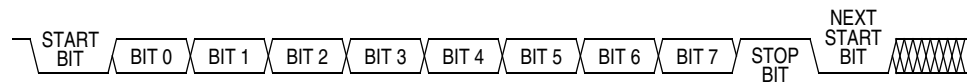

Figure 18-9. Monitor Data Format

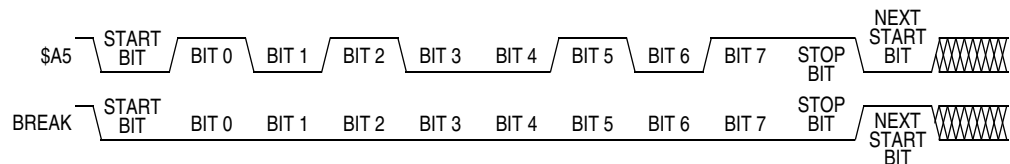

Figure 18-10. Sample Monitor Waveforms

The data transmit and receive rate can be anywhere from 4800 baud to 28.8 Kbaud. Transmit and receive baud rates must be identical.

18.3.1.5 Echoing

As shown in **Figure 18-11**, the monitor ROM immediately echoes each received byte back to the PTA0 pin for error checking.

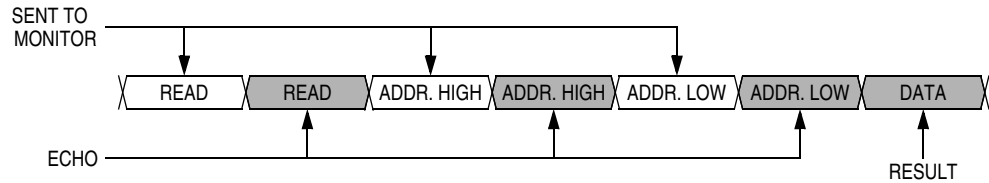

Figure 18-11. Read Transaction

Any result of a command appears after the echo of the last byte of the command.

18.3.1.6 Break Signal

A start bit followed by nine low bits is a break signal. See **Figure 18-12**. When the monitor receives a break signal, it drives the PTA0 pin high for the duration of two bits before echoing the break signal.

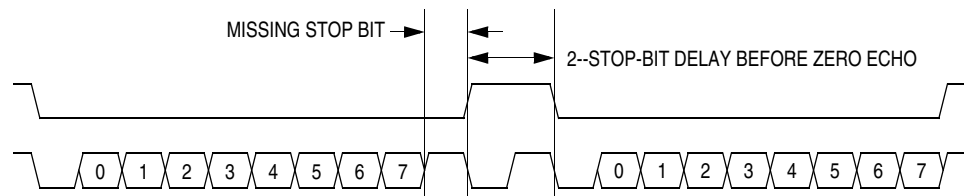

Figure 18-12. Break Transaction

18.3.1.7 Commands

The monitor ROM uses these commands (see **Table 18-3–Table 18-8**):

- READ, read memory
- WRITE, write memory
- IREAD, indexed read
- IWRITE, indexed write
- READSP, read stack pointer
- RUN, run user program

Table 18-3. READ (Read Memory) Command

Description	Read byte from memory
Operand	2-byte address in high-byte:low-byte order
Data Returned	Returns contents of specified address
Opcode	\$4A
Command Sequence	

Table 18-4. WRITE (Write Memory) Command

Description	Write byte to memory
Operand	2-byte address in high-byte:low-byte order; low byte followed by data byte
Data Returned	None
Opcode	\$49
Command Sequence	

Table 18-5. IREAD (Indexed Read) Command

Description	Read next 2 bytes in memory from last address accessed
Operand	2-byte address in high byte:low byte order
Data Returned	Returns contents of next two addresses
Opcode	\$1A
Command Sequence	

Table 18-6. IWRITE (Indexed Write) Command

Description	Write to last address accessed + 1
Operand	Single data byte
Data Returned	None
Opcode	\$19
Command Sequence	

A sequence of IREAD or IWRITE commands can access a block of memory sequentially over the full 64-Kbyte memory map.

Table 18-7. READSP (Read Stack Pointer) Command

Description	Reads stack pointer
Operand	None
Data Returned	Returns incremented stack pointer value (SP + 1) in high-byte:low-byte order
Opcode	\$0C
Command Sequence	

Table 18-8. RUN (Run User Program) Command

Description	Executes PULH and RTI instructions
Operand	None
Data Returned	None
Opcode	\$28
Command Sequence	

18.3.1.8 Baud Rate

With a 4.9152-MHz crystal and the PTC2 pin at logic 1 during reset, data is transferred between the monitor and host at 4800 baud. If the PTC2 pin is at logic 0 during reset, the monitor baud rate is 9600. See [Table 18-9](#).

Table 18-9. Monitor Baud Rate Selection

	VCO Frequency Multiplier (N)					
	1	2	3	4	5	6
Monitor baud rate	4800	9600	14,400	19,200	24,000	28,800

18.3.2 Security

A security feature discourages unauthorized reading of FLASH locations while in monitor mode. The host can bypass the security feature at monitor mode entry by sending eight security bytes that match the bytes at locations \$FFF6–\$FFFD. Locations \$FFF6–\$FFFD contain user-defined data.

NOTE: *Do not leave locations \$FFF6–\$FFFD blank. For security reasons, program locations \$FFF6–\$FFFD even if they are not used for vectors.*

During monitor mode entry, the MCU waits after the power-on reset for the host to send the eight security bytes on pin PTA0. If the received bytes match those at locations \$FFF6–\$FFFD, the host bypasses the security feature and can read all FLASH locations and execute code from FLASH. Security remains bypassed until a power-on reset occurs. If the reset was not a power-on reset, security remains bypassed and security code entry is not required. (See [Figure 18-13](#).)

Upon power-on reset, if the received bytes of the security code do not match the data at locations \$FFF6–\$FFFD, the host fails to bypass the security feature. The MCU remains in monitor mode, but reading a FLASH location returns an invalid value and trying to execute code from FLASH causes an illegal address reset. After receiving the eight security bytes from the host, the MCU transmits a break character, signifying that it is ready to receive a command.

NOTE: *The MCU does not transmit a break character until after the host sends the eight security bytes.*

To determine whether the security code entered is correct, check to see if bit 6 of RAM address \$60 is set. If it is, then the correct security code has been entered and FLASH can be accessed.

If the security sequence fails, the device can be reset (via power-pin reset only) and brought up in monitor mode to attempt another entry. After failing the security sequence, the FLASH mode can also be bulk erased by executing an erase routine that was downloaded into internal RAM. The bulk erase operation clears the security code locations so that all eight security bytes become \$FF.

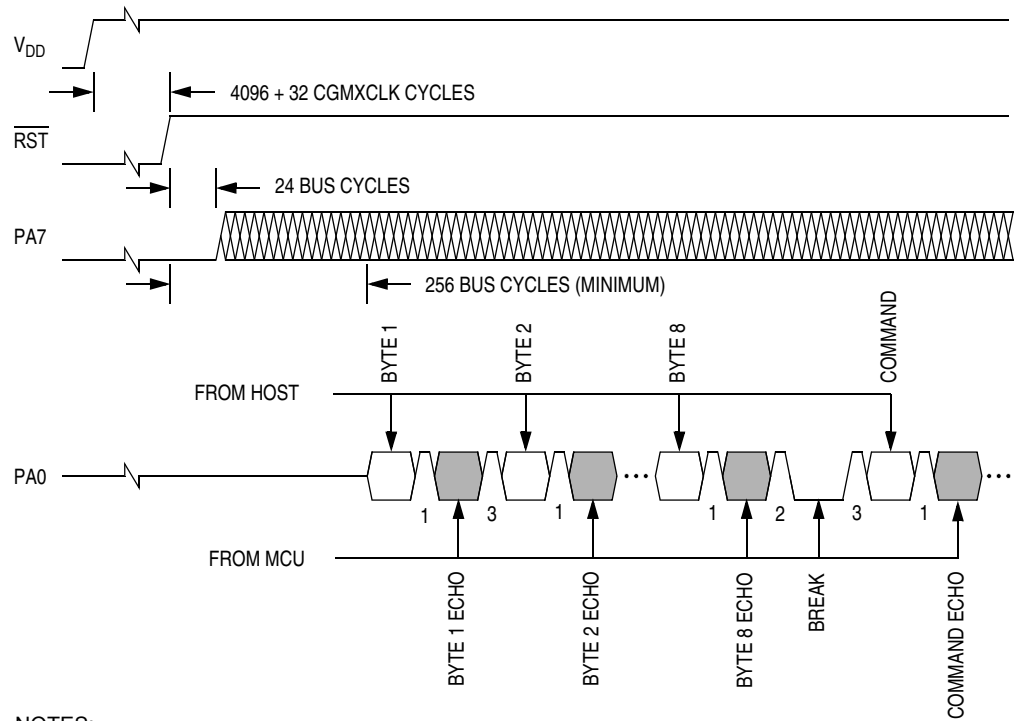

- NOTES:
 1 = Echo delay, 2 bit times
 2 = Data return delay, 2 bit times
 3 = Wait 1 bit time before sending next byte.

Figure 18-13. Monitor Mode Entry Timing

Section 19. Electrical Specifications

19.1 Introduction

This section contains electrical and timing specifications.

19.2 Absolute Maximum Ratings

Maximum ratings are the extreme limits to which the MCU can be exposed without permanently damaging it.

NOTE: *This device is not guaranteed to operate properly at the maximum ratings. For guaranteed operating conditions, refer to [19.5 DC Electrical Characteristics](#).*

Characteristic ⁽¹⁾	Symbol	Value	Unit
Supply voltage	V_{DD}	-0.3 to +6.0	V
Input voltage	V_{In}	$V_{SS} - 0.3$ to $V_{DD} + 0.3$	V
Input high voltage	V_{HI}	$V_{DD} + 4$ maximum	V
Maximum current per pin excluding V_{DD} and V_{SS}	I	±25	mA
Storage temperature	T_{STG}	-55 to +150	°C
Maximum current out of V_{SS}	I_{MVSS}	100	mA
Maximum current into V_{DD}	I_{MVDD}	100	mA

1. Voltages referenced to V_{SS} .

NOTE: *This device contains circuitry to protect the inputs against damage due to high static voltages or electric fields; however, it is advised that normal precautions be taken to avoid application of any voltage higher than maximum-rated voltages to this high-impedance circuit. For proper operation, it is recommended that V_{In} and V_{Out} be constrained to the range $V_{SS} \leq (V_{In} \text{ or } V_{Out}) \leq V_{DD}$. Reliability of operation is enhanced if unused inputs are connected to an appropriate logic voltage level (for example, either V_{SS} or V_{DD}).*

19.3 Functional Operating Range

Characteristic	Symbol	Value	Unit
Operating temperature range ⁽¹⁾ MC68HC908MR24CFU MC68HC908MR24VFU	T _A	–40 to 85 –40 to 105	°C
Operating voltage range	V _{DD}	5.0 ± 10%	V

- See Motorola representative for temperature availability.
C = Extended temperature range (–40°C to +85°C)
V = Automotive temperature range (–40°C to +105°C)

19.4 Thermal Characteristics

Characteristic	Symbol	Value	Unit
Thermal resistance, 64-pin QFP	θ _{JA}	76	°C/W
I/O pin power dissipation	P _{I/O}	User determined	W
Power dissipation ⁽¹⁾	P _D	$P_D = (I_{DD} \times V_{DD}) + P_{I/O} =$ $K/(T_J + 273^\circ\text{C})$	W
Constant ⁽²⁾	K	$P_D \times (T_A + 273^\circ\text{C})$ $+ P_D^2 \times \theta_{JA}$	W/°C
Average junction temperature	T _J	T _A + (P _D × θ _{JA})	°C
Maximum junction temperature	T _{JM}	125	°C

- Power dissipation is a function of temperature.
- K is a constant unique to the device. K can be determined for a known T_A and measured P_D.
With this value of K, P_D and T_J can be determined for any value of T_A.

19.5 DC Electrical Characteristics

Characteristic ⁽¹⁾	Symbol	Min	Typ ⁽²⁾	Max	Unit
Output high voltage ($I_{Load} = -2.0$ mA) all I/O pins	V_{OH}	$V_{DD} - 0.8$	—	—	V
Output low voltage ($I_{Load} = 1.6$ mA) all I/O pins	V_{OL}	—	—	0.4	V
PWM pin output source current ($V_{OH} = V_{DD} - 0.8$ V)	I_{OH}	-7	—	—	mA
PWM pin output sink current ($V_{OL} = 0.8$ V)	I_{OL}	20	—	—	mA
Input high voltage, all ports, \overline{IRQs} , \overline{RESET} , OSC1	V_{IH}	$0.7 \times V_{DD}$	—	V_{DD}	V
Input low voltage, all ports, \overline{IRQs} , \overline{RESET} , OSC1	V_{IL}	V_{SS}	—	$0.3 \times V_{DD}$	V
V_{DD} supply current					
Run ⁽³⁾	I_{DD}	—	—	30	mA
Wait ⁽⁴⁾		—	—	12	mA
Stop ⁽⁵⁾		—	—	700	μ A
I/O ports high-impedance leakage current	I_{IL}	—	—	± 10	μ A
Input current (input only pins)	I_{In}	—	—	± 1	μ A
Capacitance					
Ports (as input or output)	C_{Out} C_{In}	— —	— —	12 8	pF
Low-voltage inhibit reset ⁽⁶⁾	V_{LVR1}	4.0	4.35	4.65	V
Low-voltage reset/recover hysteresis	V_{LVH1}	40	90	150	mV
Low-voltage inhibit reset recovery ($V_{REC1} = V_{LVR1} + V_{LVH1}$)	V_{REC1}	4.04	4.5	4.75	V
Low-voltage inhibit reset	V_{LVR2}	3.85	4.15	4.45	V
Low-voltage reset/recover hysteresis	V_{LVH2}	150	210	250	mV
Low-voltage inhibit reset recovery ($V_{REC2} = V_{LVR2} + V_{LVH2}$)	V_{REC2}	4.0	4.4	4.6	V
POR re-arm voltage ⁽⁷⁾	V_{POR}	0	—	100	mV
POR rise time ramp rate ⁽⁸⁾	R_{POR}	0.035	—	—	V/ms
POR reset voltage ⁽⁹⁾	V_{PORRST}	0	700	800	V
Monitor mode entry voltage (on \overline{IRQ})	V_{Hi}	$V_{DD} + 2.5$	—	8.0	V

- $V_{DD} = 5.0$ Vdc $\pm 10\%$, $V_{SS} = 0$ Vdc, $T_A = T_L$ to T_H , unless otherwise noted.
- Typical values reflect average measurements at midpoint of voltage range, 25°C only.
- Run (operating) I_{DD} measured using external square wave clock source ($f_{OSC} = 8.2$ MHz). All inputs 0.2 V from rail; no dc loads; less than 100 pF on all outputs. $C_L = 20$ pF on OSC2; all ports configured as inputs; OSC2 capacitance linearly affects run I_{DD} ; measured with all modules enabled
- Wait I_{DD} measured using external square wave clock source ($f_{OSC} = 8.2$ MHz); all inputs 0.2 V from rail; no dc loads; less than 100 pF on all outputs. $C_L = 20$ pF on OSC2; all ports configured as inputs; OSC2 capacitance linearly affects wait I_{DD} ; measured with PLL and LVI enabled.
- Stop I_{DD} measured with PLL and LVI disengaged, OCS1 grounded, no port pins sourcing current. It is measured through combination of V_{DD} , V_{DDAD} , and V_{DDA} .
- The low-voltage inhibit reset is software selectable. Refer to [Section 9. Low-Voltage Inhibit \(LVI\)](#).
- Maximum is highest voltage that POR is guaranteed.
- If minimum V_{DD} is not reached before the internal POR is released, \overline{RST} must be driven low externally until minimum V_{DD} is reached.
- Maximum is highest voltage that POR is possible.

19.6 FLASH Memory Characteristics

Characteristic	Symbol	Min	Typ	Max	Unit
RAM data retention voltage	V_{RDR}	1.3	—	—	V
FLASH program bus clock frequency	—	1	—	—	MHz
FLASH read bus clock frequency	$f_{Read}^{(1)}$	0	—	8 M	Hz
FLASH page erase time <1 K cycles >1 K cycles	t_{Erase}	0.9 3.6	1 4	1.1 5.5	ms
FLASH mass erase time	t_{MErase}	4	—	—	ms
FLASH PGM/ERASE to HVEN setup time	t_{NVS}	10	—	—	μ s
FLASH high-voltage hold time	t_{NVH}	5	—	—	μ s
FLASH high-voltage hold time (mass erase)	t_{NVHL}	100	—	—	μ s
FLASH program hold time	t_{PGS}	5	—	—	μ s
FLASH program time	t_{PROG}	30	—	40	μ s
FLASH return to read time	$t_{RCV}^{(2)}$	1	—	—	μ s
FLASH cumulative program HV period	$t_{HV}^{(3)}$	—	—	4	ms
FLASH endurance ⁽⁴⁾	—	10 k	100 k	—	Cycles
FLASH data retention time ⁽⁵⁾	—	15	100	—	Years

- f_{Read} is defined as the frequency range for which the FLASH memory can be read.
- t_{RCV} is defined as the time it needs before the FLASH can be read after turning off the high voltage charge pump, by clearing HVEN to 0.
- t_{HV} is defined as the cumulative high voltage programming time to the same row before next erase.
 t_{HV} must satisfy this condition: $t_{NVS} + t_{NVH} + t_{PGS} + (t_{PROG} \times 32) \leq t_{HV}$ maximum.
- Typical endurance was evaluated for this product family. For additional information on how Motorola defines *Typical Endurance*, please refer to Engineering Bulletin EB619.
- Typical data retention values are based on intrinsic capability of the technology measured at high temperature and de-rated to 25°C using the Arrhenius equation. For additional information on how Motorola defines *Typical Data Retention*, please refer to Engineering Bulletin EB618.

19.7 Control Timing

Characteristic ⁽¹⁾	Symbol	Min	Max	Unit
Frequency of operation ⁽²⁾ Crystal option External clock option ⁽³⁾	f _{OSC}	1 dc ⁽⁴⁾	8 32.8	MHz
Internal operating frequency	f _{OP}	—	8.2	MHz
$\overline{\text{RESET}}$ input pulse width low ⁽⁵⁾	t _{IRL}	50	—	ns

1. V_{DD} = 5.0 Vdc ± 10%, V_{SS} = 0 Vdc; timing shown with respect to 20% V_{DD} and 70% V_{DD}, unless otherwise noted
2. See [19.8 Serial Peripheral Interface Characteristics](#) for more information.
3. No more than 10% duty cycle deviation from 50%.
4. Some modules may require a minimum frequency greater than dc for proper operation; see appropriate table for this information.
5. Minimum pulse width reset is guaranteed to be recognized. It is possible for a smaller pulse width to cause a reset.

19.8 Serial Peripheral Interface Characteristics

Diagram Number ⁽¹⁾	Characteristic ⁽²⁾	Symbol	Min	Max	Unit
	Operating frequency Master Slave	$f_{OP(M)}$ $f_{OP(S)}$	$f_{OP}/128$ dc	$f_{OP}/2$ f_{OP}	MHz
1	Cycle time Master Slave	$t_{CYC(M)}$ $t_{CYC(S)}$	2 1	128 —	t_{CYC}
2	Enable lead time	$t_{Lead(S)}$	15	—	ns
3	Enable lag time	$t_{Lag(S)}$	15	—	ns
4	Clock (SPCK) high time Master Slave	$t_{SCKH(M)}$ $t_{SCKH(S)}$	100 50	— —	ns
5	Clock (SPCK) low time Master Slave	$t_{SCKL(M)}$ $t_{SCKL(S)}$	100 50	— —	ns
6	Data setup time (inputs) Master Slave	$t_{SU(M)}$ $t_{SU(S)}$	45 5	— —	ns
7	Data hold time (inputs) Master Slave	$t_{H(M)}$ $t_{H(S)}$	0 15	— —	ns
8	Access time, slave ⁽³⁾ CPHA = 0 CHPA = 1	$t_{A(CP0)}$ $t_{A(CP1)}$	0 0	40 20	ns
9	Disable time, slave ⁽⁴⁾	$t_{DIS(S)}$	—	25	ns
10	Data valid time after enable edge Master Slave ⁽⁵⁾	$t_{V(M)}$ $t_{V(S)}$	— —	10 40	ns

- $V_{DD} = 5.0 \text{ Vdc} \pm 10\%$, all timing is shown with respect to 20% V_{DD} and 70% V_{DD} , unless otherwise noted; assumes 100 pF load on all SPI pins
- Numbers refer to dimensions in [Figure 19-1](#) and [Figure 19-2](#).
- Time to data active from high-impedance state
- Hold time to high-impedance state
- With 100 pF on all SPI pins

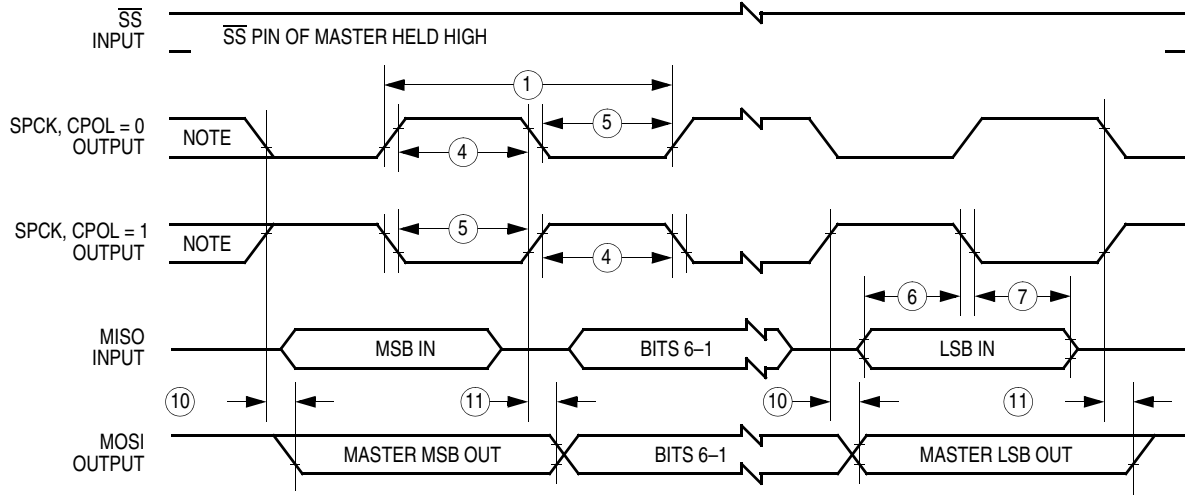

Note: This first clock edge is generated internally, but is not seen at the SCK pin.

a) SPI Master Timing (CPHA = 0)

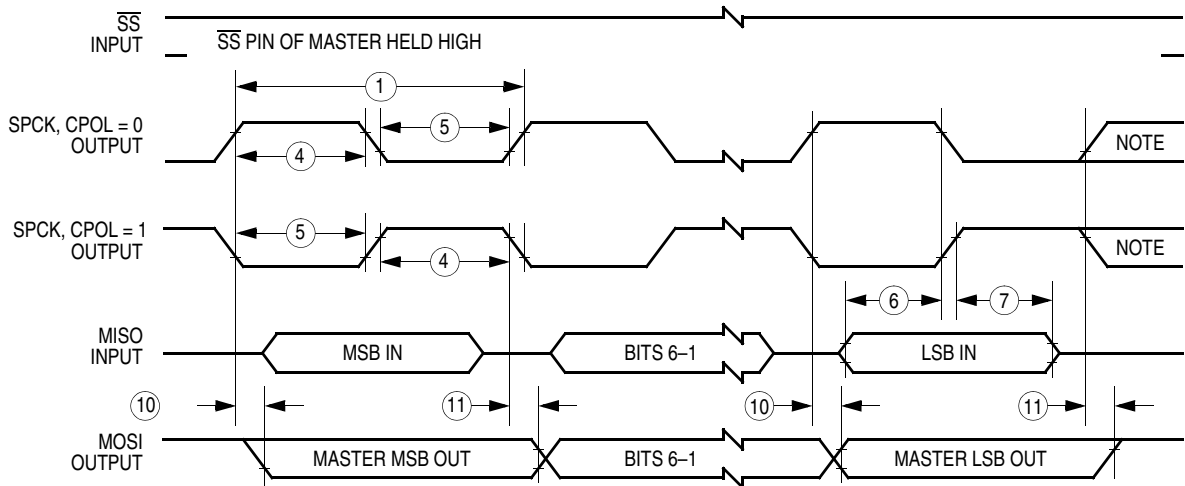

Note: This last clock edge is generated internally, but is not seen at the SCK pin.

b) SPI Master Timing (CPHA = 1)

Figure 19-1. SPI Master Timing

Electrical Specifications

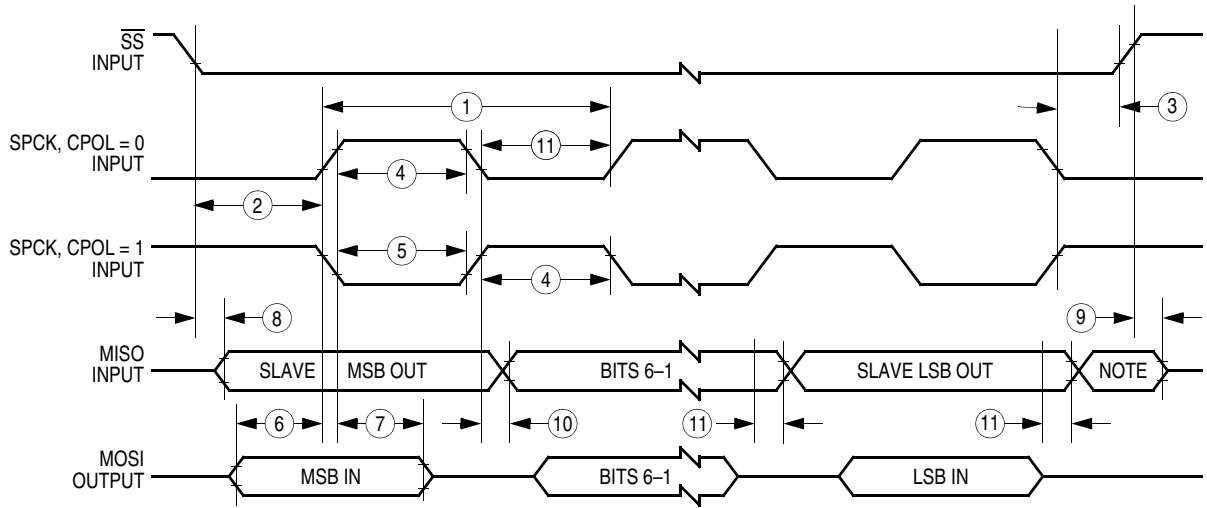

Note: Not defined, but normally MSB of character just received

a) SPI Slave Timing (CPHA = 0)

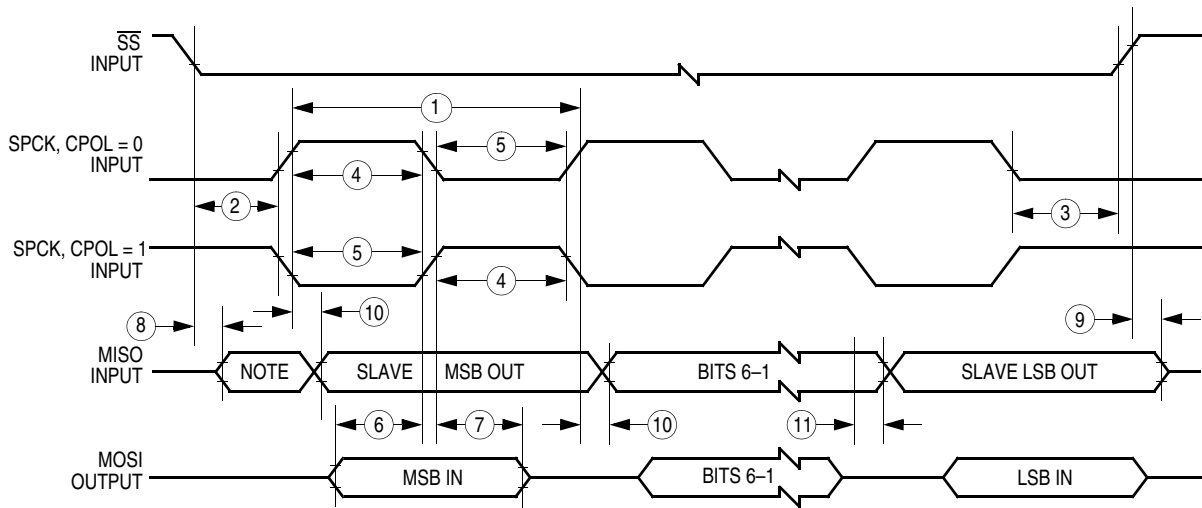

Note: Not defined, but normally LSB of character previously transmitted

b) SPI Slave Timing (CPHA = 1)

Figure 19-2. SPI Slave Timing

19.9 Timer Interface Module Characteristics

Characteristic	Symbol	Min	Max	Unit
Input capture pulse width	t_{TIH}, t_{TIL}	125	—	ns
Input clock pulse width	t_{TCH}, t_{TCL}	$(1/f_{OP}) + 5$	—	ns

19.10 Clock Generation Module Component Specifications

Characteristic	Symbol	Min	Typ	Max	Notes
Crystal load capacitance	C_L	—	—	—	Consult crystal manufacturing data
Crystal fixed capacitance	C_1	—	$2 * C_L$	—	Consult crystal manufacturing data
Crystal tuning capacitance	C_2	—	$2 * C_L$	—	Consult crystal manufacturing data
Feedback bias resistor	R_B	—	22 M Ω	—	
Series resistor	R_S	0	330 k Ω	1 M Ω	Not required
Filter capacitor	C_F	—	C_{FACT}^* (V_{DDA}/f_{XCLK})	—	
Bypass capacitor	C_{BYP}	—	0.1 μ F	—	C_{BYP} must provide low ac impedance from $f = f_{XCLK}/100$ to $100 * f_{VCLK}$, so series resistance must be considered

19.11 CGM Operating Conditions

Characteristic	Symbol	Min	Typ	Max	Unit
Crystal reference frequency	f_{XCLK}	1	—	8	MHz
Range nominal multiplier	f_{NOM}	—	4.9152	—	MHz
VCO center-of-range frequency	f_{VRS}	4.9152	—	32.8	MHz
VCO frequency multiplier	N	1	—	15	—
VCO center of range multiplier	L	1	—	15	—
VCO operating frequency	f_{VCLK}	f_{VRSMIN}	—	f_{VRSMAX}	—

19.12 CGM Acquisition/Lock Time Specifications

Description	Symbol	Min	Typ	Max	Notes
Filter capacitor multiply factor	C_{FACT}	—	0.0154	—	F/sV
Acquisition mode time factor	K_{ACQ}	—	0.1135	—	V
Tracking mode time factor	K_{TRK}	—	0.0174	—	V
Manual mode time to stable	t_{ACQ}	—	$(8 \cdot V_{DDA}) / (f_{XCLK} \cdot K_{ACQ})$	—	If C_F chosen correctly
Manual stable to lock time	t_{AL}	—	$(4 \cdot V_{DDA}) / (f_{XCLK} \cdot K_{TRK})$	—	If C_F chosen correctly
Manual acquisition time	t_{Lock}	—	$t_{ACQ} + t_{AL}$	—	
Tracking mode entry frequency tolerance	Δ_{TRK}	0	—	$\pm 3.6\%$	
Acquisition mode entry frequency tolerance	Δ_{ACQ}	$\pm 6.3\%$	—	$\pm 7.2\%$	
Lock entry frequency tolerance	Δ_{Lock}	0	—	$\pm 0.9\%$	
Lock exit frequency tolerance	Δ_{UNL}	$\pm 0.9\%$	—	$\pm 1.8\%$	
Reference cycles per acquisition mode measurement	n_{ACQ}	—	32	—	
Reference cycles per tracking mode measurement	n_{TRK}	—	128	—	
Automatic mode time to stable	t_{ACQ}	n_{ACQ} / f_{XCLK}	$(8 \cdot V_{DDA}) / (f_{XCLK} \cdot K_{ACQ})$	—	If C_F chosen correctly
Automatic stable to lock time	t_{AL}	n_{TRK} / f_{XCLK}	$(4 \cdot V_{DDA}) / (f_{XCLK} \cdot K_{TRK})$	—	If C_F chosen correctly
Automatic lock time	t_{Lock}	—	$t_{ACQ} + t_{AL}$	—	
PLL jitter (deviation of average bus frequency over 2 ms)	f_J	0	—	$\pm (f_{XCLK}) \cdot (0.025\%) \cdot (N/4)$	N = VCO freq. mult.

Freescale Semiconductor, Inc.

19.13 Analog-to-Digital Converter (ADC) Characteristics

Characteristic	Symbol	Min	Typ	Max	Unit	Notes
Supply voltage	V_{DDAD}	4.5	—	5.5	V	V_{DDAD} should be tied to the same potential as V_{DD} via separate traces
Input voltages	V_{ADIN}	0	—	V_{DDAD}	V	$V_{ADIN} \leq V_{DDAD}$
Resolution	B_{AD}	10	—	10	Bits	
Absolute accuracy	A_{AD}	—	—	± 4	LSB	Includes quantization
ADC internal clock	f_{ADIC}	500 k	—	1.048 M	Hz	$t_{AIC} = 1/f_{ADIC}$
Conversion range	R_{AD}	V_{SSAD}	—	V_{DDAD}	V	
Power-up time	t_{ADPU}	16	—	—	t_{AIC} cycles	
Conversion time	t_{ADC}	16	—	17	t_{AIC} cycles	
Sample time	t_{ADS}	5	—	—	t_{AIC} cycles	
Monotonicity	M_{AD}	Guaranteed				
Zero input reading	Z_{ADI}	000	—	003	Hex	$V_{ADIN} = V_{SSAD}$
Full-scale reading	F_{ADI}	3FC	—	3FF	Hex	$V_{ADIN} = V_{DDAD}$
Input capacitance	C_{ADI}	—	—	30	pF	Not tested
V_{REFH}/V_{REFL} current	I_{VREF}	—	1.6	—	mA	
Absolute accuracy (8-bit truncation mode)	A_{AD}	—	—	± 1	LSB	Includes quantization
Quantization error (8-bit truncation mode)	—	—	—	$+ 7/8$ $- 1/8$	LSB	

Section 20. Ordering Information and Mechanical Specifications

20.1 Introduction

This section provides ordering information for the MC68HC908MR16 and MC68HC908MR32 along with the dimensions for:

- 64-lead plastic quad flat pack (QFP)
- 56-pin shrink dual in-line package (SDIP)

The following figures show the latest package drawings at the time of this publication. To make sure that you have the latest package specifications, contact your local Motorola Sales Office.

20.2 Order Numbers

Table 20-1. Order Numbers

MC Order Number ⁽¹⁾	Operating Temperature Range
68HC908MR16CFU 68HC908MR16VFU	-40°C to +85°C -40°C to +105°C
68HC908MR16CB 68HC908MR16VB	-40°C to +85°C -40°C to +105°C
68HC908MR32CFU 68HC908MR32VFU	-40°C to +85°C -40°C to +105°C
68HC908MR32CB 68HC908MR32VB	-40°C to +85°C -40°C to +105°C

1. FU = quad flat pack
B = shrink dual in-line package

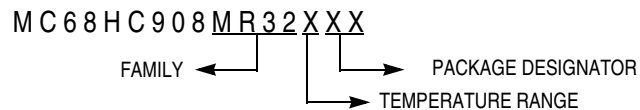
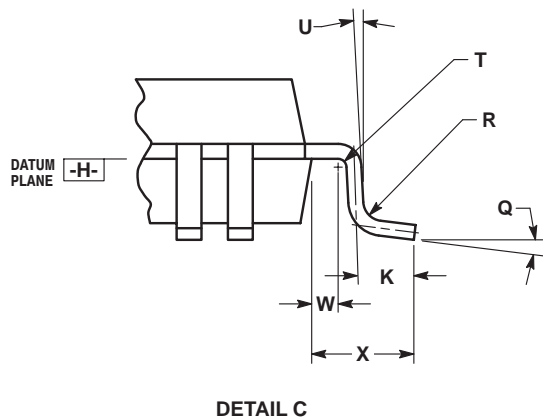
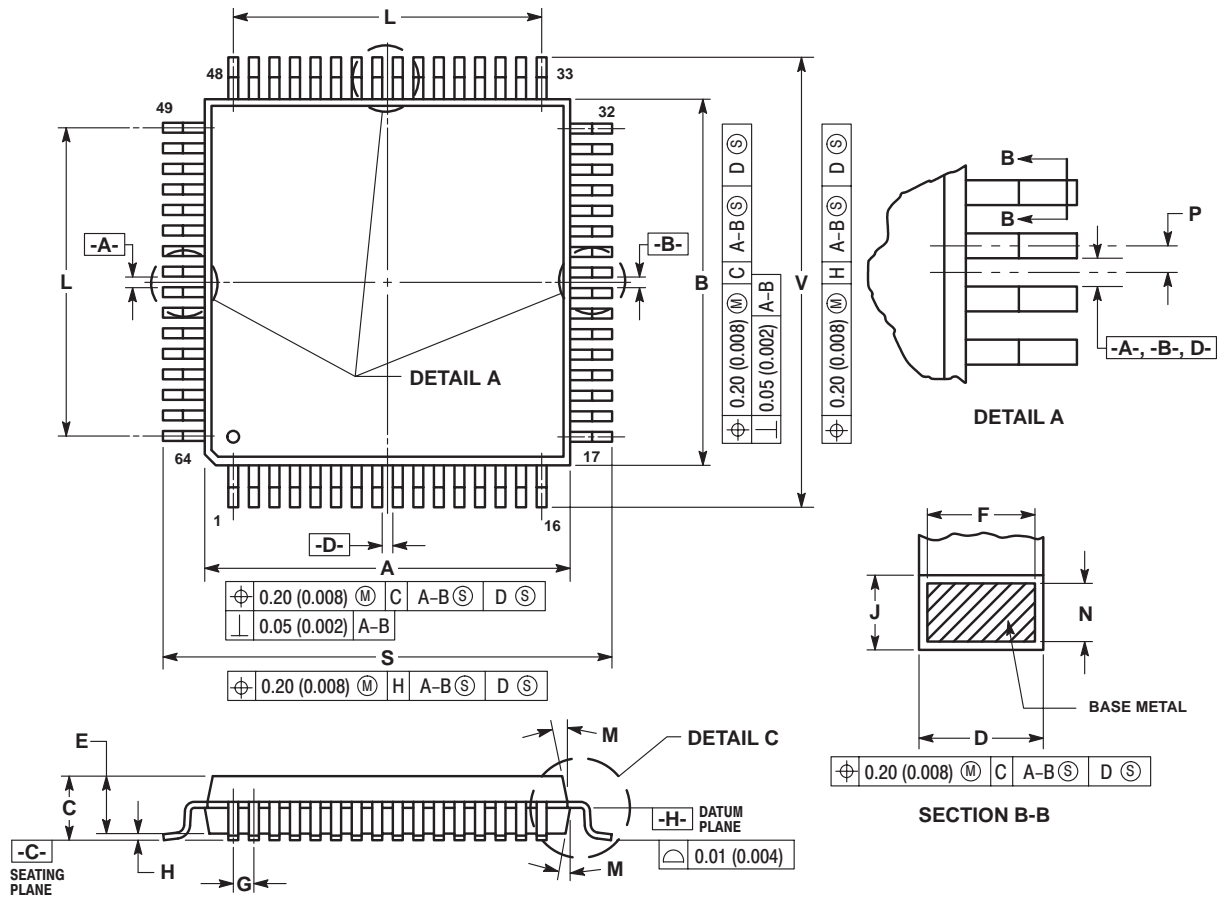

Figure 20-1. Device Numbering System

20.3 64-Pin Plastic Quad Flat Pack (QFP)



- NOTES:
1. DIMENSIONING AND TOLERANCING PER ANSI Y14.5M, 1982.
 2. CONTROLLING DIMENSION: MILLIMETER.
 3. DATUM PLANE -H- IS LOCATED AT BOTTOM OF LEAD AND IS COINCIDENT WITH THE LEAD WHERE THE LEAD EXITS THE PLASTIC BODY AT THE BOTTOM OF THE PARTING LINE.
 4. DATUMS A-B AND -D- TO BE DETERMINED AT DATUM PLANE -H-.
 5. DIMENSIONS S AND V TO BE DETERMINED AT SEATING PLANE -C-.
 6. DIMENSIONS A AND B DO NOT INCLUDE MOLD PROTRUSION. ALLOWABLE PROTRUSION IS 0.25 (0.010) PER SIDE. DIMENSIONS A AND B DO NOT INCLUDE MOLD MISMATCH AND ARE DETERMINED AT DATUM PLANE -H-.
 7. DIMENSION D DOES NOT INCLUDE DAMBAR PROTRUSION. ALLOWABLE DAMBAR PROTRUSION SHALL BE 0.08 (0.003) TOTAL IN EXCESS OF THE D DIMENSION AT MAXIMUM MATERIAL CONDITION. DAMBAR CANNOT BE LOCATED ON THE LOWER RADIUS OR THE FOOT.

DIM	MILLIMETERS		INCHES	
	MIN	MAX	MIN	MAX
A	13.90	14.10	0.547	0.555
B	13.90	14.10	0.547	0.555
C	2.15	2.45	0.085	0.096
D	0.30	0.45	0.012	0.018
E	2.00	2.40	0.079	0.094
F	0.30	0.40	0.012	0.016
G	0.80 BSC		0.031 BSC	
H	— 0.25		— 0.010	
J	0.13	0.23	0.005	0.009
K	0.65	0.95	0.026	0.037
L	12.00 REF		0.472 REF	
M	5°	10°	5°	10°
N	0.13	0.17	0.005	0.007
P	0.40 BSC		0.016 BSC	
Q	0°	7°	0°	7°
R	0.13	0.30	0.005	0.012
S	16.95	17.45	0.667	0.687
T	0.13	—	0.005	—
U	0°	—	0°	—
V	16.95	17.45	0.667	0.687
W	0.35	0.45	0.014	0.018
X	1.6 REF		0.063 REF	

20.4 56-Pin Shrink Dual In-Line Package (SDIP)

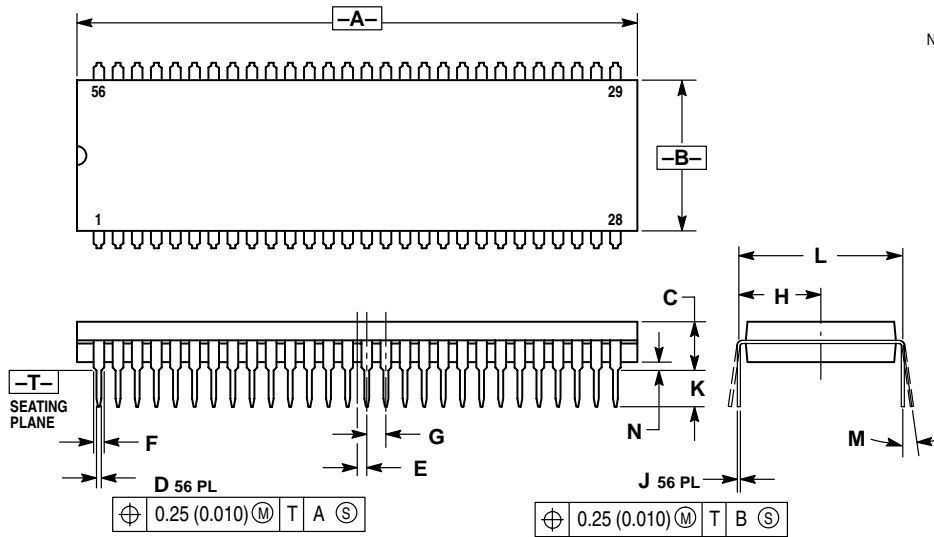

NOTES:

1. DIMENSIONING AND TOLERANCING PER ANSI Y14.5M, 1982.
2. CONTROLLING DIMENSION: INCH.
3. DIMENSION L TO CENTER OF LEAD WHEN FORMED PARALLEL.
4. DIMENSIONS A AND B DO NOT INCLUDE MOLD FLASH. MAXIMUM MOLD FLASH 0.25 (0.010)

DIM	INCHES		MILLIMETERS	
	MIN	MAX	MIN	MAX
A	2.035	2.065	51.69	52.45
B	0.540	0.560	13.72	14.22
C	0.155	0.200	3.94	5.08
D	0.014	0.022	0.36	0.56
E	0.035 BSC		0.89 BSC	
F	0.032	0.046	0.81	1.17
G	0.070 BSC		1.778 BSC	
H	0.300 BSC		7.62 BSC	
J	0.008	0.015	0.20	0.38
K	0.115	0.135	2.92	3.43
L	0.600 BSC		15.24 BSC	
M	0° 15°		0° 15°	
N	0.020	0.040	0.51	1.02

Freescale Semiconductor, Inc.

Appendix A. MC68HC908MR16

The information contained in this document pertains to the MC68HC908MR16 with the exception of that shown in [Figure A-1](#).

\$0000 ↓ \$005F	I/O REGISTERS — 96 BYTES
\$0060 ↓ \$035F	RAM — 768 BYTES
\$0360 ↓ \$7FFF	UNIMPLEMENTED — 31,904 BYTES
\$8000 ↓ \$BEFF	FLASH — 16,128 BYTES
\$BF00 ↓ \$DFFF	UNIMPLEMENTED — 16,128 BYTES
\$FE00	SIM BREAK STATUS REGISTER (SBSR)
\$FE01	SIM RESET STATUS REGISTER (SRSR)
\$FE02	RESERVED
\$FE03	SIM BREAK FLAG CONTROL REGISTER (SBFCR)
\$FE04	RESERVED
\$FE05	RESERVED
\$FE06	RESERVED
\$FE07	RESERVED
\$FE08	FLASH CONTROL REGISTER (FLCR)
\$FE09	UNIMPLEMENTED
\$FE0A	UNIMPLEMENTED
\$FE0B	UNIMPLEMENTED
\$FE0C	SIM BREAK ADDRESS REGISTER HIGH (BRKH)
\$FE0D	SIM BREAK ADDRESS REGISTER LOW (BRKL)
\$FE0E	SIM BREAK FLAG CONTROL REGISTER (SBFCR)
\$FE0F	LVI STATUS AND CONTROL REGISTER (LVISCR)
\$FE10 ↓ \$FEFF	MONITOR ROM — 240 BYTES
\$FF00 ↓ \$FF7D	UNIMPLEMENTED — 126 BYTES
\$FF7E	FLASH BLOCK PROTECT REGISTER (FLBPR)
\$FF7F ↓ \$FFD1	UNIMPLEMENTED — 83 BYTES
\$FFD2 ↓ \$FFFF	VECTORS — 46 BYTES

Figure A-1. MC68HC908MR16 Memory Map

HOW TO REACH US:

USA/EUROPE/LOCATIONS NOT LISTED:

Motorola Literature Distribution
P.O. Box 5405
Denver, Colorado 80217
1-800-521-6274 or 480-768-2130

JAPAN:

Motorola Japan Ltd.
SPS, Technical Information Center
3-20-1, Minami-Azabu, Minato-ku
Tokyo 106-8573, Japan
81-3-3440-3569

ASIA/PACIFIC:

Motorola Semiconductors H.K. Ltd.
Silicon Harbour Centre
2 Dai King Street
Tai Po Industrial Estate
Tai Po, N.T., Hong Kong
852-26668334

HOME PAGE:

<http://motorola.com/semiconductors>



Information in this document is provided solely to enable system and software implementers to use Motorola products. There are no express or implied copyright licenses granted hereunder to design or fabricate any integrated circuits or integrated circuits based on the information in this document.

Motorola reserves the right to make changes without further notice to any products herein. Motorola makes no warranty, representation or guarantee regarding the suitability of its products for any particular purpose, nor does Motorola assume any liability arising out of the application or use of any product or circuit, and specifically disclaims any and all liability, including without limitation consequential or incidental damages. "Typical" parameters that may be provided in Motorola data sheets and/or specifications can and do vary in different applications and actual performance may vary over time. All operating parameters, including "Typicals", must be validated for each customer application by customer's technical experts. Motorola does not convey any license under its patent rights nor the rights of others. Motorola products are not designed, intended, or authorized for use as components in systems intended for surgical implant into the body, or other applications intended to support or sustain life, or for any other application in which the failure of the Motorola product could create a situation where personal injury or death may occur. Should Buyer purchase or use Motorola products for any such unintended or unauthorized application, Buyer shall indemnify and hold Motorola and its officers, employees, subsidiaries, affiliates, and distributors harmless against all claims, costs, damages, and expenses, and reasonable attorney fees arising out of, directly or indirectly, any claim of personal injury or death associated with such unintended or unauthorized use, even if such claim alleges that Motorola was negligent regarding the design or manufacture of the part.

MOTOROLA and the Stylized M Logo are registered in the US Patent and Trademark Office. All other product or service names are the property of their respective owners. Motorola, Inc. is an Equal Opportunity/Affirmative Action Employer.

© Motorola Inc. 2003

MC68HC908MR32/D
Rev. 6.0
11/2003

**For More Information On This Product,
Go to: www.freescale.com**