

### ◆ Description

The S8300 is an integrated adjustable constant-current source, driving loads up to 600mA. The output current level can be adjusted via an external resistor( $R_{FB}$ ). The integrated SHDN input of the S8300P permits LED brightness regulation by pulse width modulation (PWM), with the SHDN input, the LED brightness can be regulated via duty cycle. Also, SHDN low sets the S8300 in sleep mode, the SHDN pin also can be used as an enable input.

This discrete integration technology eliminates individual components by combining them into a single package, which results in a significant reduction of both system cost and board space.

### ◆ Features

- Supplies stable bias current for LEDs
- LED drive current adjustable via single external resistor (Max 600mA)
- Low Cost, Low External Parts Count
- Halogen-Free Package is Available

### ◆ Pin Assignment & Description

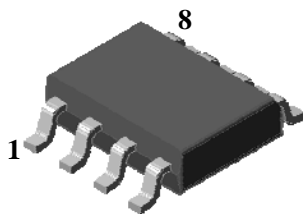

Package : SOP-8

Pin No	Symbol	Description
1	VCC	Power Supply
2	SHDN	Disable On/Off
3	GND	Ground
4	N.C	No connection
5	N.C	No connection
6	N.C	No connection
7	OUTPUT	Open Collector Output
8	FB	Feedback / 0.2V Reference

### ◆ Ordering Information

Package Type	Device Name	Marking
SOP-8	S8300	S8300

## ◆ Absolute maximum ratings

[Ta=25°C]

Characteristic	Symbol	Rating	Unit
Power Supply Voltage	$V_{CC(MAX)}$	25	V
Output Voltage	$V_{OUT(MAX)}$	25	V
Output Sink Current	$I_{OUT(MAX)}$	600	mA
Thermal Resistance Junction-Ambient	$R_{th(j-a)}^*$	156.3	°C/W
Power Dissipation	$P_D^*$	0.8	W
Operating Temperature Range	$T_{opr}$	-40 ~ +85	°C
Storage Temperature Range	$T_{stg}$	-55 ~ +125	°C

\* : Mounted on a glass epoxy circuit board of 50x50mm Pad dimension of 50mm<sup>2</sup>

## ◆ Recommended operating conditions

Characteristic	Symbol	Rating		Unit
		Min	Max	
Power Supply Voltage	$V_{CC}$	3	24	V
Output Voltage	$V_{OUT}$	1.5	V <sub>CC</sub>	V
Output Sink Current	$I_{OUT}$	-	500	mA
Shut Down Voltage	SHDN	-0.3	V <sub>CC</sub>	V

## ◆ Electrical Characteristics (Ta=25°C, unless otherwise noted.)

Characteristic	Symbol	Condition	Min.	Typ.	Max.	Unit
IQ Maximum	$I_Q$	$V_{CC}=3\sim 24V, I_{out}=20mA, V_{out}=open$	-	8	12	mA
Leak Current	$I_{leak}$	$V_{CC}=5V, V_{out}=24V$	-	0.1	1	μA
Feedback Voltage	$V_{FB}$	$V_{CC}=5V, I_{out}=10mA$	-	200	208	mV
Dropout Voltage	$V_{drop}$	$V_{CC}=5V, I_{out}=500mA$	-	0.5	1.5	V
Line Regulation	$\Delta V_{FB1}$	$V_{CC}=3V\sim 24V, I_{out}=10mA$	-	2	10	mV
Load Regulation	$\Delta V_{FB2}$	$V_{CC}=5V, I_{out}=10mA\sim I_{omax}$	-	3	25	mV
SHDN Voltage On	$V_{dis\ on}$	$V_{CC}=5V, I_{out}=10mA, V_{out}=V_{CC}$	1.5	-	-	V
SHDN Voltage Off	$V_{dis\ off}$	$V_{CC}=5V, I_{out}=10mA$	-	-	0.5	V
SHDN Pin Current	$I_{dis}$	$V_{CC}=5V, SHDN=5V$	230	430	630	μA
Short Circuit Current	$I_{SC}$	$R_{FB}=0\Omega$	-	1300	-	mA
Thermal Shutdown	$T_{TSD}$	-	-	160	-	°C

### ◆ Functional block diagram

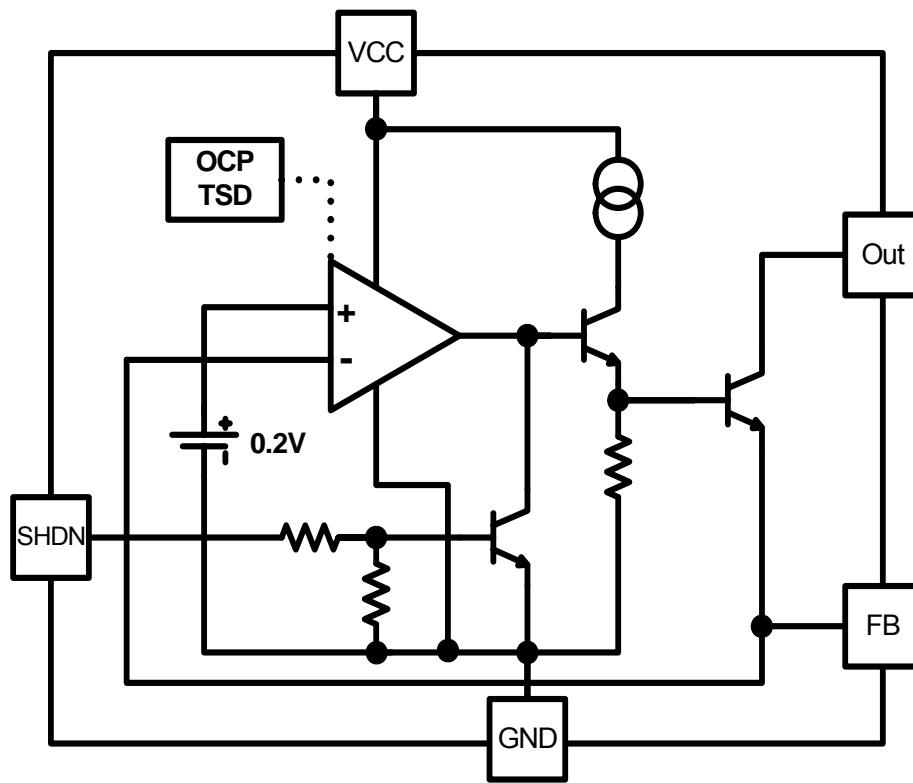

### ◆ Design Consideration

1) Calculation for  $R_{FB}$

$$- R_{FB} = 0.2V / I_{LED}$$

2) Calculation for  $V_{drop}$

$$- V_{drop} = V_{CC} - V_{LED}$$

3) Calculation for Power Dissipation on the S8300P

$$- P_{D1} = (V_{drop} - V_{FB}) \times I_{LED}$$

$$- P_{D2} = V_{CC} \times I_Q$$

$$- P_{D(total)} = P_{D1} + P_{D2}$$

4) If does not use an Dimming function, connect SHDN Pin with the ground.

5) When  $V_{cc}$  uses to exceed 25V, Dimming functions the use is impossible.

◆ Typical Applications

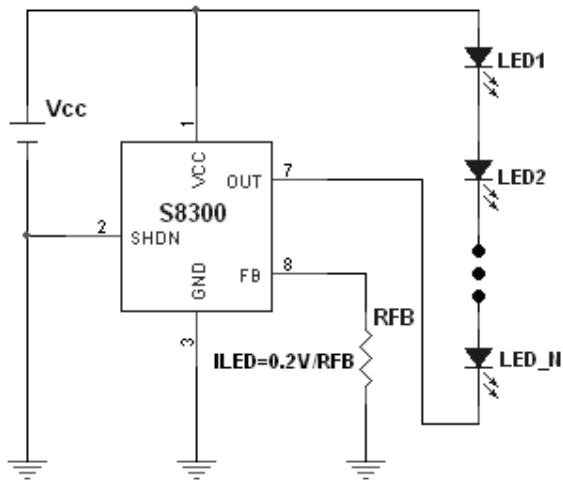

<APP1. Constant Current LED Driver Circuit>

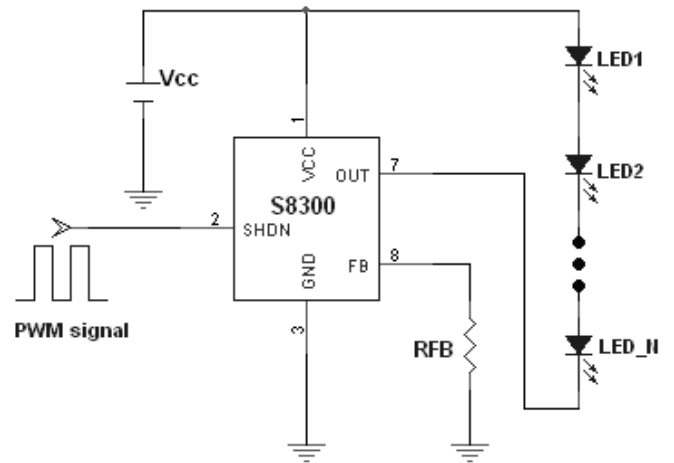

<APP2. PWM Dimming LED Driver Circuit>

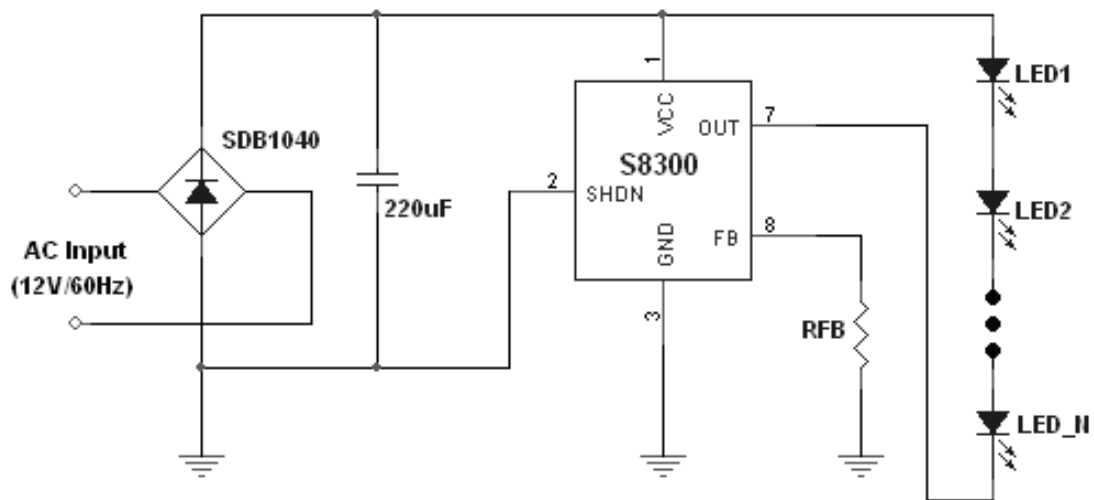

<APP3. V<sub>AC</sub> Landscape Lighting Application Circuit>

◆ Typical Applications

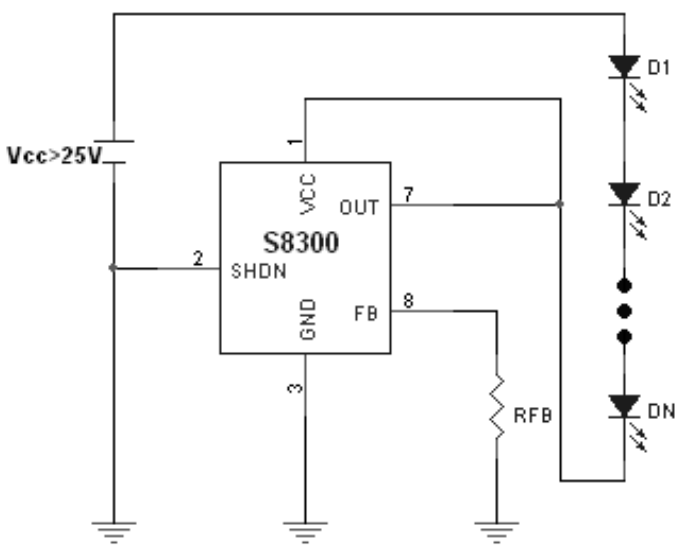

<APP4. High Voltage Operation of S8300P (1) >

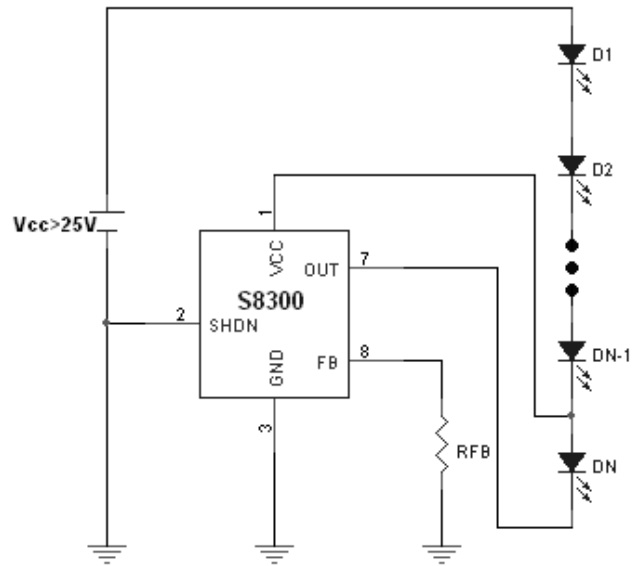

<APP5. High Voltage Operation of S8300P (2) >

For operation in excess of S8300 specified maximum voltage ( $V_{CC}$  &  $V_{OUT}$ ) of 25V, one way is to connect a sufficient number of LEDs between the power supply voltage and the DC input of the  $V_{CC}$  &  $V_{OUT}$  such that the voltage seen at pin( $V_{CC}$  &  $V_{OUT}$ ) is less than 25V.

That is to say, use additional LEDs to drop the voltage fed to the S8300 below its maximum rating, in the usual way. Refer to **APP4,5** Note that the exact number of diodes required will depend on the supply voltage  $V_{CC}$  and output voltage  $V_{OUT}$ , the voltage drops across the particular LEDs being used. (Red, Blue and White LEDs have different forward voltage drop.) Use enough LEDs such that voltage at pin( $V_{CC}$  &  $V_{OUT}$ ) of S8300 is < 25V

※ Caution : When  $V_S$  uses to exceed 25V, Dimming functions the use is impossible.

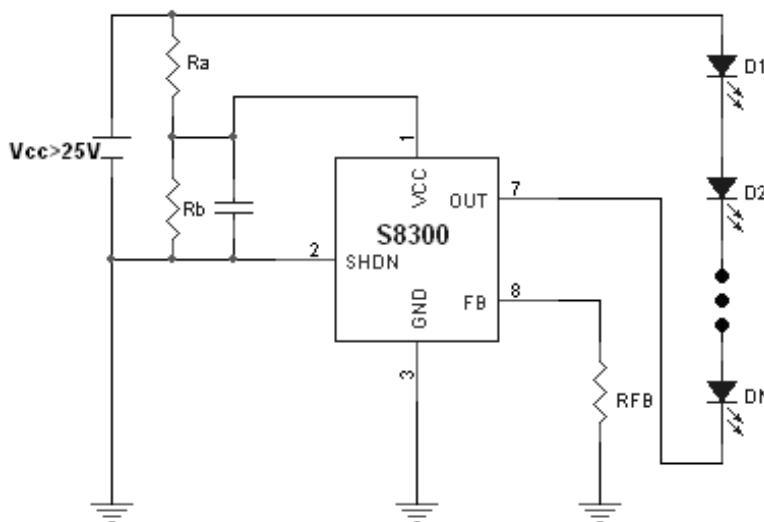

<APP6. Power Supply Where Separates Operation of S8300P >

◆ Electrical Characteristic Curves

Fig.1  $V_{FB}$  vs  $T_A$

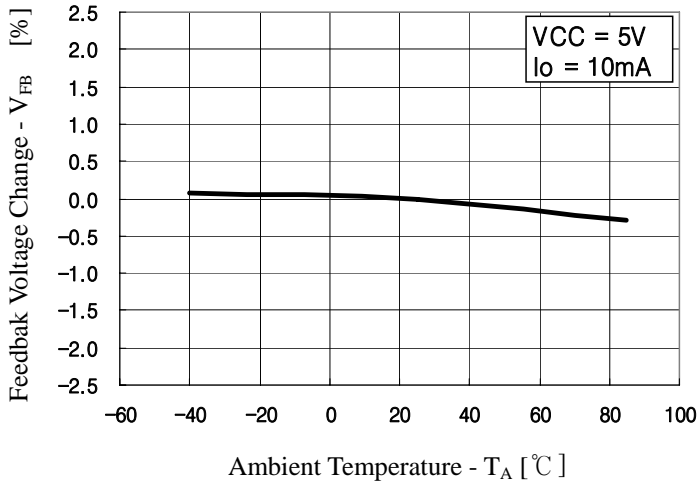

Fig.2 Line Regulation vs  $T_A$

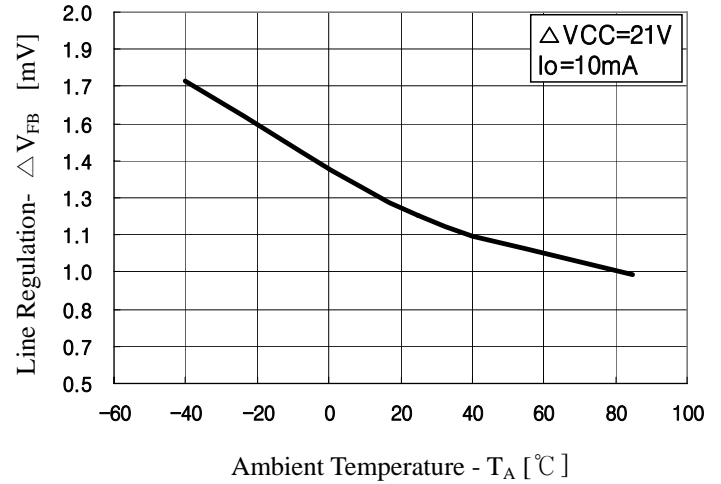

Fig.3 Load Regulation vs  $T_A$

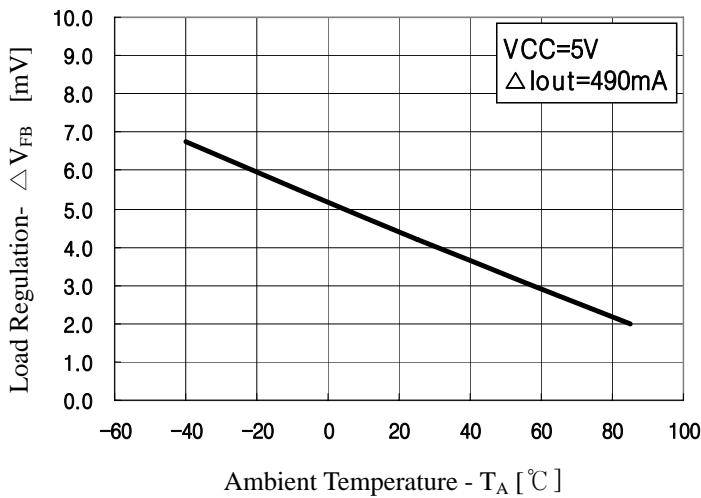

Fig.4 Quiescent Current vs  $T_A$

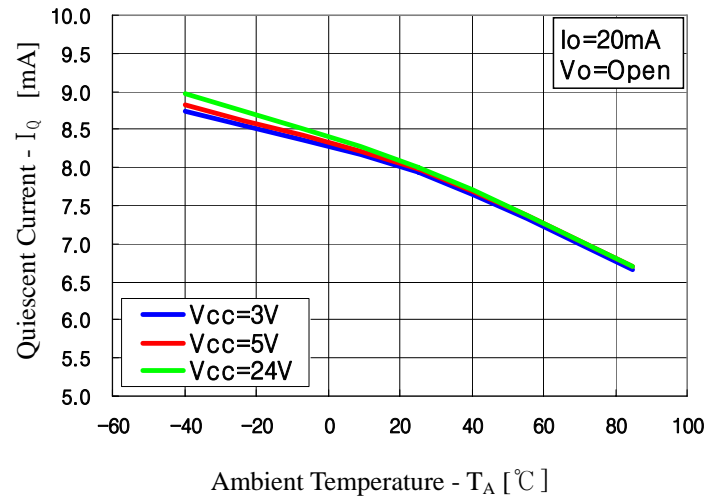

Fig.5 Dropout Voltage vs  $T_A$

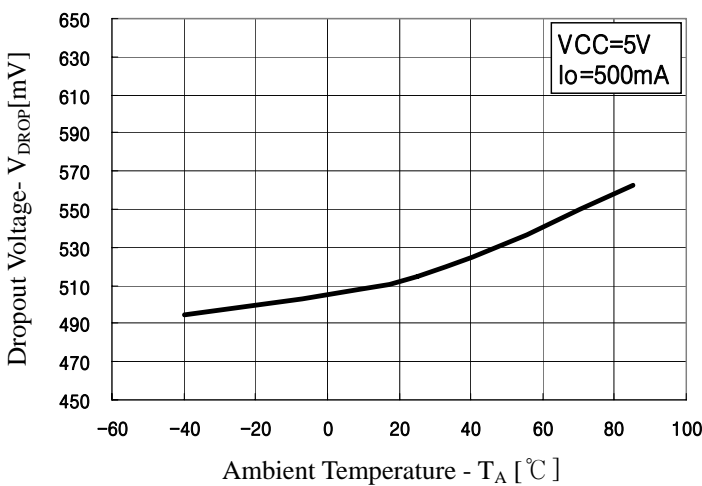
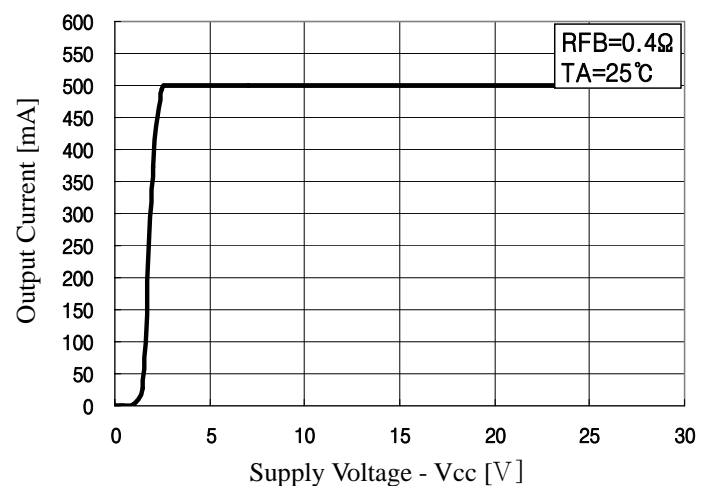

Fig.6 Output Current vs Supply Voltage



◆ Electrical Characteristic Curves

Fig.7 Dimming Curve

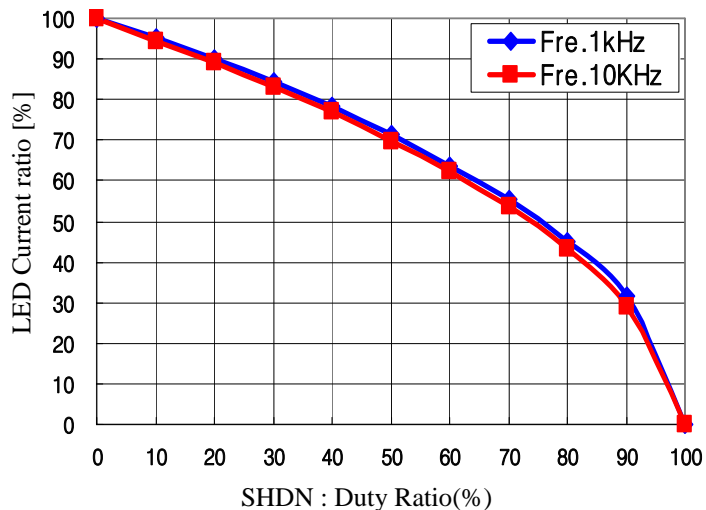

Fig.8 Short Circuit Current

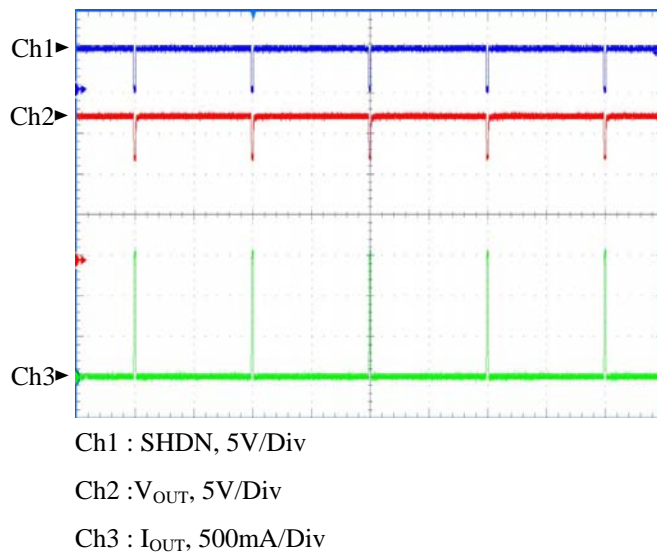
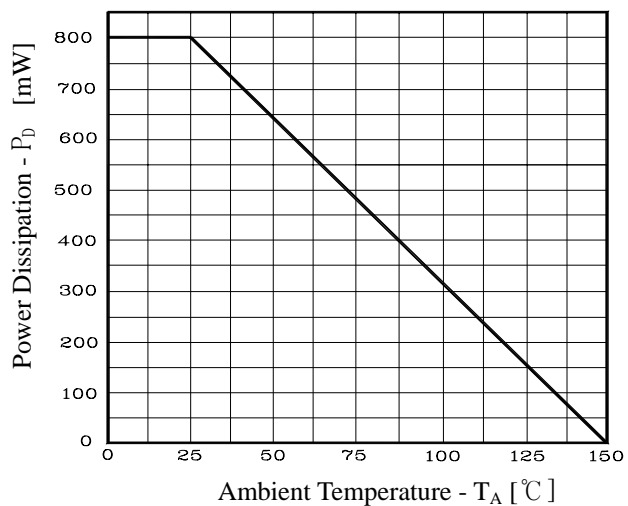
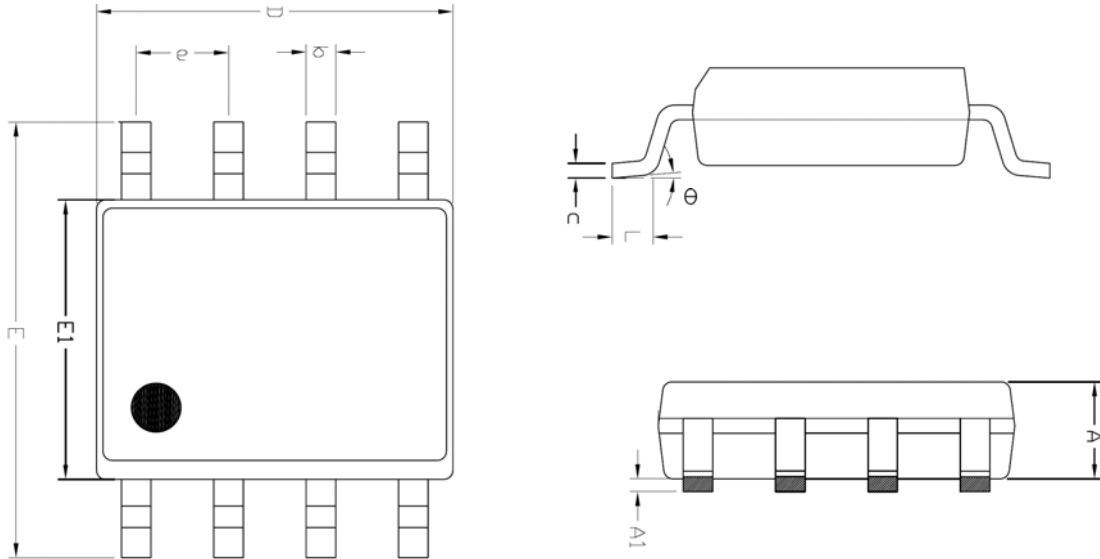

Fig.9 Power Dissipation vs T<sub>A</sub>



SOP-8 Outline Dimension (mm)



SYMBOL	MILLIMETER(mm)			NOTE
	MINIMUM	NOMINAL	MAXIMUM	
A	1.245	—	1.445	
A1	0.125	0.175	0.275	
b	0.320	0.420	0.520	
c	0.170	0.220	0.270	
D	4.802	4.902	5.002	
E	5.870	6.020	6.170	
E1	3.761	3.861	3.961	
e	1.270 BSC			
L	0.462	0.562	0.662	
$\theta$	0°	—	8°	

※ Recommend PCB solder land [Unit: mm]

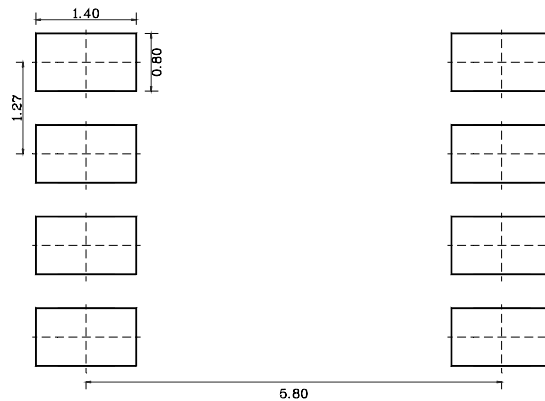



**The AUK Corp. products are intended for the use as components in general electronic equipment (Office and communication equipment, measuring equipment, home appliance, etc.).**

**Please make sure that you consult with us before you use these AUK Corp. products in equipments which require high quality and / or reliability, and in equipments which could have major impact to the welfare of human life(atomic energy control, airplane, spaceship, transportation, combustion control, all types of safety device, etc.). AUK Corp. cannot accept liability to any damage which may occur in case these AUK Corp. products were used in the mentioned equipments without prior consultation with AUK Corp..**

**Specifications mentioned in this publication are subject to change without notice.**