

2-Wire/4-Wire Telephone Line Interface**Description**

The XE0204 provides a common telephone interface for networks integrating two and four-wire telephone connections. The XE0204 supplies two and four wire leased line connections, and complies with FCC Part 68 Rules for 2-wire connections to the public switched network.

The XE0204 supports voice, data and fax transfer at speeds to 14,400 Bits Per Second, V.32bis data transfer over two wires and V.33 data transfer over four wires.

The XE0204 is a complete DAA in a compact package. It includes the telephone line transformers, loop current holding circuit, ring detection, switch hook, two-to-four wire convertor and four-wire switch. The small size of the XE0204, just 1.5 square inches, allows the XE0204 to be used in most any application requiring connection to the telephone network.

Features

- * Small Size 0 1.5" x 1.08" 0.42"
- * FCC Part 68 Compliant
- * Integral Ring Detection
- * Integrated Switch Hook
- * Switchable between two-wire and four-wire lines
- * Integral two-to-four wire convertor
- * Integrated telephone line transformers
- * 1500 volt isolation barrier between the telephone line and host equipment
- * Supports both dial-up and leased line applications
- * Supports 14,400 BPS data transfer; V.32bis (2-wire), V.33 (4-wire)
- * Operates on a single +5 Volt supply
- * Standard Operating Temperature Range 0C to 70C
Optional operating range, -40C to 85C available

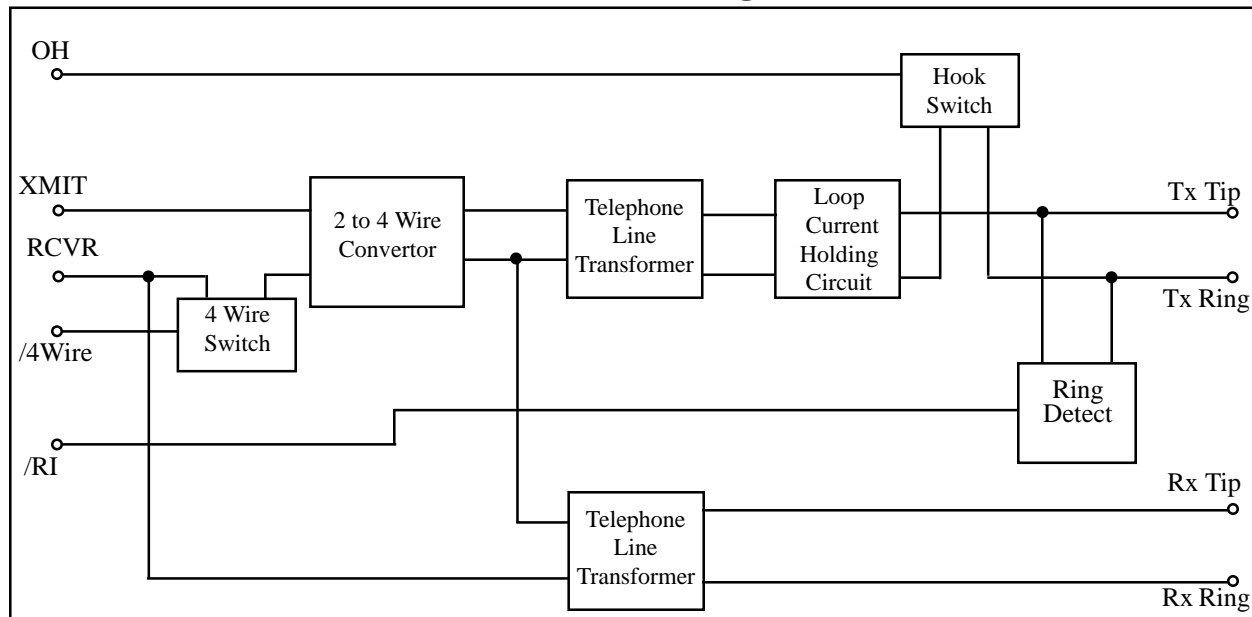
XE0204 Block Diagram

XE0204 Mechanical Specifications

Dim	Inches		Milimeters	
	Min	Max	Min	Max
A	1.480	1.520	37.59	38.61
B	1.060	1.100	26.92	27.94
C	0.420	0.430	10.67	10.92
D	0.890	0.910	22.61	23.11
E	0.890	0.910	22.61	23.11
F	0.125	-	3.18	-
G	0.040	0.060	1.02	1.52
H	0.290	0.310	7.37	7.87
J	0.090	0.110	2.29	2.79
K	0.020	0.025	0.51	0.64

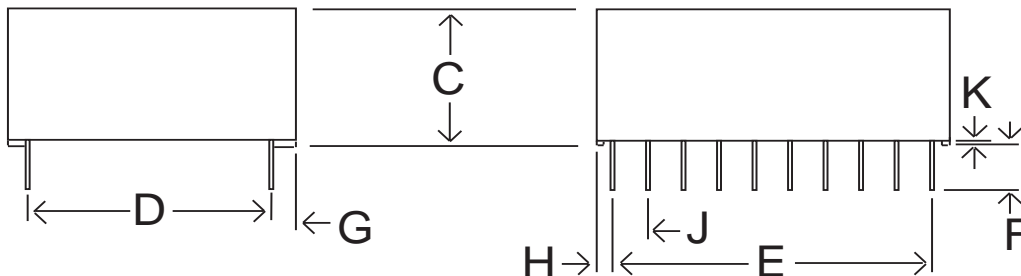
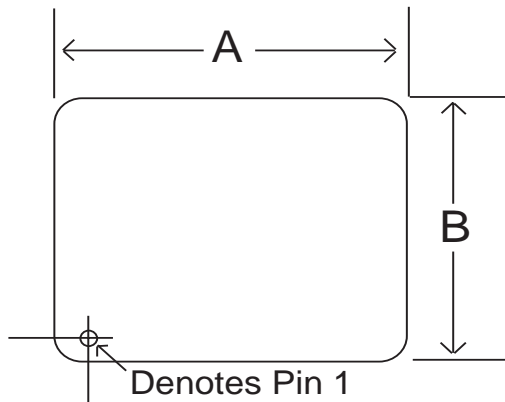

XE0204 Pin Configuration

XE0204 (Top View)			
VCC	○ 1		20 ○ TxTip
/RI	○ 3		17 ○ TxRing
RCVR	○ 4		
XMIT	○ 5		
OH	○ 7		14 ○ RxTip
/4Wire	○ 8		
N/C	○ 9		
Gnd	○ 10		11 ○ RxRing

XE0204 Pin Configuration

Pin	Name	Description
1	VCC	VCC supplies +5 Volts power to the XE0204
3	/RI	Ring Indicate, output, active low, TTL. /RI indicates the XE0204 is receiving a ring signal. /RI remains low for the duration of each ring.
4	RCVR	RCVR acts as the analog output for signals received from the telephone line by the XE0204. In two wire mode the received signal is placed on RCVR by the 2-to-4 wire convertor. In four wire mode the received signal comes directly from the receive phone line pair.
5	XMIT	XMIT provides the analog input to the XE0204 for signals to be transmitted onto the telephone line. In two wire mode the signal is passed to the 2-to-4 wire convertor. In four wire mode the signal goes directly the transmit phone line pair.
7	OH	Hookswitch relay control. A high on OH closes the internal relay and connects the equipment to the telephone line. OH must be forced high to maintain a 2 wire or 4 wire leased line.
8	/4Wire	/4Wire is an active low input to the XE0204 which selects four wire operation. If pin 8 is open or driven high, two wire mode is selected.
9	N/C	No Connection
10	Gnd	Gnd provides the ground reference connection to the XE0204.
11	RxRing	RxRing provides the Ring connection to the receive pair of the four wire phone line. RxRing is not used for two wire connections. RxRing has 1500 volts isolation from the rest of the circuitry. This isolation must be preserved throughout the system.
14	RxTip	RxTip provides the Tip Connection to the receive pair of the four wire phone line. RxTip is not used for two wire connections. TxTip has 1500 volts isolation from the rest of the circuitry. This isolation must be preserved throughout the system.
17	TxRing	TxRing provides the Ring Connection to two wire lines as well as to the transmit pair of four wire phone lines. TxRing has 1500 volts isolation from the rest of the circuitry. This isolation must be preserved throughout the system.
20	TxTip	TxTip provides the Tip Connection to two wire lines as well as to the transmit pair of four wire phone lines. TxTip has 1500 volts isolation from the rest of the circuitry. This isolation must be preserved throughout the system.

XE0204 Electrical Specifications (VCC= +5V ± 10%, Ta = 0C to 70C)

Parameter	Conditions	Min	Typ	Max	Units
Power Supply Current	4-Wire Operation		10	16	mA
Transmit Insertion loss	2-Wire line, 1000 Hz, 600 Ohm line	-0.5	0	0.5	dB
Receive Insertion Loss	2-Wire line, 1000 Hz, 600 ohm line 4-Wire line, 1000 Hz, 600 ohm line	-0.5	0 0.8	0.5 3.0	dB dB
Telephone Line Impedance	At 1800 Hz, (2 and 4 wire Lines)	540	600	660	Ohms
Coupler Match input Impedance	Output impedance driving RCVR in four-wire mode	531	536	541	Ohms
Transmit Input Impedance	At 1800 Hz	8	10	12	KOhms
Receive Output Impedance	2 Wire mode, 1800 Hz		10	100	Ohms
Transhybrid Loss	2-wire mode, 1 KHz, 600 ohm line	15	21		dB
Ring Detect Sensitivity	Type B Ringer	38		150	Vrms
Ring Indicate Output	Ring Voltage present on Tip and Ring		0.2	0.5	Volts
Hook Switch Control Voltage	ON: (off-hook) OFF: (on-hook)	4.0		0.8	Volts Volts
Hook Switch Control Current	Off-Hook	0.5			mA
/4WIRE Switch	2-Wire 4-Wire	4.0		0.8	Volts Volts
Loop Current, Tx Pair	Off-hook	0		100	mA
Loop Current, Rx Pair	4-Wire Line			0	mA

XE0204 Absolute Maximum Ratings

Supply Voltage - VCC	+6.5 Volts
Storage Temperature	-25°C to +85°C
Operating Temperature Range	0°C to +70°C
Maximum Lead Temperature (soldering 2 seconds per wave)	260°C

XE0204 Typical Connection Diagram for a 2-Wire, Dial-up Line

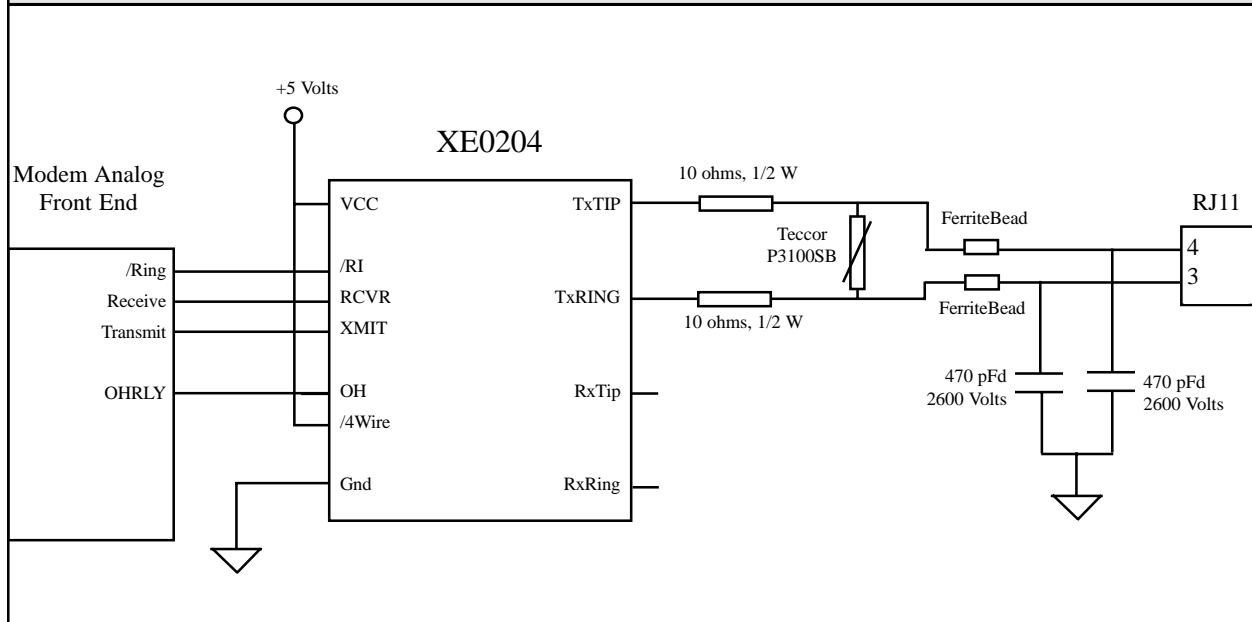

XE0204 Typical Connection Diagram for a 2-Wire, Leased Line

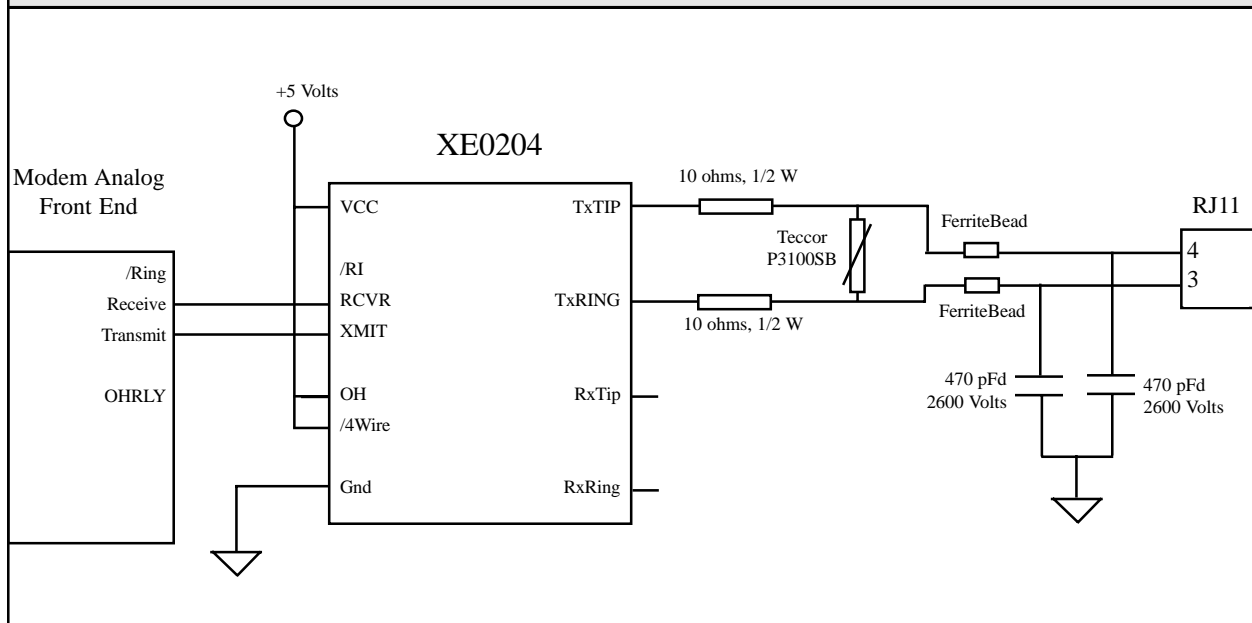

XE0204 Typical Connection Diagram for a 4-Wire, Leased Line

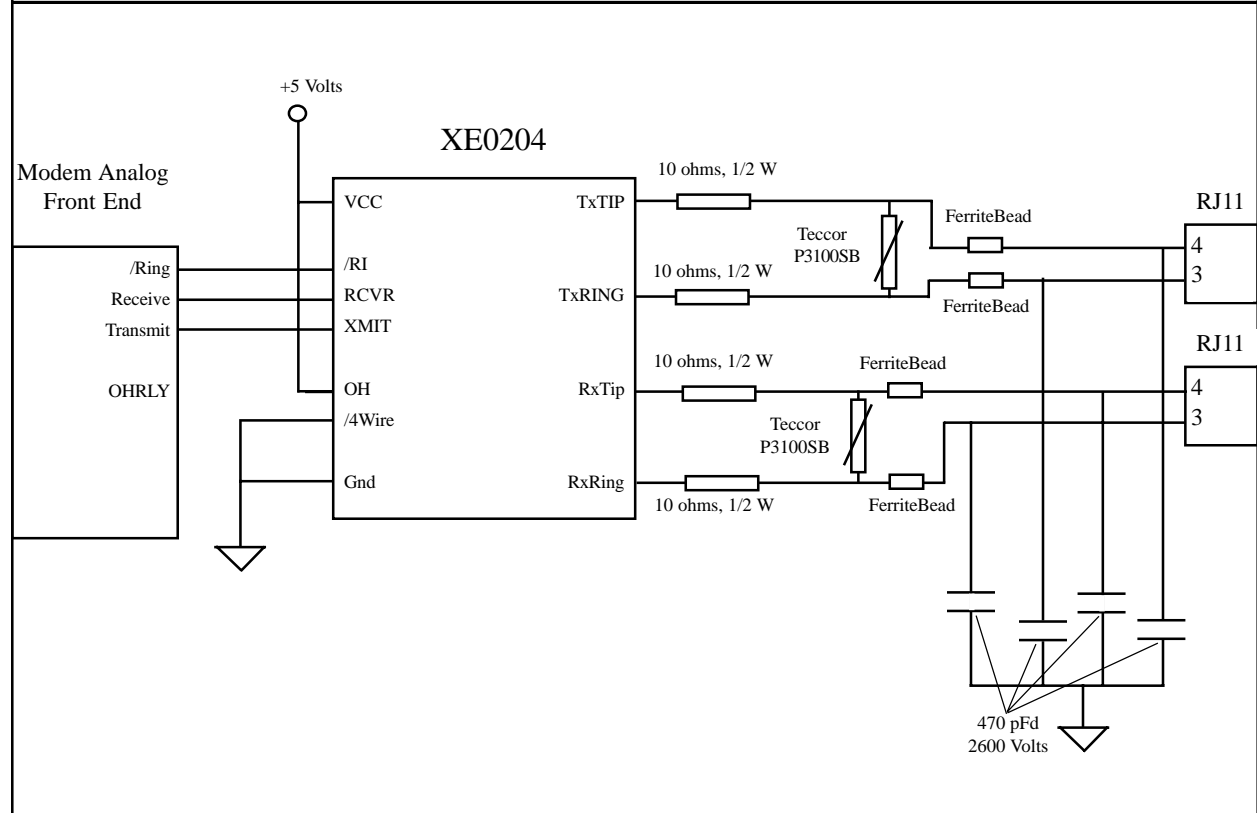

Recommended Parts

<u>Reference Designation</u>	<u>Recommended Part Number</u>
Ferrite Beads	TDK ACB2012L-120-X
High Voltage Capacitors	Panasonic ECKDRS471, 470 pfd, 2600 Volts
RJ11 Telephone Jack	Stewart SS6446NF

XE0204 FCC Instructions

When developing a product to be connected to the telephone line, it is necessary to use a circuit described as a Data Access Arrangement (DAA) which is approved by the appropriate governmental agency. In the US, for example, this agency is the Federal Communications Commission (FCC), while in Canada it is the Department of Communications (DOC). These agencies test and approve the product to ensure that it meets their specifications, thereby protecting the telephone system from damage and protecting the user from high voltage transients (such as lightning strikes) which may come down the telephone line.

The XE0204 has been designed to meet all FCC Part 68 requirements for hazardous voltage, surge protection and leakage current. If the system developed transmits data, or DTMF tones on the telephone line, the user must certify that the signals transmitted meet basic FCC requirements for maximum transmission levels, out of band energy and billing delay. Full details may be obtained from the FCC under Part 68 of the FCC Rules and Regulations, or in Title 47 of the Code of Federal Regulations, however the basic requirements are as follows:

1. Maximum Transmit Level

For the normal “permissive” (standard) telephone line, equipment which transmits data (such as a modem) must not exceed a transmission level of -9 dBm.

2. Out of Band Energy

Data equipment must not transmit “out of band” energy on the telephone line which exceeds the following limits:

Frequency		Range	Max. Power
200Hz	to	3990Hz	-9 dBm
3990Hz	to	4005Hz	-27 dBm
4005Hz	to	16kHz	-16 dBm
8kHz	to	94kHz	-47 dBm
86kHz	to	270kHz	-46 dBm
270kHz	to	6MHz	-6 dBm

3. DTMF Transmission Level

If the system is capable of DTMF dialing, the maximum DTMF transmission level must be less than 0 dBm averaged over a 3 second interval.

4. Billing Delay

A delay of 2 seconds or greater is required after the time the XE0204 is taken “off hook” and before any information is transmitted. This is required to ensure that billing information may be exchanged between telephone company central offices without interference.

The user of the XE0204 must certify to the FCC that the final system meets the requirements of Part 68 which include the criteria above as well as the high voltage protection provided by the XE0204. This is generally accomplished through an independent testing lab which tests the System and submits the proper paperwork to the FCC for approval. Since the X0204 already complies with FCC Part 68 rules, this is a relatively simple process.

Terms of Sale

Devices sold by XECOM are covered by the warranty provisions appearing in its Terms of Sale only. XECOM makes no warranty, express, statutory, implied, or by description regarding the information set forth herein, or regarding the freedom of the described devices from patent infringement. XECOM makes no warranty of merchantability or fitness for any purposes. XECOM reserves the right to discontinue production and change specifications and prices at any time and without notice. This product is intended for use in normal commercial applications. Applications requiring extended temperature range, unusual environmental requirements, or high reliability applications, such as military, medical life-support or life-sustaining equipment, are specifically not recommended without additional processing and authorization by XECOM for such application.

Xecom assumes no responsibility for the use of any circuitry other than circuitry embodied in a Xecom product. No other circuits, patents, or licenses are implied.

Life Support Policy

Xecom's products are not authorized for use as Critical Components in Life Support Devices or Systems.

Life Support Devices or Systems are devices or systems which, (a) are intended for surgical implant into the body, or (b) support or sustain life, and whose failure to perform, when properly used in accordance with instructions provided in the labeling, can be reasonably expected to result in significant injury to the user.

A **Critical Component** is any component of a life support device or system whose failure to perform can be reasonably expected to cause failure of the life support device or system, or to affect its safety or effectiveness.

Copyright, Xecom © 2000

While Xecom, Inc. has made every effort to ensure that the information presented here is accurate, Xecom will not be liable for any damages arising from errors or omission of fact. Xecom reserves the right to modify specifications and/or prices without notice. Product mentioned herein are used for identification purposes only and may be trademarks and/or registered trademarks of their respective companies.

The logo for Xecom, featuring the word "xecom" in a bold, lowercase, sans-serif font. The "x" is stylized with a horizontal bar through it. A registered trademark symbol (®) is located to the upper right of the "m".

Xecom Incorporated
374 Turquoise Street, Milpitas, CA 95035
Ph:408-945-6640 Fax:408-942-1346
Email: info@xecom.com