



NPN BUX11

HIGH CURRENT, HIGH SPEED , HIGH POWER TRANSISTOR

The BUX11 is silicon multiepitaxial planar NPN transistors in Jedec TO-3. They are intended for use in switching and linear applications in military and industrial equipments.
Compliance to RoHS.

ABSOLUTE MAXIMUM RATINGS

Symbol	Ratings		Value	Unit
V_{CEO}	Collector-Emitter Voltage	$I_B = 0$	200	V
V_{CBO}	Collector-Base Voltage	$I_E = 0$	250	V
V_{EBO}	Emitter-Base Voltage	$I_C = 0$	7.0	V
V_{CEX}	Collector-Emitter Voltage	$V_{BE} = -1.5V$	250	V
I_C	Collector Current		20	A
I_{CM}	Collector Peak Current	$t_p = 10ms$	25	A
I_B	Base Current		4	A
P_t	Total Power Dissipation	@ $T_C = 25^\circ$	150	W
T_J	Junction Temperature		200	$^\circ C$
T_{Stg}	Storage Temperature		-65 to +200	$^\circ C$

THERMAL CHARACTERISTICS

Symbol	Ratings	Value	Unit
R_{thJC}	Thermal Resistance, Junction to Case	1.17	$^\circ C/W$

NPN BUX11

ELECTRICAL CHARACTERISTICS

TC=25°C unless otherwise noted

Symbol	Ratings	Test Condition(s)	Min	Typ	Max	Unit
$V_{CEO(SUS)}$	Collector-Emitter Sustaining Voltage (*)	$I_C=200\text{ mA}$	200	-	-	V
$V_{EB0(SUS)}$	Emitter-Base Breakdown Voltage (*)	$I_C=0\text{ A}$, $I_E=50\text{ mA}$	7	-	-	V
I_{CEO}	Collector Cutoff Current	$V_{CE}=160\text{ V}$, $I_B=0\text{ A}$	-	-	1.5	mA
I_{CEX}	Collector Cutoff Current	$V_{CE}=V_{CEX}$, $V_{BE}=-1.5\text{ V}$	-	-	1.5	mA
		$V_{CE}=V_{CEX}$, $V_{BE}=-1.5\text{ V}$ $T_{case}=125^\circ\text{C}$	-	-	6	
I_{EBO}	Emitter Cutoff Current	$V_{EB}=5.0\text{ V}$, $I_C=0$	-	-	1	
h_{FE}	DC Current Gain (*)	$I_C=6\text{ A}$, $V_{CE}=2.0\text{ V}$	20	-	60	-
		$I_C=12\text{ A}$, $V_{CE}=4.0\text{ V}$	10	-	-	
$V_{CE(SAT)}$	Collector-Emitter saturation Voltage (*)	$I_C=6\text{ A}$, $I_B=0.6\text{ A}$	-	0.3	0.6	V
		$I_C=12\text{ A}$, $I_B=1.5\text{ A}$	-	0.6	1.5	
$V_{BE(SAT)}$	Base-Emitter saturation Voltage (*)	$I_C=12\text{ A}$, $I_B=1.5\text{ A}$	-	1.3	1.5	
$I_{S/B}$	Second breakdown collector current	$V_{CE}=30\text{ V}$, $t_s=1\text{ s}$	5	-	-	A
		$V_{CE}=140\text{ V}$, $t_s=1\text{ s}$	0.15	-	-	
$E_{S/B}$	Clamped $E_{S/B}$ Collector current	$V_{clamp}=200\text{ V}$, $L=500\text{ }\mu\text{H}$	12	-	-	
f_T	Transition frequency	$V_{CE}=15\text{ V}$, $I_C=1\text{ A}$ $f=10\text{ MHz}$	8	-	-	MHz
t_{on}	Turn-on time	$I_C=12\text{ A}$, $I_B=1.5\text{ A}$ $V_{CC}=150\text{ V}$	-	0.3	1.0	μs
t_s	Storage time	$I_C=12\text{ A}$, $V_{CC}=150\text{ V}$ $I_{B1}=-I_{B2}=1.5\text{ A}$	-	1.2	1.8	
t_f	File time		-	0.24	0.4	

(*) Pulse Duration = 300 μs , Duty Cycle $\leq 2\%$

NPN BUX11

MECHANICAL DATA CASE TO-3

DIMENSIONS (mm)		
	min	max
A	11	13.10
B	0.97	1.15
C	1.5	1.65
D	8.32	8.92
F	19	20
G	10.70	11.1
N	16.50	17.20
P	25	26
R	4	4.09
U	38.50	39.30
V	30	30.30

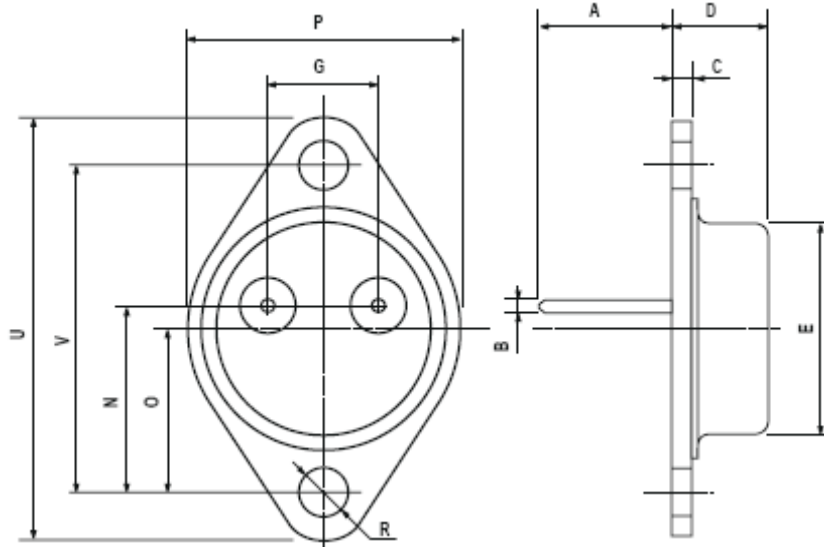

Pin 1 :	Base
Pin 2 :	Emitter
Case :	Collector

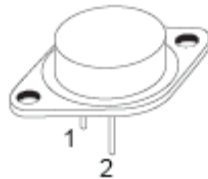

Revised September 2012

Information furnished is believed to be accurate and reliable. However, Comset Semiconductors assumes no responsibility for the consequences of use of such information nor for any infringement of patents or other rights of third parties which may result from its use. Data are subject to change without notice. Comset Semiconductors makes no warranty, representation or guarantee regarding the suitability of its products for any particular purpose, nor does Comset Semiconductors assume any liability arising out of the application or use of any product and specifically disclaims any and all liability, including without limitation consequential or incidental damages. Comset Semiconductors' products are not authorized for use as critical components in life support devices or systems.