

Service  
Service  
**Service**



# Service Manual

## TABLE OF CONTENTS

	Page
Location of PCBs .....	1-2
Version Variations & Package .....	1-2
Technical Specifications .....	1-3
Measurement Setup .....	1-4
Service Aids .....	1-5
ESD & Safety Instruction .....	1-6
System Setup & Controls .....	1-7 to 1-11
Troubleshooting .....	1-12
Repair Instructions .....	2-1 to 2-2
Disassembly Instructions & Service Positions .....	3-1 to 3-2
Set Block & Wiring Diagram .....	4
Key / Power Switch Board .....	5
Source + Phone / 6ch in Board .....	6
Power Board .....	7
Main Board .....	8
Set Mechanical Exploded View & Parts list .....	9



© Copyright 2001 Philips Consumer Electronics B.V. Eindhoven, The Netherlands  
 All rights reserved. No part of this publication may be reproduced, stored in a retrieval system or transmitted, in any form or by any means, electronic, mechanical, photocopying, or otherwise without the prior permission of Philips.

Published by SL-ET0316 Service Audio Printed in The Netherlands Subject to modification

3140 785 32480

Version 1.0



# PHILIPS

## LOCATION OF PCB BOARDS

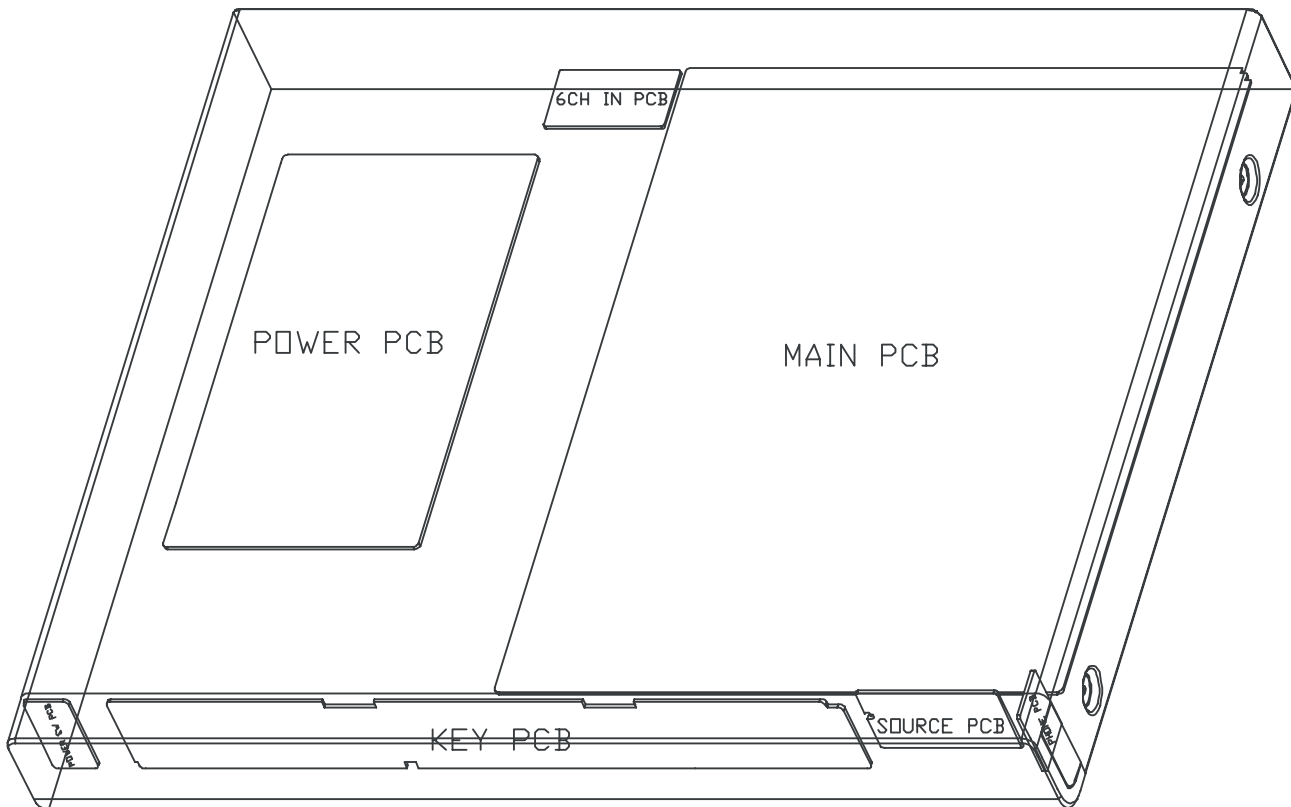

## VERSION VARIATION:

Features & Board in used	Type/Versions	LX700D	LX700D	LX700D
		/21S	/22S	/25S
RDS function			x	x
Grid Switch	By software			
Line Cord (Detachable)		x	x	x
Line Cord (Fixed)				
AC Voltage (110V~127V / 220~240V)		x		
AC Voltage (220V~240V)			x	x
AC Voltage Selector		x		

## SPECIFICATIONS

### AMPLIFIER SECTION

Power Output	
- Stereo mode (DIN).....	2 x 50 W
- Surround mode (1 kHz).....	.50 WRMS/channel
Total Harmonic Distortion.....	10 % at rated power (1 kHz)
Frequency Response .....	180 Hz-14 kHz/ 1 dB
Signal-to-Noise Ratio.....	> 65dB(CCIR)
Input Sensitivity.....	400 mV

### TUNER SECTION

Tuning Range.....	FM 87.5 -108 MHz
.....	MW 531 - 1602 kHz (9kHz steps)
.....	/22S/25S
.....	MW 530 - 1700 kHz (10kHz steps)
.....	/21S
26 dB Quieting Sensitivity.....	FM 20 dB
26 dB Quieting Sensitivity.....	MW3260uV/m
Image Rejection Ratio.....	FM 25 dB
.....	MW28 dB
IF Rejection Ratio.....	FM 60 dB
.....	MW24 dB
Signal-to-Noise Ratio.....	FM 55 dB
.....	MW35 dB
AM Suppression Ratio.....	FM 30 dB
Harmonic Distortion.....	FM Mono 3%
.....	FM Stereo 3%
.....	MW5%
Frequency Response.....	FM 180 Hz-10kHz/ 6 dB
Stereo Separation.....	FM 26 dB(1 kHz)
Stereo threshold.....	FM 23.5 dB

### MISCELLANEOUS / GENERAL SECTION

Power Supply Rating.....	220~240V/50Hz
.....	/22S/25S
.....	110~127V/220~240V, 50/60Hz
.....	/21S
Power Consumption.....	160 W
Dimensions (w x h x d).....	435 mm x 58 mm x 362mm
Weight.....	4.2 kg

### IR REMOTE CONTROL

Effective Range.....	> 8 Meter
Number of Keys.....	45
Battery (1.5V).....	AA x 2

### SPEAKERS

#### Front Speakers / Surround speaker

System.....	2-way shielded
Impedance/ohm.....	8Ω
Speaker drivers.....	.3" woofer, flat tw
Dimensions (w x h x d).....	89 mm x 270 mm x 41 mm
Weight.....	0.40 Kg

#### Center Speaker

System.....	2-way shielded
Impedance/ohm.....	8Ω
Speaker drivers.....	.3" woofer, flat tw
Dimensions (w x h x d).....	286 mm x 95 mm x 67 mm
Weight.....	0.88 Kg

### SUBWOOFER

Subwoofer (not magnetically shielded design).....	6.5"
Input power.....	100W (8Ω, DIN)
Dimensions (w x h x d).....	195 mm x 462 mm x 263 mm
Weight.....	5.5 Kg

# MEASUREMENT SETUP

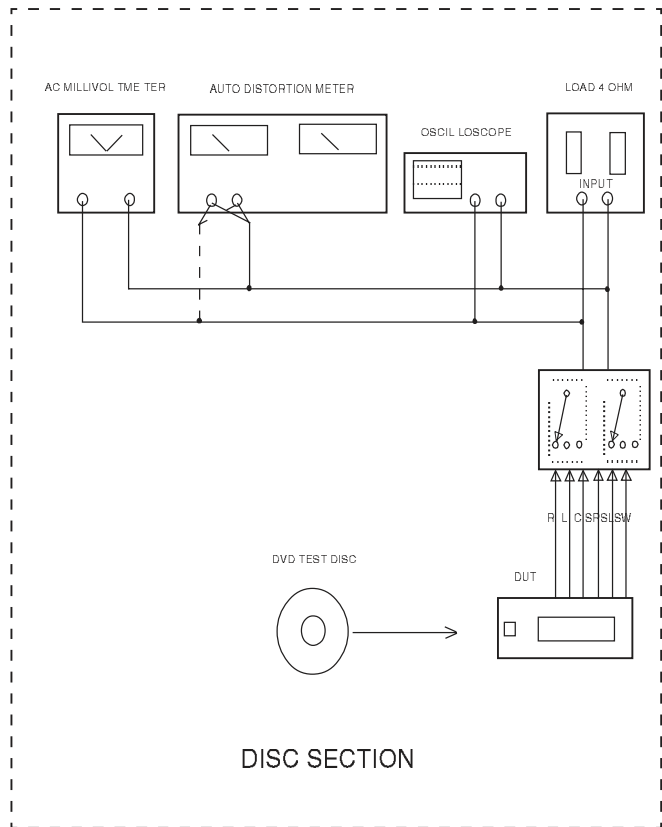
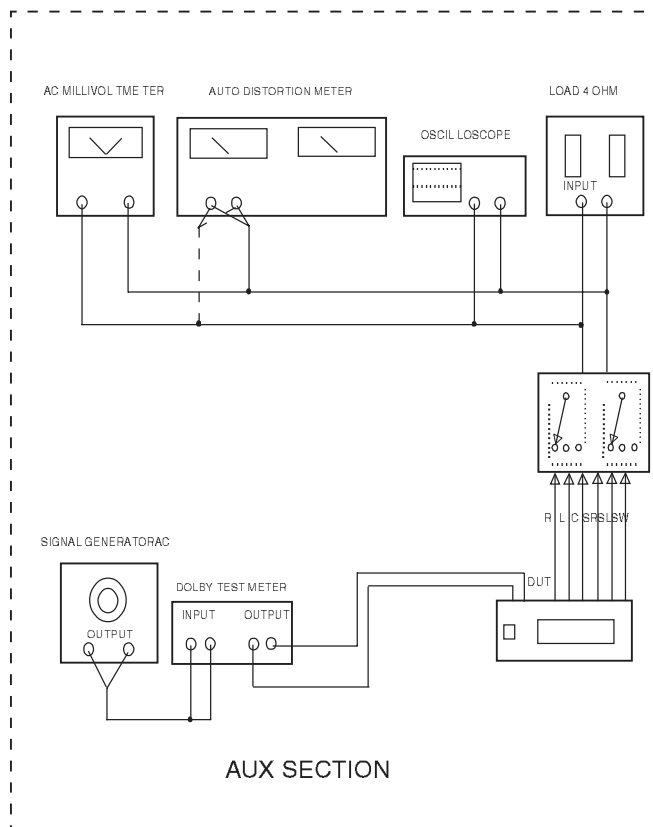
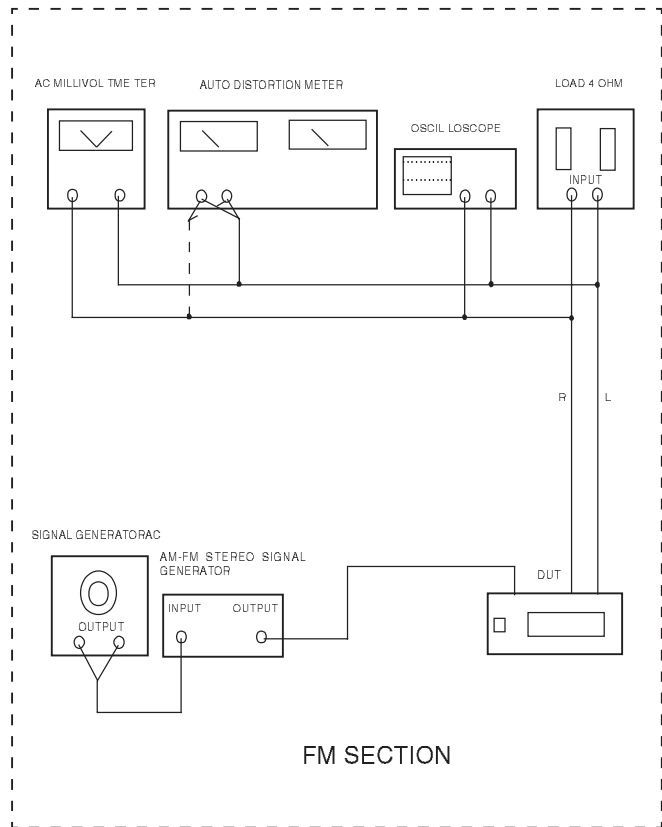
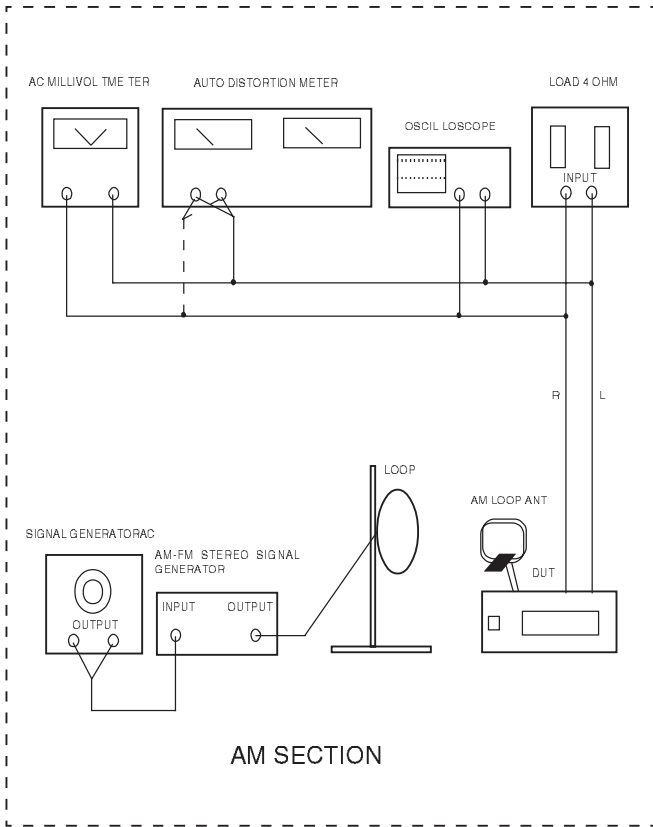

# SERVICE AIDS

## Service Tools:

Universal Torx driver holder .....	4822 395 91019
Torx bit T10 150mm .....	4822 395 50456
Torx driver set T6-T20 .....	4822 395 50145
Torx driver T10 extended .....	4822 395 50423

## Compact Disc:

SBC426/426A Test disc 5 + 5A .....	4822 397 30096
SBC442 Audio Burn-in test disc 1kHz .....	4822 397 30155
SBC429 Audio Signals disc .....	4822 397 30184
Dolby Pro-logic Test Disc .....	4822 395 10216

## ESD Equipment:

Anti-static table mat - large 1200x650x1.25mm ...	4822 466 10953
anti-static table mat - small 600x650x1.25mm ....	4822 466 10958
Anti-static wristband .....	4822 395 10223
Connectorbox (1M $\Omega$ ) .....	4822 395 11307
Extension cable (to connect wristband to conn.box) .....	4822 320 11305
Connecting cable (to connect table mat to conn.box) .....	4822 320 11306
Earth cable (to Connect product to mat or box) --	4822 320 11308
Complete kit ESD3 (combining all above products) .....	4822 320 10671
Wristband tester .....	4822 344 13999

## HANDLING CHIP COMPONENTS

### GENERAL

### DISMOUNTING

**A**

**B**

**C**

### MOUNTING

**A**

**B**

### EXAMPLES

### PRECAUTIONS

**GB** WARNING

All ICs and many other semi-conductors are susceptible to electrostatic discharges (ESD). Careless handling during repair can reduce life drastically.

When repairing, make sure that you are connected with the same potential as the mass of the set via a wrist wrap with resistance.

Keep components and tools also at this potential.

**ESD****NL** WAARSCHUWING

Alle IC's en vele andere halfgeleiders zijn gevoelig voor electrostatische ontladingen (ESD).

Onzorgvuldig behandelen tijdens reparatie kan de levensduur drastisch doen verminderen.

Zorg ervoor dat u tijdens reparatie via een polsband met weerstand verbonden bent met hetzelfde potentiaal als de massa van het apparaat.

Houd componenten en hulpmiddelen ook op hetzelfde potentiaal.

**F** ATTENTION

Tous les IC et beaucoup d'autres semi-conducteurs sont sensibles aux décharges statiques (ESD).

Leur longévité pourrait être considérablement écourtée par le fait qu'aucune précaution n'est prise à leur manipulation.

Lors de réparations, s'assurer de bien être relié au même potentiel que la masse de l'appareil et enfilez le bracelet serti d'une résistance de sécurité.

Veiller à ce que les composants ainsi que les outils que l'on utilise soient également à ce potentiel.

**D** WARNUNG

Alle ICs und viele andere Halbleiter sind empfindlich gegenüber elektrostatischen Entladungen (ESD).

Unvorsichtige Behandlung im Reparaturfall kann die Lebensdauer drastisch reduzieren.

Veranlassen Sie, dass Sie im Reparaturfall über ein Pulsarmband mit Widerstand verbunden sind mit dem gleichen Potential wie die Masse des Gerätes.

Bauteile und Hilfsmittel auch auf dieses gleiche Potential halten.

**I** AVVERTIMENTO

Tutti IC e parecchi semi-conduttori sono sensibili alle scariche statiche (ESD).

La loro longevità potrebbe essere fortemente ridatta in caso di non osservazione della più grande cauzione alla loro manipolazione.

Durante le riparazioni occorre quindi essere collegato allo stesso potenziale che quello della massa dell'apparecchio tramite un braccialetto a resistenza.

Assicurarsi che i componenti e anche gli utensili con quali si lavora siano anche a questo potenziale.

**GB**

Safety regulations require that the set be restored to its original condition and that parts which are identical with those specified, be used.

"Pour votre sécurité, ces documents doivent être utilisés par des spécialistes agréés, seuls habilités à réparer votre appareil en panne".

**NL**

Veiligheidsbepalingen vereisen, dat het apparaat bij reparatie in zijn oorspronkelijke toestand wordt teruggebracht en dat onderdelen, identiek aan de gespecificeerde, worden toegepast.

**F**

Les normes de sécurité exigent que l'appareil soit remis à l'état d'origine et que soient utilisées les pièces de rechange identiques à celles spécifiées.

**D**

Bei jeder Reparatur sind die geltenden Sicherheitsvorschriften zu beachten. Der Originalzustand des Geräts darf nicht verändert werden; für Reparaturen sind Original-Ersatzteile zu verwenden.

**I**

Le norme di sicurezza esigono che l'apparecchio venga rimesso nelle condizioni originali e che siano utilizzati i pezzi di ricambio identici a quelli specificati.

"After servicing and before returning set to customer perform a leakage current measurement test from all exposed metal parts to earth ground to assure no shock hazard exist. The leakage current must not exceed 0.5mA."

# Connections

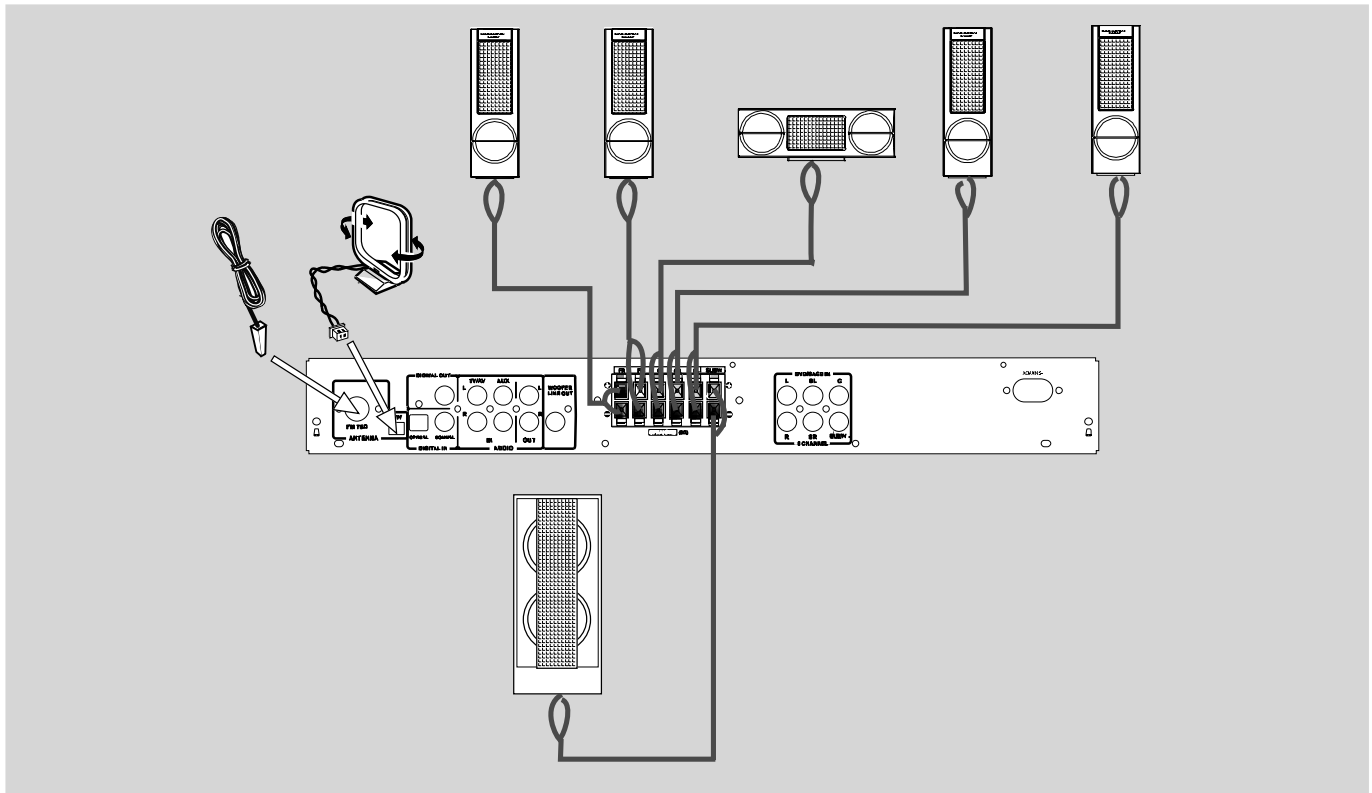

### IMPORTANT!

- Before connecting the AC power cord to the wall outlet, ensure that all other connections have been made.
- Never make or change any connections with the power switched on.
- The type plate is located at the rear of the system.

### Before connecting the speakers:

- Mount the speakers onto the mini speaker stands as shown in the illustration.
- Remove the protective cover only after the connection and installation of speakers are completed.

Connect the supplied speaker system using the supplied speaker cable by matching the colors of the jacks and speaker cable.

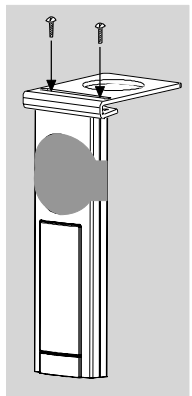

## Connecting the speakers

Press up (or down) the speaker's jack and fully insert the stripped portion of the speaker cable into the jack, then release.

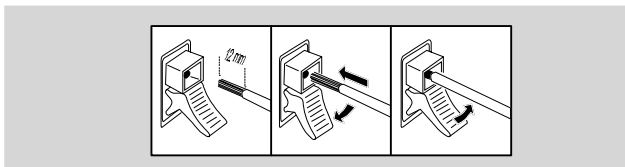

### Notes:

- Check the speaker cables are correctly connected. Improper connections may damage the system due to short-circuit.
- For optimal sound performance, use the supplied speakers.
- Do not connect more than one speaker to any one pair of +/- speaker jacks.
- Do not connect speakers with impedance lower than the speakers supplied. Please refer to the SPECIFICATION section of this manual.

Speakers	⊖	+ ⊕
Front Left (L)	black	white
Front Right (R)	black	red
Center	black	green
Surround (Rear) Left (L)	black	blue
Surround (Rear) Right (R)	black	grey
Passive Subwoofer	black	purple

# Connections

## Connecting antennas

### MW Indoor Loop Antenna

Connect the supplied MW loop antenna to the **MW** jack. Position the loop antenna to receive the clearest sound.

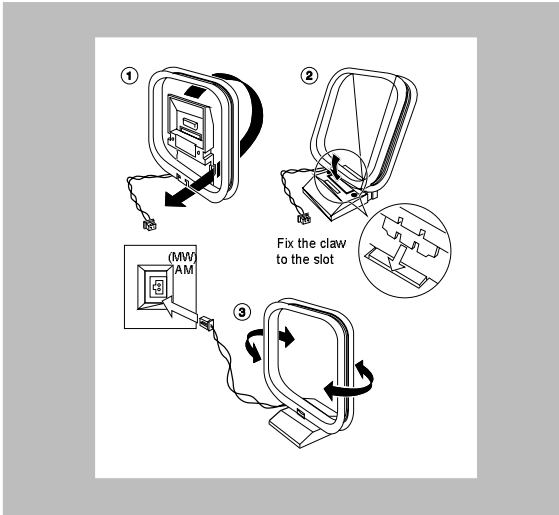

### FM Indoor Antenna

Connect the supplied FM antenna to the **FM** jack. Move the antenna in various directions until the clearest signal is received.

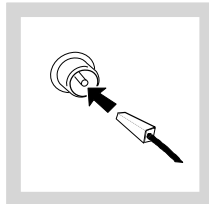

#### Note:

– Keep the antenna as far away as possible from the TV, VCR or any radiation source to prevent unwanted noise.

### FM Outdoor Antenna

For better FM reception, use a 75 ohm coaxial cable (not supplied) to connect the system to an outdoor FM antenna as shown.

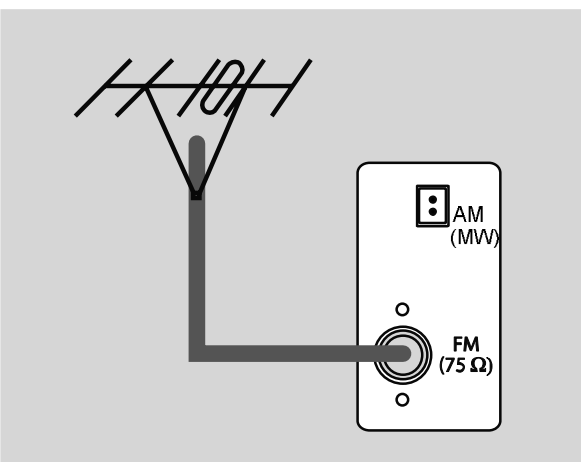

## Connecting from a DVD and additional components

To listen to playback from your **DVD** or **SACD** player:

### Option 1

#### 6 CHANNEL-DVD/SACD IN

Use the supplied audio cables to connect the **6 CHANNEL-DVD/SACD IN** jacks to the corresponding Multichannel **AUDIO OUT** on your **DVD** or **SACD** player.

#### About 6 CHANNEL-DVD/SACD IN

The **6 CHANNEL-DVD/SACD IN** can be used to connect from a device with a built-in multichannel decoder (e.g. Dolby, Digital, DTS, etc) and 6-channel output, i.e. a high end **DVD/SACD** player

When using the **6 CHANNEL-DVD/SACD IN** audio input, the Receiver works as a multichannel amplifier. The source reproduces surround sound and sends it to the Receiver divided into the necessary channels. Therefore the **SURROUND** button has no effect since the provided signal is already multichannel.

From a source which is connected to the **6 CHANNEL-DVD/SACD IN**, audio input cannot be recorded.

### OR

### Option 2

#### DIGITAL IN

Connect the **OPTICAL** or **COAXIAL** jack to the **DIGITAL OUT** jack on the **DVD** or **SACD** player. You will need to set the Receiver's digital input to the jack you connected to (refer to "System Setup - Digital Input")

### Connecting additional components

For listening to the playback from other audio/ visual devices through the Receiver

- Connect the **AUDIO IN (TV/AV or AUX)** jacks to the **AUDIO OUT** jacks on the **TV, VCR** or other audio/visual device.

### AND/OR

- Connect the **DIGITAL IN (OPTICAL or COAXIAL)** jack to the **DIGITAL OUT** jack on other audio/ visual device. You will need to set the Receiver's digital input to the jack you connected to ( refer to "System Setup - Digital Input").

### For recording to an external recording device

- Connect the **AUDIO OUT** jacks to the **AUDIO IN** jacks on an analog recording device.

### AND/OR

- Connect the **DIGITAL OUT** jack to the **DIGITAL IN** jack on a digital recording device. You can only make a digital recording from digital signal received from the **DIGITAL IN** jack on this receiver.



## Connections

### Notes:

- If the audio format of the digital input does not match the capabilities of your Receiver, it will produce a strong distorted sound or no sound at all
- Always refer to the instruction manual of the connected equipment to make an optimal connection

### Recording from the digital output

It is possible to connect a digital recorder to the digital output of the receiver. In this way, all signals coming from the digital inputs can be recorded directly on the connected audio recorder.

The receiver can be used to record digital sound audio signal from DVD to CD-R.

### Notes:

- Dolby Digital, DTS or MPEG signal are not possible to record from this receiver.
- Digital recording is not possible when the digital source material is copy-protected.

## Inserting batteries into the remote control

- Open the battery compartment.
- Place the batteries in the compartment with the correct polarity as indicated by '+' and '-' symbols.
- Close the cover.

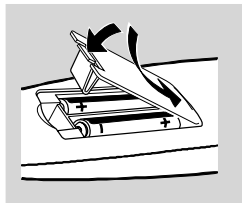

### CAUTION!

- Remove batteries if they are exhausted or will not be used for a long time.
- Do not use old and new or different types of batteries in combination.
- Batteries contain chemical substances, so they should be disposed off properly.

## Setting up the surround sound system

You must connect all the speakers and set up the system properly in order to enjoy the Digital Cinema experience at home (refer to "Connections - Connecting the speakers"). You will have the feeling of being in the middle of the action because sound is coming from everywhere around you. The subwoofer can enhance the bass performance of your system dramatically.

### IMPORTANT!

**Please sit at your usual listening position in order to set up the speaker balance correctly.**

### Placing the speakers

To obtain the best surround effect, place the speaker as follows.

## Preparations

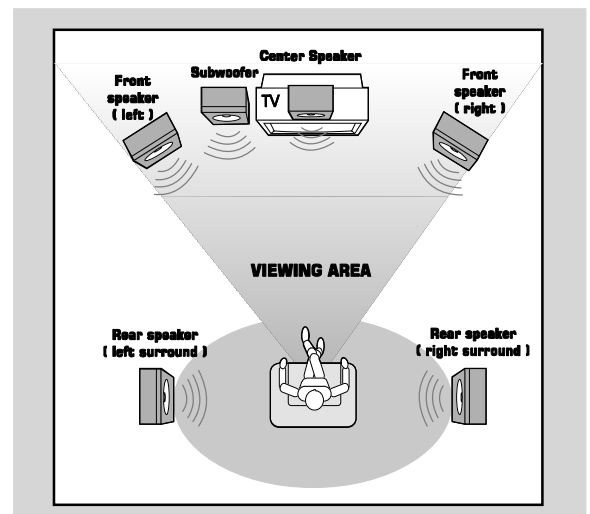

- 1 Place the front left and right speakers at equal distances from the TV and at an angle of approximately 45 degrees from the listening position.
- 2 Place the center speaker above or below the TV, so the center channel's sound is localized.
- 3 Place the surround speakers at normal listening ear level facing each other or mounted on the wall.
- 4 Place the subwoofer on the floor near to the TV.

### Notes:

- To avoid magnetic interference, do not position the front speakers too close to your TV.
- If the rear surround speakers are installed farther away from the listening position than the front and center speakers, it will weaken the surround effect.
- All speakers should be securely installed to prevent accidents and improve sound quality.

## Switching on the system

- 1 After completing all the connections, connect the AC power cord of the Receiver to the wall outlet. The system will go into STANDBY mode.
- 2 Press **STANDBY ON** to switch on the last selected source.
- 3 Rotate the **SOURCE** button or press **TV/AV, DISC, TUNER** or **AUX** on the remote control to select the input source.
  - The selected source will be displayed.

# Functional Overview

## Front and Rear panels

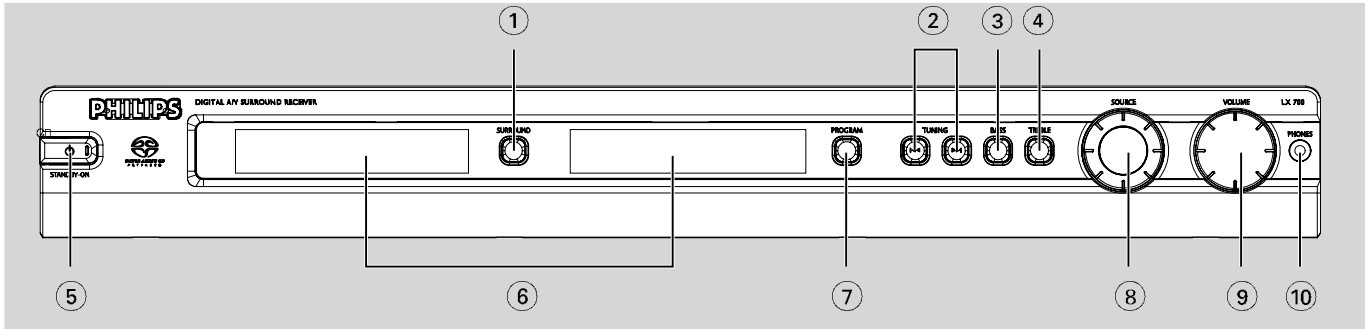

### ① SURROUND

- to select multichannel surround (Dolby Digital, DTS, Dolby Pro Logic or Dolby Pro Logic II) or stereo sound effect.

### ② TUNING |◀▶|

- to select the tuner frequency.

### ③ BASS

- to select bass adjustment mode.

### ④ TREBLE

- to select treble adjustment mode.

### ⑤ STANDBY ON ⏻

- to switch between power on and standby mode.

### ⑥ DISPLAY SCREEN

- shows the status of the system.

### ⑦ PROGRAM

- in Tuner mode, to program MW/FM stations.

### ⑧ SOURCE

- to select the desired source or external input source (TV/AV, DISC DI, DISC 6CH, TUNER or AUX).

### ⑨ VOLUME

- to adjust the master volume.

### ⑩ PHONE

- to connect headphones.

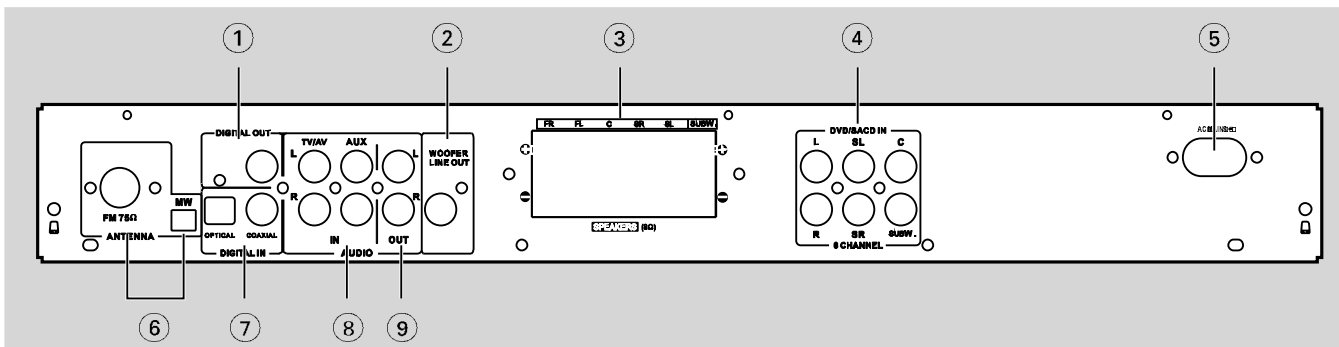

### ① DIGITAL OUT

- connect to the digital inputs of an external audio equipment.
- is active only when receiving input from DIGITAL IN (Coaxial or Optical).

### ② WOOFER LINE OUT

- connect to an active subwoofer (optional).

### ③ SPEAKERS

- connect to the front, center, surround and subwoofer speakers.

### ④ DVD/SACD IN

- connect from the 6 channel output of a DVD or SACD player.

### ⑤ AC POWER CORD

- connect to a standard AC outlet.

### ⑥ MW / FM

- connect to the MW loop antenna or FM antenna

### ⑦ DIGITAL IN

- connect from audio equipment with digital (Coaxial or Optical) audio output.

### ⑧ AUDIO IN (TV/AV, AUX)

- connect from the analog audio outputs of a TV or other equipment.

### ⑨ AUDIO OUT

- connect to the analog audio inputs of an external recording device or amplifier.

**Caution: Do not touch the inner pins of the jacks on the rear panel. Electrostatic discharge may cause permanent damage to the unit.**

# Functional Overview

## Remote control

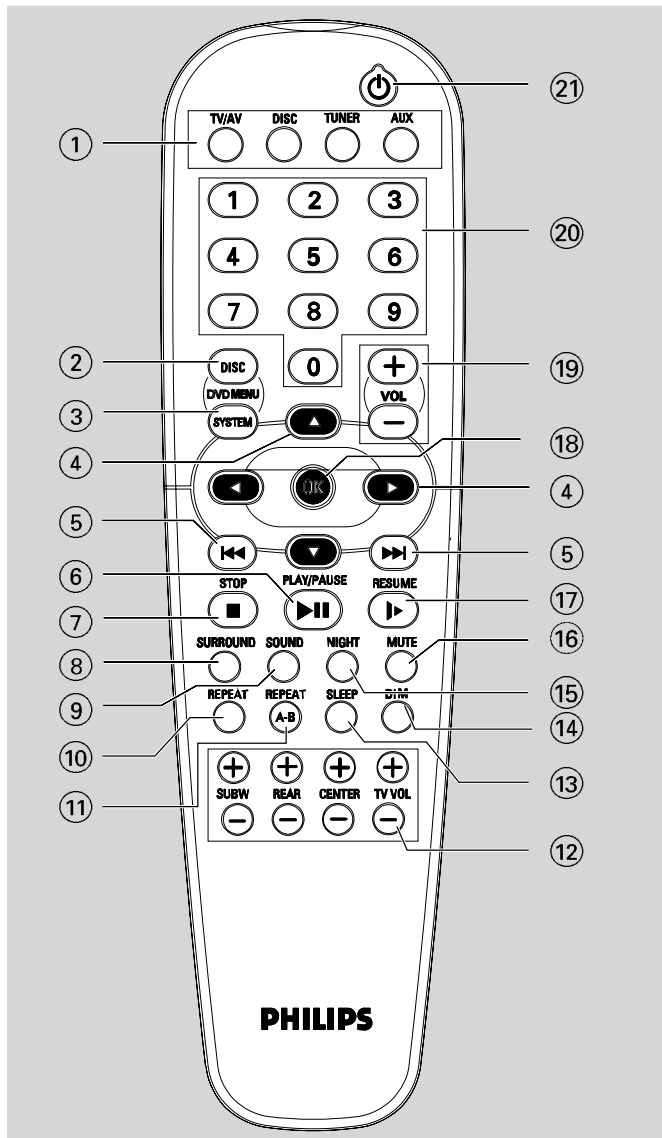

### Notes:

– The keys in the following list operate exclusively for this Receiver only.

- ① **SOURCE**  
– to select the desired source (TV/AV, DISC, TUNER or AUX).
- ④ ◀ ▶  
– Press ◀/▶ to select a preset radio station.
- ⑤ |◀◀ / ▶▶|  
– in Tuner mode, to tune to a lower or higher radio frequency.
- ⑧ **SURROUND**  
– to select multichannel surround (Dolby Digital, DTS or Dolby ProLogic II) or stereo sound effect.
- ⑨ **SOUND**  
– to select the various soundfield effects: CONCERT,

DRAMA, ACTION, SCI-FI, CLASSIC, JAZZ, ROCK or DIGITAL.

- ⑫ **SUBW +/–**  
– to adjust the subwoofer's level.
- REAR +/–**  
– to adjust the surround speakers' level.
- CENTER +/–**  
– to adjust the center speaker's level.
- TV +/–**  
– to adjust Philips's television volume level.
- ⑬ **SLEEP**  
– to set the sleep (auto-off) timer function.
- ⑭ **DIM**  
– to select different brightness for the display screen.
- ⑮ **MUTE**  
– to interrupt or resume sound reproduction.
- ⑯ **NIGHT (Dolby Digital mode only)**  
– to optimise the dynamics of the sound output.
- ⑰ **VOL +/–**  
– to adjust the volume level.
- ⑳ **Numeric Keypad (0-9)**  
– to enter the number of a preset radio station.
- ㉑ ⏻  
– to switch to standby mode.

### Notes:

The following keys only operate for a Philips DVD player. For details, please refer to a Philips DVD player instruction manual.

- ② **DISC - DVD MENU**  
– to enter or exit the disc contents menu.
- ③ **SYSTEM - DVD MENU**  
– to enter or exit the system menu bar.
- ⑥ ▶ ||  
– to start or interrupt disc playback.
- ⑦ ■  
– to stop playing the disc.
- ⑩ **REPEAT**  
– to repeat chapter, track or disc.
- ⑪ **REPEAT A-B**  
– to repeat a specific section on a disc.
- ⑰ **RESUME**  
– to continue disc playback after an interruption.
- ⑱ **OK**  
– to exit or confirm the selection.

# Troubleshooting

## WARNING!

Under no circumstances should you try to repair the system yourself, as this will invalidate the warranty. Do not open the system as there is a risk of electric shock.

If a fault occurs, first check the points listed below before taking the system for repair. If you are unable to solve a problem by following these hints, consult your dealer or service center.

Problem	Solution
<b>No power.</b>	<ul style="list-style-type: none"> <li>– Check the connection to the AC power cord.</li> </ul>
<b>No sound or distorted sound from speakers</b>	<ul style="list-style-type: none"> <li>– Check the connection to the speakers.</li> <li>– Adjust the volume.</li> <li>– Select the source you wish to listen to.</li> <li>– If the muting is on, press the MUTE button.</li> <li>– Replace the speaker cables.</li> </ul>
<b>No sound is heard from center or rear speakers</b>	<ul style="list-style-type: none"> <li>– Check the connections to the speakers.</li> <li>– Use the CENTER +/- or REAR +/- to adjust the volume level.</li> <li>– Check the speaker settings are connect correctly.</li> </ul>
<b>No sound from subwoofer.</b>	<ul style="list-style-type: none"> <li>– Check the connections to the subwoofer.</li> <li>– Play the bass source.</li> </ul>
<b>Noise interference</b>	<ul style="list-style-type: none"> <li>– The unit is too close to a TV set or other electrical appliances, relocate the unit, or turn off other appliances.</li> </ul>
<b>Sound cuts off during listening to music</b>	<ul style="list-style-type: none"> <li>– The positive and negative speaker cords may have short-circuited. Turn off the power and check the speaker cords.</li> <li>– Turn off the power and turn it on again, then reduce the volume.</li> </ul>
<b>Sound from the left and right speaker is reversed</b>	<ul style="list-style-type: none"> <li>– Check that the left and right speakers are not positioned in reverse order.</li> <li>– Check the left and right speakers cables are not connected to the terminals in reverse order.</li> </ul>
<b>Considerable noise in radio broadcasts.</b>	<ul style="list-style-type: none"> <li>– Tune to the correct frequency.</li> <li>– Connect the antenna.</li> <li>– Route all connection cables away from the antenna terminals and wires.</li> <li>– Fully extend the FM wire antenna. Position for best reception and secure to a wall.</li> <li>– Connect an outdoor FM or MW antenna.</li> <li>– Adjust the direction and position for best reception.</li> <li>– Turn off the equipment causing the noise.</li> <li>– Place the antenna farther away from the equipment causing the noise.</li> </ul>
<b>The remote control does not function.</b>	<ul style="list-style-type: none"> <li>– Point the remote control at the remote sensor of the unit.</li> <li>– Reduce the distance to the Receiver.</li> <li>– Remove any possible obstacles.</li> <li>– Replace the batteries with new ones.</li> <li>– Check that the batteries are loaded correctly.</li> <li>– Insert the mains plug into an outlet and press the main unit STANDBY ON <math>\phi</math> button.</li> </ul>
<b>Can't set NIGHT mode</b>	<ul style="list-style-type: none"> <li>– Play a source with DOLBY DIGITAL 5,1 channel sound.</li> <li>– Select a source (OPTICAL or COAXIAL) connected by digital cable correctly.</li> </ul>
<b>The display is dark</b>	<ul style="list-style-type: none"> <li>– Press DIM again.</li> </ul>
<b>Low bass response</b>	<ul style="list-style-type: none"> <li>– Check all speakers for correct polarity.</li> </ul>
<b>Can't select DTS mode</b>	<ul style="list-style-type: none"> <li>– Check the source's sound output setting and turn on DTS output.</li> <li>– Play a source with DTS sound.</li> <li>– Select a OPTICAL or COAXIAL source connected by digital cable.</li> </ul>

REPAIR INSTRUCTION

MAIN UNIT REPAIR CHART

- A  
All Function  
No Working
- B  
Power Supply  
No Working
- C  
AUX/TV Output  
No Sound
- D  
6 CH IN  
No Sound
- E  
Tuner  
No Sound
- F  
Digital IN  
No Sound
- G  
Digital IN  
No Output
- H  
Ear Head Phone  
No Sound
- I  
Subwoofer Line  
No Output
- J  
Audio Line  
No Output

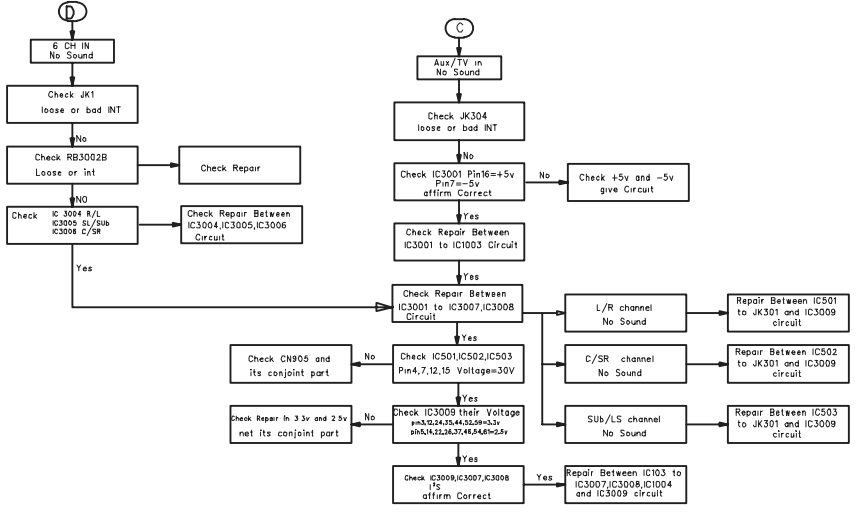
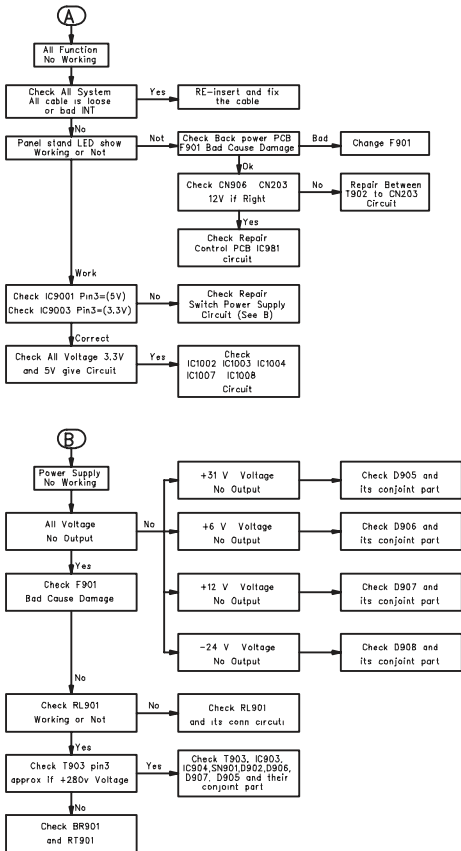

REPAIR INSTRUCTION

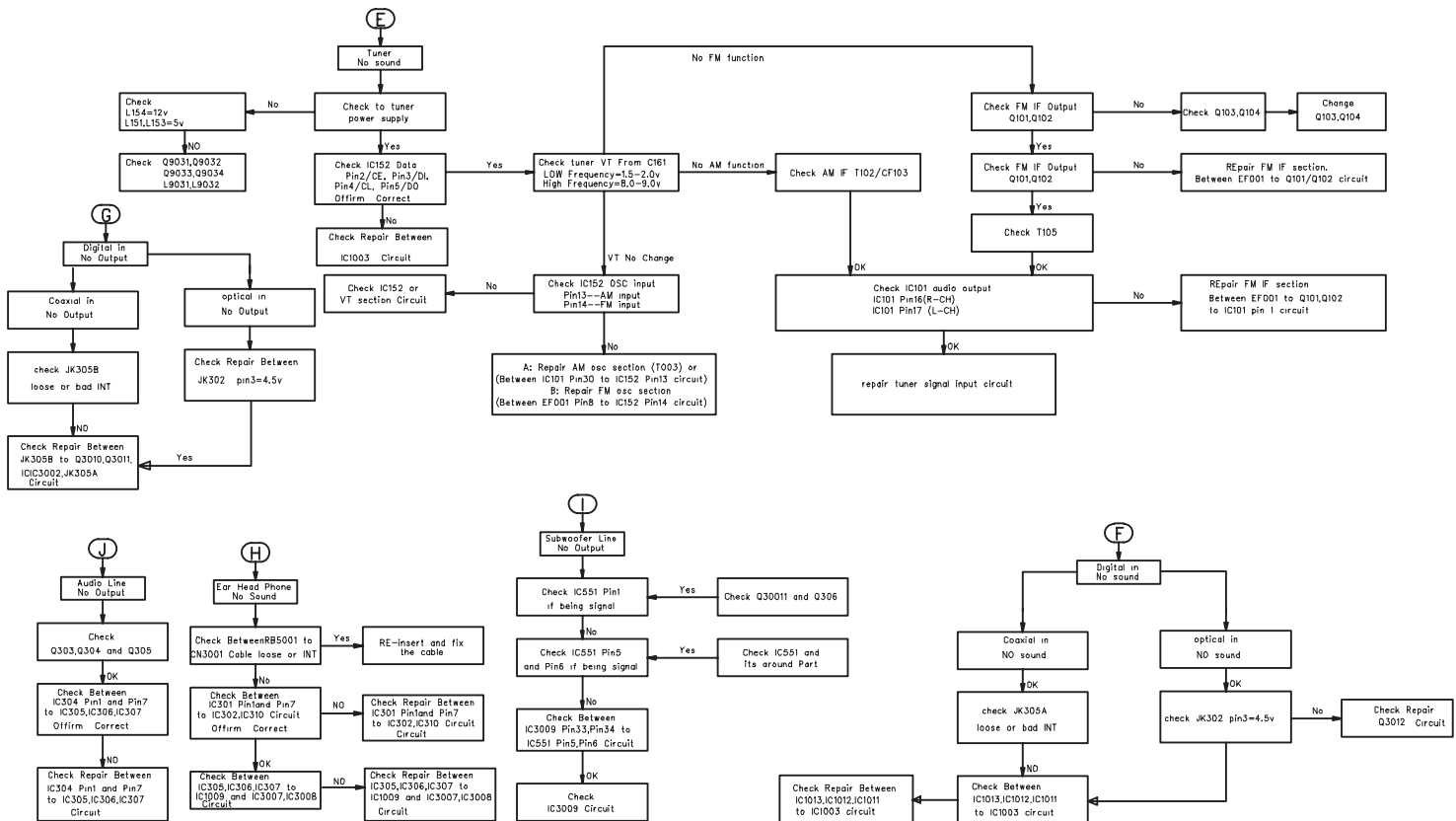

## DISASSEMBLY INSTRUCTIONS

- 1) Loosen 9 screws and remove the Top Cover by lifting the rear portion upwards before sliding it out towards the rear.
  - 5 screws on the back
  - 2 screws each on the left & right side
- 2) Loosen 7 screws & lift up the top edge of Front Panel assembly to free some catches before sliding it out towards the front.
  - 4 screws on the bottom
  - 1 screw "A" on the inside as indicated in Figure 1.
  - 1 screw each on the left & right side

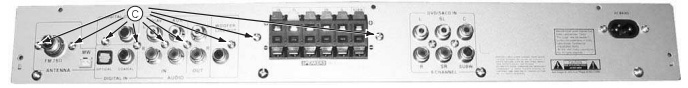

Figure 2

### Dismantling of the Main Board

- 1) Loosen 6 screws "B" on the top of main board as shown in figure 1.
- 2) Loosen 9 screws "C" at the back panel as shown in figure 2.

### Dismantling of the PowerBoard

- 1) Loosen 4 screws "d" on the top of power board as shown in figure 3.

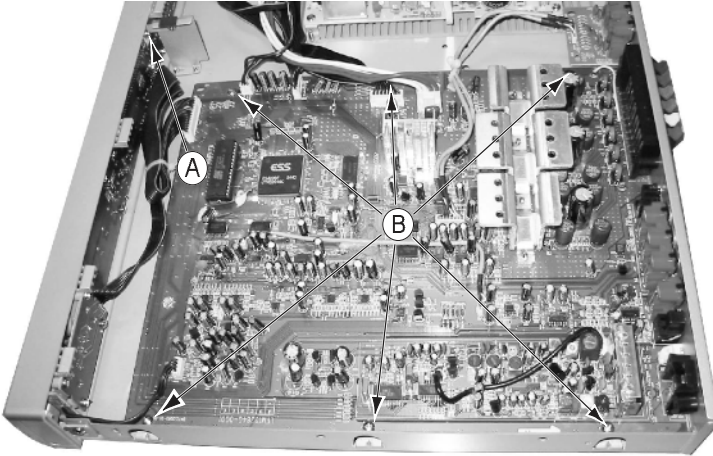

Figure 1

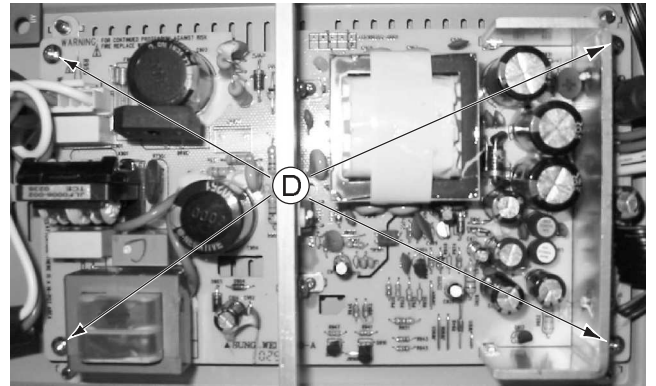
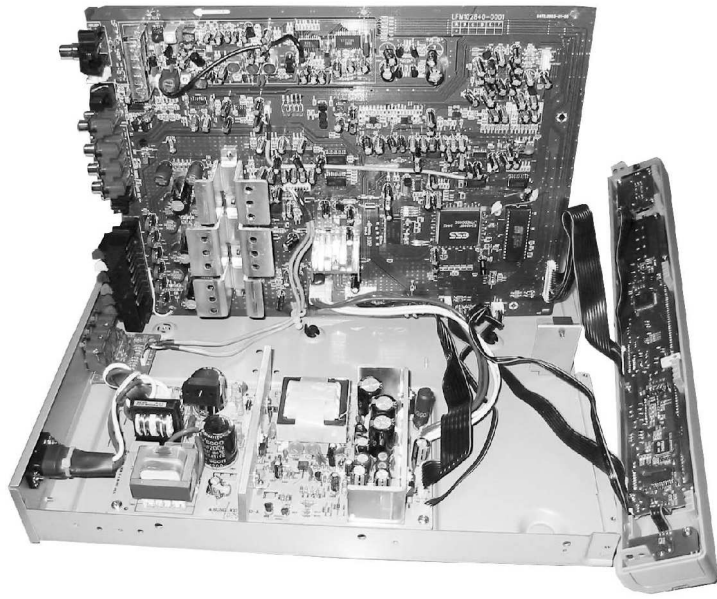

Figure 2

### SERVICE POSITIONS

Service position A



Service position B

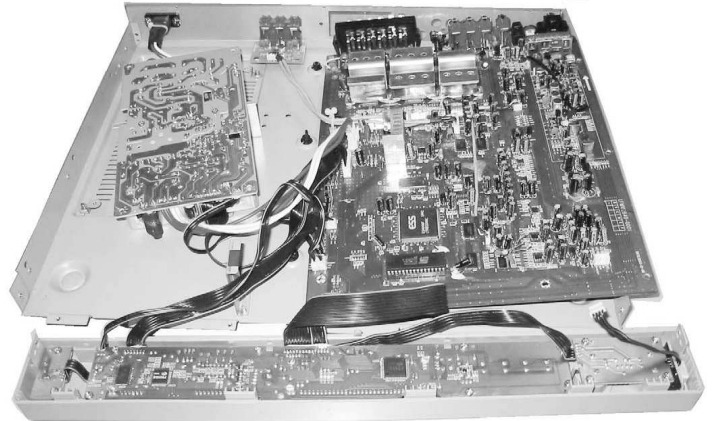



# BLOCK DIAGRAM

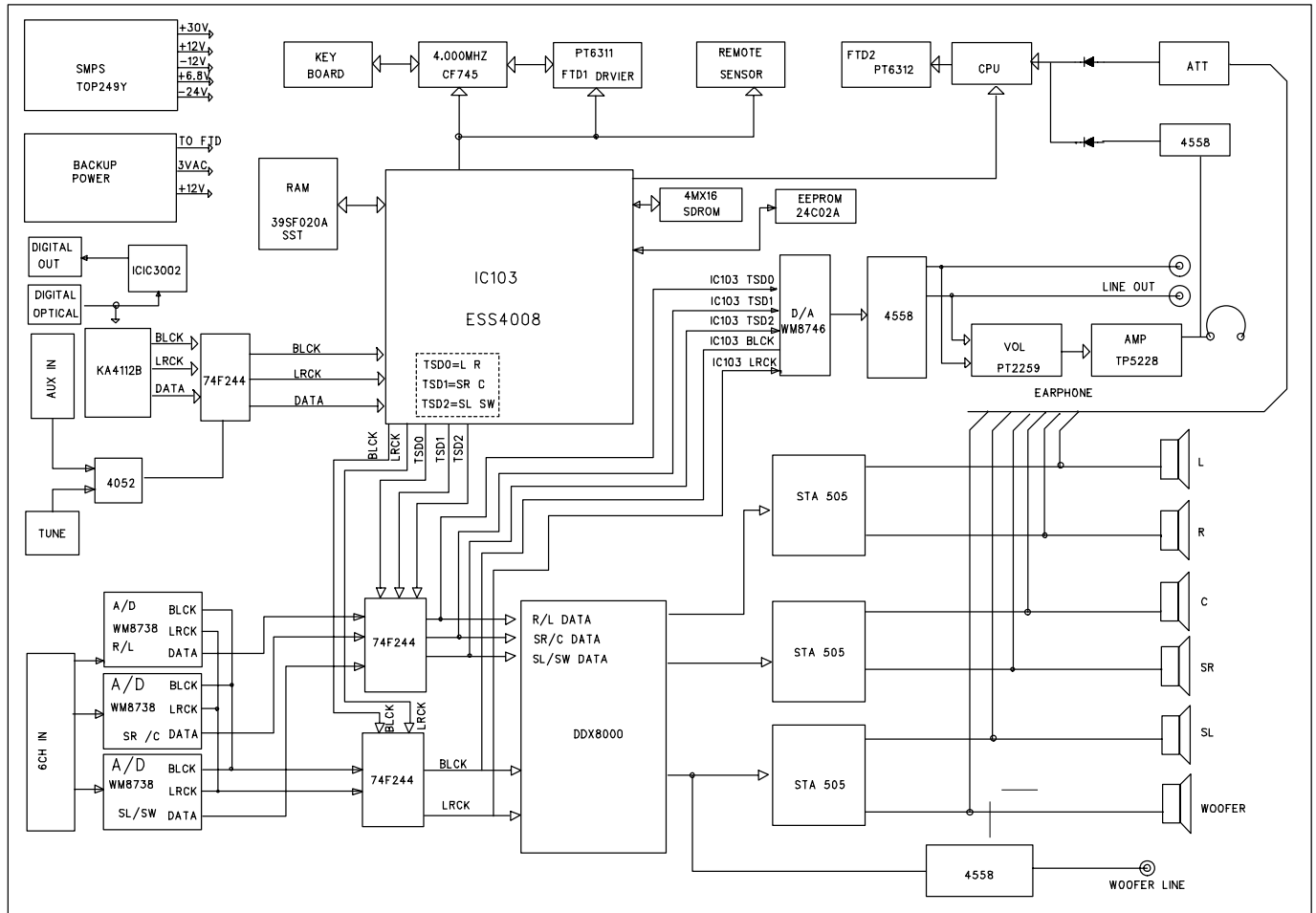



# KEY / POWER SW BOARD

## TABLE OF CONTENTS

- IC Internal Block Diagram .....5-1
- Circuit Diagram.....5-2
- PCB Layout Top & Bottom View.....5-3
- Electrical Parts List .....5-4

### CF745 INTERNAL BLOCK DIAGRAM

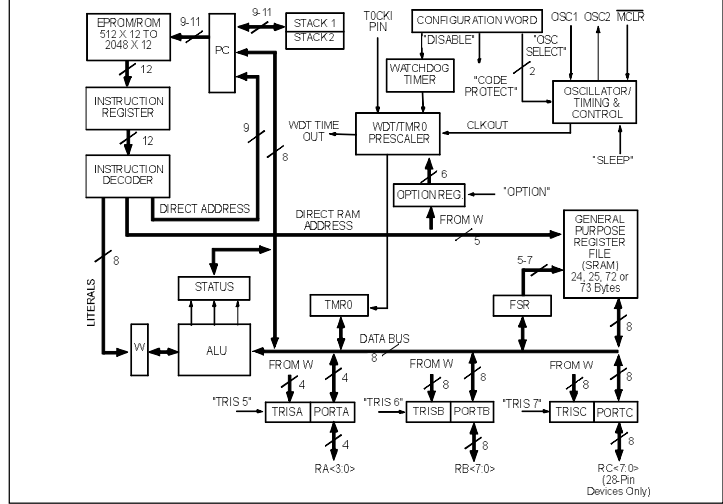

### PT6311 INTERNAL BLOCK DIAGRAM

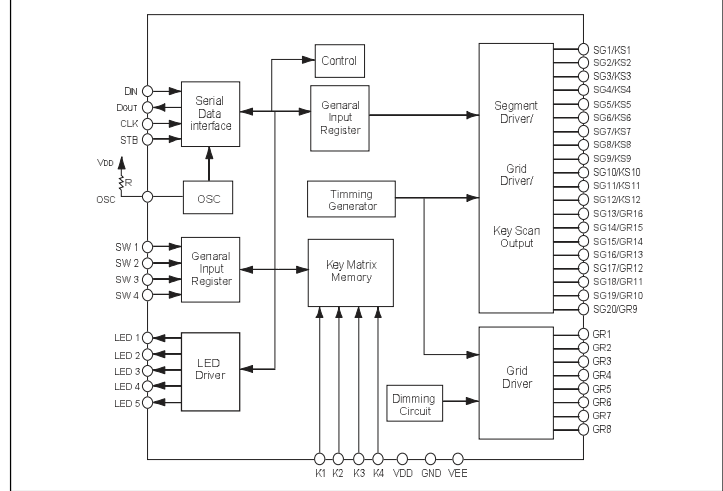

CIRCUIT DIAGRAM

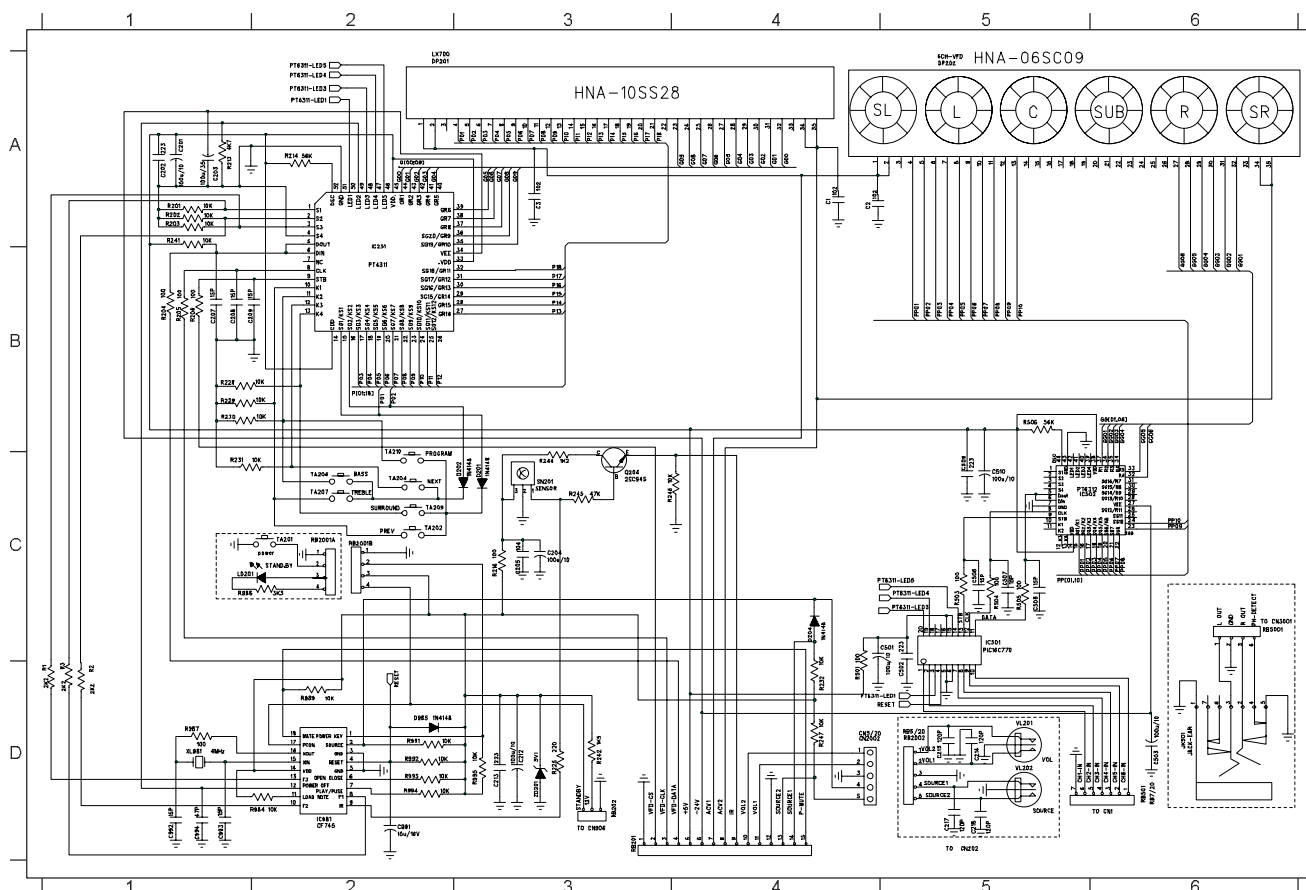

C1	A4	R247	D4
C2	A4	R255	D3
C3	A3	R501	D4
C201	A1	R503	C5
C202	A1	R504	C5
C203	A1	R505	C5
C204	C3	R506	B5
C205	C3	R984	D2
C207	B1	R987	C1
C208	B1	R988	C1
C209	B1	R989	D2
C212	D3	R991	D2
C213	D3	R992	D2
C214	D5	R993	D2
C215	D5	R994	D2
C217	D5	R995	D3
C218	D5	RB201	D3
C501	C5	RB202	D3
C502	D5	RB501	D6
C503	D6	RB2001A	C2
C506	C5	RB2001B	C2
C507	C5	RB2002	C2
C508	C5	RB5001	C6
C509	C5	SN201	C3
C510	C5	TA201	C2
C991	D2	TA202	C2
C992	D1	TA204	C2
C993	D1	TA206	C2
C994	D1	TA207	C2
CN2002	D4	TA209	C2
D201	C3	TA210	C2
D202	C3	VL201	D5
D204	C4	VL202	D5
D985	D2	XL981	D1
DP201	A2	ZD201	D3
DP202	A5		
IC251	A2		
IC501	C5		
IC502	C5		
IC981	D2		
IC982	D6		
LD201	C1		
Q204	C3		
R1	D1		
R2	D1		
R3	D1		
R201	A1		
R202	A1		
R203	A1		
R204	B1		
R205	B1		
R206	B1		
R213	A1		
R214	A2		
R216	C3		
R228	B1		
R229	B1		
R230	B1		
R231	C1		
R232	D4		
R241	A1		
R242	D3		
R244	C3		
R245	C3		
R246	C3		

PCB LAYOUT VIEW

C201	B3	CN2002	B3	LD201	A1	RB201	B3	TA204	B6
C203	B2	D201	A4	R204	A4	RB202	B1	TA206	B6
C204	B5	D202	A4	R205	A4	RB501	B1	TA207	B6
C212	B5	D204	B2	R206	A4	RB2001A	A1	TA209	A3
C501	A1	D965	A1	R225	B4	RB2001B	A1	TA210	B5
C503	B4	DP201	A5	R241	A3	SN201	A5	XL981	A2
C510	B3	DP202	A3	R242	B1	TA201	B1	ZD201	A1
C991	B2	IC981	B2	R247	B3	TA202	B6		

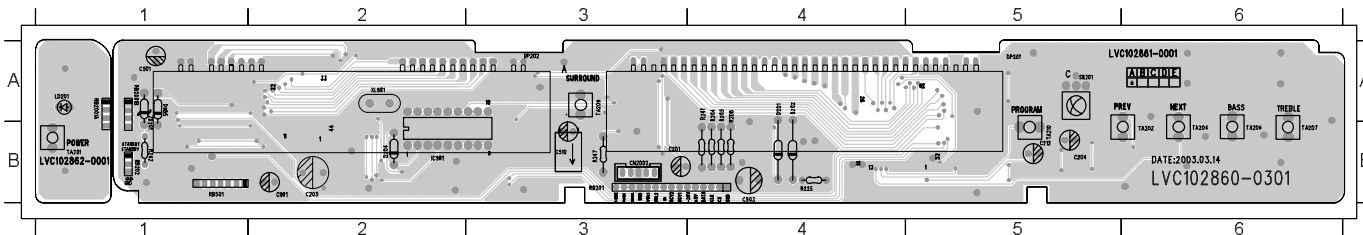

C1	A4	C502	B6	IC501	A6	R213	A5	R245	B2	R987	A5
C2	A4	C506	B5	IC502	A5	R214	B2	R246	A2	R988	B6
C3	A2	C507	B5	Q204	B2	R216	A2	R501	A6	R989	A5
C202	A5	C508	B5	R1	A4	R228	A3	R502	A1	R991	B5
C205	A2	C509	A5	R2	B4	R229	A2	R503	B5	R992	B5
C207	A3	C992	B5	R3	B4	R230	A2	R504	B5	R993	B4
C208	A3	C993	A5	R201	B4	R231	A2	R505	B5	R994	B6
C209	A3	C994	A5	R202	B4	R232	B5	R506	B5	R995	B5
C213	B5	IC251	B3	R203	A4	R244	B2	R984	B4		

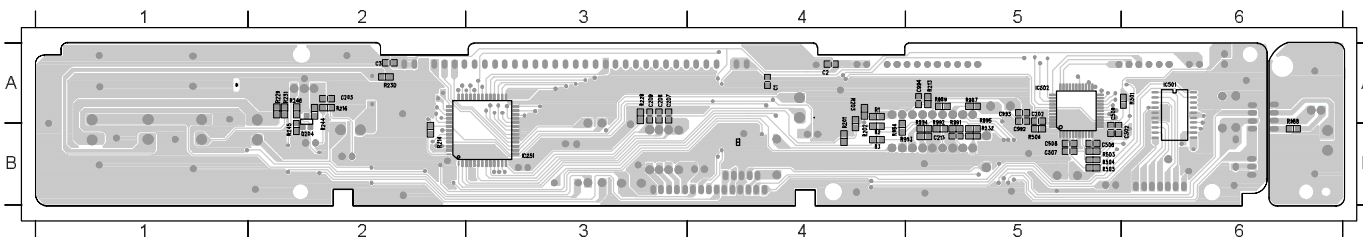

**ELECTRICAL PARTSLIST - KEY + POWER BOARD****- MISCELLANEOUS -**

CN2002	9965 000 15895	CONNECTOR 5P
DP201	9965 000 17398	VFD HNA-10SS28
DP202	9965 000 17399	VFD HNA-06SC09
LD201	9965 000 17400	LED
RB2001	9965 000 17401	CONWIRE 4P 40MM
RB201	9965 000 17402	CONWIRE 15P
RB202	9965 000 17403	CONWIRE 3P 260MM
RB501	9965 000 17404	CONWIRE 7P 220MM
SN201	9965 000 13071	IRT SENSOR
TA201	4822 276 13648	TACT SWITCH
TA202	4822 276 13648	TACT SWITCH
TA204	4822 276 13648	TACT SWITCH
TA206	4822 276 13648	TACT SWITCH
TA207	4822 276 13648	TACT SWITCH
TA209	4822 276 13648	TACT SWITCH
TA210	4822 276 13648	TACT SWITCH

**- COILS & FILTERS -**

XL981	9965 000 17405	CRYSTAL 4.00000MHZ
-------	----------------	--------------------

**- DIODES -**

D201	4822 130 30621	1N4148
D202	4822 130 30621	1N4148
D204	4822 130 30621	1N4148
D985	4822 130 30621	1N4148
ZD201	4822 130 34233	BZX79-B5V1

**- IC & TRANSISTORS -**

IC251	9965 000 12550	PT6311(PTC)
IC501	9965 000 17445	IC PIC16C770
IC502	9965 000 17446	IC PT6312 44 PIN
IC981	9965 000 17447	IC S-CPU EM78P158ELP
Q204	9965 000 17448	XISTR NPN SMT (2SC945)

**Note:** Only these parts mentioned in the list are normal service parts.

---

# **SOURCE + PHONE / 6 CH IN BOARD**

---

CIRCUIT DIAGRAM - SOURCE + PHONE PCB

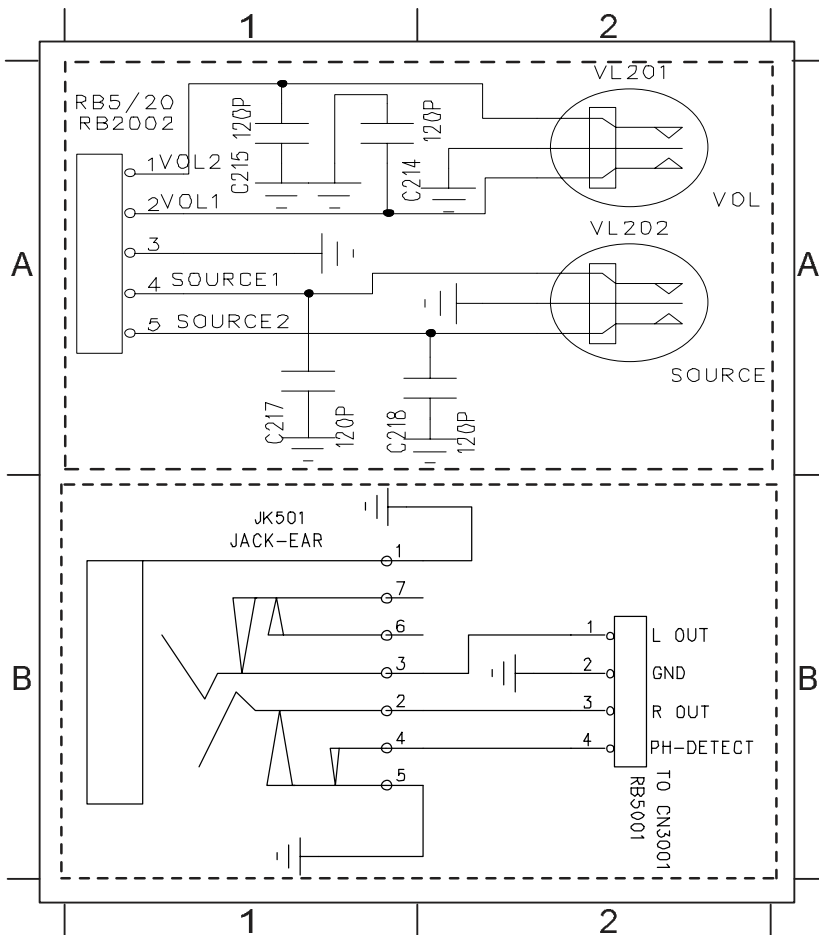

C214	A1
C215	A1
C217	A1
C218	A1
JK501	B1
RB2002	A1
RB5001	B2
VL201	A2
VL202	A2



**CIRCUIT DIAGRAM - 6 CH IN PCB**

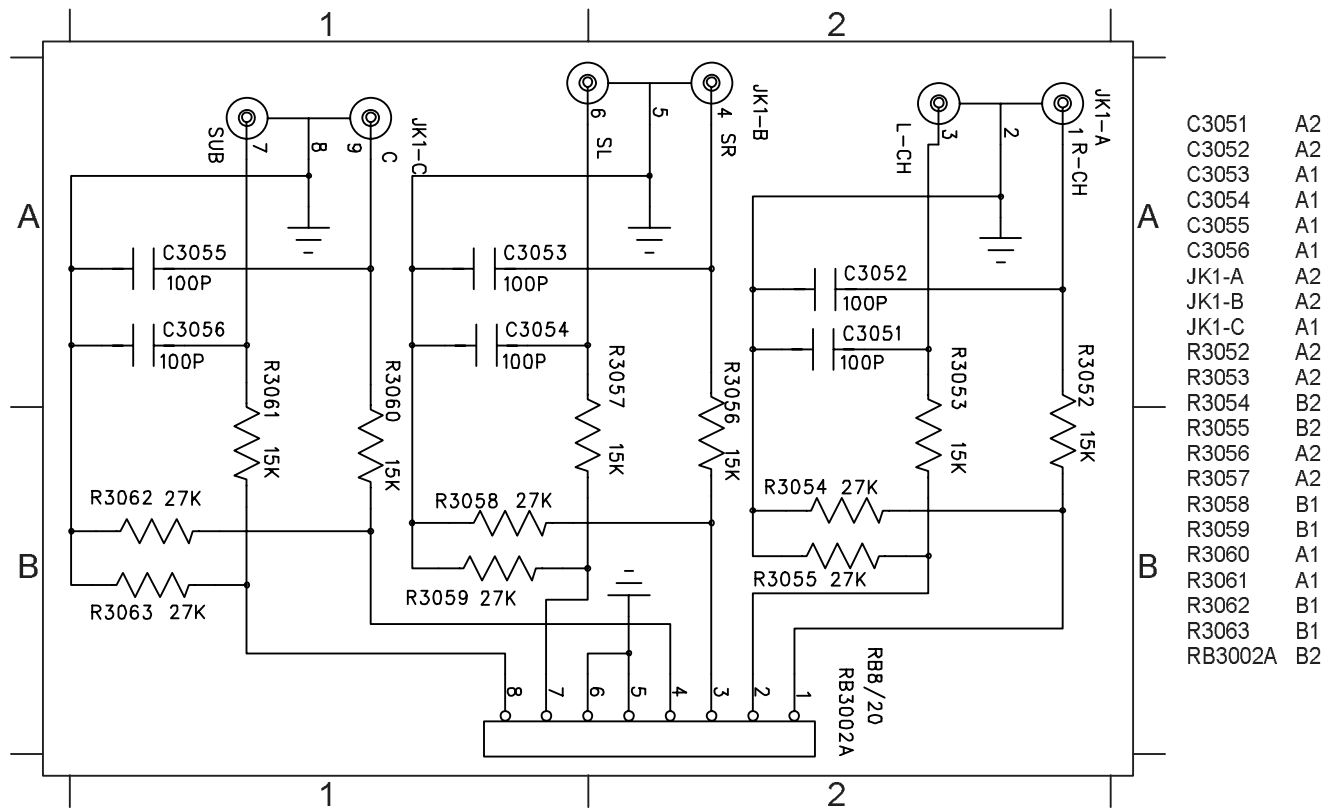

**PCB LAYOUT - 6 CH IN PCB**

**ELECTRICAL PARTSLIST - KEY + POWER BOARD**

---

**- MISCELLANEOUS -**

---

JK501	9965 000 12505	CINCH SOCKET 6P WHITE/RED
RB2002	9965 000 17449	CON/WIRE 5P 230MM
RB5001	9965 000 17450	CON/WIRE 4P 90MM
VL201	△ 9965 000 17451	ROTARY L20XF7MM P2.5MM
VL202	△ 9965 000 17451	ROTARY L20XF7MM P2.5MM

**ELECTRICAL PARTSLIST - KEY + POWER BOARD**

---

**- MISCELLANEOUS -**

---

JK1	9965 000 17452	6P WHTX2-BLU/REDX2-BLK
RB3002	9965 000 17453	8P 250MM 2547#26X2P

# POWER BOARD

**TABLE OF CONTENTS**

Internal IC Diagram.....7-1  
 Circuit Diagram.....7-2  
 PCB Layout.....7-3  
 Electrical Parts List.....7-4

**TL431 EQUIVALENT SCHEMATIC**

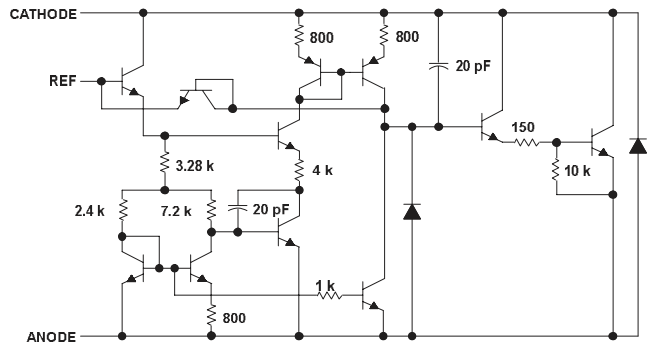

**TOP249 BLOCK DIAGRAM**

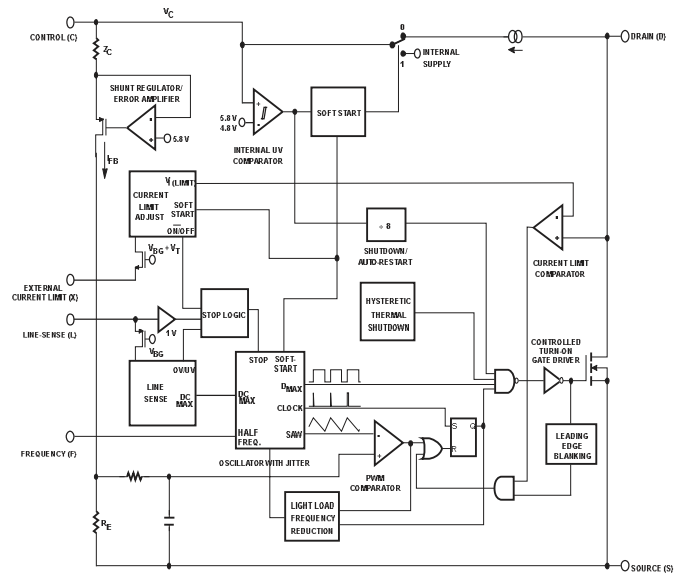

CIRCUIT DIAGRAM

BR901 A3	C908 A4	C919 C5	C933 A6	C949 A6	C966 A5	CN907 B3	D907 A5	L902 B6	R901 A3	R919 B5	R931 A5	R948 D3	XR8906D6	ZD901 A4
C901 A2	C909 A4	C920 C5	C938 B5	C950 A6	C967 B5	CN908 B3	D908 B5	L903 A6	R902 B3	R920 B5	R932 A6	R949 C4	RL901 C3	ZD902 C4
C902 A3	C910 B4	C925 B5	C939 B5	C951 A6	C968 A3	D901 B4	D909 B5	Q903 C5	R903 A3	R921 B5	R941 D3	R950 C5	RT901 A1	ZD903 A6
C903 B3	C911 B4	C926 B6	C940 B6	C952 A6	C969 B4	D902 B4	D910 B5	Q904 A6	R904 B4	R922 B5	R942 D3	R951 C4	SN901 B4	ZD946 D4
C904 B3	C912 B4	C923 A5	C941 B6	C953 C3	C970 B6	D903 C3	F901 A2	Q910 C3	R905 A4	R923 C5	R943 D4	R952 A5	T901 A2	
C905 B3	C913 B4	C930 A5	C945 A5	C963 A4	C971 B6	D904 C3	IC903 B3	Q912 C3	R906 A4	R924 C5	R945 D4	R953 B2	T902 C2	
C906 B3	C914 C3	C931 B6	C947 A5	C964 A4	C972 B5	D905 A5	IC904 C5	Q913 D4	R907 B4	R925 C5	R946 D3	R954 B6	T903 B4	
C907 A4	C915 B4	C932 A6	C948 A5	C965 A5	CN902 B2	D906 B5	L901 A6	R1 B5	R908 B4	R928 B6	R947 D3	R947 D3	ZD1 B6	

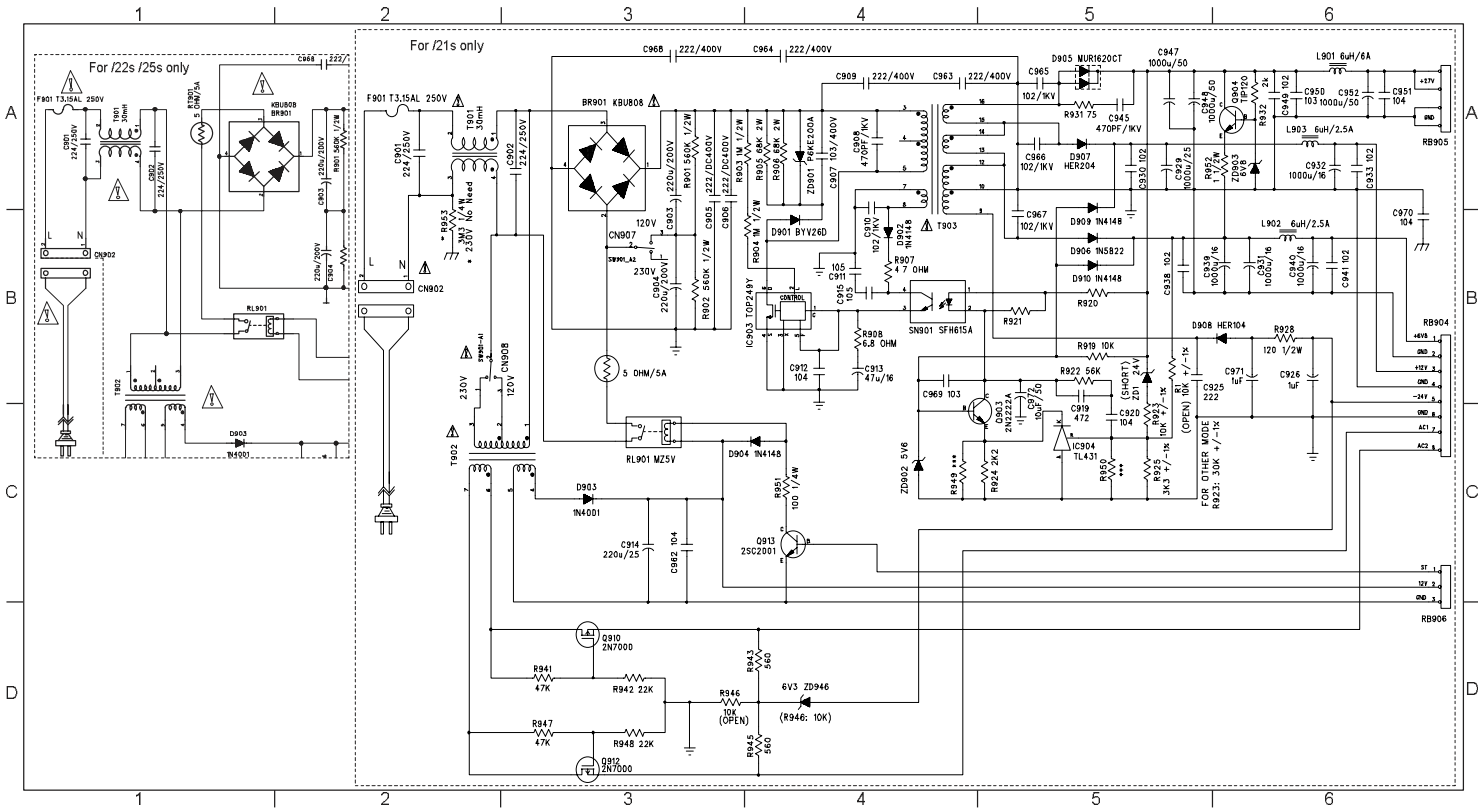

POWER PCB LAYOUT

BR901	B2	C908	A2	C919	B3	C933	B4	C949	A4	C966	A3	CN907	A2	D907	B3	JW904	C3	C5038	C5	P904	C2	R1	C4	R908	B3	R928	C3	R947	C3	RB905	B4	RB905	B4
C901	A1	C909	A3	C920	C3	C938	B4	C950	A4	C967	A4	CN908	C1	D908	B3	JW905	C3	L901	A4	P905	C3	R901	B2	R919	C3	R931	A4	R948	C3	RB906	C4	ZD901	A2
C902	B1	C910	B3	C925	B3	C939	B4	C951	B4	C968	B3	D901	A2	D909	B3	JW906	C3	L902	B4	P906	C4	R902	B2	R920	C3	R932	C4	R949	B3	RL901	B2	ZD902	C3
C903	A2	C911	C3	C926	C3	C940	B4	C952	B4	C969	B3	D902	B2	D910	B3	JW907	C1	L903	B4	Q903	B3	R903	A2	R921	B3	R941	C3	R950	C3	RT901	B1	ZD903	C4
C904	B2	C912	B3	C929	C4	C941	B4	C962	C2	C970	A3	D903	C2	F901	A1	JW908	C4	L905	A4	Q904	C4	R904	B2	R922	B3	R942	C3	R951	C3	SN901	B3	ZD946	C3
C905	B2	C913	C3	C930	C3	C945	A4	C963	A3	C971	B3	D904	C2	IC903	B2	JW909	C4	P901	B1	Q910	C3	R905	A2	R923	C3	R943	C3	R952	C4	T901	B1		
C906	B2	C914	C2	C931	B4	C947	A4	C964	B3	C972	B3	D905	A4	IC904	B3	JW910	B3	P902	B2	Q912	C3	R906	A2	R924	B3	R945	C3	R953	A1	T902	C1		
C907	A2	C915	C3	C932	C4	C948	A4	C965	A3	CN902	A1	D906	B4	JW903	C3	JW911	C3	P903	B1	Q913	C4	R907	B3	R925	C3	R946	C3	RB904	B4	T903	A3		

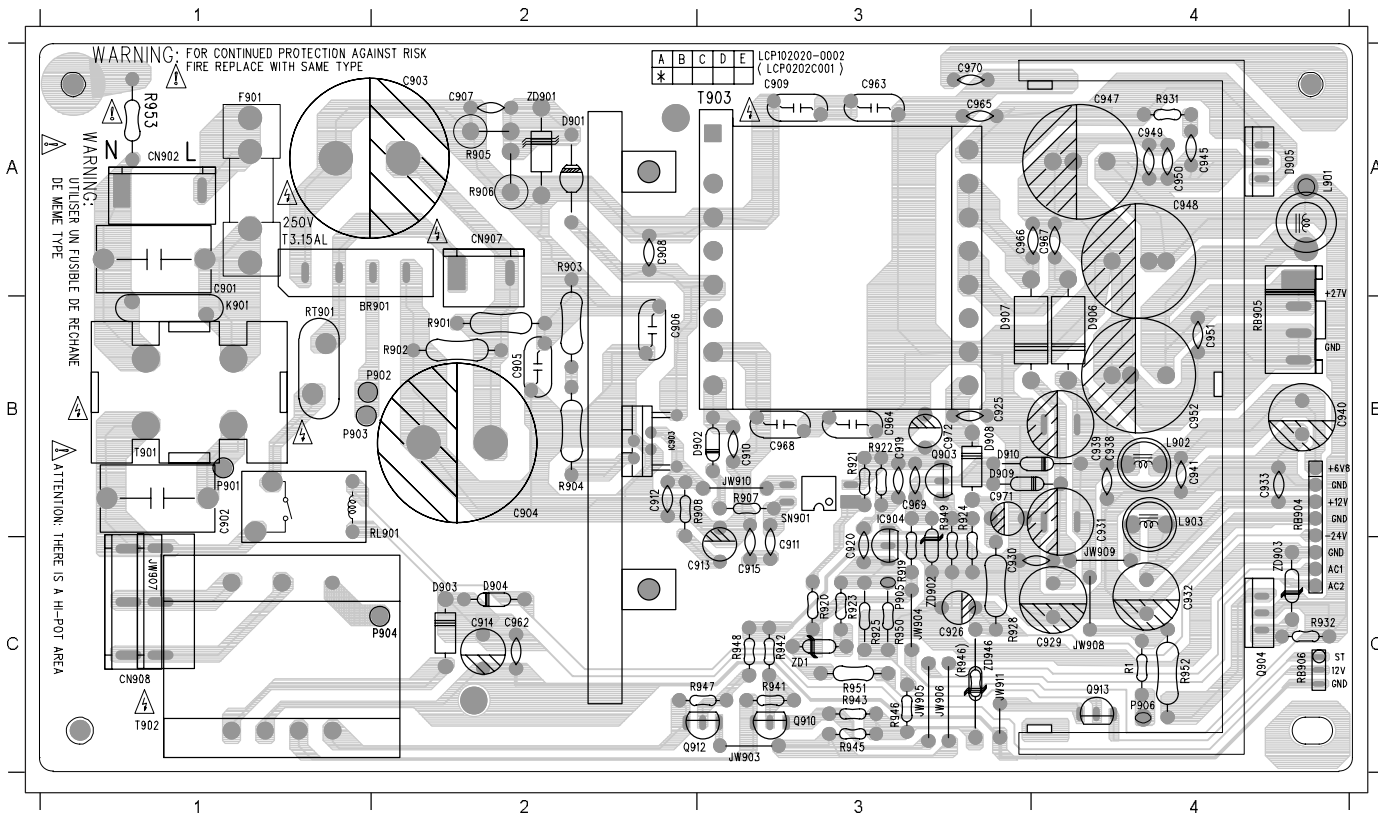

**ELECTRICAL PARTSLIST - POWER BOARD****- MISCELLANEOUS -**

CN902	9965 000 15936	CONNECTOR 4P
CN907	9965 000 17458	CONNECTOR 3P /21S
CN908	9965 000 17459	CONNECTOR 5P /21S
F901	△ 9965 000 17388	FUSE 3.15A 250V SLOW
RB904	9965 000 17389	8P 260MM 2468#26
RB905	9965 000 17390	4P 260MM RDX2-WTX2
RB906	0000 000 00000	3P 220mm
RL901	△ 9965 000 15937	RELAY
T902	△ 9965 000 17391	PWR TRANS EI-35 110~230V
T903	△ 9965 000 17392	PWR TRANS EI-42
SN901	9965 000 15769	PHOTO COUPLER

**- IC & TRANSISTORS -**

IC904	9965 000 17387	IC TL431
Q903	9965 000 17396	PN2222A FAIRCHILD
Q904	9965 000 17397	XISTR NPN TIP120
Q910	9965 000 16497	2N7000TA 60V/0.2A
Q912	9965 000 16497	2N7000TA 60V/0.2A
Q913	4822 130 41651	2SC2001L

**- RESISTORS -**

R905	9965 000 17393	68K 2W 5% W/KINK
R906	9965 000 17393	68K 2W 5% W/KINK
RT901	9965 000 17394	5R 5A

**- COILS & FILTERS -**

L901	9965 000 16693	6UH 10.5TS 6A
L902	9965 000 16694	6UH 13.5TS 2UEW
L903	9965 000 16694	6UH 13.5TS 2UEW
T901	9965 000 17395	1.7A L1:86TS L2:86TS

**- DIODES -**

BR901	9965 000 14146	ZENER 6.4-6.7V 0.5W
D901	4822 130 11044	BYV26D
D902	4822 130 30621	1N4148
D903	4822 130 31438	1N4001G
D904	4822 130 30621	1N4148
D905	9965 000 14186	MUR1620CT 8A 200V
D906	5322 130 32677	1N5822
D907	9965 000 14187	HER204 2A/300V 50NS
D908	9965 000 14188	HER104 1A/300V 50NS
D909	4822 130 30621	1N4148
D910	4822 130 30621	1N4148
ZD1	9965 000 17373	23.6-24.7V 0.5W
ZD901	9965 000 14209	P6KE200A
ZD902	9965 000 15944	DIODE ZENR 5.6-5.9V 0.5W
ZD903	4822 130 80272	MTZJ7.5C
ZD946	4822 130 34167	BZX79-B6V2

Note: Only these parts mentioned in the list are normal service parts.

**- IC & TRANSISTORS -**

IC903	9965 000 14189	TOP249Y 250W
-------	----------------	--------------

# MAIN BOARD

## TABLE OF CONTENTS

- Internal IC Diagram .....8-1
- Circuit Diagram (Top Left) ..... 8-6
- Circuit Diagram (Top Right).....8-7
- Circuit Diagram (Bottom Left) .....8-8
- Circuit Diagram ( Bottom Right) .....8-9
- PCB Layout(Component View) .....8-10
- PCB Layout(Copperside View).....8-12
- Electrical Parts list .....8-14

LC72131 INTERNAL IC DIAGRAM

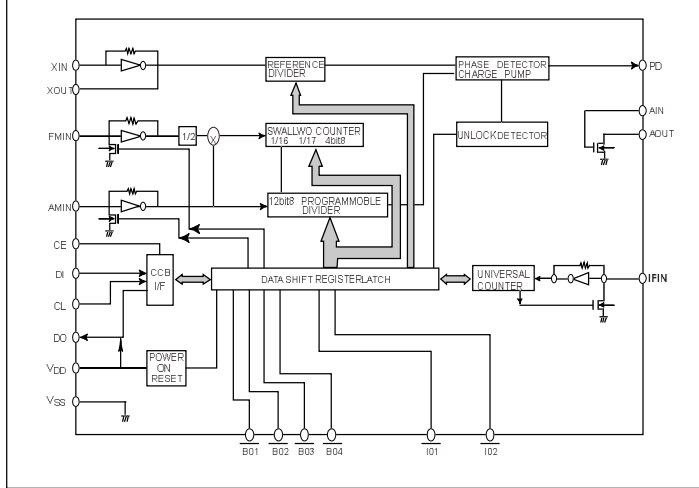

ST505 INTERNAL IC DIAGRAM

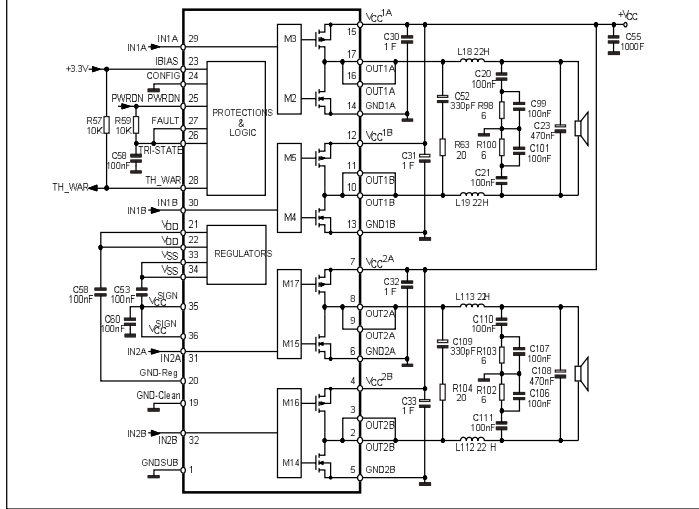

LA1837 INTERNAL IC DIAGRAM

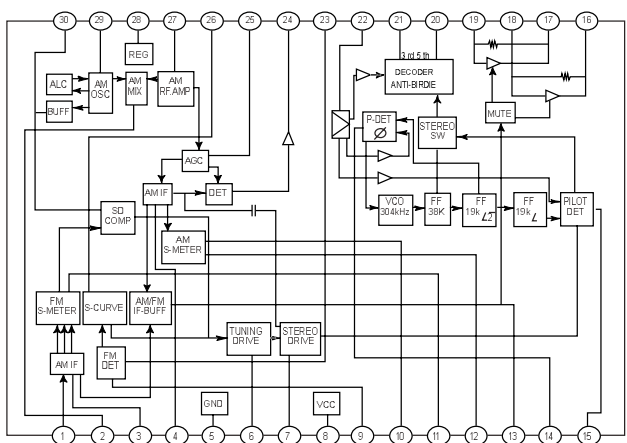

ESS4008 INTERNAL IC DIAGRAM

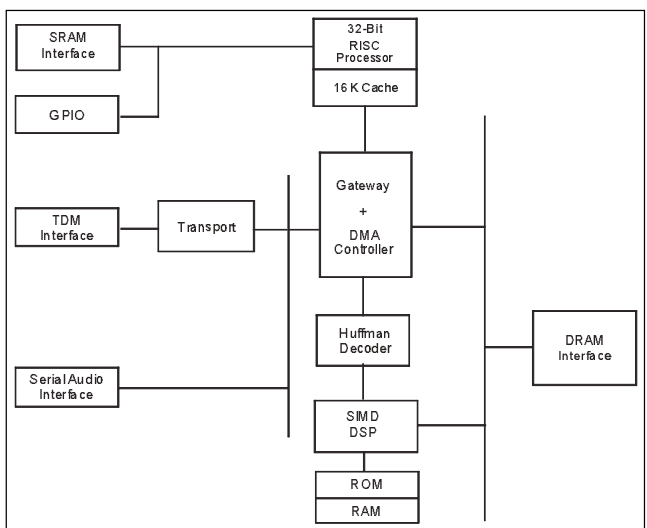

SYNCHRONOUS DRAM  
1MX16Y3VTW

PIN ASSIGNMENT (Top View)  
50 - Pin T SOP

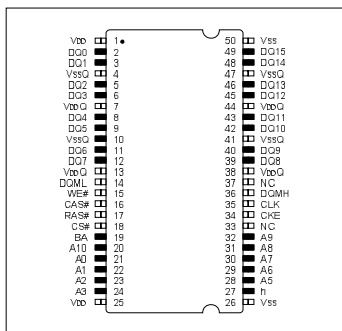

Note: The # symbol indicates signal is active LOW.

1 Meg x 16	
Configuration	512x16x2 banks
Refresh Count	2K or 4K
Row Addressing	2K (A0-A10)
Bank Addressing	2 (BA)
Column Addressing	256 (A0-A7)

FUNCTIONAL BLOCK DIAGRAM  
1 Meg x 16 SDRAM

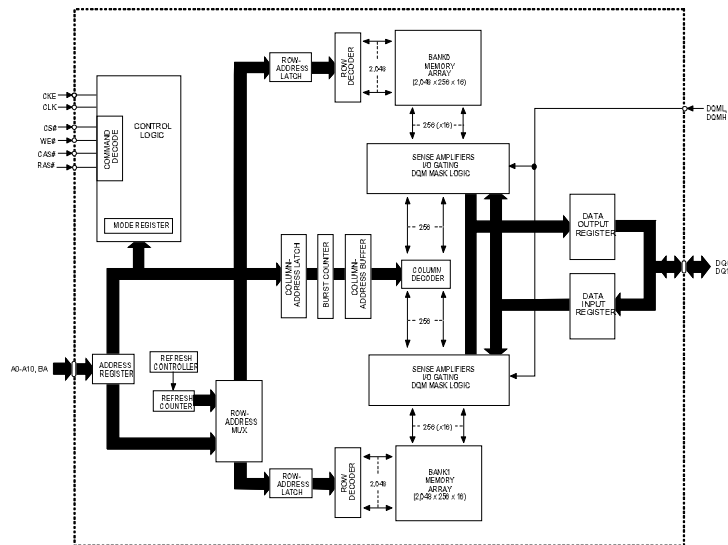



DIGITAL AUDIO PROCESSOR  
STA308

BLOCK DIAGRAM

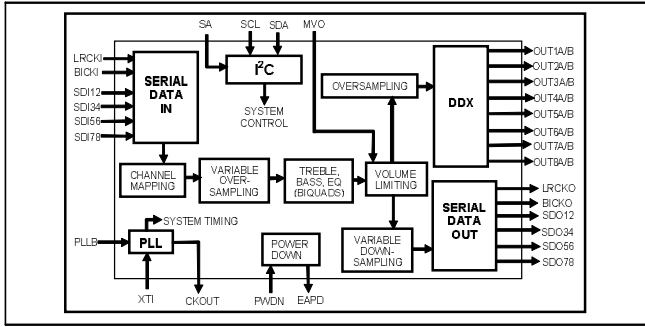

DIGITAL AUDIO PROCESSOR  
STA308

PIN CONNECTION (Top view)

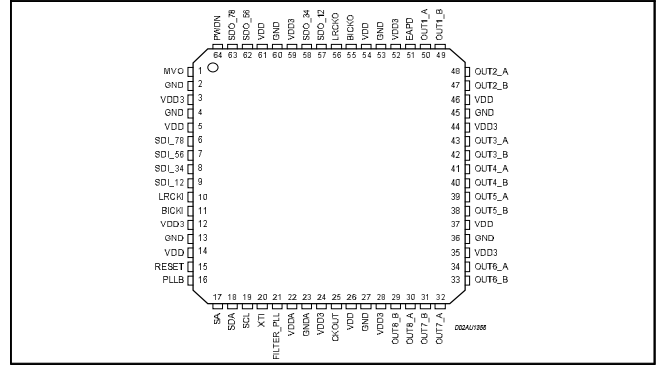

SIGNAL FLOW DIAGRAM

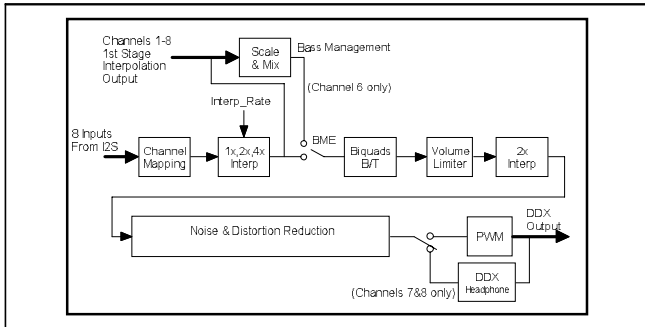

PIN FUNCTION

PIN	NAME	TYPE	DESCRIPTION	PAD TYPE
1	MVO	I	Master Volume Override	CMOS Input Buffer with Pull-Down
3, 12, 24, 28, 35, 44, 52, 59	VDD3		3.3V Digital Supply	3.3V Digital Power Supply Voltage (pad ring)
2, 4, 13, 27, 36, 45, 53, 60	GND		Digital Ground	Digital Ground
5, 14, 26, 37, 46, 54, 61	VDD		2.5V Digital Supply	2.5V Digital Power Supply Voltage (core + ring)
6	SDI_7/8	I	Input I2S Serial Data Channels 7 & 8	5V Tolerant TTL Input Buffer
7	SDI_5/6	I	Input I2S Serial Data Channels 5 & 6	5V Tolerant TTL Input Buffer
8	SDI_3/4	I	Input I2S Serial Data Channels 3 & 4	5V Tolerant TTL Input Buffer
9	SDI_1/2	I	Input I2S Serial Data Channels 1 & 2	5V Tolerant TTL Input Buffer
10	LRCKI	I	Inputs I2C Left/Right Clock	5V Tolerant TTL Input Buffer
11	BICKI	I	Inputs I2C Serial Clock	5V Tolerant TTL Input Buffer
15	RESET	I	Global Reset	5V Tolerant TTL Schmitt Trigger Input Buffer
16	PLLB	I	PLL Bypass	CMOS Input Buffer with Pull-Down
17	SA	I	Select Address (I2C)	CMOS Input Buffer with Pull-Down
18	SDA	I/O	I2C Serial Data	Bidirectional Buffer; 5V Tolerant TTL Schmitt Trigger Input; 3.3V Capable 2 mA Slew-rate control Output;
19	SCL	I	I2C Serial Clock	5V Tolerant TTL Schmitt Trigger Input Buffer

## PIN FUNCTION (continued)

PIN	NAME	TYPE	DESCRIPTION	PAD TYPE
20	XTI	I	Crystal Oscillator Input (Clock Input)	3.3V Tolerant TTL Schmitt Trigger Input Buffer
21	FILTER_PLL		PLL Filter	Analog Pad
22	VDDA		PLL 2.5V Supply	2.5V Analog Power Supply Voltage
23	GNDA		PLL Ground	Analog Ground
25	CKOUT	O	Clock Output	3.3V Capable TTL Instate 4mA Output Buffer
29	OUT8_B	O	PWM Channel 8 Output B	3.3V Capable TTL 2mA Output Buffer
30	OUT8_A	O	PWM Channel 8 Output A	3.3V Capable TTL 2mA Output Buffer
31	OUT7_B	O	PWM Channel 7 Output B	3.3V Capable TTL 2mA Output Buffer
32	OUT7_A	O	PWM Channel 7 Output A	3.3V Capable TTL 2mA Output Buffer
33	OUT6_B	O	PWM Channel 6 Output B	3.3V Capable TTL 2mA Output Buffer
34	OUT6_A	O	PWM Channel 6 Output A	3.3V Capable TTL 2mA Output Buffer
38	OUT5_B	O	PWM Channel 5 Output B	3.3V Capable TTL 2mA Output Buffer
39	OUT5_A	O	PWM Channel 5 Output A	3.3V Capable TTL 2mA Output Buffer
40	OUT4_B	O	PWM Channel 4 Output B	3.3V Capable TTL 2mA Output Buffer
41	OUT4_A	O	PWM Channel 4 Output A	3.3V Capable TTL 2mA Output Buffer
42	OUT3_B	O	PWM Channel 3 Output B	3.3V Capable TTL 2mA Output Buffer
43	OUT3_A	O	PWM Channel 3 Output A	3.3V Capable TTL 2mA Output Buffer
47	OUT2_B	O	PWM Channel 2 Output B	3.3V Capable TTL 2mA Output Buffer
48	OUT2_A	O	PWM Channel 2 Output A	3.3V Capable TTL 2mA Output Buffer
49	OUT1_B	O	PWM Channel 1 Output B	3.3V Capable TTL 2mA Output Buffer
50	OUT1_A	O	PWM Channel 1 Output A	3.3V Capable TTL 2mA Output Buffer
51	EAPD	O	External Amplifier Power Down	3.3V Capable TTL 2mA Output Buffer
55	BICKO	O	Output I2S Serial Clock	3.3V Capable TTL 2mA Output Buffer
56	LRCKO	O	Output I2S Left/Right Clock	3.3V Capable TTL 2mA Output Buffer
57	SDO_12	O	Output I2S Serial Data Channels 1 & 2	3.3V Capable TTL 2mA Output Buffer
58	SDO_34	O	Output I2S Serial Data Channels 3 & 4	3.3V Capable TTL 2mA Output Buffer
62	SDO_56	O	Output I2S Serial Data Channels 5 & 6	3.3V Capable TTL 2mA Output Buffer
63	SDO_78	O	Output I2S Serial Data Channels 7 & 8	3.3V Capable TTL 2mA Output Buffer
64	PWDN	I	Device Powerdown	5V Tolerant TTL Schmitt Trigger Input Buffer

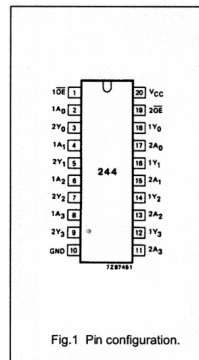

Fig.1 Pin configuration.

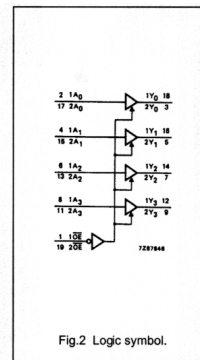

Fig.2 Logic symbol.

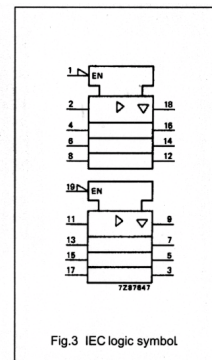

Fig.3 IEC logic symbol

## PIN DESCRIPTION

PIN NO.	SYMBOL	NAME AND FUNCTION
1	1OE	output enable input (active LOW)
2, 4, 6, 8	1A <sub>0</sub> to 1A <sub>3</sub>	data inputs
3, 5, 7, 9	2Y <sub>0</sub> to 2Y <sub>3</sub>	bus outputs
10	GND	ground (0 V)
17, 15, 13, 11	2A <sub>0</sub> to 2A <sub>3</sub>	data inputs
18, 16, 14, 12	1Y <sub>0</sub> to 1Y <sub>3</sub>	bus outputs
19	2OE	output enable input (active LOW)
20	V <sub>cc</sub>	positive supply voltage

OCTAL BUFFER / LINE DRIVER  
74HCT244

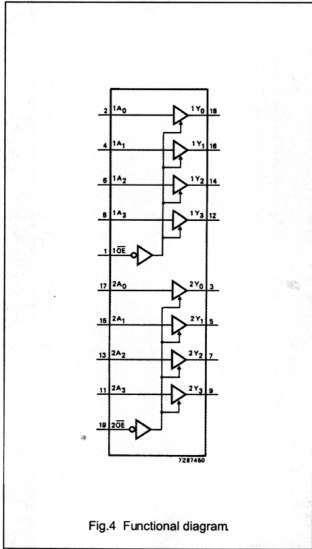

Fig.4 Functional diagram

FUNCTION TABLE

INPUTS		OUTPUT
nOE	nAn	nYn
L	L	L
L	H	H
H	X	Z

Note

- 1. H = HIGH voltage level
- L = LOW voltage level
- X = don't care
- Z = high impedance OFF-state

MULTI-PURPOSE FLASH  
SST39SF020A

FUNCTIONAL BLOCK DIAGRAM

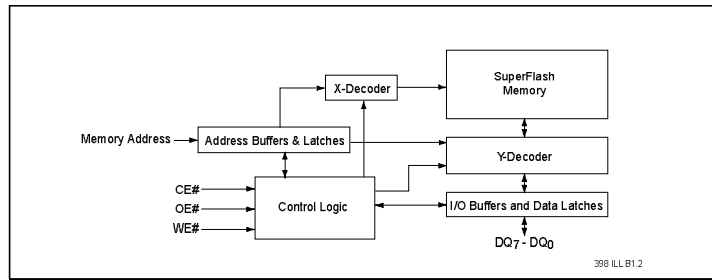

398 ILL B1.2

PIN ASSIGNMENTS FOR 32-PIN PDIP

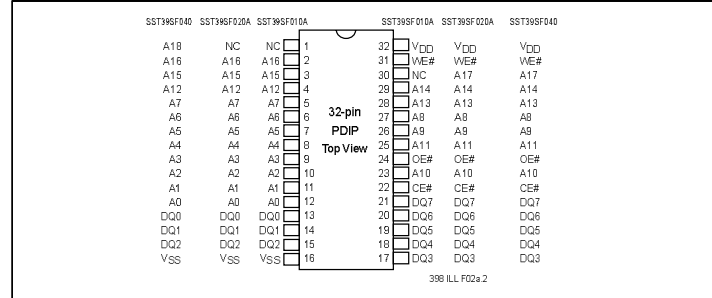

398 ILL F02x2

PIN DESCRIPTION

Symbol	Pin Name	Functions
$A_{MS} \sim A_0$	Address Inputs	To provide memory addresses. During Sector-Erase $A_{MS} \sim A_{12}$ address lines will select the sector.
$DQ_7 \sim DQ_0$	Data Input/output	To output data during Read cycles and receive input data during Write cycles. Data is internally latched during a Write cycle. The outputs are in tri-state when OE# or CE# is high.
CE#	Chip Enable	To activate the device when CE# is low.
OE#	Output Enable	To gate the data output buffers.
WE#	Write Enable	To control the Write operations.
V <sub>DD</sub>	Power Supply	To provide 5.0V supply (4.5-5.5V)
V <sub>SS</sub>	Ground	
NC	No Connection	Unconnected pins.

1.  $A_{MS}$  = Most significant address  
 $A_{MS} = A_{16}$  for SST39SF010A,  $A_{17}$  for SST39SF020A, and  $A_{18}$  for SST39SF040

CIRCUIT DIAGRAM (TOP LEFT)

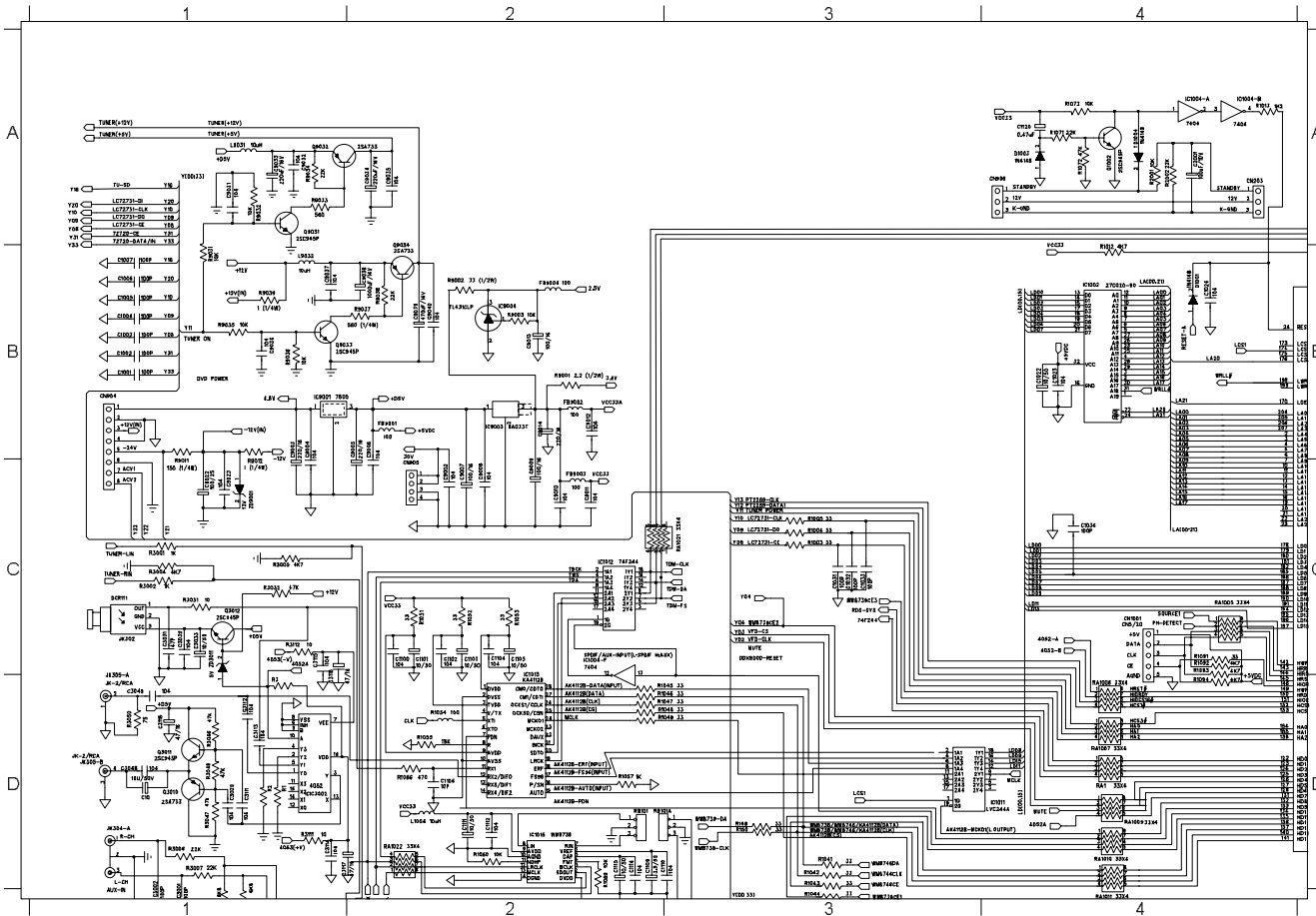

- C10
- C1001
- C1002
- C1003
- C1004
- C1005
- C1006
- C1007
- C1008
- C1009
- C1010
- C1011
- C1012
- C1013
- C1014
- C1015
- C1016
- C1017
- C1018
- C1019
- C1020
- C1021
- C1022
- C1023
- C1024
- C1025
- C1026
- C1027
- C1028
- C1029
- C1030
- C1031
- C1032
- C1033
- C1034
- C1035
- C1036
- C1037
- C1038
- C1039
- C1040
- C1041
- C1042
- C1043
- C1044
- C1045
- C1046
- C1047
- C1048
- C1049
- C1050
- C1051
- C1052
- C1053
- C1054
- C1055
- C1056
- C1057
- C1058
- C1059
- C1060
- C1061
- C1062
- C1063
- C1064
- C1065
- C1066
- C1067
- C1068
- C1069
- C1070
- C1071
- C1072
- C1073
- C1074
- C1075
- C1076
- C1077
- C1078
- C1079
- C1080
- C1081
- C1082
- C1083
- C1084
- C1085
- C1086
- C1087
- C1088
- C1089
- C1090
- C1091
- C1092
- C1093
- C1094
- C1095
- C1096
- C1097
- C1098
- C1099
- C1100
- C1101
- C1102
- C1103
- C1104
- C1105
- C1106
- C1107
- C1108
- C1109
- C1110
- C1111
- C1112
- C1113
- C1114
- C1115
- C1116
- C1117
- C1118
- C1119
- C1120
- C1121
- C1122
- C1123
- C1124
- C1125
- C1126
- C1127
- C1128
- C1129
- C1130
- C1131
- C1132
- C1133
- C1134
- C1135
- C1136
- C1137
- C1138
- C1139
- C1140
- C1141
- C1142
- C1143
- C1144
- C1145
- C1146
- C1147
- C1148
- C1149
- C1150
- C1151
- C1152
- C1153
- C1154
- C1155
- C1156
- C1157
- C1158
- C1159
- C1160
- C1161
- C1162
- C1163
- C1164
- C1165
- C1166
- C1167
- C1168
- C1169
- C1170
- C1171
- C1172
- C1173
- C1174
- C1175
- C1176
- C1177
- C1178
- C1179
- C1180
- C1181
- C1182
- C1183
- C1184
- C1185
- C1186
- C1187
- C1188
- C1189
- C1190
- C1191
- C1192
- C1193
- C1194
- C1195
- C1196
- C1197
- C1198
- C1199
- C1200
- C1201
- C1202
- C1203
- C1204
- C1205
- C1206
- C1207
- C1208
- C1209
- C1210
- C1211
- C1212
- C1213
- C1214
- C1215
- C1216
- C1217
- C1218
- C1219
- C1220
- C1221
- C1222
- C1223
- C1224
- C1225
- C1226
- C1227
- C1228
- C1229
- C1230
- C1231
- C1232
- C1233
- C1234
- C1235
- C1236
- C1237
- C1238
- C1239
- C1240
- C1241
- C1242
- C1243
- C1244
- C1245
- C1246
- C1247
- C1248
- C1249
- C1250
- C1251
- C1252
- C1253
- C1254
- C1255
- C1256
- C1257
- C1258
- C1259
- C1260
- C1261
- C1262
- C1263
- C1264
- C1265
- C1266
- C1267
- C1268
- C1269
- C1270
- C1271
- C1272
- C1273
- C1274
- C1275
- C1276
- C1277
- C1278
- C1279
- C1280
- C1281
- C1282
- C1283
- C1284
- C1285
- C1286
- C1287
- C1288
- C1289
- C1290
- C1291
- C1292
- C1293
- C1294
- C1295
- C1296
- C1297
- C1298
- C1299
- C1300
- C1301
- C1302
- C1303
- C1304
- C1305
- C1306
- C1307
- C1308
- C1309
- C1310
- C1311
- C1312
- C1313
- C1314
- C1315
- C1316
- C1317
- C1318
- C1319
- C1320
- C1321
- C1322
- C1323
- C1324
- C1325
- C1326
- C1327
- C1328
- C1329
- C1330
- C1331
- C1332
- C1333
- C1334
- C1335
- C1336
- C1337
- C1338
- C1339
- C1340
- C1341
- C1342
- C1343
- C1344
- C1345
- C1346
- C1347
- C1348
- C1349
- C1350
- C1351
- C1352
- C1353
- C1354
- C1355
- C1356
- C1357
- C1358
- C1359
- C1360
- C1361
- C1362
- C1363
- C1364
- C1365
- C1366
- C1367
- C1368
- C1369
- C1370
- C1371
- C1372
- C1373
- C1374
- C1375
- C1376
- C1377
- C1378
- C1379
- C1380
- C1381
- C1382
- C1383
- C1384
- C1385
- C1386
- C1387
- C1388
- C1389
- C1390
- C1391
- C1392
- C1393
- C1394
- C1395
- C1396
- C1397
- C1398
- C1399
- C1400
- C1401
- C1402
- C1403
- C1404
- C1405
- C1406
- C1407
- C1408
- C1409
- C1410
- C1411
- C1412
- C1413
- C1414
- C1415
- C1416
- C1417
- C1418
- C1419
- C1420
- C1421
- C1422
- C1423
- C1424
- C1425
- C1426
- C1427
- C1428
- C1429
- C1430
- C1431
- C1432
- C1433
- C1434
- C1435
- C1436
- C1437
- C1438
- C1439
- C1440
- C1441
- C1442
- C1443
- C1444
- C1445
- C1446
- C1447
- C1448
- C1449
- C1450
- C1451
- C1452
- C1453
- C1454
- C1455
- C1456
- C1457
- C1458
- C1459
- C1460
- C1461
- C1462
- C1463
- C1464
- C1465
- C1466
- C1467
- C1468
- C1469
- C1470
- C1471
- C1472
- C1473
- C1474
- C1475
- C1476
- C1477
- C1478
- C1479
- C1480
- C1481
- C1482
- C1483
- C1484
- C1485
- C1486
- C1487
- C1488
- C1489
- C1490
- C1491
- C1492
- C1493
- C1494
- C1495
- C1496
- C1497
- C1498
- C1499
- C1500
- C1501
- C1502
- C1503
- C1504
- C1505
- C1506
- C1507
- C1508
- C1509
- C1510
- C1511
- C1512
- C1513
- C1514
- C1515
- C1516
- C1517
- C1518
- C1519
- C1520
- C1521
- C1522
- C1523
- C1524
- C1525
- C1526
- C1527
- C1528
- C1529
- C1530
- C1531
- C1532
- C1533
- C1534
- C1535
- C1536
- C1537
- C1538
- C1539
- C1540
- C1541
- C1542
- C1543
- C1544
- C1545
- C1546
- C1547
- C1548
- C1549
- C1550
- C1551
- C1552
- C1553
- C1554
- C1555
- C1556
- C1557
- C1558
- C1559
- C1560
- C1561
- C1562
- C1563
- C1564
- C1565
- C1566
- C1567
- C1568
- C1569
- C1570
- C1571
- C1572
- C1573
- C1574
- C1575
- C1576
- C1577
- C1578
- C1579
- C1580
- C1581
- C1582
- C1583
- C1584
- C1585
- C1586
- C1587
- C1588
- C1589
- C1590
- C1591
- C1592
- C1593

CIRCUIT DIAGRAM (TOP RIGHT)

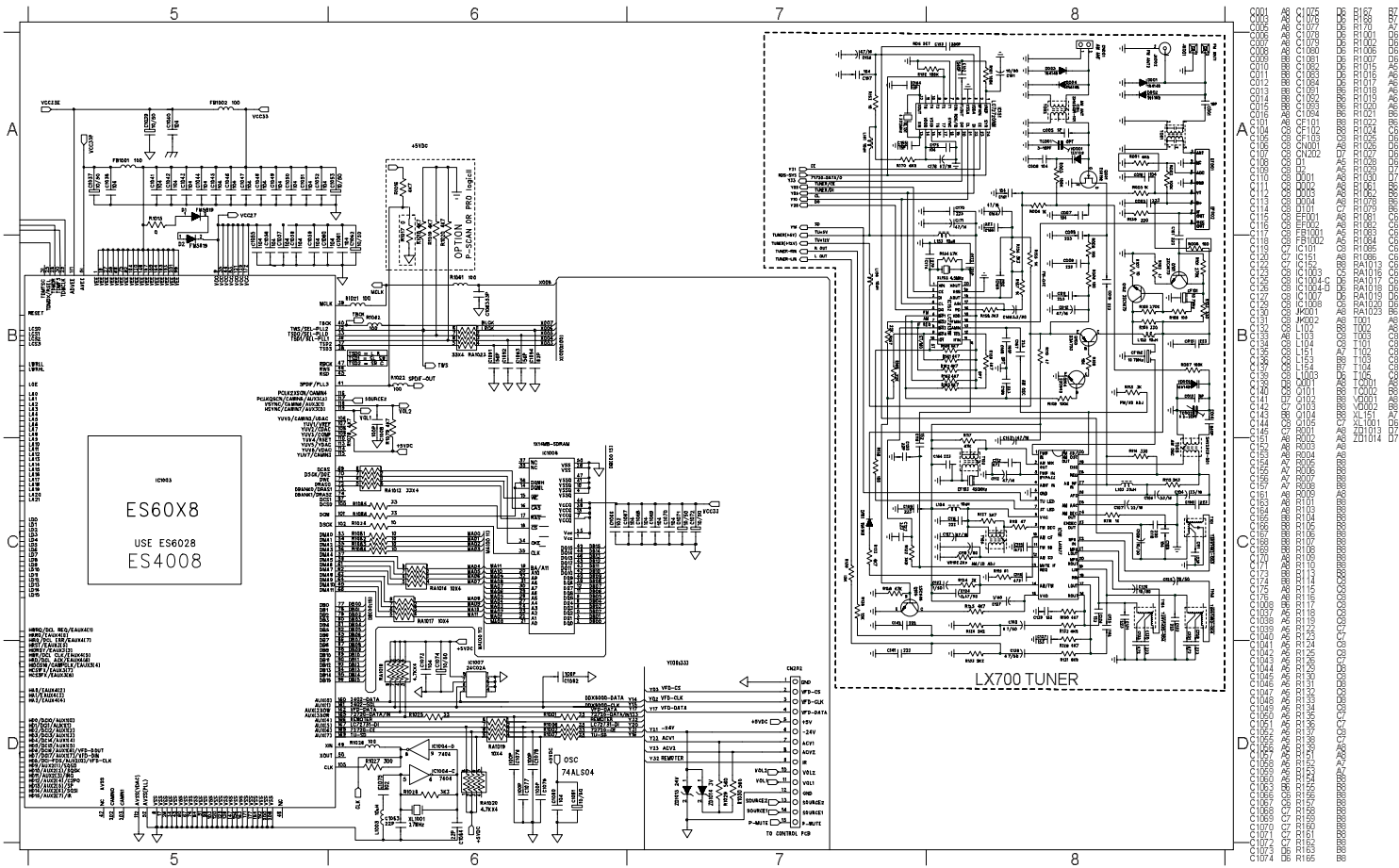

CIRCUIT DIAGRAM (BOTTOM LEFT)

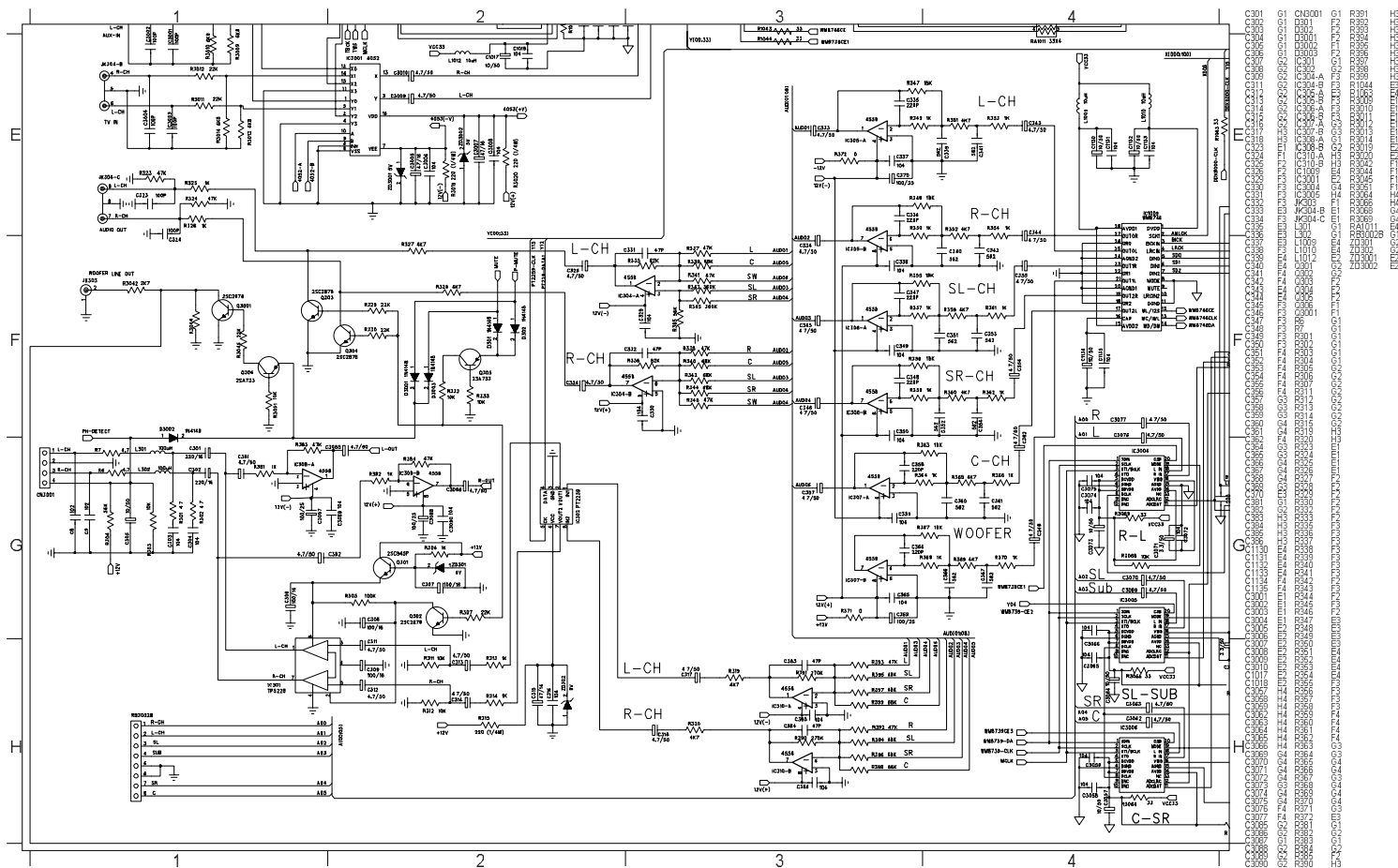

CIRCUIT DIAGRAM (BOTTOM RIGHT)

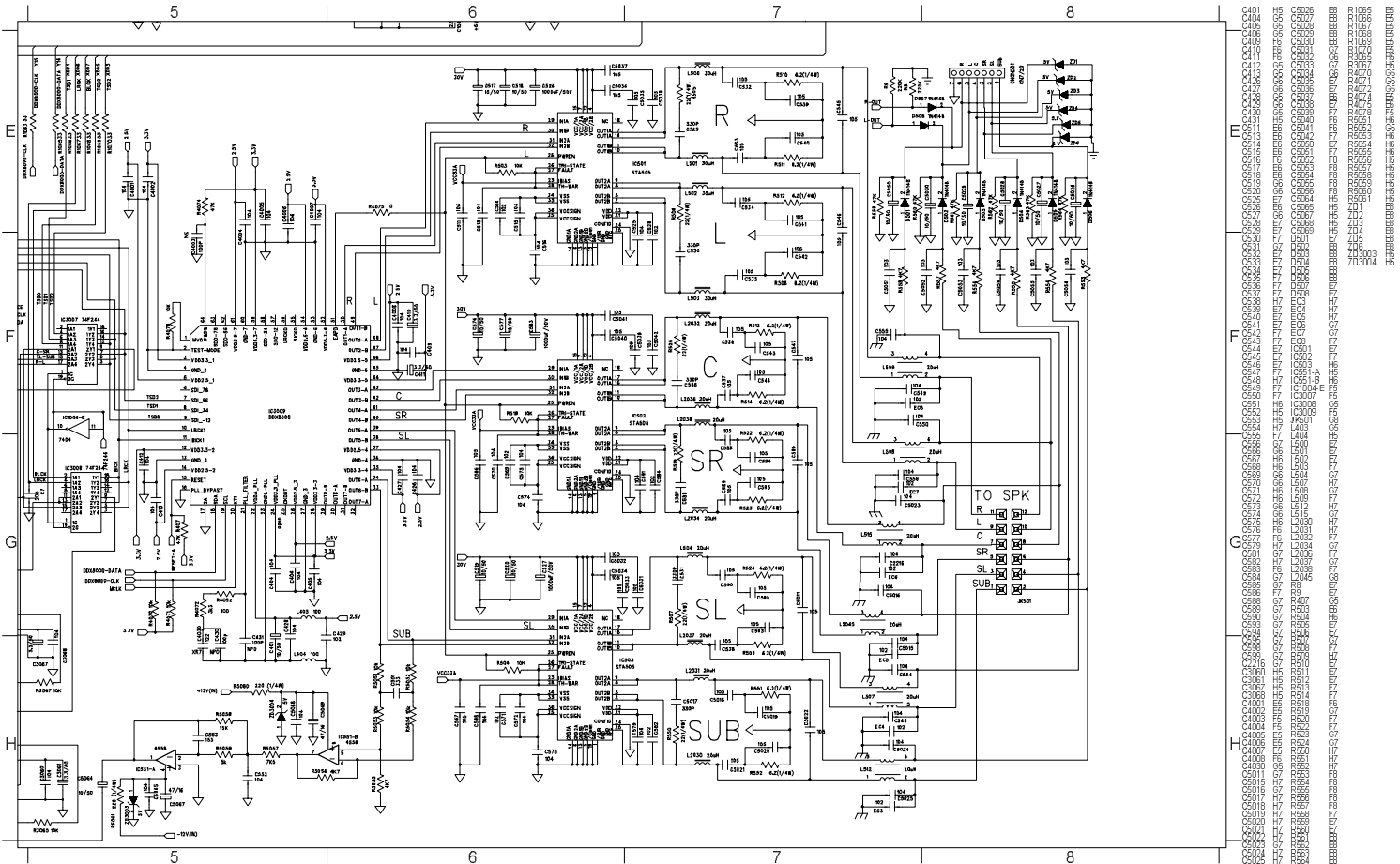

PCB LAYOUT (COMPONENT VIEW)

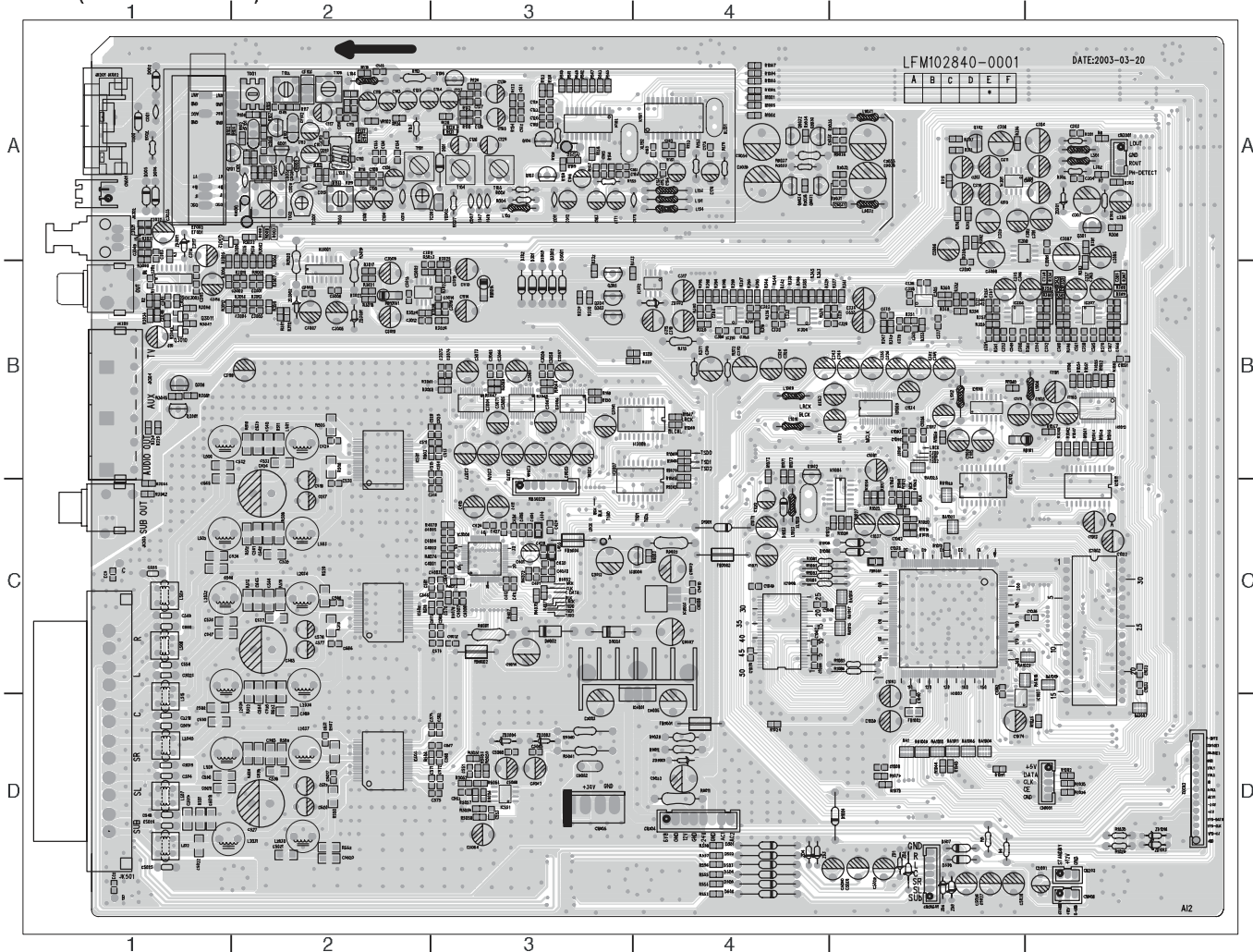



## LAYOUT MAPPING (COMPONENT VIEW)

C10	B1	C381	A6	C1114	B3	D002	A1	Q1002	B4	R364	B6	R3011	B2
C001	A1	C382	A6	C1115	B5	D003	A1	Q3001	B1	R365	B6	R3012	B1
C005	A2	C383	B4	C1120	C4	D004	A1	Q3010	B1	R366	B6	R3013	B2
C006	A2	C384	B4	C1130	B4	D101	A3	Q3011	B1	R367	B6	R3014	B2
C007	A3	C385	B4	C1132	B5	D301	B3	Q3012	A1	R368	B6	R3017	B2
C008	A2	C386	B4	C1134	B5	D302	B3	Q9031	A4	R369	B6	R3018	B2
C009	A2	C401	C3,3	C2001	D6	D501	D4	Q9032	A4	R370	B6	R3019	A2
C010	A2	C404	C3,3	C2216	D1	D502	D4	Q9033	A4	R371	B4	R3020	B2
C011	A3	C405	C3,3	C3001	B2	D503	D4	Q9034	A4	R372	B4	R3021	B2
C012	A3	C406	C3,3	C3002	B2	D504	D4	R1	B1	R381	A6	R3022	B2
C014	A2	C410	C3,3	C3003	B2	D505	D4	R2	B1	R382	A5	R3023	A2
C015	A2	C411	C3,3	C3004	B2	D506	D4	R3	A1	R383	B6	R3024	B2
C101	A2	C412	C3,3	C3005	B2	D507	D5	R4	D5	R384	A5	R3025	B2
C104	A2	C413	C3,3	C3006	B2	D508	D5	R5	D5	R385	B4	R3026	B3
C105	A2	C426	C3,3	C3007	B2	D1001	C4	R6	A6	R390	B4	R3027	B3
C106	A2	C427	C3,3	C3008	B2	D1003	C4	R7	A6	R391	B4	R3028	B3
C107	A2	C428	C3,3	C3009	A2	D1004	D5	R002	A1	R392	B4	R3031	A1
C108	A2	C429	C3,3	C3010	B2	D1005	C4	R003	A2	R393	B4	R3032	A2
C109	A2	C430	C3,3	C3011	A2	D1006	C4	R004	A3	R394	B4	R3034	B1
C110	A2	C431	C3,3	C3012	B2	D3001	B3	R005	A2	R395	B4	R3042	C1
C112	A2	C511	B3	C3013	B2	D3002	B3	R006	A3	R396	B4	R3044	C1
C113	A2	C513	B3	C3014	B3	D3003	B3	R007	A3	R397	B4	R3045	B1
C114	A2	C514	B3	C3015	B3	D9002	C3	R008	A2	R398	B4	R3046	B1
C115	A2	C515	B3	C3016	B3	D9003	C3	R009	A2	R399	B4	R3047	B1
C116	A2	C516	C3,3	C3020	B1	EC2	D1	R102	A2	R407	C3	R3048	B1
C117	A2	C517	C3,3	C3031	A1	EC9	C1	R103	A2	R503	B2	R3050	B1
C118	A2	C518	C3,3	C3032	A1	EF001	A1	R104	A2	R504	D2	R3051	B1
C119	A3	C519	D3	C3033	A1	EF002	A1	R105	A2	R505	B2	R3064	B3
C120	A3	C520	D3	C3048	B1	FB1001	C5	R106	A2	R506	B2	R3065	B3
C122	A3	C525	B3	C3049	A1	FB1002	D5	R107	A2	R507	D2	R3066	B3
C123	A2	C526	B3	C3057	B3	FB9001	D4	R108	A3	R508	C2	R3067	B3
C124	A3	C527	D3	C3058	B3	FB9002	C3	R109	A3	R509	D2	R3068	B3
C125	A3	C528	B3	C3059	B3	FB9003	C4	R110	A2	R510	B2	R3069	B3
C126	A3	C529	B3	C3061	B3	FB9004	C3	R113	A2	R511	B2	R3111	B2
C127	A3	C530	C3,3	C3062	B3	IC151	A4	R114	A2	R512	C2	R3112	B2
C134	A2	C531	D3	C3063	B3	IC152	A3	R115	A2	R513	C2	R4052	C3
C135	A2	C532	B3	C3064	B3	IC301	A5	R116	A2	R514	C2	R4070	C3
C136	A2	C533	C3,3	C3065	B3	IC302	B4	R117	A2	R518	C2	R4071	C3
C137	A3	C534	C3,3	C3066	B3	IC304	B4	R118	A2	R519	C2	R4072	C3
C138	A3	C535	C3,3	C3067	B3	IC305	B5	R119	A2	R520	C2	R4073	C3
C139	A3	C536	C3,3	C3068	B3	IC306	B5	R122	A3	R522	D2	R4074	C3
C140	A3	C537	C3,3	C3069	B3	IC307	B6	R123	A2	R523	D2	R4075	C3
C141	A3	C538	D3	C3070	B3	IC308	A6	R124	A2	R524	D2	R4078	C3
C142	A3	C539	B3	C3071	B3	IC310	B4	R125	A3	R550	D2	R5051	D3
C143	A2	C540	B3	C3073	B3	IC501	B2	R126	A3	R551	D1	R5052	D3
C144	A2	C541	C3,3	C3074	B3	IC502	C2	R129	A3	R552	D2	R5053	D3
C145	A2	C542	C3,3	C3075	B3	IC503	D2	R130	A3	R553	D4	R5054	D3
C151	A4	C543	C3,3	C3076	B3	IC551	D3	R131	A3	R554	D4	R5055	D3
C152	A4	C544	C3,3	C3077	B3	IC1002	C6	R132	A3	R555	D4	R5056	D3
C153	A4	C545	C3,3	C3085	A6	IC1003	C5	R133	A3	R556	D4	R5057	D3
C156	A4	C546	C3,3	C3086	A5	IC1004	B5	R134	A3	R557	D4	R5058	D3
C157	A4	C547	C3,3	C3087	A6	IC1007	C6	R135	A2	R558	D4	R5059	D3
C161	A4	C548	D1	C3088	B5	IC1008	C4	R136	A2	R1001	A4	R5060	D3
C163	A3	C549	C1	C3089	A6	IC1009	B5	R137	A2	R1002	A4	R5061	D3
C164	A4	C550	C1	C3090	B5	IC1011	C6	R138	A3	R1003	A4	R9001	C3
C165	A3	C551	D3	C3111	B1	IC1012	C5	R149	B3	R1004	A4	R9002	C4
C166	A3	C552	D3	C3112	B1	IC1013	B6	R150	B3	R1005	A4	R9003	C4
C167	A3	C553	D3	C3113	A1	IC1015	B5	R151	A4	R1006	A4	R9011	D4
C168	A3	C554	D1	C3114	A1	IC3001	A2	R152	A4	R1007	A4	R9012	D4
C169	A3	C555	C1	C3115	B1	IC3002	B2	R153	A4	R1012	C5	R9031	A5
C170	A4	C556	C1	C3116	B1	IC3002	B1	R155	A4	R1013	C4	R9032	A5

## LAYOUT MAPPING (COPPERSIDE VIEW)

C1	B6	C5032	D5
C2	B5	C5033	D5
C3	B5	C5034	D5
C4	A6	C5035	B5
C5	A1	C5036	B5
C6	B2	C5037	B5
C7	B3	C5038	C5
C8	A1	C5039	C5
C8	A1	C5040	C5
C11	A3	C5041	C5
C003	A6	C5042	C5
C013	A5	C5051	D3
C016	A6	C5052	D3
C111	A5	C5053	D3
C129	A4	C5054	D3
C130	A4	C5055	D3
C131	A4	C5056	D3
C132	A4	C9004	D3
C133	A4	C9006	D3
C154	A3	C9011	C3
C155	A3	C9023	D3
C173	A4	C9032	A2
C174	A4	C9035	A3
C316	B3	C9037	A2
C323	B6	C9040	A3
C324	B6	EC1	D6
C409	C4	EC3	D6
C1001	A3	EC4	D6
C1002	A3	EC5	D6
C1003	A3	EC7	C6
C1004	A3	EC8	C6
C1005	A3	EC9	D6
C1006	A3	IC101	A5
C1007	A3	R9	D2
C1018	B2	R10	A3
C1023	C1	R001	A6
C1024	C2	R101	A6
C1041	C2	R139	A6
C1042	C2	R154	A3
C1043	C2	R323	B6
C1044	C2	R324	B6
C1045	C2	R559	D3
C1046	C2	R560	D3
C1047	C2	R561	D3
C1048	C2	R562	D3
C1049	C2	R563	D3
C1050	C2	R564	D3
C1051	C2	R1028	C3

PCB LAYOUT (COPPER SIDE VIEW)

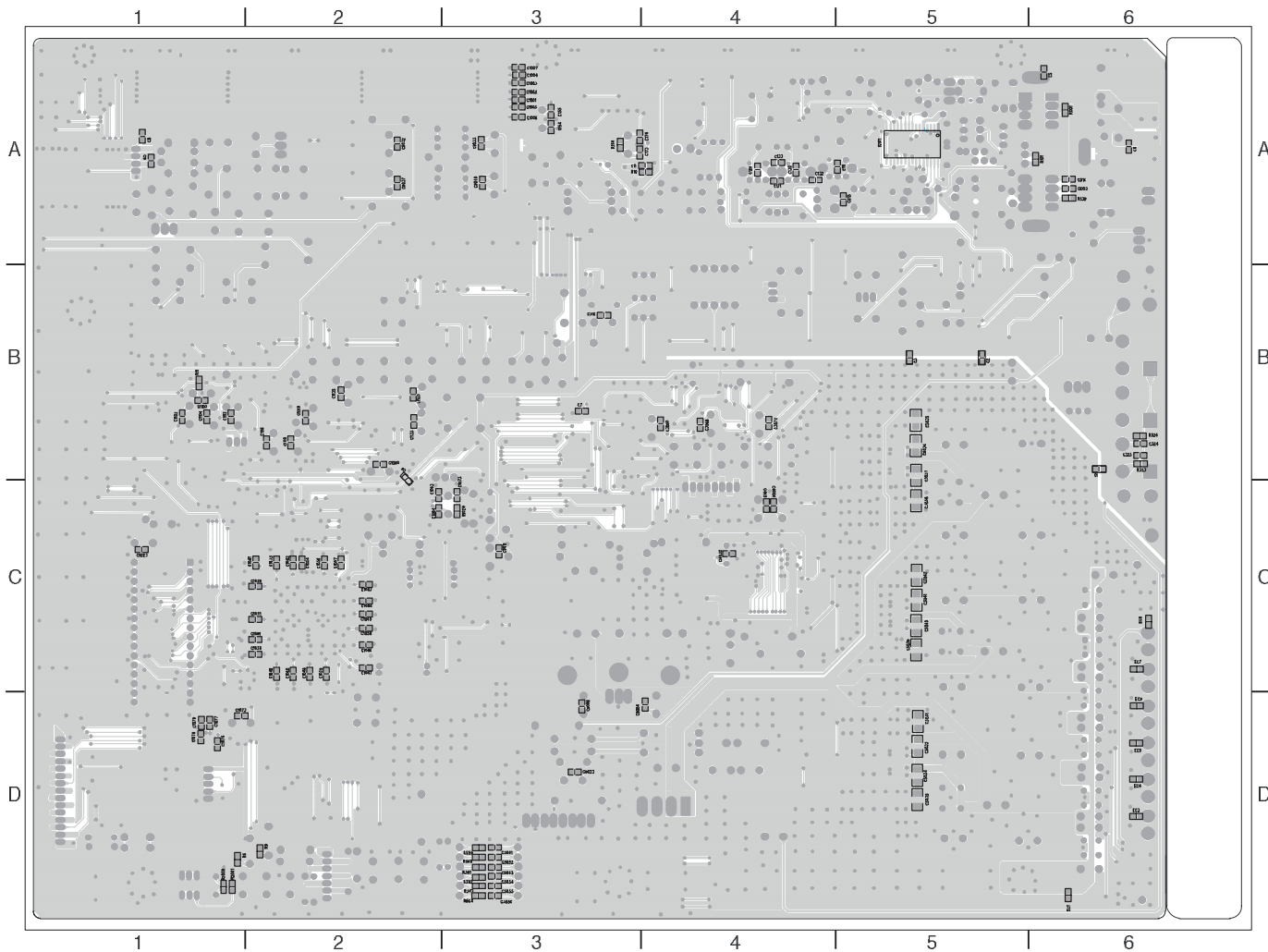



EXPLODED DRAWING

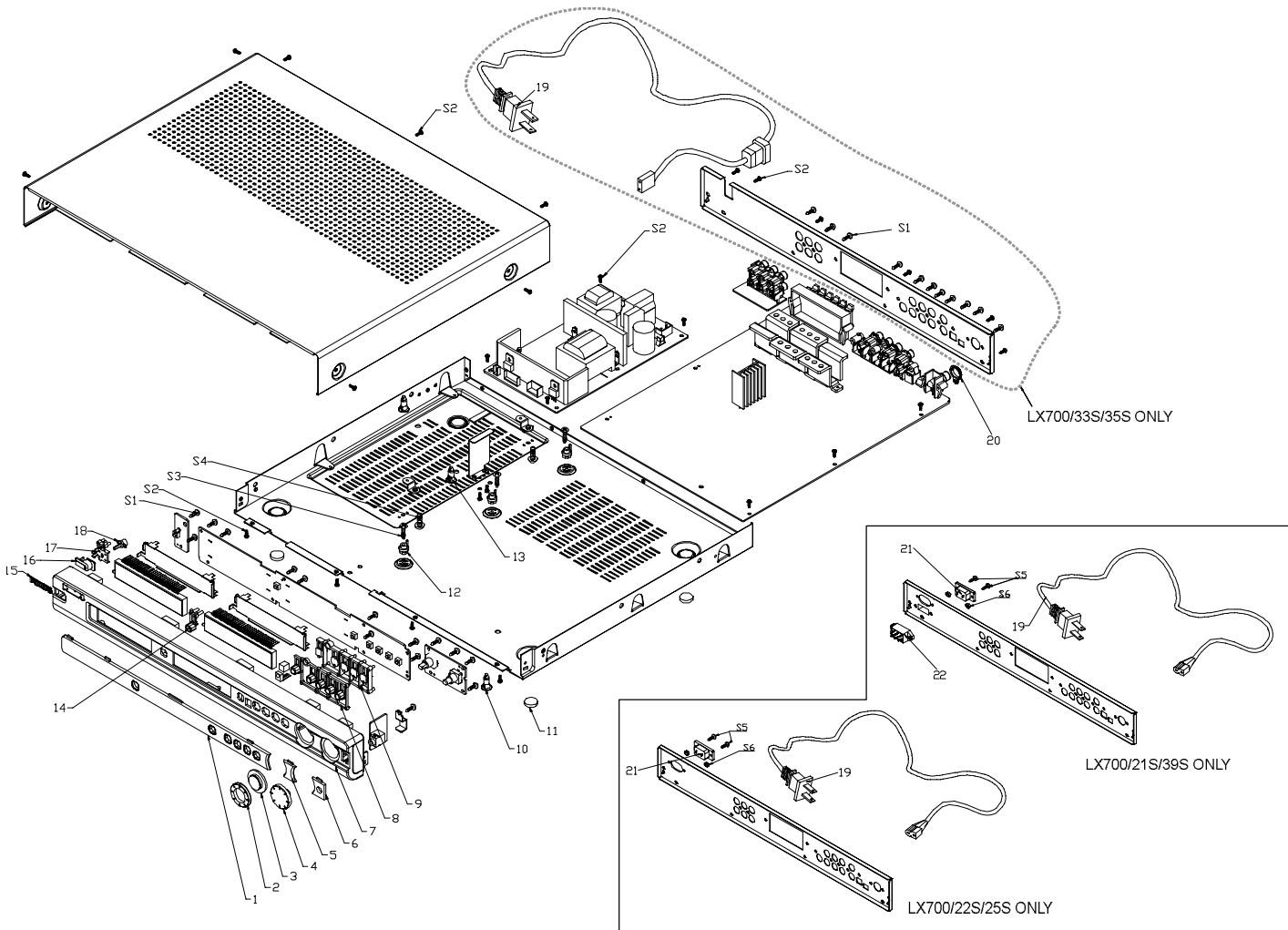

**MECHANICAL & ACCESSORIES PARTSLIST**

1	9965 000 17343	DISPLAY LENS
2	9965 000 17344	SOURCE LENS
3	9965 000 17340	SOURCE KNOB
4	9965 000 17336	VOLUME KNOB
5	9965 000 17346	LENS-2
6	9965 000 17347	LENS-3
7	9965 000 17335	FRONT CABINET
8	9965 000 17338	FUNCTION KEY
9	9965 000 17339	FUNCTION KEY BRACKET
10	9965 000 17354	SPACER
11	9965 000 17349	RUBBER FOOT
12	9965 000 17356	PLASTIC BRACKET
13	9965 000 17355	SPACER
14	9965 000 17337	SURROUND KEY
15	9965 000 12424	PHILIPS LOGO
16	9965 000 17342	POWER KEY COVER
17	9965 000 17341	POWER KEY
18	9965 000 17345	LED LENS
19	△9965 000 15983	MAINS CORD /21S/22S
19	△9965 000 17457	MAINS CORD /25S
20	9965 000 12441	FM JACK HOLDER
21	△9965 000 17353	AC SOCKET
22	△9965 000 16339	VOLTAGE SELECTOR /21S
	9965 000 17348	REMOTE CONTROL
	9965 000 17350	IFU
	9965 000 17351	SUBWOOFER ASS'Y
	9965 000 17352	SAT SPK ASSY
	9965 000 14636	RCA CABLE
	4822 303 50063	FM AERIAL
	2422 549 45067	AM FRAME AERIAL

**Note:** Only these parts mentioned in the list are normal service parts.