

SD

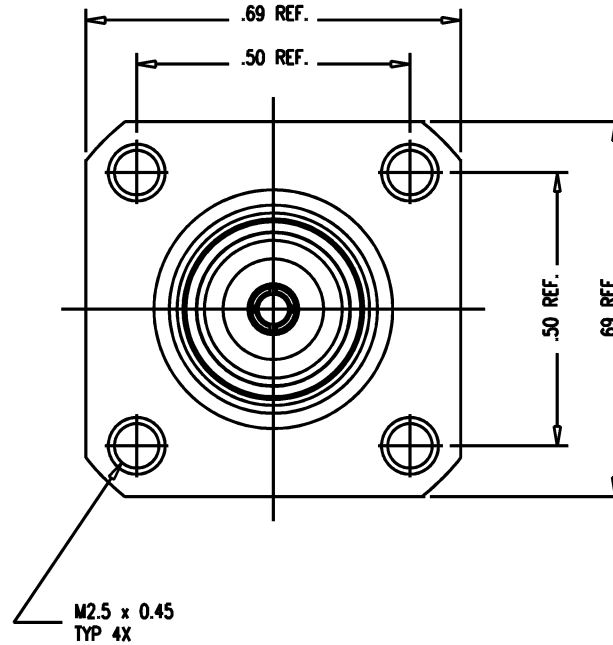
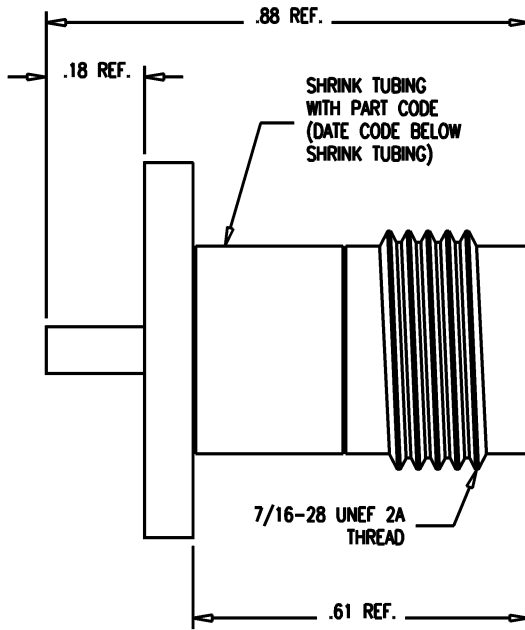

NOTES:

1. INTERFACE TO BE IN ACCORDANCE WITH MIL-STD-348 FIG. 313-2.
2. MATERIALS:
 INSULATOR-TEFLON, ASTM-D-4894
 CENTER CONTACT-BER. COP., ASTM-B-196
 SHRINK TUBING-POLYOLEFIN PER MIL-I-23053/5
 BODY-BRASS, ASTM-B16
3. FINISHES:
 CENTER CONTACT-GOLD PLATE PER MIL-G-45204
 BODY-SILVER PLATE PER QQ-S-365
4. ELECTRICAL CHARACTERISTICS:
 NOMINAL IMPEDANCE-50 OHMS
 FREQUENCY RANGE-DC TO 1.10 GHZ
 WORKING VOLTAGE-500 VOLTS RMS
 VSWR: 1.07 MAX.

KINGS P/N	CODE	MARKING
127-36-1	J1	J1
127-36-2	J2	J2
127-36-3	J3	J3
127-36-4	J4	J4

127-37-*

REVISIONS

ISSUE	CHANGES
0	ER 38041 JPK 06/30/00
1	CN 38048 D JPK 07/12/00
2	CN 38309 D TML 05/15/2001

127-37D

SCALE 4:1	
APPROX SURFACE AREA	
USED ON 127-37-*	
REF: E-19833	
RCPT, PNL, TNC	
DRAWN J KENNEDY	DATE 06/30/00
DESIGN J KENNEDY	DATE 06/30/00
APPR.	DATE
 ROCK HILL, SOUTH CAROLINA 29730	

SD

127-37-*