

NOTES:

1. CONTACT CONFIGURATION NOT AVAILABLE AS STANDARD.
2. Ⓢ REPRESENTS A CRITICAL DIMENSION.
3. MAXIMUM BURR ALLOWANCE: .038 [.0015].
4. MINIMUM PUSHOUT FORCE: 2.22N [.5 LB].
5. PARTS TO BE PACKAGED IN TRAYS.

REVISION

0	DF	S HILLERICH
4/3/2007 ECN-74132 ISSUE FOR REVIEW.		
0	DF	D FRALEY
3/24/2008 ECN-88099 ISSUE FOR REVIEW.		
A	TP	D Fletcher
4/29/2008 ECN-89954 RELEASE FOR PRODUCTION; CHG TRAY TY-ERM8042-11-5 TO TY-ERM8057-11-5-L		
B	MM	E Fox
6/1/2009 ECN-111187 FRONT VIEW: CHG DIM "14.16" TO "13.70".		

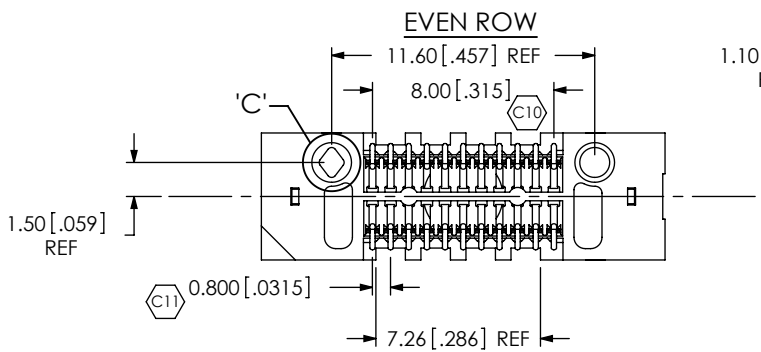
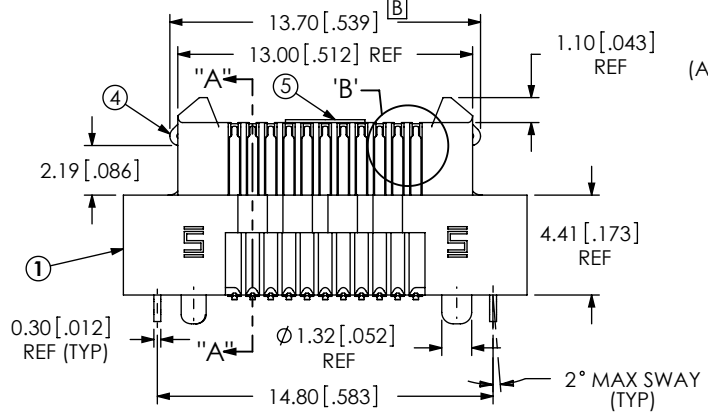
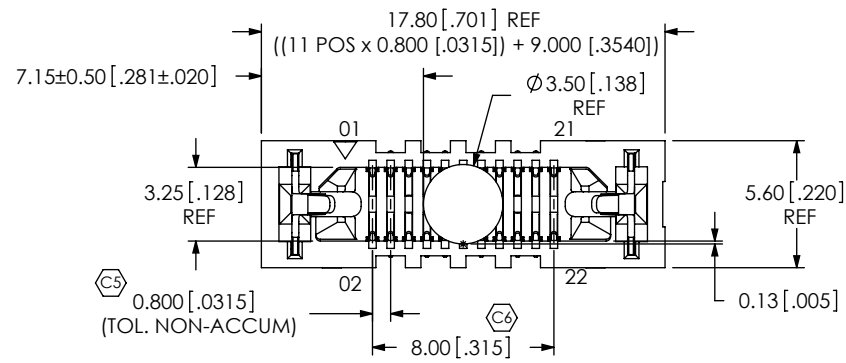

0.64 [.025] REF (APPLIES TO ALL OTHER SIGNALS)

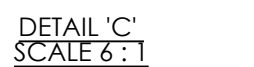
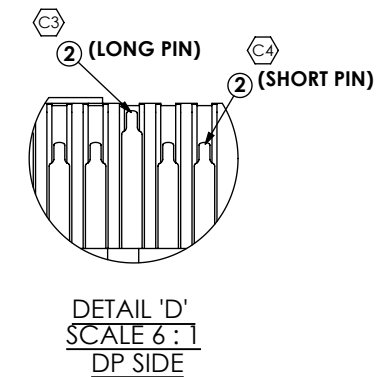
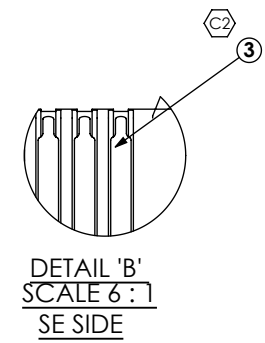
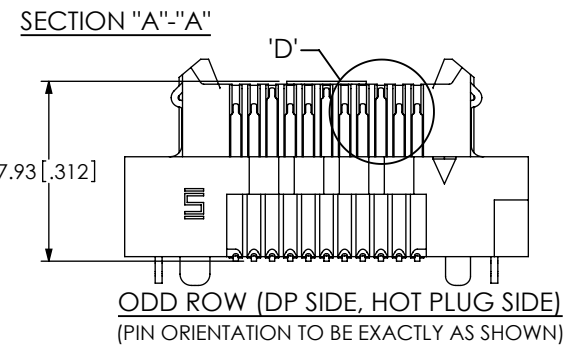
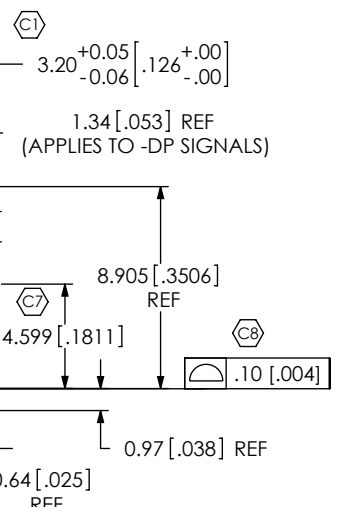

ACCEPTANCE OF DRAWING  
ACCEPTED WITH DEVIATIONS LISTED

DATE: \_\_\_\_\_  
COMPANY: \_\_\_\_\_  
CUSTOMER SIGNATURE  
PRINTED NAME  
PHONE NO: \_\_\_\_\_  
FAX NO: \_\_\_\_\_

ITEM NO.	PART NUMBER	QUANTITY	MATERIAL
1	ERM8-011-05.0-DV-L	1.00000	VECTRA E130i, COLOR: BLACK
2	T-1M48-05.0-S	11.00000	PHOS BRONZE, 521 HARD TEMPER
3	T-1M37-05.0	11.00000	PHOS BRONZE, 521 HARD TEMPER
4	WT-29-03-F	2.00000	BeCu #25, 1/2 HT
5	K-500-300	1.00000	POLYIMIDE FILM (KAPTON)
6	TY-ERM8057-11-5-L	1.00000	BLACK HIPS

UNLESS OTHERWISE SPECIFIED, DIMENSIONS ARE IN INCHES. TOLERANCES ARE: DECIMALS ANGLES .X: ±.3[.01] .XX: ±.13[.005] .XXX: ±.051[.0020]	PROPRIETARY NOTE THIS DOCUMENT CONTAINS INFORMATION CONFIDENTIAL AND PROPRIETARY TO SAMTEC, INC. AND SHALL NOT BE REPRODUCED OR TRANSFERRED TO OTHER DOCUMENTS OR DISCLOSED TO OTHERS OR USED FOR ANY PURPOSE OTHER THAN THAT WHICH IT WAS OBTAINED WITHOUT THE EXPRESSED WRITTEN CONSENT OF SAMTEC, INC.	 520 PARK EAST BLVD., NEW ALBANY, IN 47150 PHONE: 812-944-6733 FAX: 812-948-5047 e-Mail: info@SAMTEC.com code: 55322
	DO NOT SCALE DRAWING SHEET SCALE: 1:0.333333	
PLATING: CONTACT AREA: .000030 GOLD OVER .000050 NICKEL REMAINDER: .000200 REF TIN OVER .000050 NICKEL LATCHES: .000003 GOLD OVER .000050 NICKEL		DESCRIPTION: MODIFIED ERM8 ASSEMBLY
		DWG. NO. ASP-137968-01
		BY: David F 01/24/2008 SHEET 1 OF 2

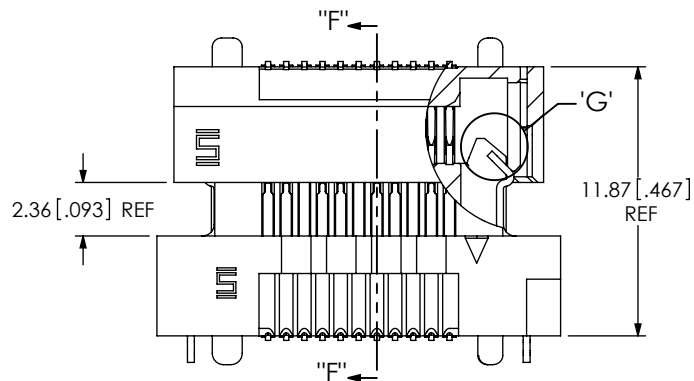

LATCH ENGAGING VIEW

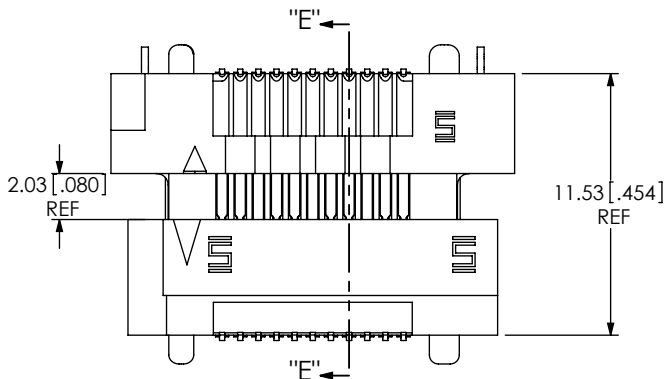

PIN ENGAGING VIEW

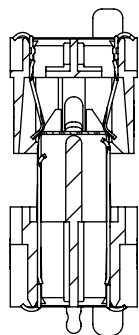

SECTION "F"-"F"

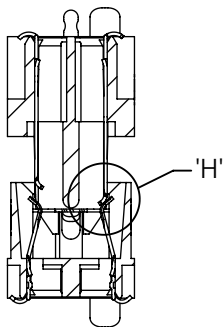

SECTION "E"-"E"

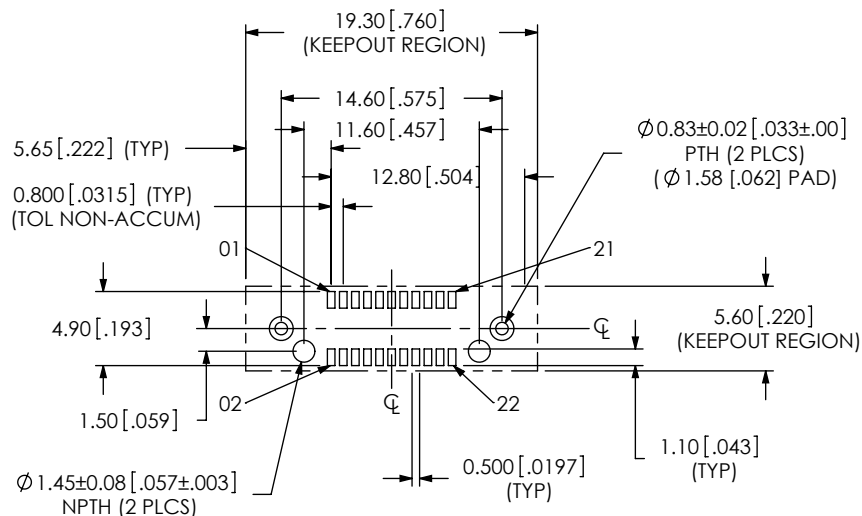

RECOMMENDED PCB LAYOUT

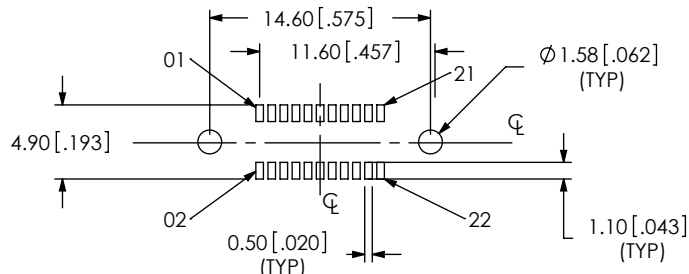

RECOMMENDED STENCIL LAYOUT

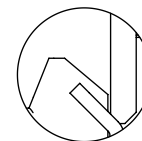

DETAIL 'G'  
SCALE 6 : 1

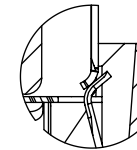

DETAIL 'H'  
SCALE 6 : 1

PROPRIETARY NOTE

THIS DOCUMENT CONTAINS INFORMATION CONFIDENTIAL AND PROPRIETARY TO SAMTEC, INC. AND SHALL NOT BE REPRODUCED OR TRANSFERRED TO OTHER DOCUMENTS OR DISCLOSED TO OTHERS OR USED FOR ANY PURPOSE OTHER THAN THAT WHICH IT WAS OBTAINED WITHOUT THE EXPRESSED WRITTEN CONSENT OF SAMTEC, INC.



SHEET SCALE: 3:1

DESCRIPTION: MODIFIED ERM8 ASSEMBLY

DWG. NO. ASP-137968-01