

Wideband RF LDMOS Integrated Power Amplifier 30 W, 700 – 1000 MHz

Description

The PTMA080302M is a wideband, matched, 30-watt, 2-stage LDMOS integrated amplifier intended for use in all typical modulation formats from 700 to 1000 MHz. This device is offered in a 20-lead, thermally-enhanced, overmolded package for cool and reliable operation.

PTMA080302M
Package PG-DSO-20-63

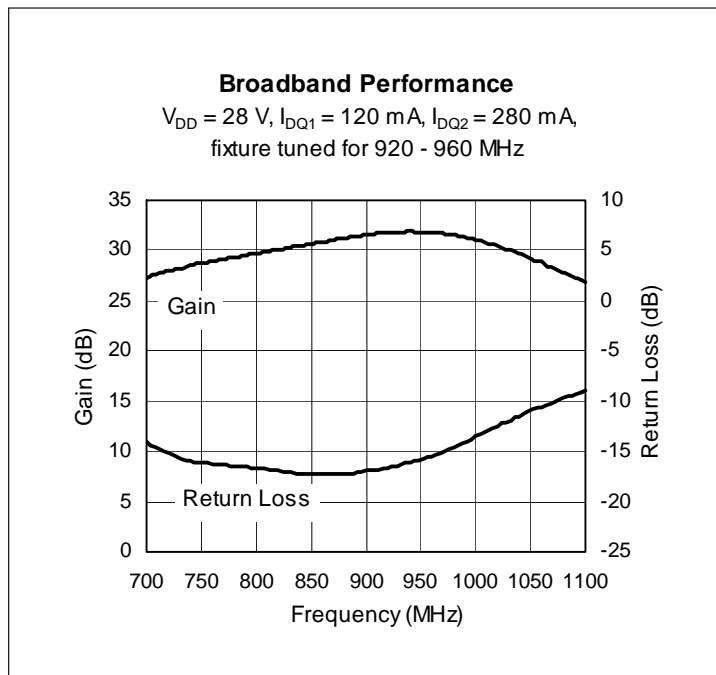

Features

- Designed for wide RF modulation bandwidths, and low memory effects
- On-chip matching, integrated input DC block, 50-ohm input and ~ 8-ohm output
- Typical GSM/EDGE performance, 940 MHz, 28 V
 - Output power = 15 W Avg.
 - Linear gain = 31 dB
 - Power added efficiency = 36%
 - EVM at 15 W = 1.7 %
 - ACPR at 400 kHz = -61 dBc
 - ACPR at 600 kHz = -73 dBc
- Typical CW performance at 940 MHz, 28 V
 - Output power at P-1dB = 32 W
 - Linear gain (1 W) = 31 dB
 - Power added efficiency = 46%
- Capable of handling 10:1 VSWR @ 28 V, 30 W (CW) output power
- Integrated ESD protection. Meets HBM Class 1B (minimum), per JESD22-A114F
- RoHS-compliant package

RF Characteristics

GSM/EDGE Measurements (not subject to production test—verified by design/characterization in Infineon test fixture)

$V_{DD} = 28\text{ V}$, $I_{DQ1} = 120\text{ mA}$, $I_{DQ2} = 280\text{ mA}$, $f = 920\text{ to }960\text{ MHz}$, $P_{OUT} = 15\text{ W Avg.}$

Characteristic	Symbol	Min	Typ	Max	Unit
Gain	G_{ps}	—	31	—	dB
Power-added Efficiency	PAE	—	36	—	%
Error Vector Magnitude	EVM (RMS)	—	1.7	—	%

All published data at $T_{CASE} = 25^{\circ}\text{C}$ unless otherwise indicated

ESD: Electrostatic discharge sensitive device—observe handling precautions!

RF Characteristics (cont.)

GSM/EDGE Measurements (cont.)

 $V_{DD} = 28\text{ V}$, $I_{DQ1} = 120\text{ mA}$, $I_{DQ2} = 280\text{ mA}$, $f = 920\text{ to }960\text{ MHz}$, $P_{OUT} = 15\text{ W Avg.}$

Characteristic		Symbol	Min	Typ	Max	Unit
Modulation Spectrum	400 kHz offset	ACPR ₁	—	-61	—	dBc
	600 kHz offset	ACPR ₂	—	-73	—	dBc
Input Return Loss		IRL	—	-15	—	dB
Gain Flatness		ΔG	—	0.2	—	dB

Two-tone Measurements (tested in Infineon test fixture)

 $V_{DD} = 28\text{ V}$, $I_{DQ1} = 120\text{ mA}$, $I_{DQ2} = 280\text{ mA}$, $P_{OUT} = 32\text{ W PEP}$, $f = 940\text{ MHz}$, tone spacing = 1 MHz

Characteristic		Symbol	Min	Typ	Max	Unit
Gain		G _{ps}	31	32	—	dB
Power-added Efficiency		PAE	34	35	—	%
Intermodulation Distortion		IMD	—	-33	-31	dBc

Single-tone Measurements (not subject to production test—verified by design/characterization in Infineon test fixture)

 $V_{DD} = 28\text{ V}$, $I_{DQ1} = 120\text{ mA}$, $I_{DQ2} = 280\text{ mA}$, $f = 940\text{ MHz}$

Characteristic		Symbol	Min	Typ	Max	Unit
Gain		G _{ps}	—	32	—	dB
Power-added Efficiency		PAE	—	46	—	%
Output Power		P-1dB	—	31	—	W

DC Characteristics

Characteristic		Conditions	Symbol	Min	Typ	Max	Unit
Drain-Source Breakdown Voltage		$V_{GS} = 0\text{ V}$, $I_{DS} = 10\text{ mA}$	$V_{(BR)DSS}$	65	—	—	V
Drain Leakage Current		$V_{DS} = 28\text{ V}$, $V_{GS} = 0\text{ V}$	I_{DSS}	—	—	1.0	μA
		$V_{DS} = 63\text{ V}$, $V_{GS} = 0\text{ V}$	I_{DSS}	—	—	10.0	μA
On-State Resistance	Stage 1	$V_{GS} = 10\text{ V}$, $V_{DS} = 0.1\text{ V}$	$R_{DS(on)}$	—	0.25	—	Ω
	Stage 2	$V_{GS} = 10\text{ V}$, $V_{DS} = 0.1\text{ V}$	$R_{DS(on)}$	—	1.85	—	Ω
Operating Gate Voltage		$V_{DS} = 28\text{ V}$, $I_{DQ1} = 120\text{ mA}$, $I_{DQ2} = 280\text{ mA}$	V_{GS}	2.0	2.5	3.0	V
Gate Leakage Current		$V_{GS} = 10\text{ V}$, $V_{DS} = 0\text{ V}$	I_{GSS}	—	—	1.0	μA

Maximum Ratings

Parameter	Symbol	Value	Unit
Drain-Source Voltage	V_{DSS}	65	V
Gate-Source Voltage	V_{GS}	-0.5 to +12	V
Junction Temperature	T_J	200	°C
Input Power	P_{IN}	16	dBm
Total Device Dissipation	P_D	129.5	W
Above 25°C derate by		0.74	W/°C
Storage Temperature Range	T_{STG}	-40 to +150	°C
Thermal Resistance ($T_{CASE} = 70^\circ\text{C}$) Stage 1	$R_{\theta JC}$	6.7	°C/W
Stage 2	$R_{\theta JC}$	1.7	°C/W

Moisture Sensitivity Level

Level	Test Standard	Package Temperature	Unit
3	IPC/JEDEC J-STD-020	260	°C

Ordering Information

Type and Version	Package Outline	Package Description	Shipping
PTMA080302M V1	PG-DSO-20-63	Copper heat slug, plastic EMC body	Tape

Typical Performance (data taken in a production test fixture)

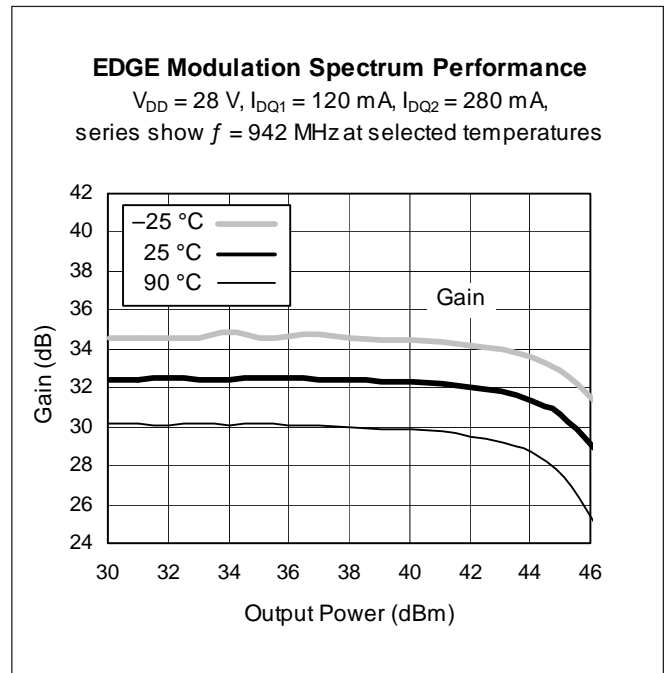
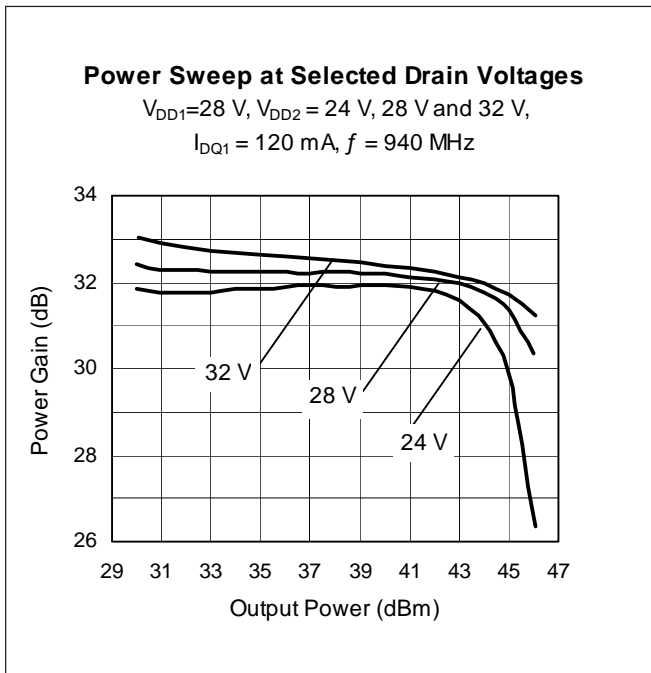
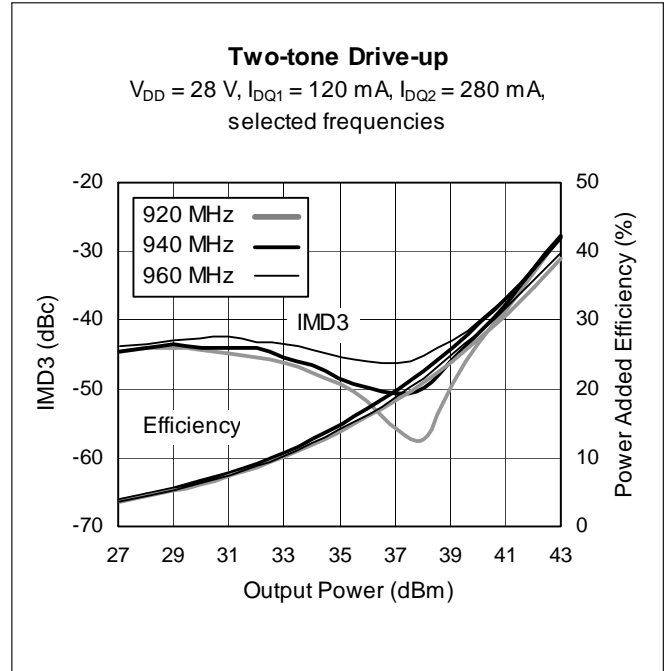
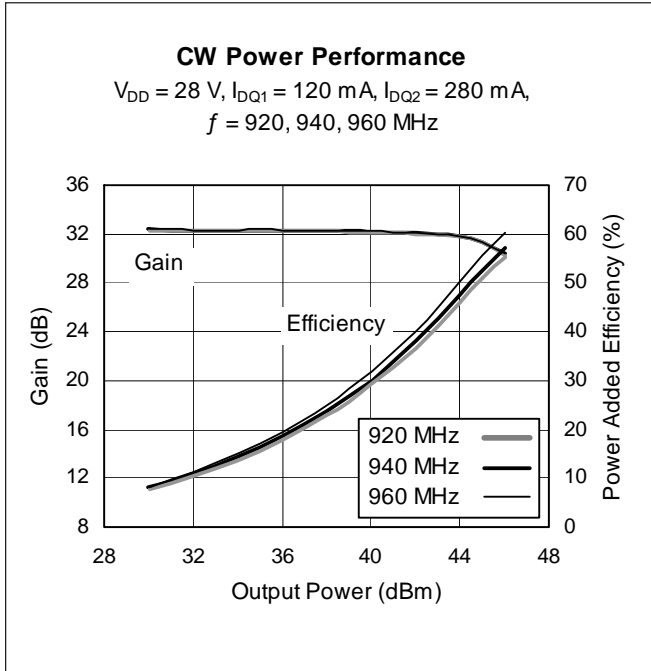

Typical Performance (cont.)

EDGE Modulation Spectrum Performance

$V_{DD} = 28\text{ V}$, $I_{DQ1} = 120\text{ mA}$, $I_{DQ2} = 280\text{ mA}$, series show $f = 942\text{ MHz}$ at selected temperatures

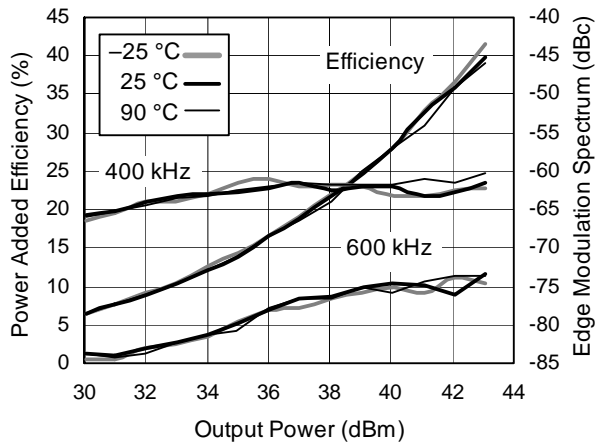

EDGE Modulation Spectrum Performance

$V_{DD} = 28\text{ V}$, $I_{DQ1} = 120\text{ mA}$, $I_{DQ2} = 280\text{ mA}$, series are at selected frequencies

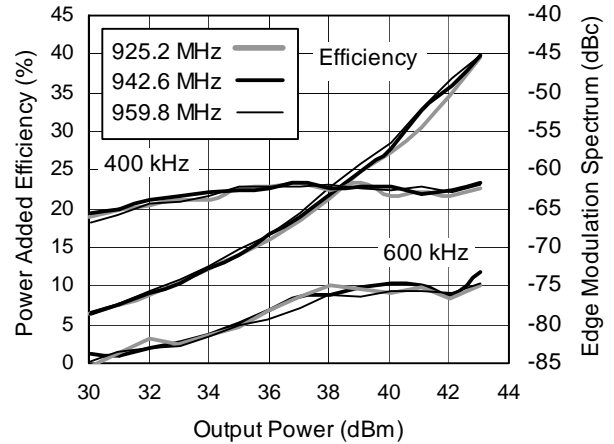

EDGE EVM

$V_{DD} = 28\text{ V}$, $I_{DQ1} = 120\text{ mA}$, $I_{DQ2} = 280\text{ mA}$, series show $f = 942\text{ MHz}$ at selected temperatures

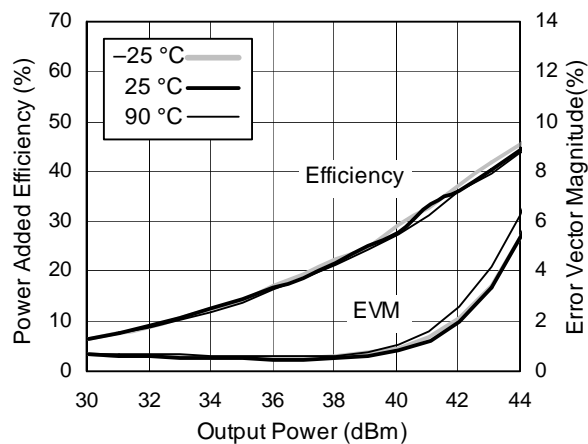

EDGE EVM

$V_{DD} = 28\text{ V}$, $I_{DQ1} = 120\text{ mA}$, $I_{DQ2} = 280\text{ mA}$, series are at selected frequencies

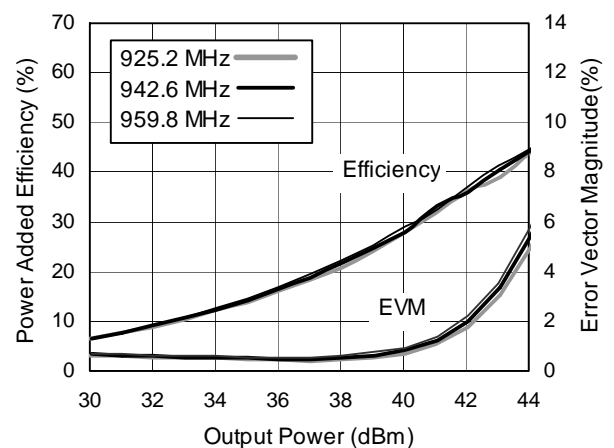

Typical Performance (cont.)

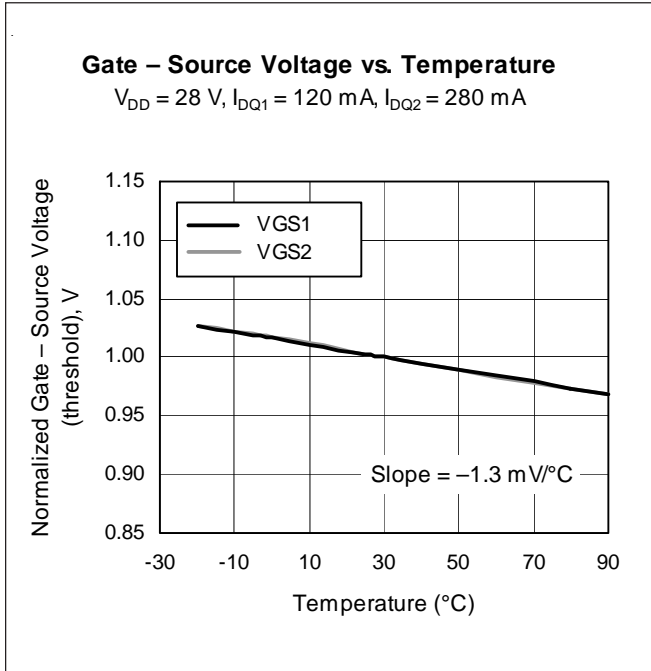

Broadband Circuit Impedance

Frequency MHz	Z Load Ω	
	R	jX
700	11.7	-4.5
720	11.0	-4.0
740	10.3	-3.6
760	9.8	-3.1
780	9.3	-2.6
800	8.9	-2.1
820	8.6	-1.6
840	8.3	-1.0
860	8.0	-0.5
880	7.8	0.0
900	7.7	0.6
920	7.6	1.1
940	7.5	1.7
960	7.4	2.3
980	7.4	2.9
1000	7.5	3.5

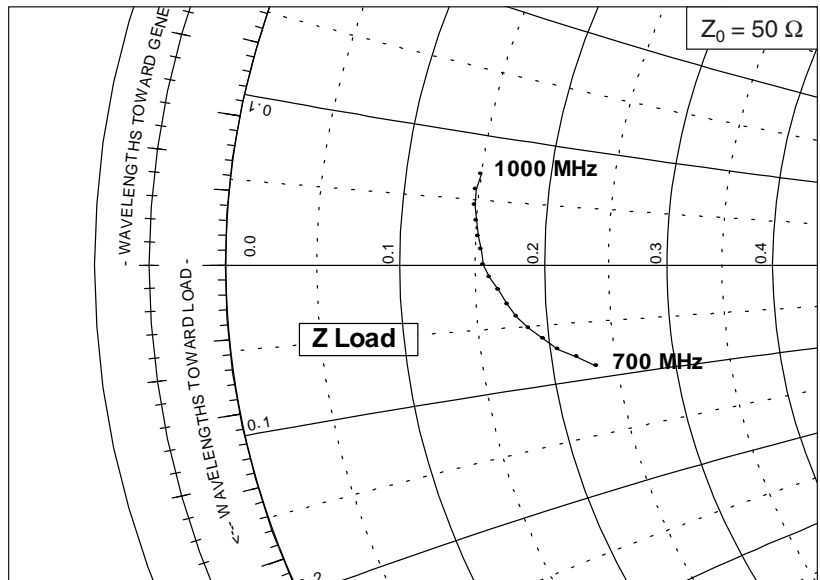
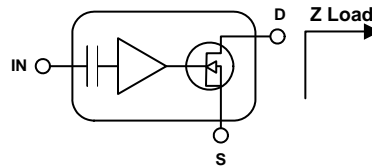

Reference Circuit — for evaluation only

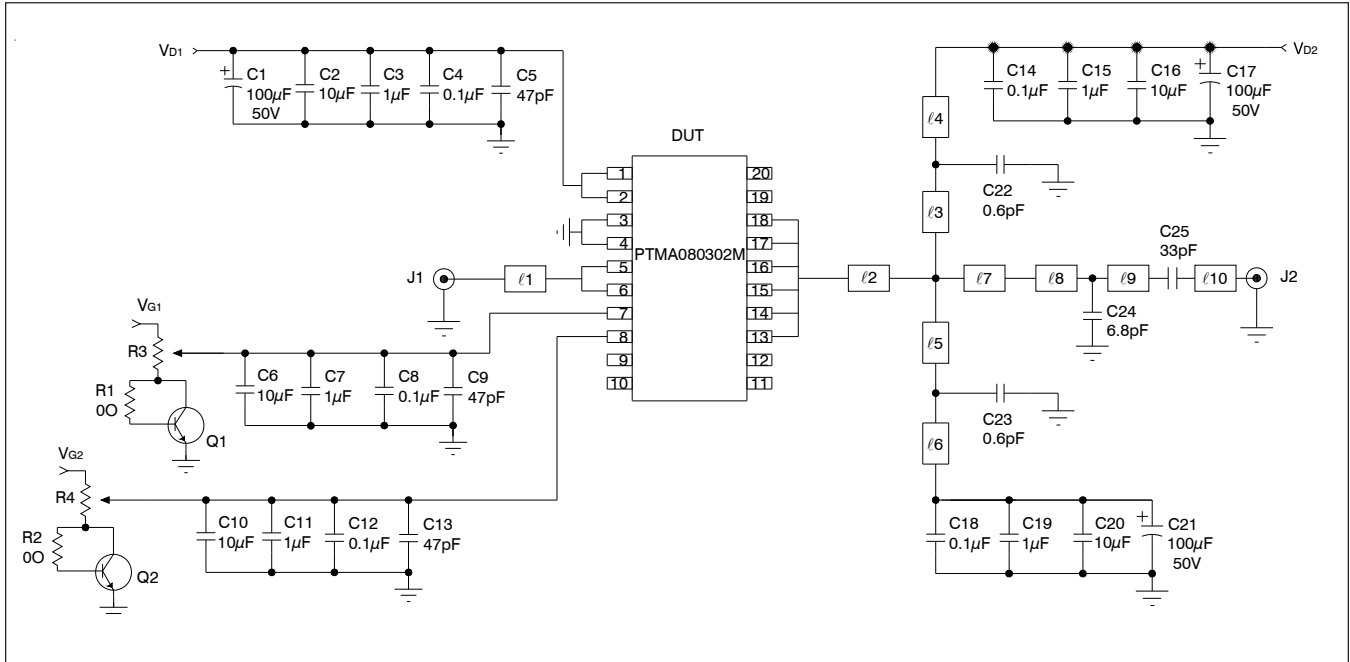

Reference circuit schematic for $f = 940$ MHz

Circuit Assembly Information

DUT	PTMA080302M	LDMOS IC	
PCB	0.76 mm [.030"] thick, $\epsilon_r = 3.48$	Rogers RO4350	1 oz. copper

Microstrip	Electrical Characteristics at 1960 MHz	Dimensions: L x W (mm)	Dimensions: L x W (in.)
$\ell 1$	0.161λ , 50.0Ω	27.76 x 1.70	1.093 x 0.067
$\ell 2$	0.012λ , 10.4Ω	2.01 x 13.00	0.079 x 0.512
$\ell 3$	0.012λ , 10.4Ω	2.06 x 13.00	0.081 x 0.512
$\ell 4$	0.044λ , 34.2Ω	7.52 x 3.00	0.296 x 0.118
$\ell 5$	0.022λ , 34.2Ω	3.81 x 3.00	0.150 x 0.118
$\ell 6$	0.095λ , 43.6Ω	16.43 x 2.11	0.647 x 0.083
$\ell 7, \ell 8$	0.093λ , 50.0Ω	5.03 x 1.70	0.198 x 0.067
$\ell 9$	0.161λ , 47.8Ω	27.79 x 1.83	1.094 x 0.072

Reference Circuit (cont.)

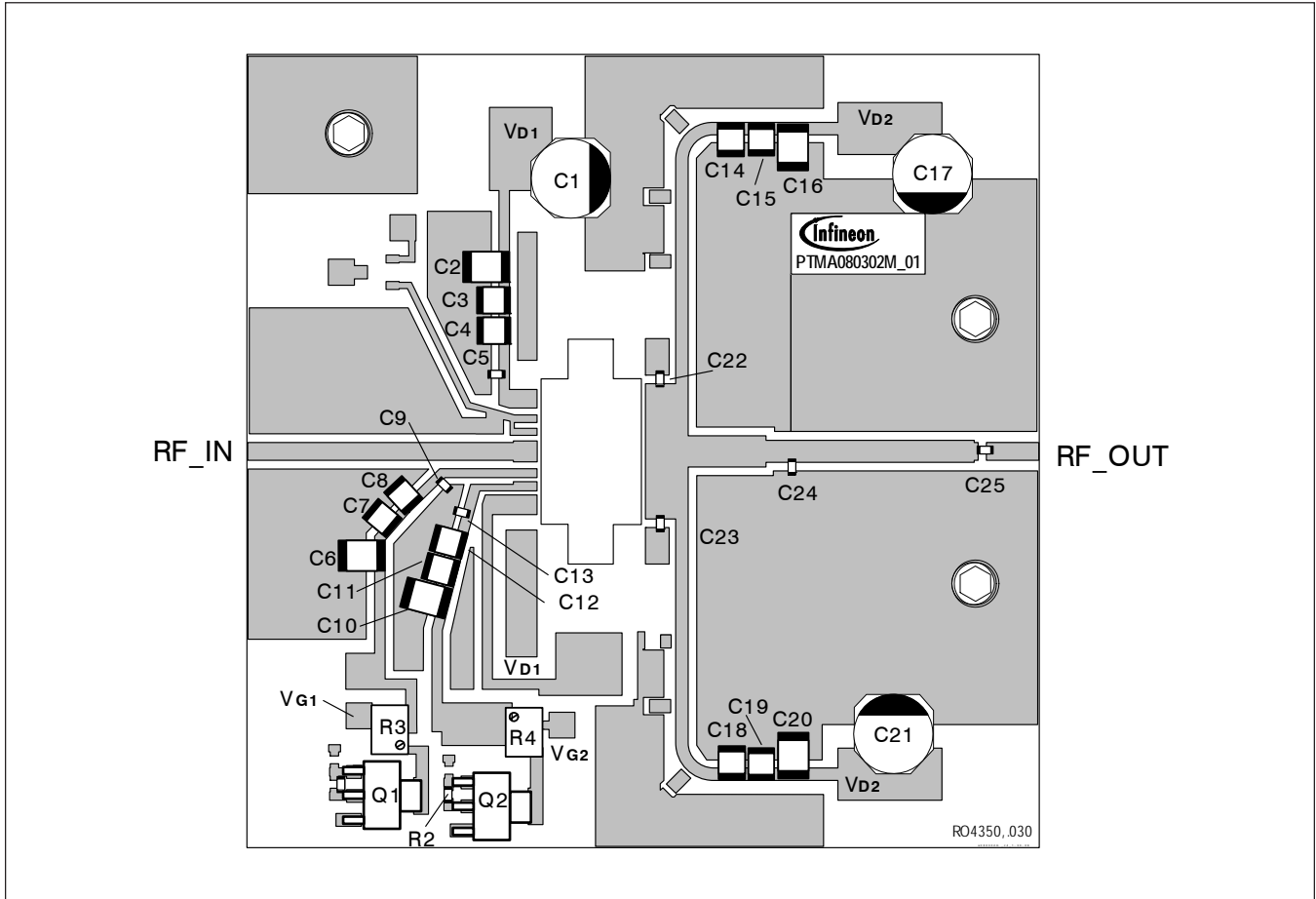

Reference circuit assembly diagram* (not to scale)

Component	Description	Suggested Manufacturer	P/N or Comment
C1, C17, C21	Electrolytic capacitor, 100 μ F, 50 V	Digi-Key	PCE3718CT-ND
C2, C6, C10, C16, C20	Ceramic capacitor, 10 μ F	Murata	GRM422Y5V106Z050AL
C3, C7, C11, C15, C19	Ceramic capacitor, 1 μ F	Digi-Key	445-1411-2-ND
C4, C8, C12, C14, C18	Capacitor, 0.1 μ F	Digi-Key	399-1267-2-ND
C5, C9, C13	Ceramic capacitor, 47 pF	ATC	600F470JT
C22, C23	Ceramic capacitor, 0.6 pF	ATC	600S0R6BT
C24	Ceramic capacitor, 6.8 pF	ATC	600S6R8CT
C25	Ceramic capacitor, 33 pF	ATC	600F330JT
Q1, Q2	Transistor	Infineon Technologies	BCP56
R1, R2	Resistor, 0 Ω	Digi-Key	603
R3, R4	Potentiometer 2k Ω	Digi-Key	3224W-202ETR-ND

Package Outline Specifications

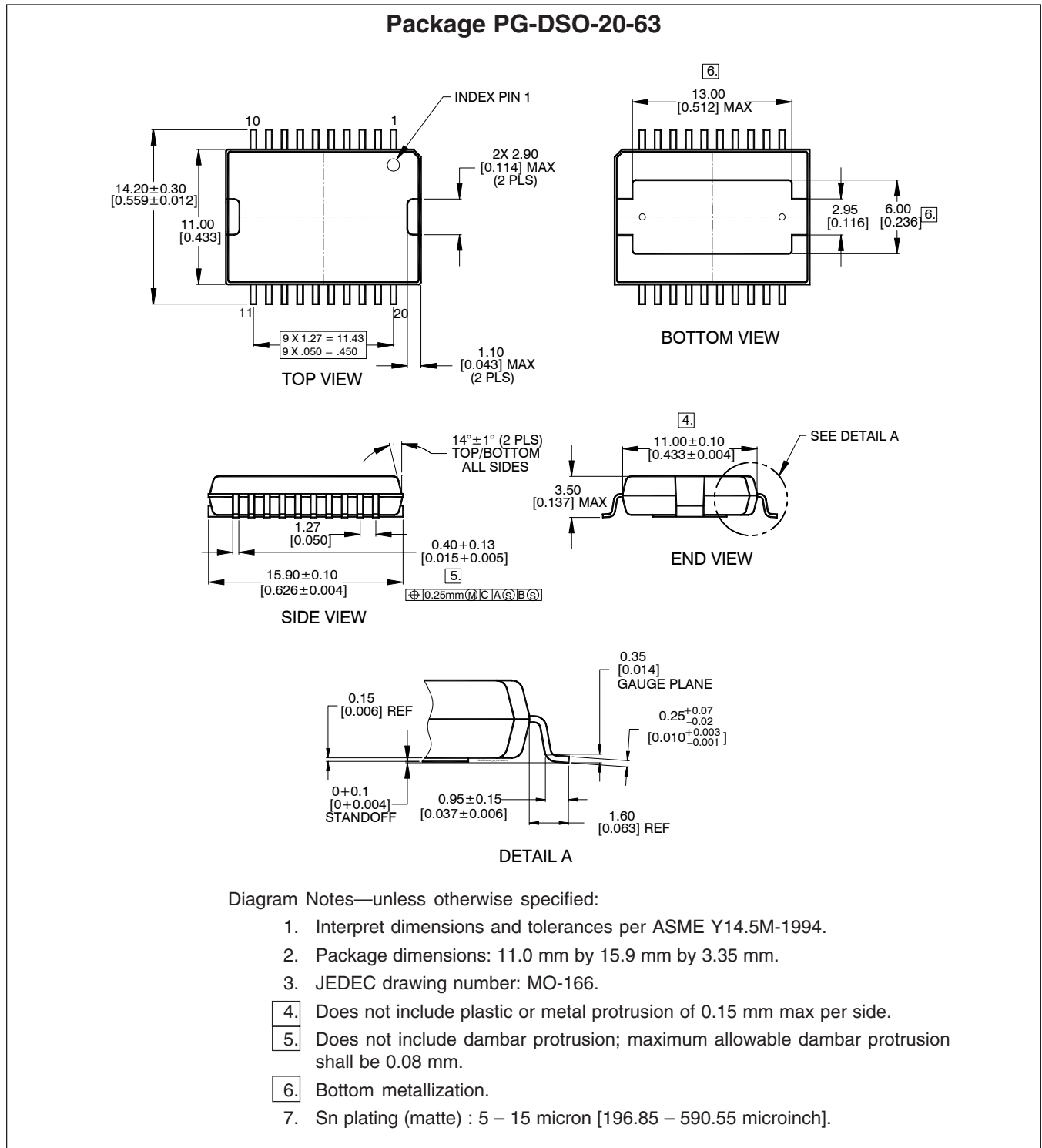

Refer to Application Note "Recommendations for Printed Circuit Board Assembly of Infineon DSO and SSOP Packages" for additional information.

Pinout Diagram

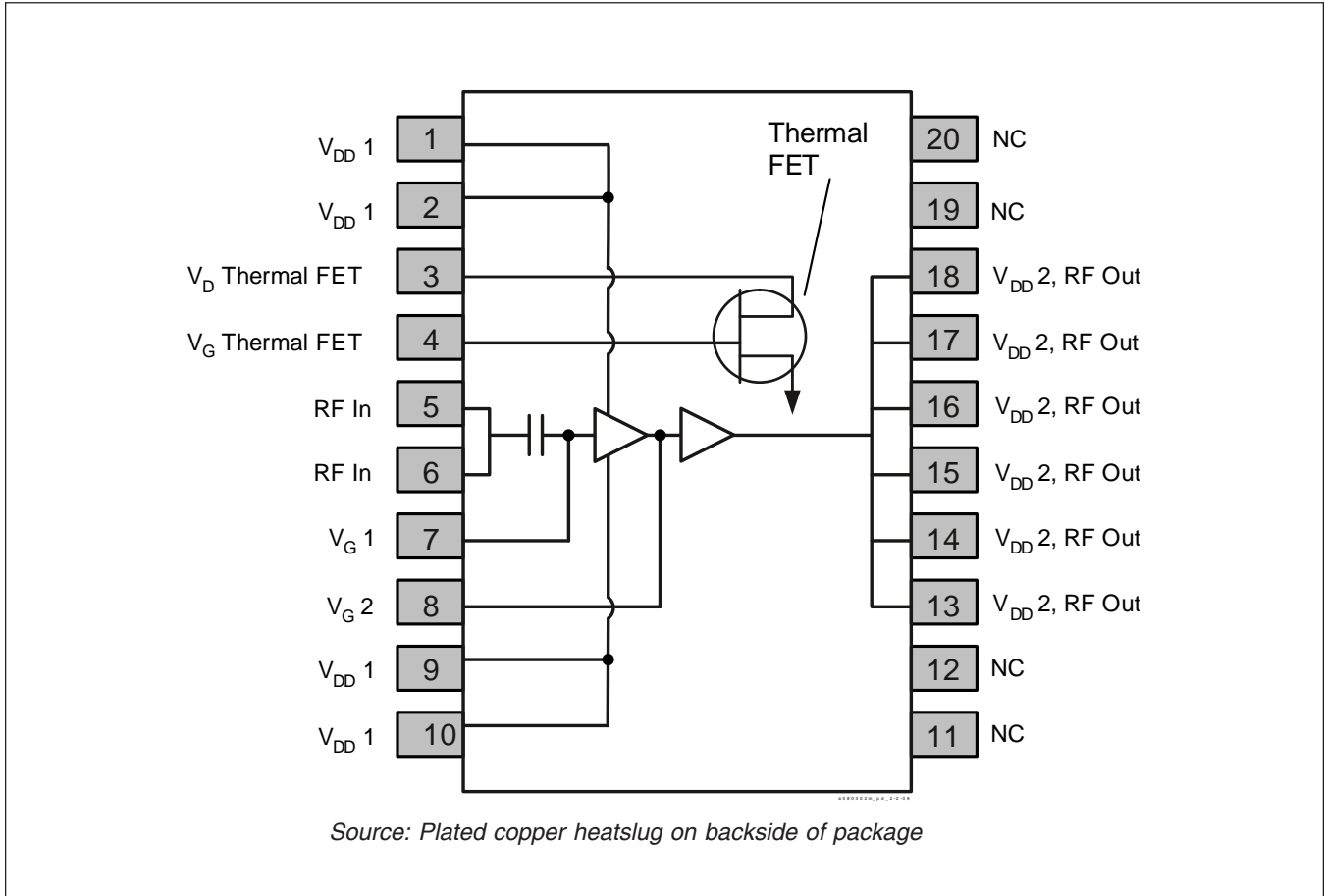

Find the latest and most complete information about products and packaging at the Infineon Internet page <http://www.infineon.com/rfpower>

Revision History: 2010-04-16

Data Sheet

Previous Version: 2009-08-31, Data Sheet

Page	Subjects (major changes since last revision)
3	Added moisture sensitivity level table
9	Updated package outline notes

We Listen to Your Comments

Any information within this document that you feel is wrong, unclear or missing at all?

Your feedback will help us to continuously improve the quality of this document.

Please send your proposal (including a reference to this document) to:

highpowerRF@infineon.com

To request other information, contact us at:

+1 877 465 3667 (1-877-GO-LDMOS) USA

or +1 408 776 0600 International

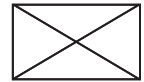

Edition 2010-04-16

Published by

Infineon Technologies AG

81726 Munich, Germany

© 2009 Infineon Technologies AG

All Rights Reserved.

Legal Disclaimer

The information given in this document shall in no event be regarded as a guarantee of conditions or characteristics. With respect to any examples or hints given herein, any typical values stated herein and/or any information regarding the application of the device, Infineon Technologies hereby disclaims any and all warranties and liabilities of any kind, including without limitation, warranties of non-infringement of intellectual property rights of any third party.

Information

For further information on technology, delivery terms and conditions and prices, please contact the nearest Infineon Technologies Office (www.infineon.com/rfpower).

Warnings

Due to technical requirements, components may contain dangerous substances. For information on the types in question, please contact the nearest Infineon Technologies Office.

Infineon Technologies components may be used in life-support devices or systems only with the express written approval of Infineon Technologies, if a failure of such components can reasonably be expected to cause the failure of that life-support device or system or to affect the safety or effectiveness of that device or system. Life support devices or systems are intended to be implanted in the human body or to support and/or maintain and sustain and/or protect human life. If they fail, it is reasonable to assume that the health of the user or other persons may be endangered.