

**F71610**

# **F71610**

---

## **USB CIR Chip for Vista (Receive Only)**

**Release Date: December, 2007**

**Version: V0.22P**

**F71610 Datasheet Revision History**

Version	Date	Page	Revision History
V0.20P	2007/09/06	-	Release Version
V0.21P	2007/11/19	-	Add function (I2C Interface) and modify description of this new function.
		10	Modify Ordering Information ( Part No Change to F71610R from F71610RG)
		12	Modify Application Circuit.
V0.22P	2007/12/17	1	Modify Operating Supply Current

Please note that all data and specifications are subject to change without notice. All the trade marks of products and companies mentioned in this data sheet belong to their respective owners.

**LIFE SUPPORT APPLICATIONS**

These products are not designed for use in life support appliances, devices, or systems where malfunction of these products can reasonably be expected to result in personal injury. Customers using or selling these products for use in such applications do so at their own risk and agree to fully indemnify Fintek for any damages resulting from such improper use or sales.

## Table of Content

---

---

1.	General Description .....	1
2.	Feature List .....	1
3.	Key Specification.....	1
4.	Pin Configuration.....	2
5.	Pin Description.....	2
6.	Function Description.....	4
7.	Electron Characteristic.....	8
8.	Ordering Information.....	10
9.	Package Dimensions .....	11
10.	Application Circuit.....	12

Fintek Confidential  
Do Not Copy!

## 1. General Description

The F71610 is a USB IR chip and completely compatible with Microsoft Windows Vista IR Receiver Emulation Device. It Supports One IR receiver with long range frequency application.

In interface function, the F71610 communications with host by full-speed USB interface (12Mb/s). In power function, The F71610 supports remote-wakeup function for USB interface, when PC system into S3 state. The F71610 decodes IR protocol is the same power key of remote control. The F71610 is asserted USB interface to wakeup PC system. Others, the F71610 supports remote-wakeup function by PSOUT# pin, when PC system in to S5 state, the F71610 is asserted PSOUT# pin to wakeup PC system.

In I2C interface function, The F71610 builds 256 bytes SRAM to save flash/ROM information from I2C for USB bus enumerations. The I2C flash/ROM contains IdVendor/ IdProduct/ BcdDevice/ Manufacturer string / IProduct string / iSerialNumber string information.

This product is packaged in 16 SSOP green package and power by 3.3V.

## 2. Feature List

- Support Microsoft Vista OS IR receiver.
- Support USB remote wake-up capability.
- Hardware base implementation.
- Hardware trigger wake-up event
- Provide data receiver LED.
- One IR receiver with long range frequency application.
- I2C Interface for Related ID Data Reading.
- Power by 3.3V and package in 16SSOP green package

## 3. Key Specification

- |                            |              |
|----------------------------|--------------|
| ● Supply Voltage           | 3.0V to 3.6V |
| ● Operating Supply Current | 8 mA typ.    |
| ● Standby Current          | 0.7 mA typ.  |

# F71610

## 4. Pin Configuration

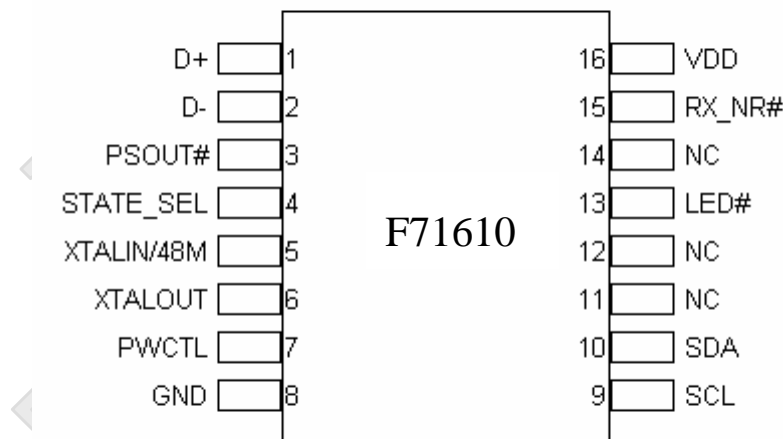

## 5. Pin Description

- I/O<sub>12t\_1.5k</sub> - TTL level bi-directional pin with 12 mA drive/sink capability and internal pull high 1.5kΩ
- I/O<sub>12t</sub> - TTL level bi-directional pin with 12 mA drive/sink capability.
- OD<sub>12</sub> - Open-drain output pin with 12 mA sink capability
- OD<sub>12\_5v</sub> - Open-drain output pin with 12 mA sink capability and 5V tolerance
- OD<sub>16\_5v</sub> - Open-drain output pin with 16 mA sink capability and 5V tolerance.
- O<sub>12</sub> - Output pin with 12 mA drive/sink capability.
- IN<sub>ts</sub> - TTL level input pin with schmitt trigger.
- IN<sub>ts\_5v</sub> - TTL level input pin with schmitt trigger and 5V input tolerance.
- IN<sub>t</sub> - TTL level input pin.
- P - Power.

# F71610

Pin No	Pin Name	Type	PWR	Description
1	D+	I/O <sub>12t_1.5k</sub>	VDD	D+. Different data bus conforming to USB standard. Internal pull high 1.5kΩ.
2	D-	I/O <sub>12t</sub>	VDD	D-. Different data bus conforming to USB standard.
3	PSOUT#	OD <sub>12_5v</sub>	VDD	Panel Switch Output. This pin is low active and pulse output. It is power on request output.
4	STATE_SEL	IN <sub>ts</sub>	VDD	<p>This pin is for wake up function.</p> <p><b>For Device Product</b> → Pull this pin to high for USB wake up.</p> <p><b>For MB System Product</b> → Pull this pin to high and suggest connecting pin with one of PWROK/GPIO pin.</p> <p>MB System in S5 state: Wake up signal will be asserted by PSOUT# pin in S5 state.</p> <p>MB System in S3 state: Wake up signal will be asserted by USB interface in S3 state.</p>
5	XTALIN/48M	IN <sub>t</sub>	VDD	12MHz/48MHz clock input.
6	XTALOUT	O <sub>12</sub>	VDD	12MHz/48MHz clock output.
7	PWCTL	OD <sub>12</sub>	VDD	RX_LR learning power control pin. Suggest external pull high to 3.3V and the clock input source will be selected to 12MHz input.
8	GND	P	VDD	Ground pin.
9	SCL (SCK)	OD <sub>12_5v</sub>	VDD	I2C interface serial clock
10	SDA	OD <sub>12_5v</sub>	VDD	I2C interface serial data
11-12	NC	-	-	NC pins
13	LED#	OD <sub>16_5v</sub>	VDD	LED output pin.
14	NC	-	-	NC pin. Please pull high 10k resistor to VDD.
15	RX_NR#	IN <sub>ts_5v</sub>	VDD	IR receiver port (long range)
16	VDD	P	VDD	Power supply input VDD (3.3V)

## 6. Function Description

### 6.1 USB function

The F71610 communications with host by full-speed USB interface (12Mb/s). It supports 3 suits endpoint, one control endpoint( endpoint zero) is for bus enumeration, one output endpoint is for Microsoft Windows Vista IR Receiver Emulation Device command and one input endpoint is transmit IR information to host.

Endpoint zero is special significance in USB system. It is a control endpoint, and is required by every device. Only control endpoint accept special setup token that the host transfer command to device.

During enumeration, host requests GET\_DESCRIPTOR to device and device return information (over in endpoint zero) as what device driver top load. The below table is about F71610 descriptor.

offset	Field	size	Value
0	BLength	1	0x12
1	bDescriptor Type	1	0x01
2	BcdUSB	2	0x0200
4	bDeviceClass	1	0x00
5	bDeviceSubClass	1	0x00
6	bDeviceProtocol	1	0x00
7	bMaxPacketSize	1	0x10
8	IdVendor	2	0x1934
10	IdProduct	2	0x0602
12	BcdDevice	2	0x0000
14	Manufacturer	1	0x01
15	lProduct	1	0x02
16	iSerialNumber	1	0x03
17	bNumConfiguration	1	0x01

Table 6-1 Device Descriptor

offset	Field	size	Value
0	BLength	1	0x09
1	bDescriptor Type	1	0x02
2	wTotalLength	2	0x0020
4	bNumInterface	1	0x01
5	bConfigurationValue	1	0x01
6	iConfiguration	1	0x00
7	BmAttributes	1	0xa0
8	MaxPower	1	0x32

Table 6-2 Configuration Descriptor

offset	Field	size	Value
--------	-------	------	-------

# F71610

0	BLength	1	0x09
1	bDescriptor Type	1	0x04
2	wInterfaceNumber	1	0x00
3	bAlternateSetting	1	0x00
4	bNumEndpoints	1	0x02
5	bInterfaceClass	1	0xff
6	bInterfaceSubClass	1	0xff
7	bInterfaceProtocol	1	0xff
8	IInterface	1	0x00

Table 6-3 Interface Descriptor

offset	Field	size	Value
0	BLength	1	0x07
1	bDescriptor Type	1	0x05
2	bEndpointAddress	1	0x81
3	BmAttributes	1	0x02
4	wMaxPacketSize	2	0x0010
6	BInterval	1	0x00

Table 6-4 In Endpoint Descriptor

offset	Field	size	Value
0	BLength	1	0x07
1	bDescriptor Type	1	0x05
2	bEndpointAddress	1	0x01
3	BmAttributes	1	0x02
4	wMaxPacketSize	2	0x0010
6	BInterval	1	0x00

Table 6-5 Out Endpoint Descriptor

The string table 1 is about manufacturer information, its' contents is "FINTEK", the string table 2 is about Product information, its contents is "eHome Infrared Transceiver. The string table 3 is about serial number information, its contents is "88636562727801".

In power function, The F71610 supports remote-wakeup function for USB interface, when PC system into S3 state. The F71610 decodes IR protocol is the same power key of remote control. The F71610 is asserted USB interface to wakeup PC system.

The F71610 is compatible for Microsoft Windows Vista IR Receiver Emulation Device. The F71610 support Microsoft Compatible Device Descriptor and Extended Compact ID Descriptor are used to tell the host what type of device the emulation is. Vista Emulation Device driver transmits command over out endpoint1 and device return information over in endpoint1. About descriptor and command information, reference Microsoft Windows Vista IR Receiver Emulation Device spec.

## 6.2 IR function



## F71610

The F71610 supports One IR receiver with long range frequency application. The long-range receiver is a receiver which has the following characteristics:

1. Works at a distance of 10 meters.
2. Demodulates the signal inside the receiver part
3. Has a BPF which works with carriers from 32-60 kHz.

About IR information, reference Microsoft Windows Vista IR Receiver Emulation Device spec.

### 6.3 Wakeup function

The F71610 Supports 2 kinds of wakeup system function, PSOUT and remote wakeup for USB interface. The F71610 detect idle state on USB bus for more than 3.0ms, it is into suspend state.

In Suspend state, the F71610 decodes IR protocol information is the same power key of remote controller. It asserted PSOUT and USB interface. Reference the below figure

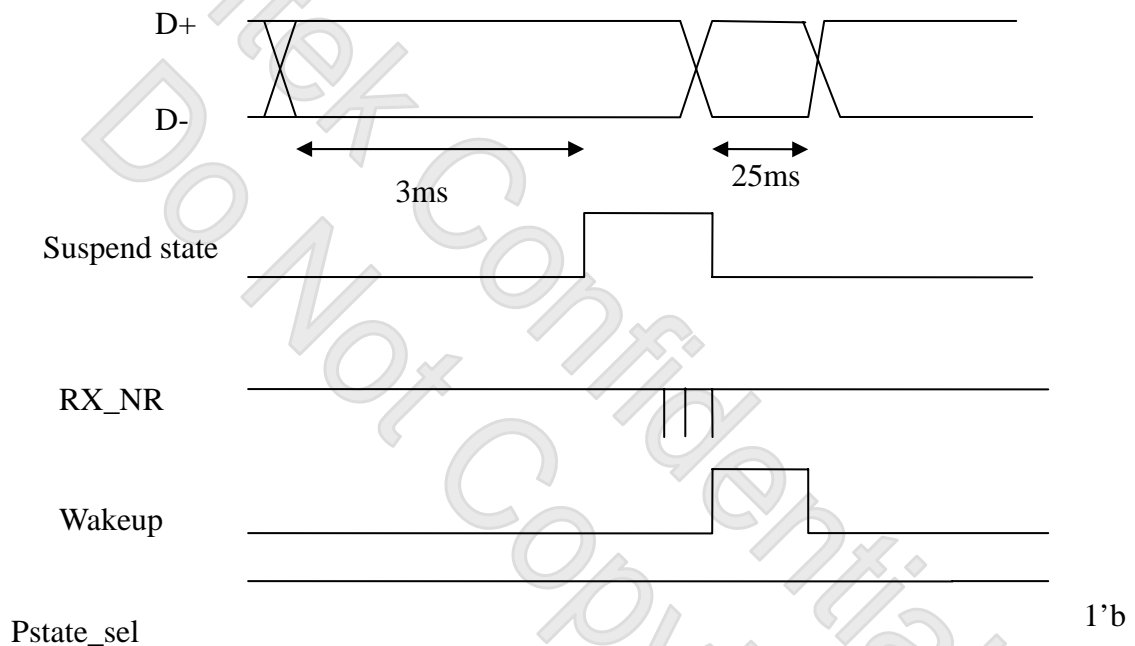

Figure 6-3-1 USB remote wakeup

# F71610

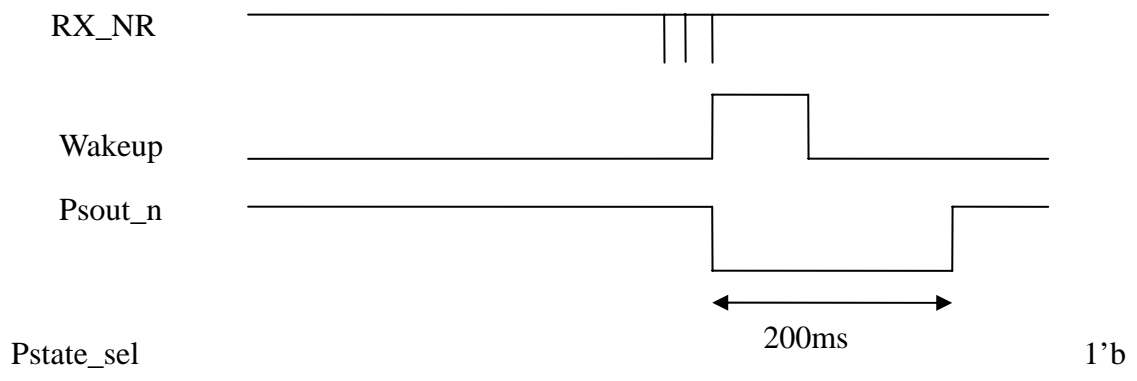

Figure 6-3-2 PSOUT wakeup

## 6.4 I2C interface function

The F71610 Supports 1 suit I2C interface to get USB description information and builds 256 bytes RAM to save vendor USB description information. When power is ready, I2C function start to load USB description into 256 bytes RAM, and expect host requests GET\_DESCRIPTOR to F71610 which returns vendor USB description, if i2c flash/ROM connect with F71610. The contents of I2C flash /ROM format is below table.

When F71610 does not finish loading 256 bytes information from I2C flash/ROM, F71610 disable PAD 1 internal pull high 1.5k, still finish loading, F71610 enable PAD 1 internal pull high 1.5k.

0x0	Security code	0x55
0x1	Security code	0xaa
0x2	IdVendor length	0x02
0x3	IdVendor low byte	IdVendor low byte
0x4	IdVendor low byte	IdVendor high byte
0x5	IdProduct length	0x02
0x6	IdProduct low byte	IdProduct low byte
0x7	IdProduct high byte	IdProduct high byte
0x8	BcdDevice length	0x02
0x9	BcdDevice low byte	BcdDevice low byte
0xa	BcdDevice high byte	BcdDevice high byte
0xb	Manufacturer string length	Define by vendor content
0xb+ Manufacturer string length	Manufacturer string content	Define by vendor content
0xb+ Manufacturer string length + 1	IPProduct string length	Define by vendor content

## F71610

0xb+ Manufacturer string length +1 IProduct string length +1	IProduct string content	Define by vendor content
0xb+ Manufacturer string length +2 IProduct string length +2	ISerialNumber string length	Define by vendor content
0xb+ Manufacturer string length +2 IProduct string length +2	IProduct string length	Define by vendor content

Table 6-4-1 I2C flash/ROM USB description format

## 7. Electron Characteristic

### Absolute Maximum Ratings

PARAMETER	RATING	UNIT
Power Supply Voltage	-0.5 to 5	V
Input Voltage	-0.5 to VDD+0.5	V
Operating Temperature	0 to +70	° C
Storage Temperature	-55 to 150	° C

Electrical characteristics table

Note: Exposure to conditions beyond those listed under Absolute Maximum Ratings may adversely affect the life and reliability of the device.

### DC Characteristics

(Ta = 0° C to 70° C, VDD = 3.3V ± 10% , VSS = 0V ) (Note)

PARAMETER	RATING	UNIT
Operating Voltage	3.0 to 3.6	VDD

Operating Voltage table

PARAMETER	SYM.	MIN	TYP	MAX.	UNIT	CONDITIONS
<b>I/O<sub>12t</sub> - TTL level bi-directional pin with 12 mA source-sink capability(3.3V)</b>						
Input Low Voltage	VIL			0.8	V	
Input High Voltage	VIH	2.0			V	
Output Low Current	IOL		12		mA	0.4V
Output High Current	IOH		12		mA	2.4V
Input High Leakage	ILIH	-1		1	μA	
Input Low Leakage	ILIL	-1		1	μA	
<b>OD<sub>12_5v</sub> – Open-drain output pin with 12mA source-sink capability(3.3V), 5V tolerance</b>						
Output Low Current	IOL		12		mA	0.4V
<b>OD<sub>16_5v</sub> – Open-drain output pin with 16mA source-sink capability(3.3V), 5V tolerance</b>						

# F71610

Output Low Current	IOL		16		mA	0.4V
<b>O<sub>12</sub> – Output pin with 12mA source-sink capability(3.3V)</b>						
Output Low Current	IOL		12		mA	0.4V
Output HIGH Current	IOH		12		mA	2.0V
<b>IN<sub>ts</sub> – TTL level input pin and schmitt trigger</b>						
Input Low Threshold Voltage	Vt-			0.8	V	
Input High Threshold Voltage	Vt+	2.0			V	
Hysteresis			0.5		V	
Input High Leakage	ILIH			+1	μA	
Input Low Leakage	ILIL	-1			μA	
<b>IN<sub>t</sub> – TTL level input pin</b>						
Input Low Threshold Voltage	Vt-			0.8	V	
Input High Threshold Voltage	Vt+	2.0			V	
Input High Leakage	ILIH			+1	μA	
Input Low Leakage	ILIL	-1			μA	
<b>IN<sub>ts_5v</sub> – TTL level input pin and schmitt trigger, 5 tolerance</b>						
Input Low Threshold Voltage	Vt-			0.8	V	
Input High Threshold Voltage	Vt+	2.0			V	
Hysteresis			0.5		V	
Input High Leakage	ILIH			+1	μA	
Input Low Leakage	ILIL	-1			μA	

PAD DC table

## USB Interface

Parameter	Symbol	Min.	Max.	Units
Rise Time	T <sub>FR</sub>	4	20	ns
Fall Time	T <sub>FF</sub>	4	20	ns
Differential Rise and Fall Time Matching	T <sub>FRFM</sub>	90	111.11	%
Driver Output Resistance	Z <sub>DRV</sub>	28	44	Ω

USB AC

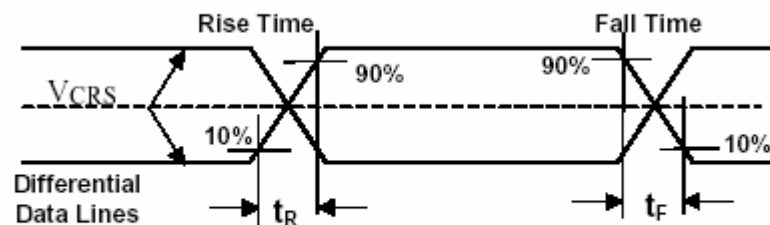

1

USB timing

Jitter Source	Full-speed			
	Next Transition		Paired Transition	
	Each (ns)	Total (ns)	Each (ns)	Total (ns)

## F71610

<b>Source Driver Jitter</b>	2.0	2.0	1.0	1.0
Source Frequency Tolerance (worst-case)	0.21/bit	1.5	0.21/bit	3.0
<b>Source Jitter Total</b>		3.5		4.0
Hub Jitter	3.0	15.0	1.0	5.0
<b>Jitter Specification</b>		18.5		9.0
Destination Frequency Tolerance	0.21/bit	1.5	0.21/bit	3.0
<b>Receiver Jitter Budget</b>		20.0		12.0

USB Jitter

## 8. Ordering Information

Part Number	Package Type	Production Flow
F71610R	16-SSOP Green Package	Commercial, 0°C to +70°C

# F71610

## 9. Package Dimensions

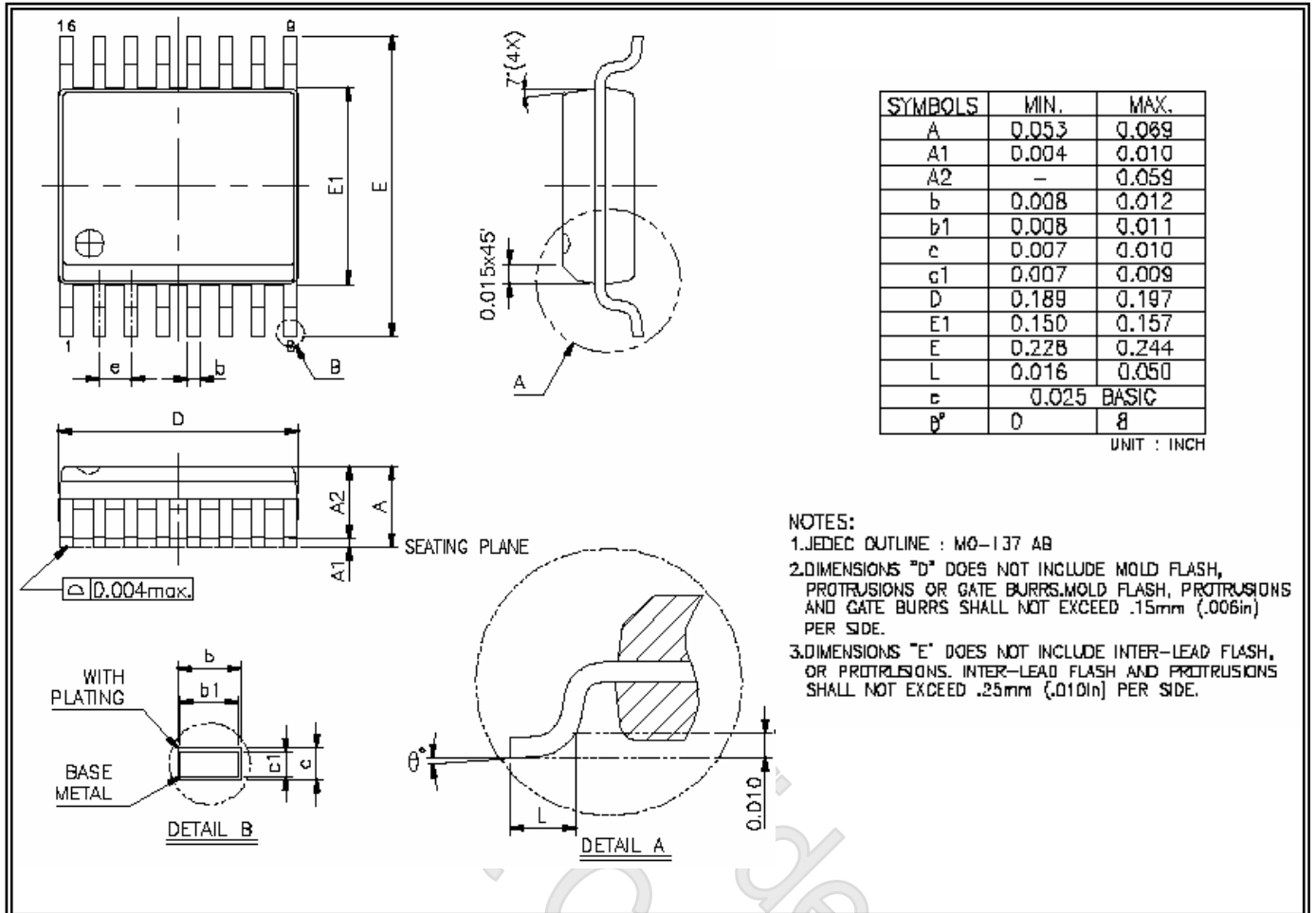
**16pin-SSOP ( 150 mil)**

**Headquarters**

3F-7, No 36, Tai Yuan St.,

Chupei City, Hsinchu, Taiwan 302, R.O.C.

TEL : 886-3-5600168

FAX : 886-3-5600166

 www: <http://www.fintek.com.tw>
**Taipei Office**

Bldg. K4, 7F, No.700, Chung Cheng Rd.,

Chungho City, Taipei, Taiwan 235, R.O.C.

TEL : 866-2-8227-8027

FAX : 866-2-8227-8037

Please note that all datasheet and specifications are subject to change without notice. All the trade marks of products and companies mentioned in this datasheet belong to their respective

# F71610

## 10. Application Circuit

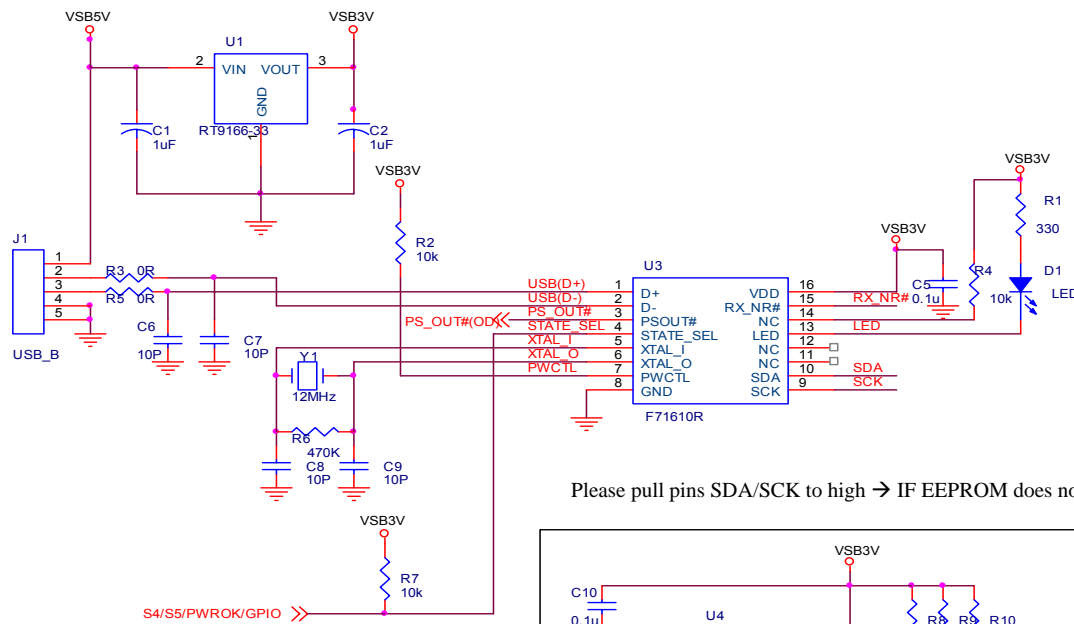

Please pull pins SDA/SCK to high → IF EEPROM does not be used.

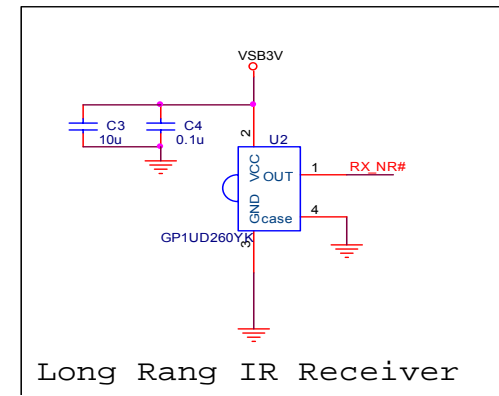
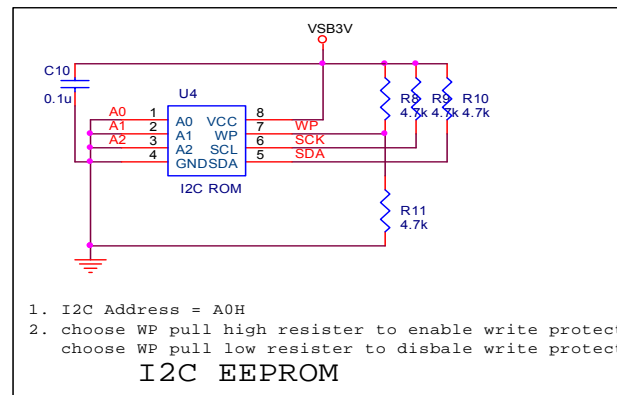

Title		
FINTEK F71610R application circuit		
Size	Document Number	Rev
B	<Doc>	1.0
Date:	Thursday, November 22, 2007	Sheet 1 of 1