



GG-1570-20

The GG-1570-20 power converter / Backup Battery is a nominal 13.8 volt to 13.8 volt dc—dc converter With a backup battery to supply power during starting etc. This device is designed for use on trains, buses, trucks, or other automotive devices where clean regulated electrical power is required.

The input of the converter is protected against polarity connections. The converter is also protected against thermal and over voltage input with automatic recovery.

The converter protects against transient up to 300 volts with an energy content of up to 10 joules.

The converter can handle vibration and shock as is normally encountered in the automotive environment and storage temperatures of 85°C.

The Battery backup can provide provide 2 amps for up to 12 minutes and of course lower currents for longer periods. The curve on page 2 shows the battery output voltage for current drains of 1.5 and 2.0 amps.

A logic signal is available in the event of a power loss.

This UPS is packaged in a small, metal enclosure for maintenance free operation.

Performance Specifications:

- Input Voltage range = 10.6—16.2 VDC
- Output Voltage = 13.8 VDC
- Power output = 300 Watts continuous @13.8 VDC
- Ripple < 1% of output
- Regulation = +/- 2% Line/Load
- DC Isolation (Input/Output, Input/ Chassis, Output Chassis) = 1000 VDC
- Efficiency = 87%
- Short circuit protection = automatic recovery
- Reverse polarity protected input
- 2 fused outputs
- Battery backup output = 12 Volt
- Battery backup engage voltage = 10.6 volt
- Battery backup dis-engage voltage = 11 volt
- Backup battery shut down time = 6.0 minutes
- Capacity = 1.2 amp-Hr
- Rapid discharge = 2.4 amp for 6 minutes
- Recharge time = 1 hour from full functional discharge to 95 % of full charge.
- Battery replacement life = 6-7 years

Physical Specifications:

- Size: _____ 7.0 x 9.0 x 4.5h
- Finish: _____ Black enamel (baked)
- Mounting: _____ Bracket
- Net weight: _____ **TBD**
- Marking: _____ White permanent ink
- Orbital Logo: _____ Red paint (MS 485)

Environmental Specifications:

- Operating Temp.: -40 to 50°C²
- Storage temp: _____ -40 to 85°C
- Sealing: _____ Splash proof and Dust proof
- Humidity: _____ 0 to 95% non condensing
- Shock: _____ Mil-Std-810, Procedure I, functional shock for ground vehicles.
- Vibration; _____ Mil-Std-810, Category 8 for Equipment installed in wheeled vehicles.

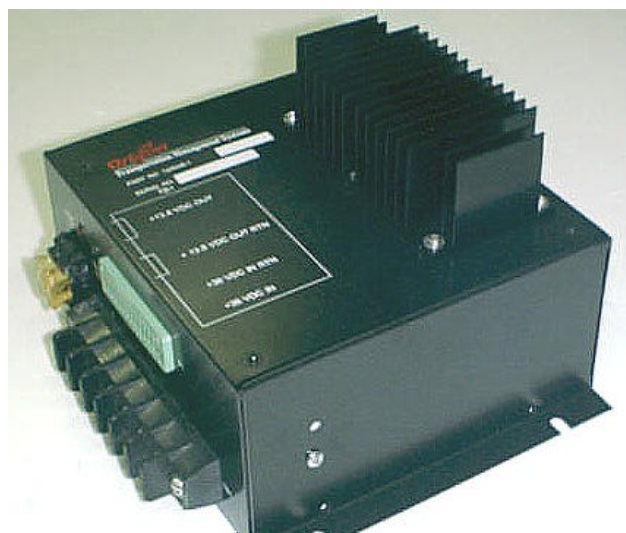

Note: Picture for ref only; shows 7.0 " width rather than 9.0".



GG-1570-20

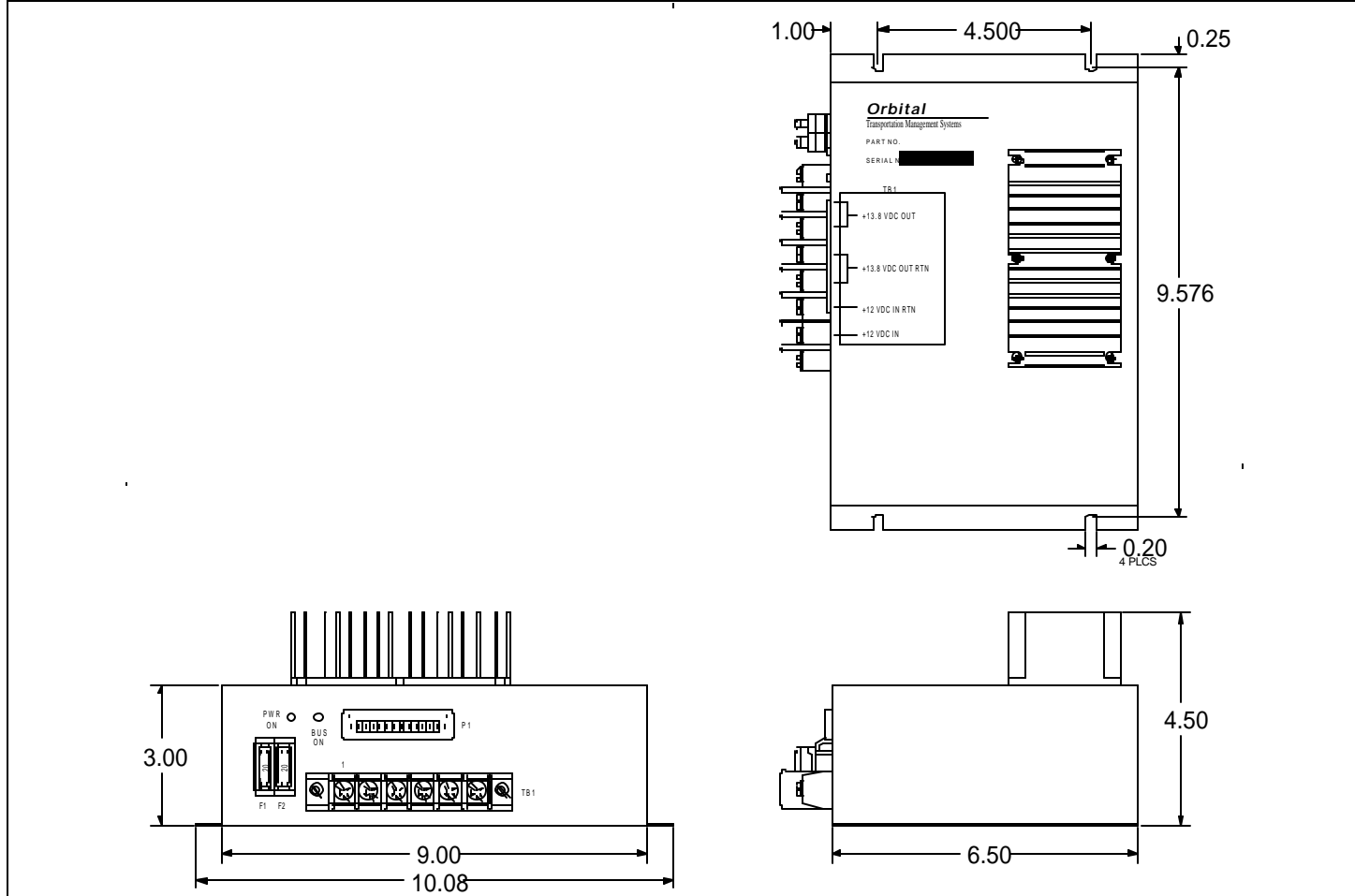

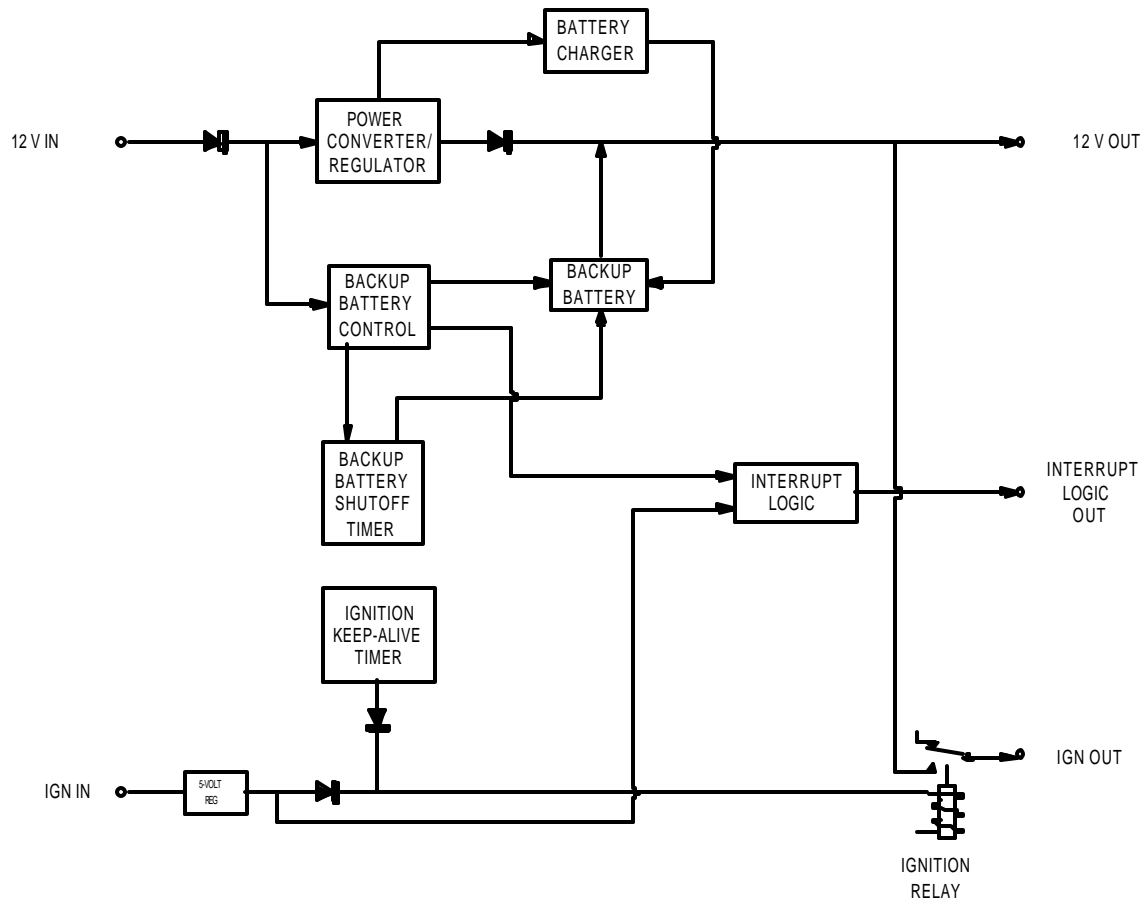

NOTES:

Backup Battery Control: Monitors the input voltage and sends a signal to activate the backup battery if the input voltage falls below 10.6 V.

Backup Battery Shutoff Timer: Disconnects the backup battery after 6 minutes.

Ignition "Keep-Alive" Timer: Forces the "IGN OUT" signal to remain high for at least 8 minutes.

Interrupt Logic: Sets interrupt logic signal "High" if any of the following occurs.

- "12 v in" power is lost.
- "12 v in" power drops below 10.6 v.
- Driver turns off ignition.



GG-1570-20

BATTERY VOLTAGE vs TIME
FOR SPECIFIED
DISCHARGE CURRENT

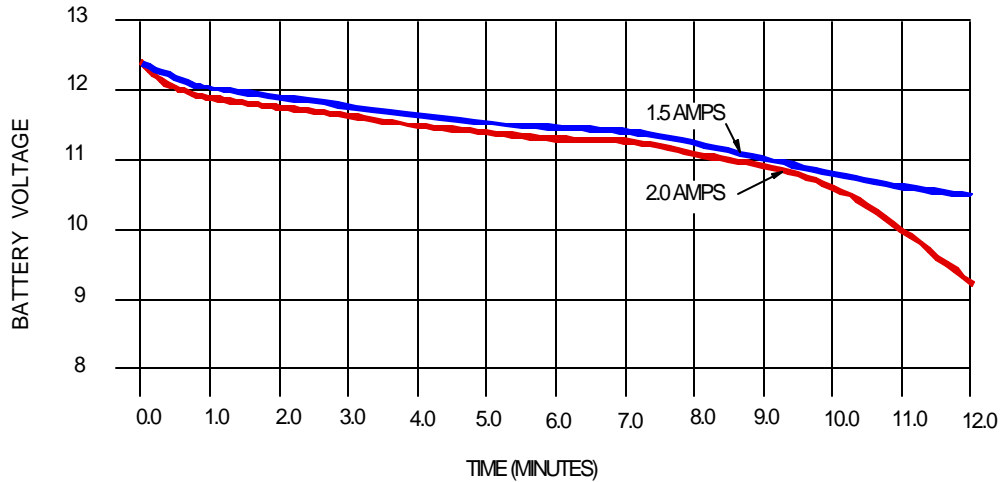

TIMING DIAGRAM

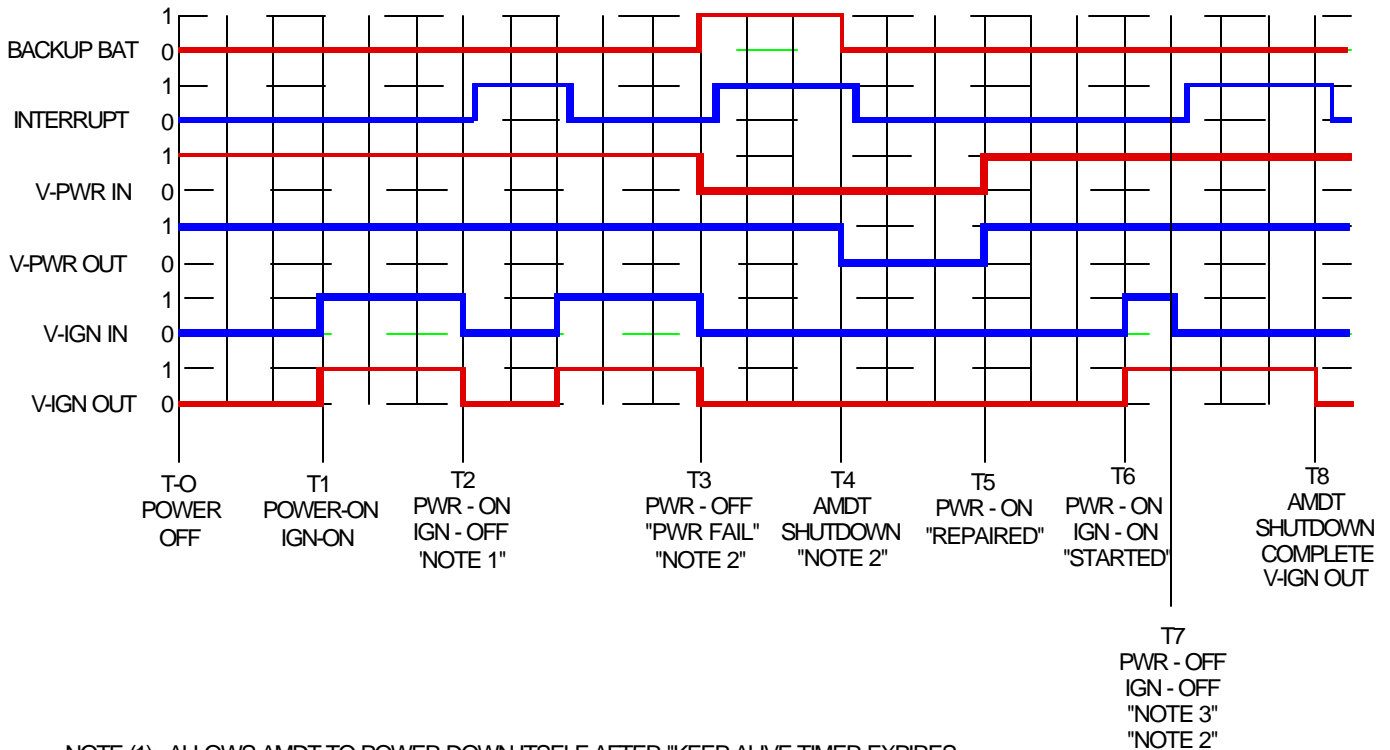

NOTE (1): ALLOWS AMDT TO POWER DOWN ITSELF AFTER "KEEP ALIVE TIMER EXPIRES."
 NOTE (2): UPS TIME FOR SHUTDOWN = (6 MINUTES)
 NOTE (3): IF IGNITION IS TURNED ON THEN OFF (T < 6MIN.), IGNITION STAYS HIGH AND INTERRUPT ACTIVATED.