



ST202E ST232E

± 15KV ESD PROTECTED 5V RS-232 TRANSCEIVER

- ESD PROTECTION FOR RS-232 I/O PINS:
± 15KV HUMAN BODY MODEL
- GUARANTEED 230Kbps DATA RATE
- GUARANTEED SLEW RATE RANGE 3 to 30V/μs
- OPERATE FROM A SINGLE 5V POWER SUPPLY

DESCRIPTION

The ST202E/ST232E are a 2 driver 2 receiver devices designed for RS-232 and V.28 communications in harsh environments. Each transmitter output and receiver input is protected against ± 15KV electrostatic discharge (ESD) shocks. The drivers meet all EIA/TIA-232E and CCITT V.28 specifications at data rates up to 230Kbps, when loaded in accordance with the EIA/TIA-232E specification. The ST202E/232E use a single 5V supply voltage.

The ST232E operates with four 1μF capacitors, while the ST202E operates with four 0.1μF capacitors, further reducing cost and board space.

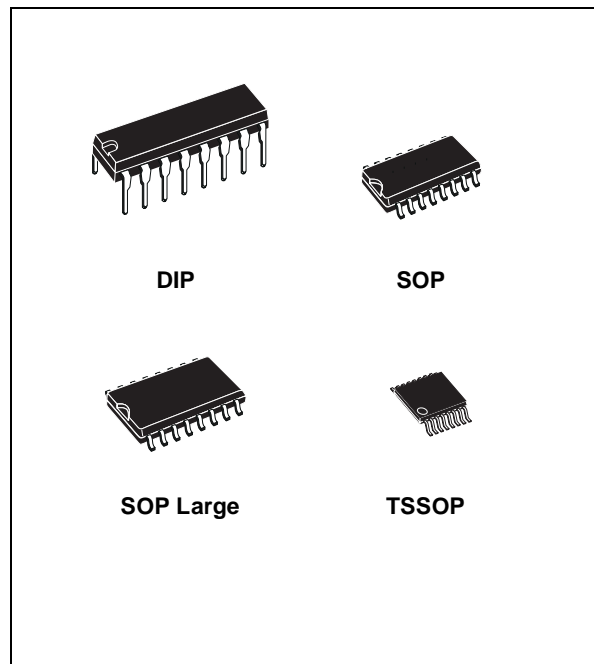

ORDERING CODES

Type		Temperature Range	Package	Comments
ST202ECN	ST232ECN	0 to 70 °C	DIP-16	25 parts per tube / 40 tube per box
ST202EBN	ST232EBN	-40 to 85 °C	DIP-16	25 parts per tube / 40 tube per box
ST202EAN	ST232EAN	-40 to 125 °C	DIP-16	25 parts per tube / 40 tube per box
ST202ECD	ST232ECD	0 to 70 °C	SO-16 (Tube)	50 parts per tube / 20 tube per box
ST202EBD	ST232EBD	-40 to 85 °C	SO-16 (Tube)	50 parts per tube / 20 tube per box
ST202EAD	ST232EAD	-40 to 125 °C	SO-16 (Tube)	50 parts per tube / 20 tube per box
ST202ECDR	ST232ECDR	0 to 70 °C	SO-16 (Tape & Reel)	2500 parts per reel
ST202EBDR	ST232EBDR	-40 to 85 °C	SO-16 (Tape & Reel)	2500 parts per reel
ST202EADR	ST232EADR	-40 to 125 °C	SO-16 (Tape & Reel)	2500 parts per reel
ST202ECW	ST232ECW	0 to 70 °C	SO-16 Large (Tube)	49 parts per tube / 25 tube per box
ST202EBW	ST232EBW	-40 to 85 °C	SO-16 Large (Tube)	49 parts per tube / 25 tube per box
ST202EAW	ST232EAW	-40 to 125 °C	SO-16 Large (Tube)	49 parts per tube / 25 tube per box
ST202ECWR	ST232ECWR	0 to 70 °C	SO-16 Large (Tape & Reel)	1000 parts per reel
ST202EBWR	ST232EBWR	-40 to 85 °C	SO-16 Large (Tape & Reel)	1000 parts per reel
ST202EAWR	ST232EAWR	-40 to 125 °C	SO-16 Large (Tape & Reel)	1000 parts per reel
ST202ECTR	ST232ECTR	0 to 70 °C	TSSOP16 (Tape & Reel)	2500 parts per reel
ST202EBTR	ST232EBTR	-40 to 85 °C	TSSOP16 (Tape & Reel)	2500 parts per reel
ST202EBTR	ST232EBTR	-40 to 125 °C	TSSOP16 (Tape & Reel)	2500 parts per reel

PIN CONFIGURATION

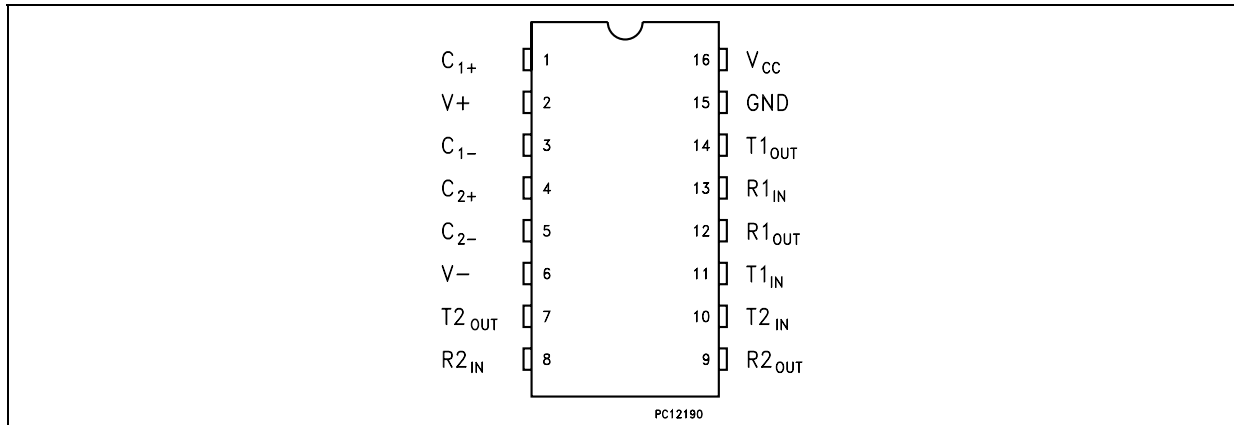

PIN DESCRIPTION

PIN N°	SYMBOL	NAME AND FUNCTION
1	C ₁₊	Positive Terminal for the first Charge Pump Capacitor
2	V+	Doubled Voltage Terminal
3	C ₁₋	Negative Terminal for the first Charge Pump Capacitor
4	C ₂₊	Positive Terminal for the second Charge Pump Capacitor
5	C ₂₋	Negative Terminal for the second Charge Pump Capacitor
6	V-	Inverted Voltage Terminal
7	T2 _{OUT}	Second Transmitter Output Voltage
8	R2 _{IN}	Second Receiver Input Voltage
9	R2 _{OUT}	Second Receiver Output Voltage
10	T2 _{IN}	Second Transmitter Input Voltage
11	T1 _{IN}	First Transmitter Input Voltage
12	R1 _{OUT}	First Receiver Output Voltage
13	R1 _{IN}	First Receiver Input Voltage
14	T1 _{OUT}	First Transmitter Output Voltage
15	GND	Ground
16	V _{CC}	Supply Voltage

ABSOLUTE MAXIMUM RATINGS

Symbol	Parameter	Value	Unit
V _{CC}	Supply Voltage	-0.3 to 6	V
V+	Extra Positive Voltage	(V _{CC} - 0.3) to 14	V
V-	Extra Negative Voltage	-14 to 0.3	V
T _{IN}	Transmitter Input Voltage Range	-0.3 to (V ₊ + 0.3)	V
R _{IN}	Receiver Input Voltage Range	± 30	V
T _{OUT}	Transmitter Output Voltage Range	(V ₋ - 0.3) to (V ₊ + 0.3)	V
R _{OUT}	Receiver Output Voltage Range	-0.3 to (V _{CC} + 0.3)	V
T _{SCTOUT}	Short Circuit Duration on T _{OUT}	infinite	
T _{stg}	Storage Temperature Range	-65 to +150	°C

Absolute Maximum Ratings are those values beyond which damage to the device may occur. Functional operation under these condition is not implied.

ELECTRICAL CHARACTERISTICS

($C_1 - C_4 = 0.1\mu\text{F}$ for ST202E, $C_1 - C_4 = 1\mu\text{F}$ for ST232E, $V_{CC} = 5V \pm 10\%$, $T_A = -40$ to 85°C , unless otherwise specified. Typical values are referred to $T_A = 25^\circ\text{C}$)

Symbol	Parameter	Test Conditions	Min.	Typ.	Max.	Unit
I_{SUPPLY}	V_{CC} Power Supply Current	No Load, $T_A = 25^\circ\text{C}$		5	10	mA

TRANSMITTER ELECTRICAL CHARACTERISTICS

($C_1 - C_4 = 0.1\mu\text{F}$ for ST202E, $C_1 - C_4 = 1\mu\text{F}$ for ST232E, $V_{CC} = 5V \pm 10\%$, $T_A = -40$ to 85°C , unless otherwise specified. Typical values are referred to $T_A = 25^\circ\text{C}$)

Symbol	Parameter	Test Conditions	Min.	Typ.	Max.	Unit
V_{TOUT}	Output Voltage Swing	All Transmitter outputs are loaded with $3K\Omega$ to GND	± 5	± 9		V
I_{TIL}	Input Leakage Current				± 1	μA
V_{TIL}	Input Logic Threshold Low		0.8			V
V_{TIH}	Input Logic Threshold High				2	V
SR_T	Transition Slew Rate	$T_A = 25^\circ\text{C}$, $V_{CC} = 5V$ $R_L = 3$ to $7K\Omega$, $C_L = 50$ to 1000pF (Note1)	3	6	30	$V/\mu\text{s}$
D_R	Data Rate	$R_L = 3$ to $7K\Omega$, $C_L = 50$ to 1000pF one transmitter switching	230	400		Kbits/s
R_{TOUT}	Transmitter Output Resistance	$V_{CC} = V_+ = V_- = 0V$ $V_{\text{OUT}} = \pm 2V$	300			Ω
I_{SC}	Transmitter Output Short Circuit Current			± 10	± 60	mA
t_{DT}	Transmitter Propagation Delay	$R_L = 3$ to $7K\Omega$, $C_L = 50$ to 2500pF All transmitter loaded		2		μs

Note 1: Measured from 3V to -3V or from -3V to 3V.

Note2: One transmitter output is loaded with $R_L = 3K\Omega$ to $7K\Omega$, $C_L = 50$ to 1000pF

RECEIVER ELECTRICAL CHARACTERISTICS

($C_1 - C_4 = 0.1\mu\text{F}$ for ST202E, $C_1 - C_4 = 1\mu\text{F}$ for ST232E, $V_{CC} = 5V \pm 10\%$, $T_A = -40$ to 85°C , unless otherwise specified. Typical values are referred to $T_A = 25^\circ\text{C}$)

Symbol	Parameter	Test Conditions	Min.	Typ.	Max.	Unit
V_{RIN}	Receiver Input Voltage Operating Range		-30		30	V
R_{RIN}	RS-232 Input Resistance	$T_A = 25^\circ\text{C}$, $V_{CC} = 5V$	3	5	7	$K\Omega$
V_{RIL}	RS-232 Input Logic Threshold Low	$T_A = 25^\circ\text{C}$, $V_{CC} = 5V$	0.8	1.2		V
V_{RIH}	RS-232 Input Logic Threshold High	$T_A = 25^\circ\text{C}$, $V_{CC} = 5V$		1.7	2.4	V
V_{RIHYS}	RS-232 Input Hysteresis	$V_{CC} = 5V$	0.2	0.5	1	V
V_{ROL}	TTL/CMOS Output Voltage Low	$I_{\text{OUT}} = 3.2\text{mA}$			0.4	V
V_{ROH}	TTL/CMOS Output Voltage High	$I_{\text{OUT}} = -1\text{mA}$	3.5	$V_{CC}-0.4$		V
t_{DR}	Receiver Propagation Delay	$C_L = 150\text{pF}$		0.5	10	μs

APPLICATION CIRCUITS (note 1, note 2)

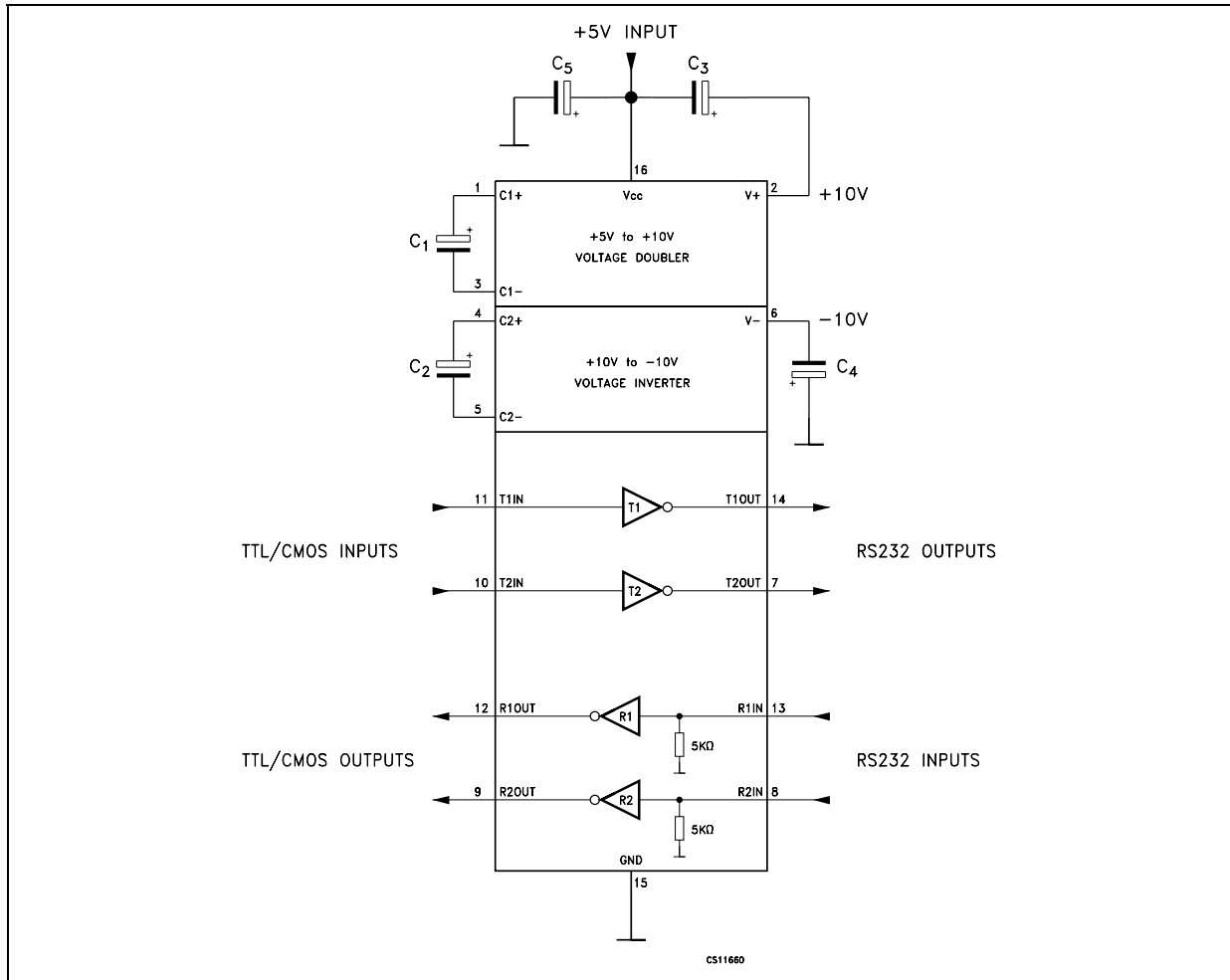

Note 1: C₁₋₄ capacitors can even be 1μF ones.
 Note 2: C₁₋₄ can be common or biased capacitors.

CAPACITANCE VALUE (μF)

DEVICES	C1	C2.	C3	C4	C5
ST202E	0.1	0.1	0.1	0.1	0.1
ST232E	1	1	1	1	1

TYPICAL PERFORMANCE CHARACTERISTICS (unless otherwise specified $T_j = 25^\circ\text{C}$)

Figure 1 : Supply Current vs Temperature

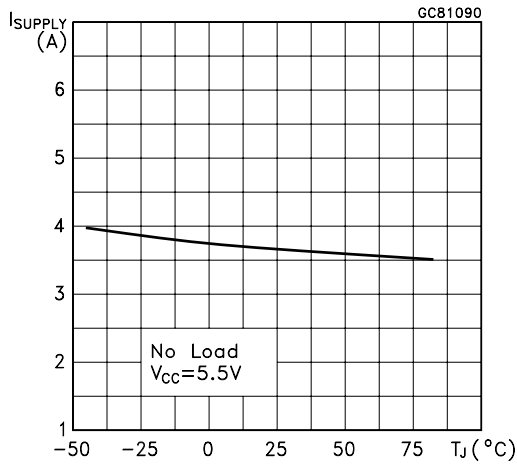

Figure 2 : Data Rate vs Temperature

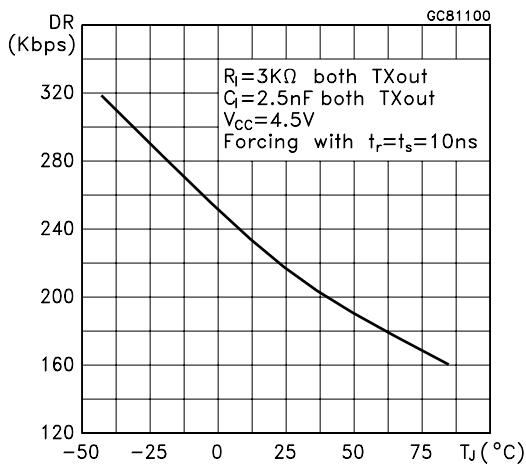

Figure 3 : Receiver Propagation Delay

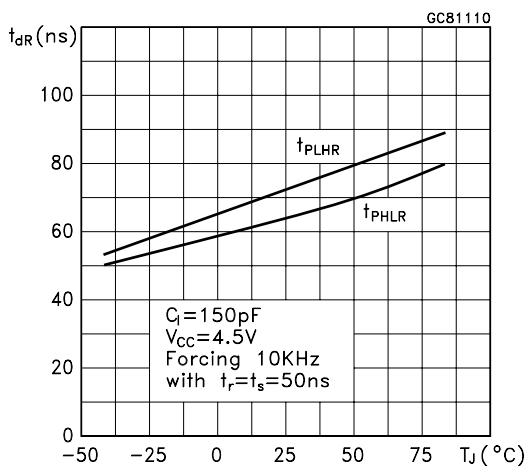

Figure 4 : Driver Propagation Delay

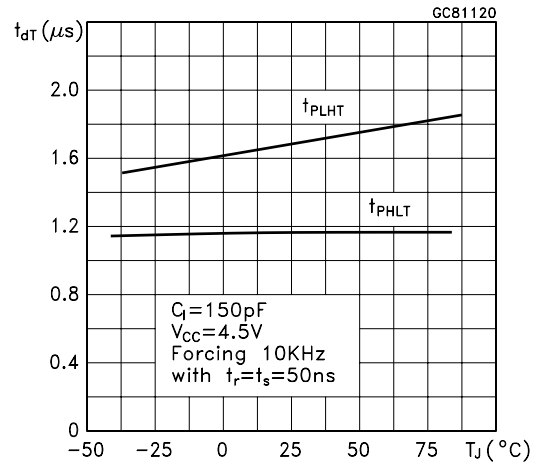

Figure 5 : High Level Output Voltage Swing vs Temperature

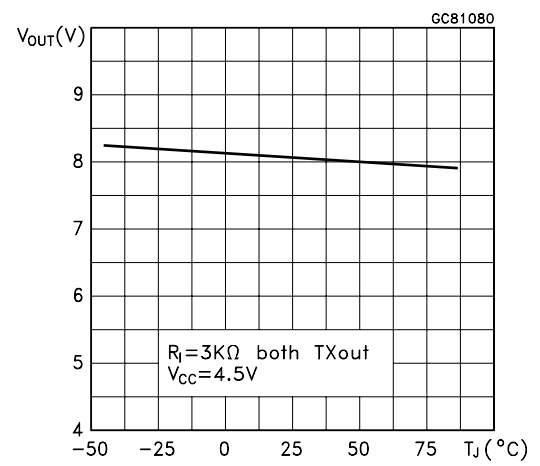

Figure 6 : Low Level Output Voltage Swing vs Temperature

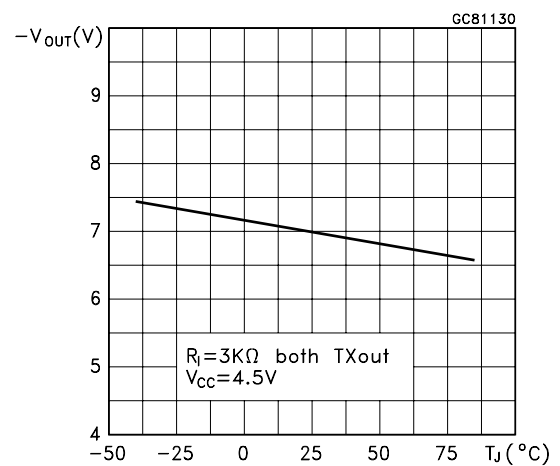

Figure 7 : High Level Transmitter Output Short Circuit Current vs Temperature

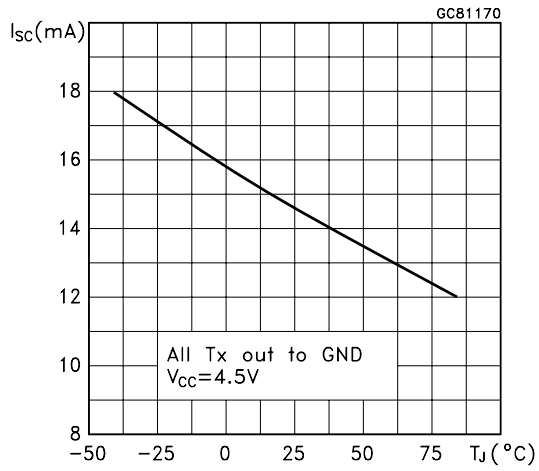

Figure 9 : High Level Receiver Output Short Circuit Current vs Temperature

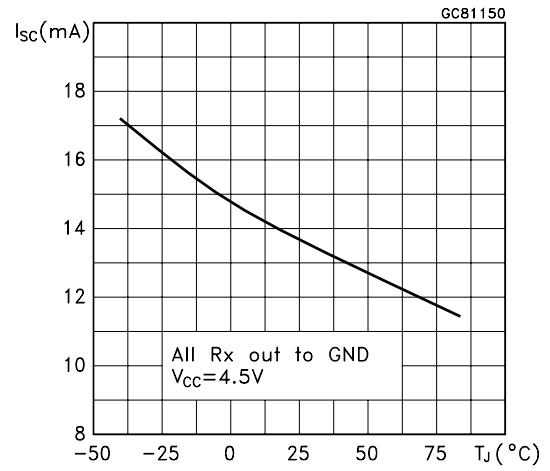

Figure 8 : Low Level Transmitter Output Short Circuit Current vs Temperature

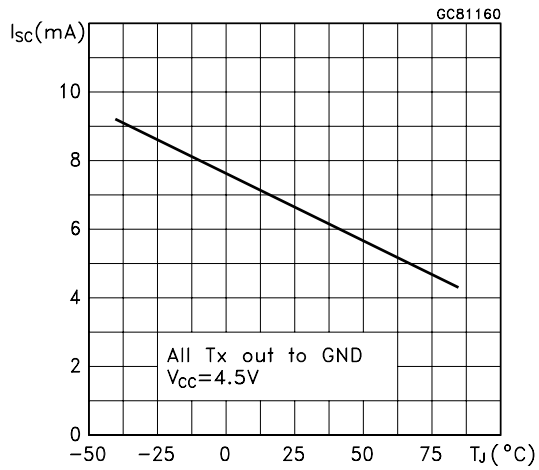
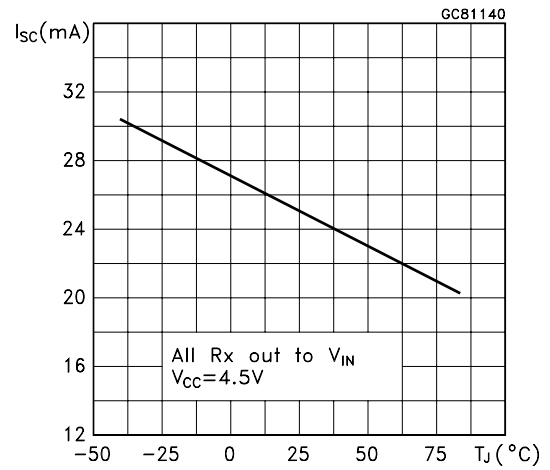
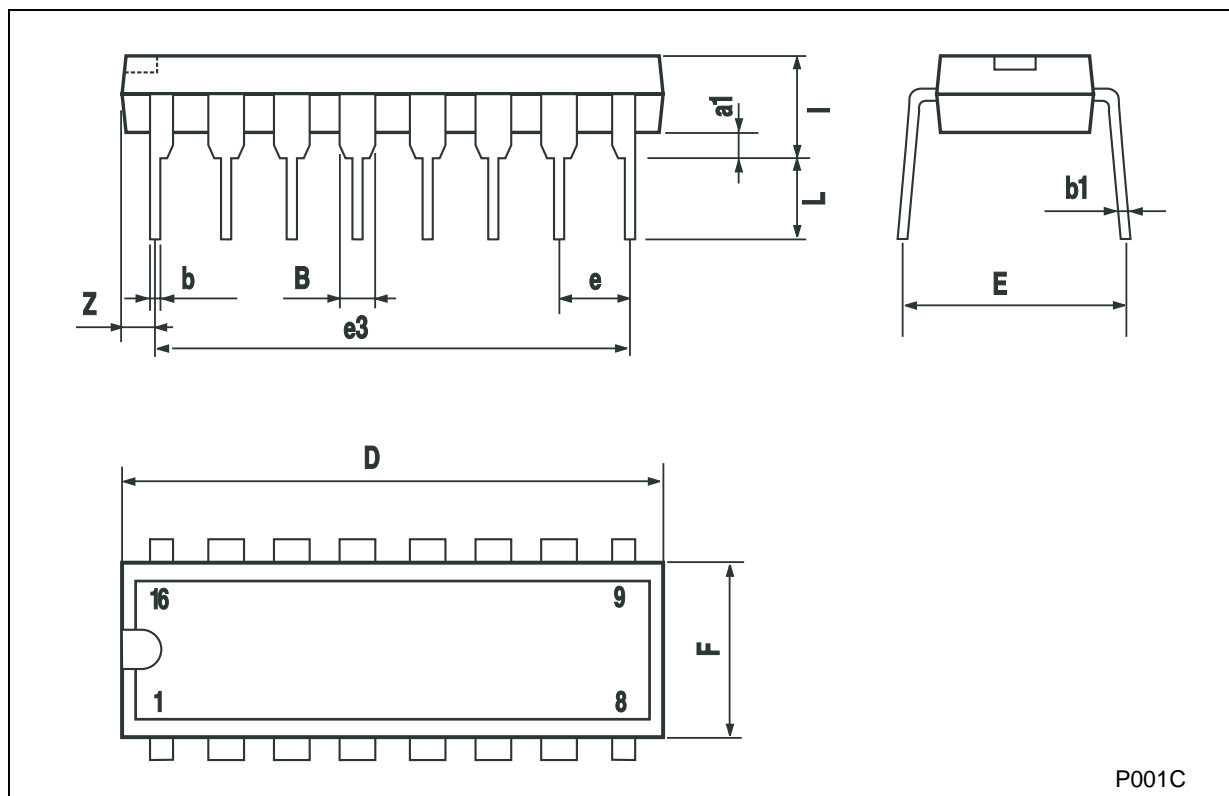

Figure 10 : Low Level Receiver Output Short Circuit Current vs Temperature



Plastic DIP-16 (0.25) MECHANICAL DATA

DIM.	mm.			inch		
	MIN.	TYP	MAX.	MIN.	TYP.	MAX.
a1	0.51			0.020		
B	0.77		1.65	0.030		0.065
b		0.5			0.020	
b1		0.25			0.010	
D			20			0.787
E		8.5			0.335	
e		2.54			0.100	
e3		17.78			0.700	
F			7.1			0.280
I			5.1			0.201
L		3.3			0.130	
Z			1.27			0.050



SO-16 MECHANICAL DATA

DIM.	mm.			inch		
	MIN.	TYP.	MAX.	MIN.	TYP.	MAX.
A			1.75			0.068
a1	0.1		0.2	0.004		0.008
a2			1.65			0.064
b	0.35		0.46	0.013		0.018
b1	0.19		0.25	0.007		0.010
C		0.5			0.019	
c1	45° (typ.)					
D	9.8		10	0.385		0.393
E	5.8		6.2	0.228		0.244
e		1.27			0.050	
e3		8.89			0.350	
F	3.8		4.0	0.149		0.157
G	4.6		5.3	0.181		0.208
L	0.5		1.27	0.019		0.050
M			0.62			0.024
S	8			° (max.)		

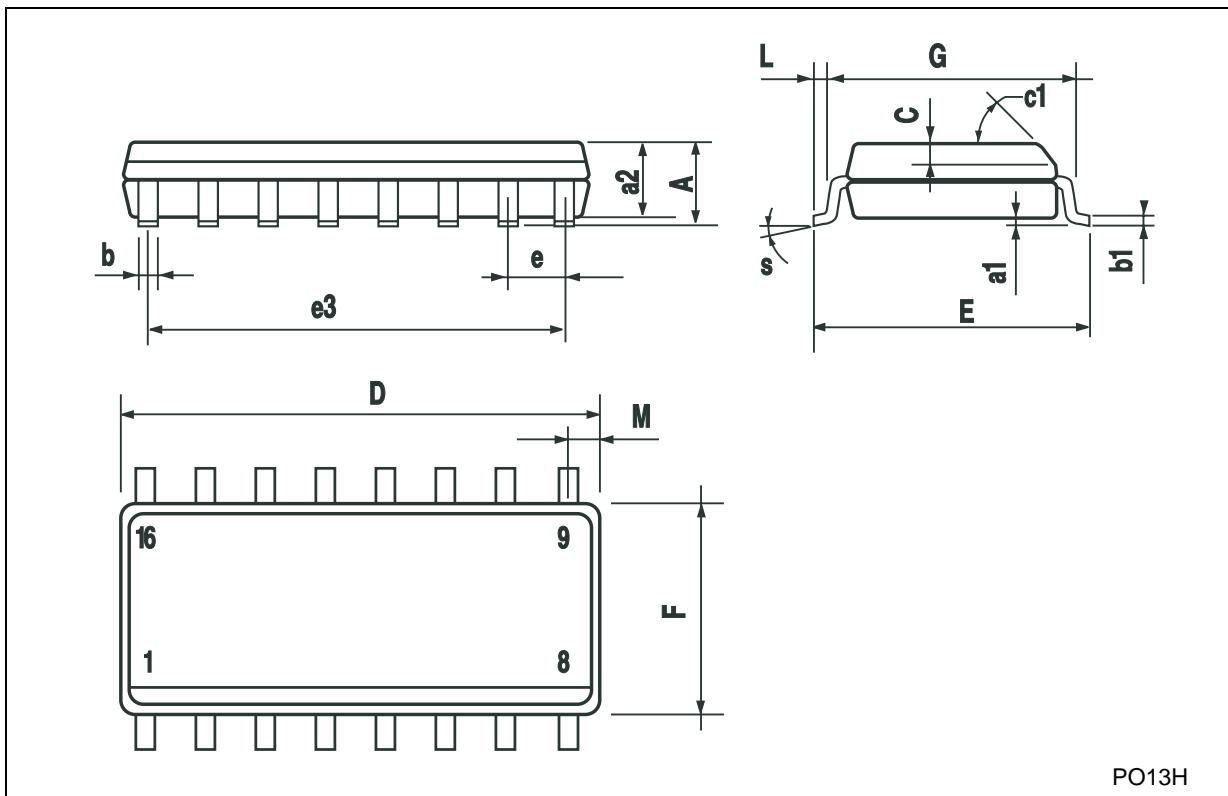

PO13H

SO-16L MECHANICAL DATA

DIM.	mm.			inch		
	MIN.	TYP.	MAX.	MIN.	TYP.	MAX.
A			2.65			0.104
a1	0.1		0.2	0.004		0.008
a2			2.45			0.096
b	0.35		0.49	0.014		0.019
b1	0.23		0.32	0.009		0.012
C		0.5			0.020	
c1	45° (typ.)					
D	10.1		10.5	0.397		0.413
E	10.0		10.65	0.393		0.419
e		1.27			0.050	
e3		8.89			0.350	
F	7.4		7.6	0.291		0.300
G						
L	0.5		1.27	0.020		0.050
M			0.75			0.029
S	8			° (max.)		

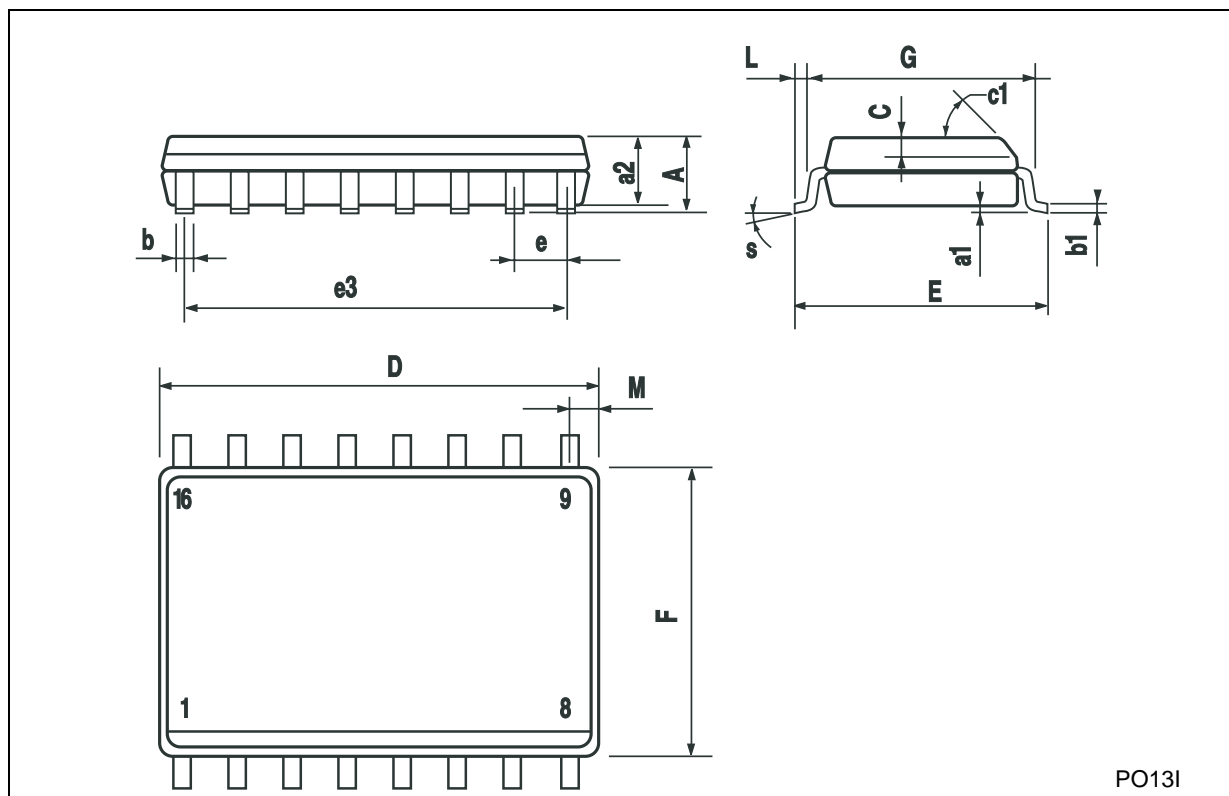

PO131

TSSOP16 MECHANICAL DATA

DIM.	mm.			inch		
	MIN.	TYP	MAX.	MIN.	TYP.	MAX.
A			1.2			0.047
A1	0.05		0.15	0.002	0.004	0.006
A2	0.8	1	1.05	0.031	0.039	0.041
b	0.19		0.30	0.007		0.012
c	0.09		0.20	0.004		0.0079
D	4.9	5	5.1	0.193	0.197	0.201
E	6.2	6.4	6.6	0.244	0.252	0.260
E1	4.3	4.4	4.48	0.169	0.173	0.176
e		0.65 BSC			0.0256 BSC	
K	0°		8°	0°		8°
L	0.45	0.60	0.75	0.018	0.024	0.030

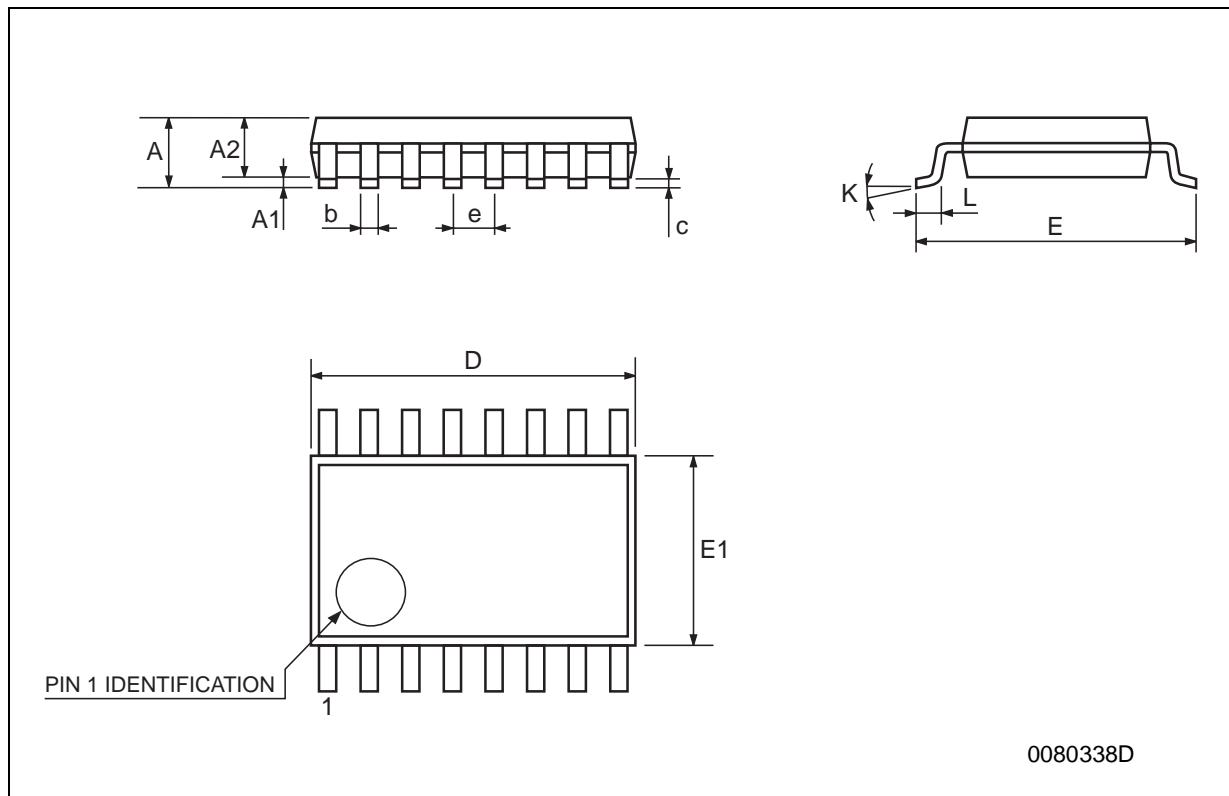

Tape & Reel SO-16 MECHANICAL DATA

DIM.	mm.			inch		
	MIN.	TYP	MAX.	MIN.	TYP.	MAX.
A			330			12.992
C	12.8		13.2	0.504		0.519
D	20.2			0.795		
N	60			2.362		
T			22.4			0.882
Ao	6.45		6.65	0.254		0.262
Bo	10.3		10.5	0.406		0.414
Ko	2.1		2.3	0.082		0.090
Po	3.9		4.1	0.153		0.161
P	7.9		8.1	0.311		0.319



Tape & Reel SO-16L MECHANICAL DATA

DIM.	mm.			inch		
	MIN.	TYP	MAX.	MIN.	TYP.	MAX.
A			330			12.992
C	12.8		13.2	0.504		0.519
D	20.2			0.795		
N	60			2.362		
T			22.4			0.882
Ao	10.8		11.0	0.425		0.433
Bo	10.7		10.9	0.421		0.429
Ko	2.9		3.1	0.114		0.122
Po	3.9		4.1	0.153		0.161
P	11.9		12.1	0.468		0.476

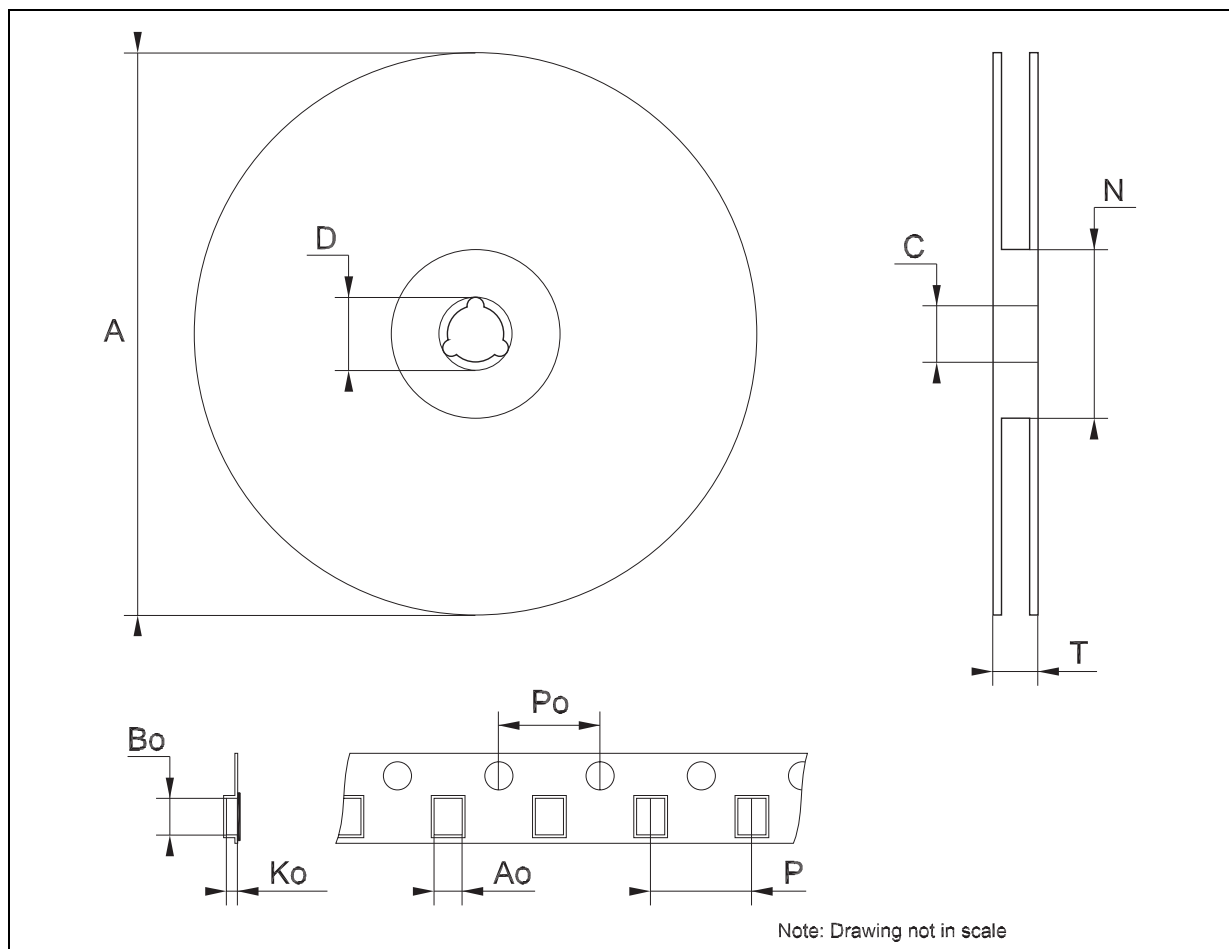

Tape & Reel TSSOP16 MECHANICAL DATA

DIM.	mm.			inch		
	MIN.	TYP	MAX.	MIN.	TYP.	MAX.
A			330			12.992
C	12.8		13.2	0.504		0.519
D	20.2			0.795		
N	60			2.362		
T			22.4			0.882
Ao	6.7		6.9	0.264		0.272
Bo	5.3		5.5	0.209		0.217
Ko	1.6		1.8	0.063		0.071
Po	3.9		4.1	0.153		0.161
P	7.9		8.1	0.311		0.319

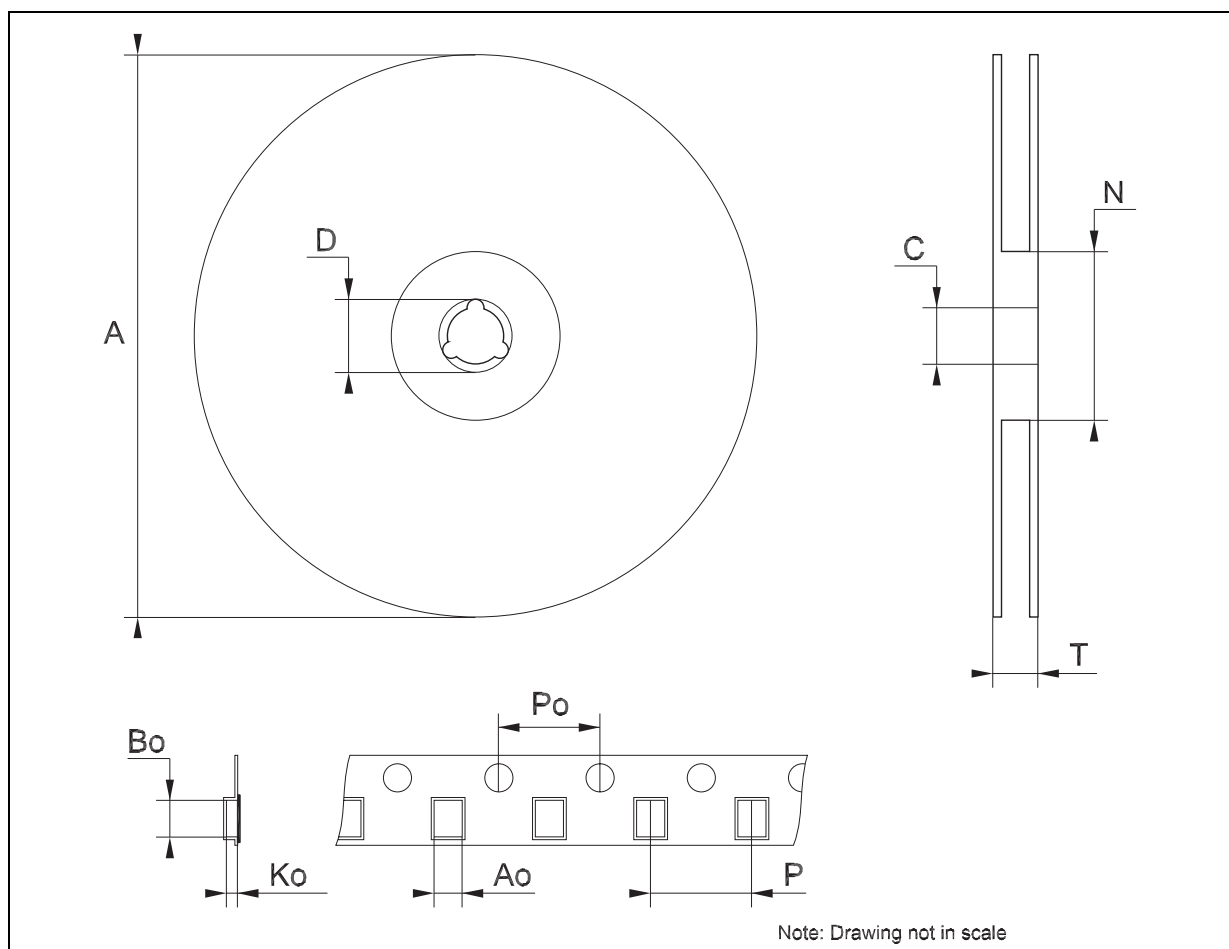

Information furnished is believed to be accurate and reliable. However, STMicroelectronics assumes no responsibility for the consequences of use of such information nor for any infringement of patents or other rights of third parties which may result from use. No license is granted by implication or otherwise under any patent or patent rights of STMicroelectronics. Specifications mentioned in this publication are subject to change without notice. This publication supersedes and replaces all information previously supplied. STMicroelectronics products are not authorized for use as critical components in life support devices or systems without express written approval of STMicroelectronics.

© The ST logo is a registered trademark of STMicroelectronics

© 2003 STMicroelectronics - Printed in Italy - All Rights Reserved
STMicroelectronics GROUP OF COMPANIES

Australia - Brazil - Canada - China - Finland - France - Germany - Hong Kong - India - Israel - Italy - Japan - Malaysia - Malta - Morocco
Singapore - Spain - Sweden - Switzerland - United Kingdom - United States.

© <http://www.st.com>