

MC9S12K Family

Device User Guide

Covers MC9S12KT256, MC9S12KG256,
MC9S12KG128, MC9S12KL128, MC9S12KC128,
MC9S12KG64, MC9S12KL64, MC9S12KC64
and MC9S12KG32

**HCS12
Microcontrollers**

9S12KT256DGV1/D
V01.09
9 SEP 2004

freescale.com



Revision History

Version Number	Revision Date	Author	Description of Changes
01.00	16 JUL 02		Original Version.
01.01	22 NOV 02		Change load cap value on VDD and VDDPLL. Correct expanded bus timing from 20MHz to 25 MHz.
01.02	15 JAN 03		Move ATD interrupt vector from \$ffd0 to \$ffd2. Change PW _{eh} and t _{DSW} parameter in external bus timing.
01.03	13 JUN 03		Expand to a K-Family SoC Guide and include 9S12KT256.
01.04	18 JUN 03		Replace 16-channel ATD with two 8-channel ATDs for 9S12KT256.
01.05	14 NOV 03		Changed to a Device User Guide and added Document number. Updated Table A-17 Oscillator Characteristics. Replaced XCLKS with PE7 for Clock Selection diagrams. Added CTRL to Table 2-1 Signal Properties. Replaced Burst programming with Row Programming in NVM electricals. Changed Digital logic to Internal Logic. Added LRAE bootloader information. Changed PW _{EL} , PW _{EH} , t _{DSW} , t _{ACCE} , t _{NAD} , t _{NAV} , t _{RWV} , t _{LSV} , t _{NOV} , t _{POV} and t _{P1V} in the external bus timing. Added voltage regulator characteristics.
01.06	10 FEB 04		Updated Table A-7 3.3V I/O Characteristics.
01.07	13 MAY 04		Updated Table A-16 NVM Timing Characteristics. Corrected A.6.1.2 Row Programming time t _{bwpgm} equation
01.08	20 JUL 04		Expanded K-family to include 9S12KC128, 9S12KC64, 9S12KL128 and 9S12KL64.
01.09	9 SEP 04		Updated oscillator start up time and supply current characteristics. Added ATDCTL0 and ATDCTL1 register bits to Sec 1.7.

Table of Contents

Section 1 Introduction

1.1	Overview	15
1.2	Features	15
1.3	Modes of Operation	17
1.4	MC9S12KG(L)(C)128(64)(32) Block Diagram	19
1.5	MC9S12KT(G)256 Block Diagram	20
1.6	Device Memory Map	21
1.7	Detailed Register Map	27
1.8	Part ID Assignments	51

Section 2 Signal Description

2.1	Device Pinout	53
2.2	Signal Properties Summary	57
2.3	Detailed Signal Descriptions	60
2.3.1	EXTAL, XTAL — Oscillator Pins	60
2.3.2	RESET — External Reset Pin	60
2.3.3	TEST — Test Pin	60
2.3.4	VREGEN — Voltage Regulator Enable Pin	60
2.3.5	XFC — PLL Loop Filter Pin	61
2.3.6	BKGD / TAGHI / MODC — Background Debug, Tag High, and Mode Pin	61
2.3.7	PAD[15:8] / AN[15:8] — Port AD Input Pins [15:8].	61
2.3.8	PAD[7:0] / AN[7:0] — Port AD Input Pins [7:0].	61
2.3.9	PA[7:0] / ADDR[15:8] / DATA[15:8] — Port A I/O Pins	61
2.3.10	PB[7:0] / ADDR[7:0] / DATA[7:0] — Port B I/O Pins	62
2.3.11	PE7 / NOACC / XCLKS — Port E I/O Pin 7	62
2.3.12	PE6 / MODB / IPIPE1 — Port E I/O Pin 6	63
2.3.13	PE5 / MODA / IPIPE0 — Port E I/O Pin 5	63
2.3.14	PE4 / ECLK — Port E I/O Pin 4	63
2.3.15	PE3 / LSTRB / TAGLO — Port E I/O Pin 3	64
2.3.16	PE2 / R/W — Port E I/O Pin 2	64
2.3.17	PE1 / IRQ — Port E Input Pin 1	64
2.3.18	PE0 / XIRQ — Port E Input Pin 0	64
2.3.19	PH7 / KWH7 / SS2 — Port H I/O Pin 7	64

2.3.20	PH6 / KWH6 / SCK2 — Port H I/O Pin 6	64
2.3.21	PH5 / KWH5 / MOSI2 — Port H I/O Pin 5	64
2.3.22	PH4 / KWH4 / MISO2 — Port H I/O Pin 2	64
2.3.23	PH3 / KWH3 / SS1 — Port H I/O Pin 3	65
2.3.24	PH2 / KWH2 / SCK1 — Port H I/O Pin 2	65
2.3.25	PH1 / KWH1 / MOSI1 — Port H I/O Pin 1	65
2.3.26	PH0 / KWH0 / MISO1 — Port H I/O Pin 0	65
2.3.27	PJ7 / KWJ7 / TXCAN4 / SCL — PORT J I/O Pin 7	65
2.3.28	PJ6 / KWJ6 / RXCAN4 / SDA — PORT J I/O Pin 6	65
2.3.29	PJ[1:0] / KWJ[1:0] — Port J I/O Pins [1:0]	65
2.3.30	PK7 / ECS / ROMCTL — Port K I/O Pin 7	65
2.3.31	PK[5:0] / XADDR[19:14] — Port K I/O Pins [5:0]	66
2.3.32	PM7 / TXCAN4 — Port M I/O Pin 7	66
2.3.33	PM6 / RXCAN4 — Port M I/O Pin 6	66
2.3.34	PM5 / TXCAN0 / TXCAN4 / SCK0 — Port M I/O Pin 5	66
2.3.35	PM4 / RXCAN0 / RXCAN4/ MOSI0 — Port M I/O Pin 4	66
2.3.36	PM3 / TXCAN1 / TXCAN0 / SS0 — Port M I/O Pin 3	67
2.3.37	PM2 / RXCAN1 / RXCAN0 / MISO0 — Port M I/O Pin 2	67
2.3.38	PM1 / TXCAN0 — Port M I/O Pin 1	67
2.3.39	PM0 / RXCAN0 — Port M I/O Pin 0	67
2.3.40	PP7 / KWP7 / PWM7 / SCK2 — Port P I/O Pin 7	67
2.3.41	PP6 / KWP6 / PWM6 / SS2 — Port P I/O Pin 6	67
2.3.42	PP5 / KWP5 / PWM5 / MOSI2 — Port P I/O Pin 5	67
2.3.43	PP4 / KWP4 / PWM4 / MISO2 — Port P I/O Pin 4	68
2.3.44	PP3 / KWP3 / PWM3 / SS1 — Port P I/O Pin 3	68
2.3.45	PP2 / KWP2 / PWM2 / SCK1 — Port P I/O Pin 2	68
2.3.46	PP1 / KWP1 / PWM1 / MOSI1 — Port P I/O Pin 1	68
2.3.47	PP0 / KWP0 / PWM0 / MISO1 — Port P I/O Pin 0	68
2.3.48	PS7 / SS0 — Port S I/O Pin 7	68
2.3.49	PS6 / SCK0 — Port S I/O Pin 6	68
2.3.50	PS5 / MOSI0 — Port S I/O Pin 5	69
2.3.51	PS4 / MISO0 — Port S I/O Pin 4	69
2.3.52	PS3 / TXD1 — Port S I/O Pin 3	69
2.3.53	PS2 / RXD1 — Port S I/O Pin 2	69
2.3.54	PS1 / TXD0 — Port S I/O Pin 1	69
2.3.55	PS0 / RXD0 — Port S I/O Pin 0	69

2.3.56	PT[7:0] / IOC[7:0] — Port T I/O Pins [7:0]	69
2.4	Power Supply Pins	69
2.4.1	VDDX, VSSX — Power Supply Pins for I/O Drivers	70
2.4.2	VDDR, VSSR — Power Supply Pins for I/O Drivers & for Internal Voltage Regulator 70	
2.4.3	VDD1, VDD2, VSS1, VSS2 — Power Supply Pins for Internal Logic	70
2.4.4	VDDA, VSSA — Power Supply Pins for ATD and VREG	70
2.4.5	VRH, VRL — ATD Reference Voltage Input Pins	70
2.4.6	VDDPLL, VSSPLL — Power Supply Pins for PLL	70

Section 3 System Clock Description

Section 4 Modes of Operation

4.1	Overview.	72
4.2	Chip Configuration Summary	72
4.3	Security.	73
4.3.1	Securing the Microcontroller	73
4.3.2	Operation of the Secured Microcontroller	74
4.3.3	Unsecuring the Microcontroller	74
4.4	Low Power Modes	74
4.4.1	Stop	74
4.4.2	Pseudo Stop.	74
4.4.3	Wait	75
4.4.4	Run.	75

Section 5 Resets and Interrupts

5.1	Overview.	76
5.2	Vectors	76
5.2.1	Vector Table.	76
5.3	Resets	78
5.3.1	Effects of Reset	78

Section 6 HCS12 Core Block Description

6.1	CPU12 Block Description	78
6.2	HCS12 Background Debug Module (BDM) Block Description	78
6.3	HCS12 Debug (DBG) Block Description	79
6.4	HCS12 Interrupt (INT) Block Description	79

6.5	HCS12 Multiplexed External Bus Interface (MEBI) Block Description	79
6.6	HCS12 Module Mapping Control (MMC) Block Description	79

Section 7 Analog to Digital Converter (ATD) Block Description

Section 8 Clock Reset Generator (CRG) Block Description

8.1	Device-specific information.	79
-----	--------------------------------------	----

Section 9 EEPROM Block Description

Section 10 Flash EEPROM Block Description

Section 11 IIC Block Description

Section 12 MSCAN Block Description

Section 13 OSC Block Description

Section 14 Port Integration Module (PIM) Block Description

Section 15 Pulse Width Modulator (PWM) Block Description

Section 16 Serial Communications Interface (SCI) Block Description

Section 17 Serial Peripheral Interface (SPI) Block Description

Section 18 Timer (TIM) Block Description

Section 19 Voltage Regulator (VREG) Block Description

19.1	Device-specific information.	82
19.1.1	VDD1, VDD2, VSS1, VSS2	82

Appendix A Electrical Characteristics

A.1	General.	83
A.1.1	Parameter Classification	83
A.1.2	Power Supply	83
A.1.3	Pins	84
A.1.4	Current Injection.	84

A.1.5	Absolute Maximum Ratings	85
A.1.6	ESD Protection and Latch-up Immunity	86
A.1.7	Operating Conditions	86
A.1.8	Power Dissipation and Thermal Characteristics	87
A.1.9	I/O Characteristics	89
A.1.10	Supply Currents	91
A.2	Voltage Regulator (VREG_3V3) Operating Characteristics	94
A.3	Chip Power-up and LVI/LVR graphical explanation	95
A.4	Output Loads	95
A.4.1	Resistive Loads	95
A.4.2	Capacitive Loads	96
A.5	ATD Characteristics	97
A.5.1	ATD Operating Characteristics	97
A.5.2	Factors influencing accuracy.	98
A.5.3	ATD accuracy.	99
A.6	NVM, Flash and EEPROM	102
A.6.1	NVM timing.	102
A.6.2	NVM Reliability.	104
A.7	Reset, Oscillator and PLL.	105
A.7.1	Startup	105
A.7.2	Oscillator	106
A.7.3	Phase Locked Loop	107
A.8	MSCAN.	111
A.9	SPI	112
A.9.1	Master Mode	112
A.9.2	Slave Mode	114
A.10	External Bus Timing	116
A.10.1	General Muxed Bus Timing	116

Appendix B Package Information

B.1	80-pin QFP package.	122
B.2	100-pin LQFP package.	123
B.3	112-pin LQFP package.	124

List of Figures

Figure 0-1	Order Part number Coding	14
Figure 1-1	MC9S12KG(L)(C)128(64)(32) Block Diagram.	19
Figure 1-2	MC9S12KT(G)256 Block Diagram.	20
Figure 1-3	MC9S12KT256 and MC9S12KG256 Memory Map	23
Figure 1-4	MC9S12KG128, MC9S12KL128 and MC9S12KC128 Memory Map	24
Figure 1-5	MC9S12KG64, MC9S12KL64 and MC9S12KC64 Memory Map	25
Figure 1-6	MC9S12KG32 Memory Map	26
Figure 2-1	Pin assignments for 112 LQFP	54
Figure 2-2	Pin assignments for 100 LQFP	55
Figure 2-3	Pin assignments for 80 QFP	56
Figure 2-4	PLL Loop Filter Connections	61
Figure 2-5	Loop Controlled Pierce Oscillator Connections (PE7=1).	62
Figure 2-6	Full Swing Pierce Oscillator Connections (PE7=0)	63
Figure 2-7	External Clock Connections (PE7=0)	63
Figure 3-1	Clock Connections.	71
Figure A-1	Voltage Regulator - Chip Power-up and Voltage Drops (not scaled)	95
Figure A-2	ATD Accuracy Definitions	101
Figure A-3	Basic PLL functional diagram	107
Figure A-4	Jitter Definitions	109
Figure A-5	SPI Master Timing (CPHA = 0)	112
Figure A-6	SPI Master Timing (CPHA =1).	113
Figure A-7	SPI Slave Timing (CPHA = 0)	114
Figure A-8	SPI Slave Timing (CPHA =1).	114
Figure A-9	General External Bus Timing.	117
Figure B-1	80-pin QFP Mechanical Dimensions (case no. 841B).	122
Figure B-2	100-pin LQFP Mechanical Dimensions (case no. 983)	123
Figure B-3	112-pin LQFP Mechanical Dimensions (case no. 987)	124

List of Tables

Table 0-1	List of MC9S12K-Family members	13
Table 0-2	Document References	14
Table 1-1	MC9S12KT(G)256 Device Memory Map	21
Table 1-2	MC9S12KG(L)(C)128(64)(32) Device Memory Map	22
Table 1-3	Detailed MSCAN Foreground Receive and Transmit Buffer Layout.	43
Table 1-4	Assigned Part ID Numbers	52
Table 1-5	Memory size registers	52
Table 2-1	Signal Properties	57
Table 2-2	Power and Ground.	59
Table 2-3	Clock selection based on PE7 during reset.	62
Table 4-1	Mode Selection	72
Table 4-2	Clock Selection Based on PE7	73
Table 4-3	Voltage Regulator VREGEN	73
Table 5-1	Interrupt Vector Locations	76
Table 5-2	Reset Summary	78
Table A-1	Absolute Maximum Ratings	85
Table A-2	ESD and Latch-up Test Conditions	86
Table A-3	ESD and Latch-Up Protection Characteristics.	86
Table A-4	Operating Conditions	87
Table A-5	Thermal Package Characteristics	89
Table A-6	5V I/O Characteristics	90
Table A-7	3.3V I/O Characteristics.	91
Table A-8	Supply Current Characteristics	93
Table A-9	VREG_3V3 - Operating Conditions	94
Table A-10	Voltage Regulator - Capacitive Loads	96
Table A-11	5V ATD Operating Characteristics.	97
Table A-12	3.3V ATD Operating Characteristics	98
Table A-13	ATD Electrical Characteristics	99
Table A-14	5V ATD Conversion Performance.	99
Table A-15	3.3V ATD Conversion Performance.	100
Table A-16	NVM Timing Characteristics	103
Table A-17	NVM Reliability Characteristics.	104
Table A-18	Startup Characteristics.	105

Table A-19	Oscillator Characteristics	106
Table A-20	PLL Characteristics.	110
Table A-21	MSCAN Wake-up Pulse Characteristics.	111
Table A-22	SPI Master Mode Timing Characteristics.	113
Table A-23	SPI Slave Mode Timing Characteristics	115
Table A-24	Expanded Bus Timing Characteristics	118

Preface

The Device User Guide provides information about the MC9S12K-Family devices made up of standard HCS12 blocks and the HCS12 processor core. This document is part of the customer documentation. A complete set of device manuals also includes all the individual Block Guides of the implemented modules. In an effort to reduce redundancy all module specific information is located only in the respective Block Guide. If applicable, special implementation details of the module are given in the block description sections of this document.

Table 0-1 shows a feature overview of the MC9S12K-Family members.

Table 0-1 List of MC9S12K-Family members

Flash	RAM	EEPROM	Device	Temp Options ¹	Package	CAN	SCI	SPI	IIC	A/D ²	PWM ²	TIM ²	I/O ³
256K	12K	4K	MC9S12KT256	C, V, M	112 LQFP	3	2	3	1	16	8	8	91
256K	12K	4K	MC9S12KG256	C, V, M	112 LQFP	2	2	3	1	16	8	8	91
					80 QFP	2	2	3	1	8	7	8	59
128K	8K	2K	MC9S12KG128	C, V, M	112 LQFP	2	2	3	1	16	8	8	91
					100 LQFP	2	2	2	1	13	7	8	79
					80 QFP	2	2	2	1	8	7	8	59
64K	4K	1K	MC9S12KG64	C, V, M	112 LQFP	2	2	2	1	16	8	8	91
					80 QFP	2	2	2	1	8	7	8	59
32K	2K	1K	MC9S12KG32	C, V, M	80 QFP	2	2	2	1	8	7	8	59
128K	6K	2K	MC9S12KL128	C, V, M	112 LQFP	1	1	2	1	16	8	8	91
					100 LQFP	1	1	2	1	13	7	8	79
					80 QFP	1	1	2	1	8	7	8	59
64K	4K	1K	MC9S12KL64	C, V, M	112 LQFP	1	1	2	1	16	8	8	91
					80 QFP	1	1	2	1	8	7	8	59
128K	6K	None	MC9S12KC128	C, V, M	112 LQFP	1	1	2	1	16	8	8	91
					100 LQFP	1	1	2	1	13	7	8	79
					80 QFP	1	1	2	1	8	7	8	59
64K	4K	None	MC9S12KC64	C, V, M	112 LQFP	1	1	2	1	16	8	8	91
					80 QFP	1	1	2	1	8	7	8	59

NOTES:

1. C: TA = 85°C, f = 25MHz. V: TA=105°C, f = 25MHz. M: TA= 125°C, f = 25MHz
2. Number of channels
3. I/O is the sum of ports capable to act as digital input or output.

Figure 0-1 shows the part number coding based on the package and temperature options for the MC9S12K-Family.

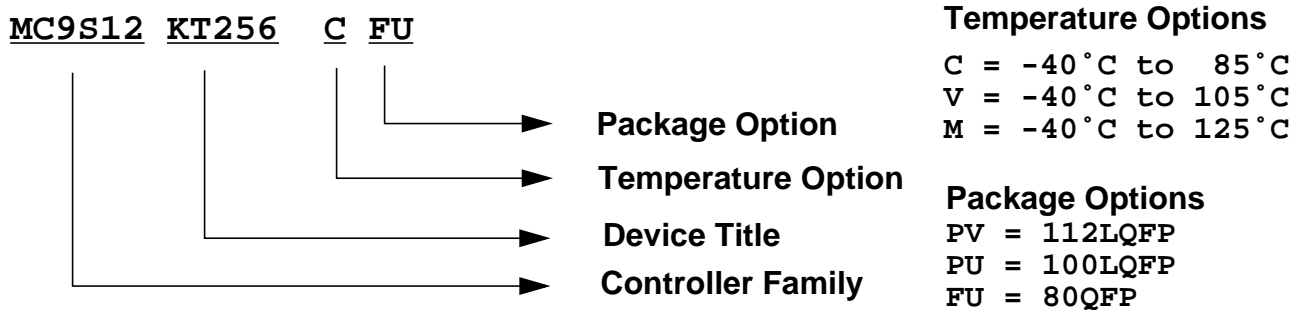

Figure 0-1 Order Part number Coding

Table 0-2 shows names and versions of the referenced documents throughout the Device User Guide.

Table 0-2 Document References

User Guide	Version	Document Order Number
CPU12 Reference Manual	V02	S12CPUV2/D
HCS12 Background Debug (BDM) Block Guide	V04	S12BDMV4/D
HCS12 Debug (DBG) Block Guide	V01	S12DBGV1/D
HCS12 Interrupt (INT) Block Guide	V01	S12INTV1/D
HCS12 Multiplexed Expanded Bus Interface (MEBI) Block Guide	V03	S12MEBIV3/D
HCS12 Module Mapping Control (MMC) Block Guide	V04	S12MMCV4/D
Analog to Digital Converter: 10-Bit, 16 Channels (ATD_10B16C) Block Guide	V03	S12ATD10B16CV3/D ¹
Analog to Digital Converter: 10-Bit, 8 Channels (ATD_10B8C) Block Guide	V03	S12ATD10B8CV3/D ²
Clock and Reset Generator (CRG) Block Guide	V04	S12CRGV4/D
2K Byte EEPROM (EETS2K) Block Guide	V01	S12EETS2KV1/D ⁽¹⁾
4K Byte EEPROM (EETS4K) Block Guide	V02	S12EETS4KV2/D ⁽²⁾
128K Byte Flash with Error Code Correction (FTS128K1ECC) Block Guide	V01	FTS128K1ECCV1/D ⁽¹⁾
256K Byte Flash with Error Code Correction (FTS256K2ECC) Block Guide	V01	FTS256K2ECCV1/D ⁽²⁾
Inter IC Bus (IIC) Block Guide	V02	S12IICV2/D
Motorola Scalable CAN (MSCAN) Block Guide	V02	S12MSCANV2/D
Oscillator Loop Control Pierce (OSC_LCP) Block Guide	V01	S12OSCLCPV1/D
Port Integration Module ⁽¹⁾ (PIM_9KG128) Block Guide	V01	S12KG128PIMV1/D
Port Integration Module ⁽²⁾ (PIM_9KT256) Block Guide	V01	S12KT256PIMV1/D
Pulse Width Modulator 8 Bit 8 Channel (PWM_8B8C) Block Guide	V01	S12PWM8B6CV1/D
Serial Communications Interface (SCI) Block Guide	V02	S12SCIV2/D
Serial Peripheral Interface (SPI) Block Guide	V03	S12SPIV3/D
Timer: 16-Bit, 8 Channels (TIM_16B8C) Block Guide	V01	S12TIM16B8CV1/D
Voltage Regulator (VREG_3V3) Block Guide	V01	S12VREG3V3V1/D

NOTES:

1. Block Guide for MC9S12K-Family except MC9S12KT256 and MC9S12KG256.
2. Block Guide for MC9S12KT256 and MC9S12KG256 only.

Section 1 Introduction

1.1 Overview

The MC9S12K-Family is a 112/100/80 pin 16-bit Flash-based microcontroller family targeted for high reliability systems. Members of the MC9S12K-Family have an increased performance in reliability over the life of the product due to a built-in Error Checking and Correction Code (ECC) in the Flash memory. The program and erase operations automatically generate six parity bits per word making ECC transparent to the user.

All members of the MC9S12K-Family are comprised of standard on-chip peripherals including a 16-bit central processing unit (CPU12), up to 256K bytes of Flash EEPROM, up to 4K bytes of EEPROM, up to 12K bytes of RAM, up to two asynchronous serial communications interface (SCI), up to three serial peripheral interface (SPI), IIC-bus, an 8-channel IC/OC timer, 16-channel or two 8-channel 10-bit analog-to-digital converters (ADC), an 8-channel pulse-width modulator (PWM), up to three CAN 2.0 A, B software compatible modules, 29 discrete digital I/O channels (Port A, Port B, Port E and Port K), and 20 discrete digital I/O lines with interrupt and wakeup capability. The MC9S12K-Family has full 16-bit data paths throughout, however, the external bus can operate in an 8-bit narrow mode so single 8-bit wide memory can be interfaced for lower cost systems. The inclusion of a PLL circuit allows power consumption and performance to be adjusted to suit operational requirements.

1.2 Features

- HCS12 Core
 - 16-bit HCS12 CPU
 - i. Upward compatible with M68HC11 instruction set
 - ii. Interrupt stacking and programmer's model identical to M68HC11
 - iii. Instruction queue
 - iv. Enhanced indexed addressing
 - MEBI (Multiplexed External Bus Interface)
 - MMC (Memory Map and Interface)
 - INT (Interrupt Controller)
 - DBG (Debugger)
 - BDM (Background Debug Mode)
- Oscillator
 - 4Mhz to 16Mhz frequency range
 - Pierce with amplitude loop control
 - Clock monitor

- Clock and Reset Generator (CRG)
 - Phase-locked loop clock frequency multiplier
 - Self Clock mode in absence of external clock
 - COP watchdog
 - Real Time interrupt (RTI)
- Memory
 - 32K, 64K, 128K or 256K Byte Flash EEPROM
 - i. Internal program/erase voltage generation
 - ii. Security and Block Protect bits
 - iii. Hamming Error Correction Coding (ECC)
 - 1K, 2K or 4K Byte EEPROM
 - 2K, 4K, 6K, 8K or 12K Byte static RAM
 - Single-cycle misaligned word accesses without wait states
- Analog-to-Digital Converter(s) (ADC)
 - One 16-channel module with 10-bit resolution except for MC9S12KT256 and MC9S12KG256
 - Two 8-channel module with 10-bit resolution for MC9S12KT256 and MC9S12KG256
 - External conversion trigger capability
- 8-channel Timer (TIM)
 - Programmable input capture or output compare channels
 - Simple PWM mode
 - Counter Modulo Reset
 - External Event Counting
 - Gated Time Accumulation
- 8-channel Pulse Width Modulator (PWM)
 - Programmable period and duty cycle per channel
 - 8-bit 8-channel or 16-bit 4-channel
 - Edge and center aligned PWM signals
 - Emergency shutdown input
- Two or Three 1M bit per second, CAN 2.0 A, B software compatible modules
 - Five receive and three transmit buffers
 - Flexible identifier filter programmable as 2 x 32 bit, 4 x 16 bit or 8 x 8 bit
 - Four separate interrupt channels for Rx, Tx, error and wake-up

- Low-pass filter wake-up function
- Loop-back for self test operation
- Serial interfaces
 - Two asynchronous serial communication interface (SCI)
 - Three synchronous serial peripheral interface (SPI)
 - Inter-IC Bus (IIC)
- Internal 2.5V Regulator
 - Input voltage range from 3.15V to 5.5V
 - Low power mode capability
 - Low Voltage Reset (LVR) and Low Voltage Interrupt (LVI)
- 20 key wake up inputs
 - Rising or falling edge triggered interrupt capability
 - Digital filter to prevent short pulses from triggering interrupts
 - Programmable pull ups and pull downs
- Operating frequency for ambient temperatures (T_A -40°C to 125°C)
 - 50MHz equivalent to 25MHz Bus Speed
- 112-Pin LQFP, 100-Pin LQFP, or 80-Pin QFP package
 - I/O lines with 3.3V/5V input and drive capability
 - 3.3V/5V A/D converter inputs

1.3 Modes of Operation

- Normal modes
 - Normal Single-Chip Mode
 - Normal Expanded Wide Mode
 - Normal Expanded Narrow Mode
 - Emulation Expanded Wide Mode
 - Emulation Expanded Narrow Mode
- Special Operating Modes
 - Special Single-Chip Mode with active Background Debug Mode
 - Special Test Mode (Motorola use only)
 - Special Peripheral Mode (Motorola use only)
- Each of the above modes of operation can be configured for three Low power submodes

- Stop Mode
- Pseudo Stop Mode
- Wait Mode
- Secure operation, preventing the unauthorized read and write of the memory contents.

1.4 MC9S12KG(L)(C)128(64)(32) Block Diagram

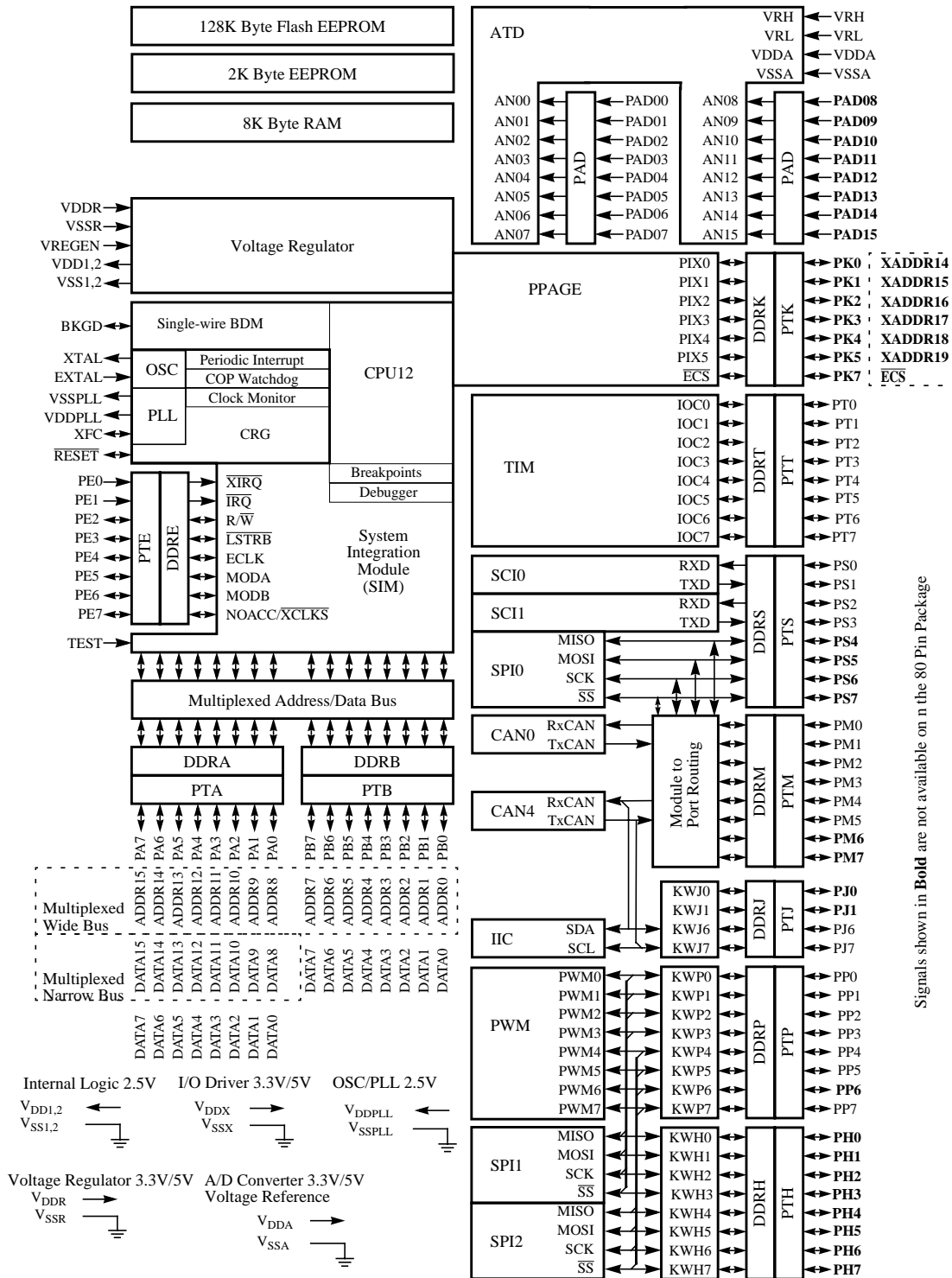

Figure 1-1 MC9S12KG(L)(C)128(64)(32) Block Diagram

1.5 MC9S12KT(G)256 Block Diagram

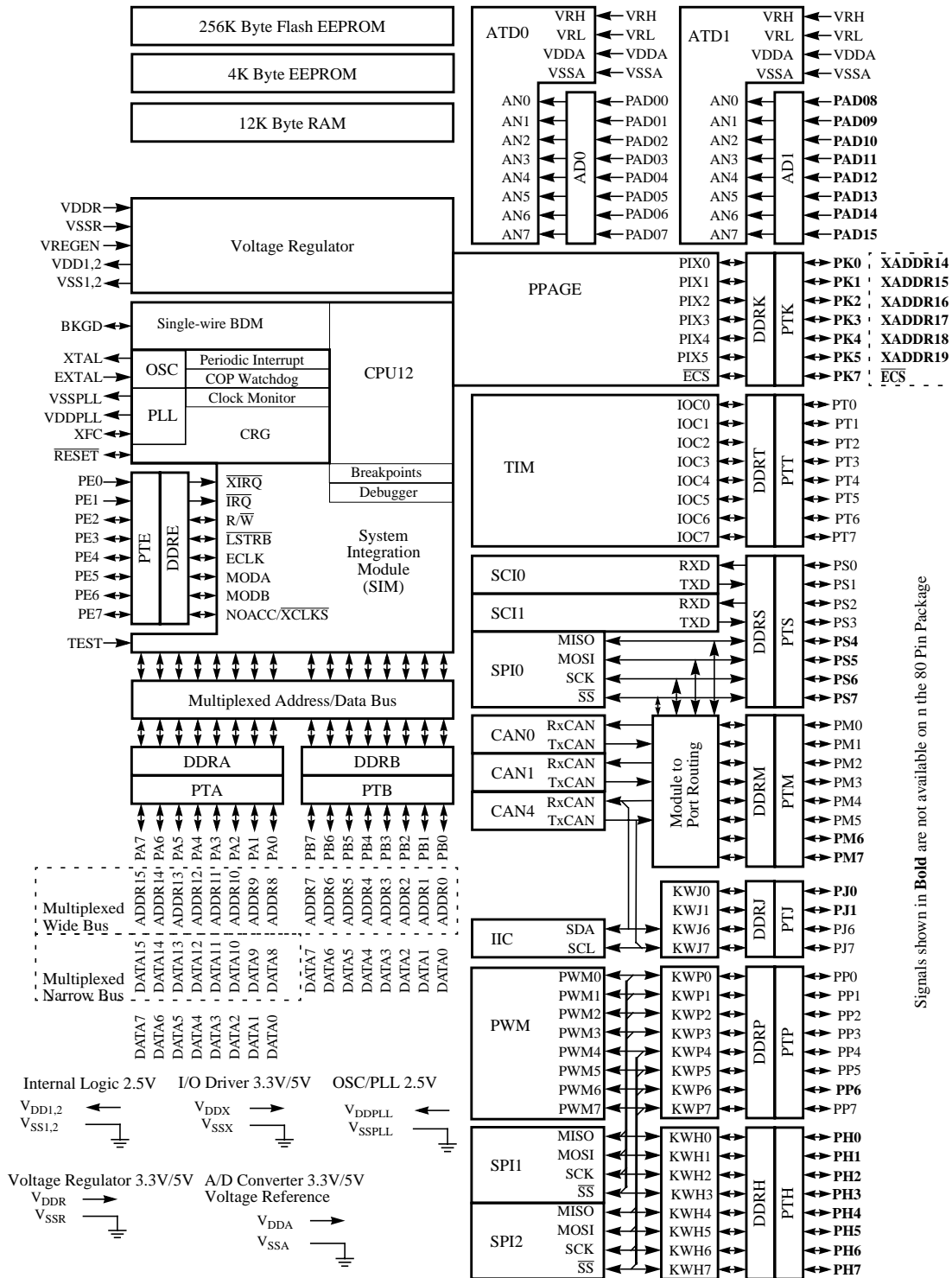

Figure 1-2 MC9S12KT(G)256 Block Diagram

1.6 Device Memory Map

Table 1-1 shows the device register map of the MC9S12KT256 and MC9S12KG256 after reset. **Table 1-2** shows the device register map of the MC9S12KG128(64)(32), MC9S12KL128(64) and MC9S12KC128(64) after reset.

Table 1-1 MC9S12KT(G)256 Device Memory Map

Address	Module	Size
\$000 - \$017	CORE (Ports A, B, E, Modes, Inits, Test)	24
\$018	Reserved	1
\$019	Voltage Regulator (VREG)	1
\$01A - \$01B	Device ID register (PARTID)	2
\$01C - \$01F	CORE (MEMSIZ, IRQ, HPRIO)	4
\$020 - \$02F	CORE (DBG)	16
\$030 - \$033	CORE (PPAGE, Port K)	4
\$034 - \$03F	Clock and Reset Generator (PLL, RTI, COP)	12
\$040 - \$06F	Standard Timer 16-bit 8 channels (TIM)	48
\$070 - \$07F	Reserved	16
\$080 - \$09F	Analog to Digital Converter 10-bit 8 channels (ATD0)	32
\$0A0 - \$0C7	Reserved	40
\$0C8 - \$0CF	Serial Communications Interface 0 (SCI0)	8
\$0D0 - \$0D7	Serial Communications Interface 1 (SCI1)	8
\$0D8 - \$0DF	Serial Peripheral Interface 0 (SPI0)	8
\$0E0 - \$0E7	Inter Integrated Circuit Bus (IIC)	8
\$0E8 - \$0EF	Reserved	8
\$0F0 - \$0F7	Serial Peripheral Interface 1 (SPI1)	8
\$0F8 - \$0FF	Serial Peripheral Interface 2 (SPI2)	8
\$100 - \$10F	Flash Control Register	16
\$110 - \$11B	EEPROM Control Register	12
\$11C - \$11F	Reserved	4
\$120 - \$13F	Analog to Digital Converter 10-bit 8 channels (ATD1)	32
\$140 - \$17F	Motorola Scalable Controller Area Network 0 (CAN0)	64
\$180 - \$1BF	Motorola Scalable Controller Area Network 1 (CAN1)	64
\$1C0 - \$23F	Reserved	128
\$240 - \$27F	Port Integration Module (PIM)	64
\$280 - \$2BF	Motorola Scalable Controller Area Network 4 (CAN4)	64
\$2C0 - \$2E7	Pulse Width Modulator 8-bit 8 channels (PWM)	40
\$2E8 - \$3FF	Reserved	280

Table 1-2 MC9S12KG(L)(C)128(64)(32) Device Memory Map

Address	Module	Size
\$000 - \$017	CORE (Ports A, B, E, Modes, Inits, Test)	24
\$018	Reserved	1
\$019	Voltage Regulator (VREG)	1
\$01A - \$01B	Device ID register (PARTID)	2
\$01C - \$01F	CORE (MEMSIZ, IRQ, HPRIO)	4
\$020 - \$02F	CORE (DBG)	16
\$030 - \$033	CORE (PPAGE, Port K)	4
\$034 - \$03F	Clock and Reset Generator (PLL, RTI, COP)	12
\$040 - \$06F	Standard Timer 16-bit 8 channels (TIM)	48
\$070 - \$07F	Reserved	16
\$080 - \$0AF	Analog to Digital Converter 10-bit 16 channels (ATD)	48
\$0B0 - \$0C7	Reserved	24
\$0C8 - \$0CF	Serial Communications Interface 0 (SCI0)	8
\$0D0 - \$0D7	Serial Communications Interface 1 (SCI1)	8
\$0D8 - \$0DF	Serial Peripheral Interface 0 (SPI0)	8
\$0E0 - \$0E7	Inter Integrated Circuit Bus (IIC)	8
\$0E8 - \$0EF	Reserved	8
\$0F0 - \$0F7	Serial Peripheral Interface 1 (SPI1)	8
\$0F8 - \$0FF	Serial Peripheral Interface 2 (SPI2)	8
\$100 - \$10F	Flash Control Register	16
\$110 - \$11B	EEPROM Control Register	12
\$11C - \$13F	Reserved	36
\$140 - \$17F	Motorola Scalable Controller Area Network 0 (CAN0)	64
\$180 - \$23F	Reserved	192
\$240 - \$27F	Port Integration Module (PIM)	64
\$280 - \$2BF	Motorola Scalable Controller Area Network 4 (CAN4)	64
\$2C0 - \$2E7	Pulse Width Modulator 8-bit 8 channels (PWM)	40
\$2E8 - \$3FF	Reserved	280

Figure 1-4 illustrates the full user configurable device memory map of MC9S12KT256 and MC9S12KG256.

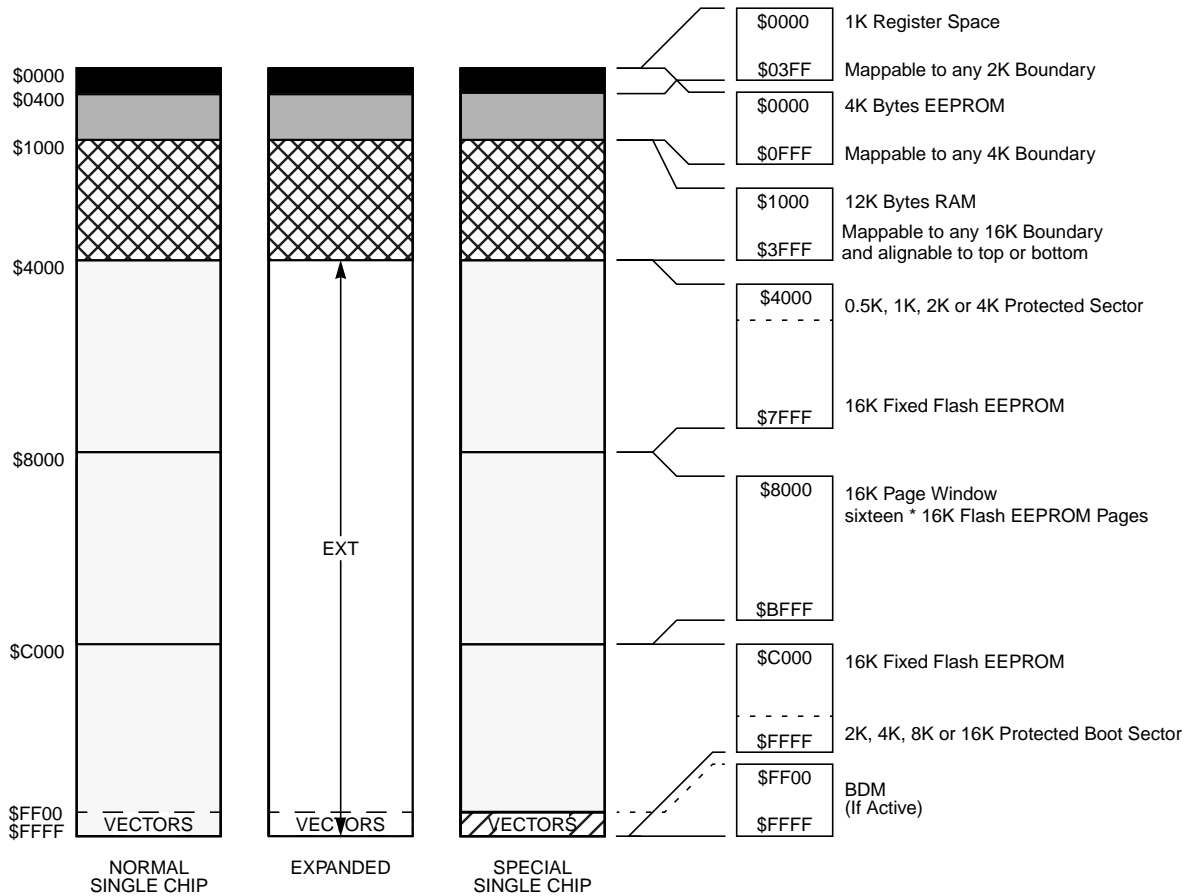

The figure shows a useful map, which is not the map out of reset. After reset the map is:

- \$0000 - \$03FF: Register Space
- \$1000 - \$3FFF: 12K RAM
- \$0000 - \$0FFF: 4K EEPROM (1K hidden behind Register Space)

Figure 1-3 MC9S12KT256 and MC9S12KG256 Memory Map

Figure 1-4 illustrates the full user configurable device memory map of MC9S12KG128, MC9S12KL128 and MC9S12KC128.

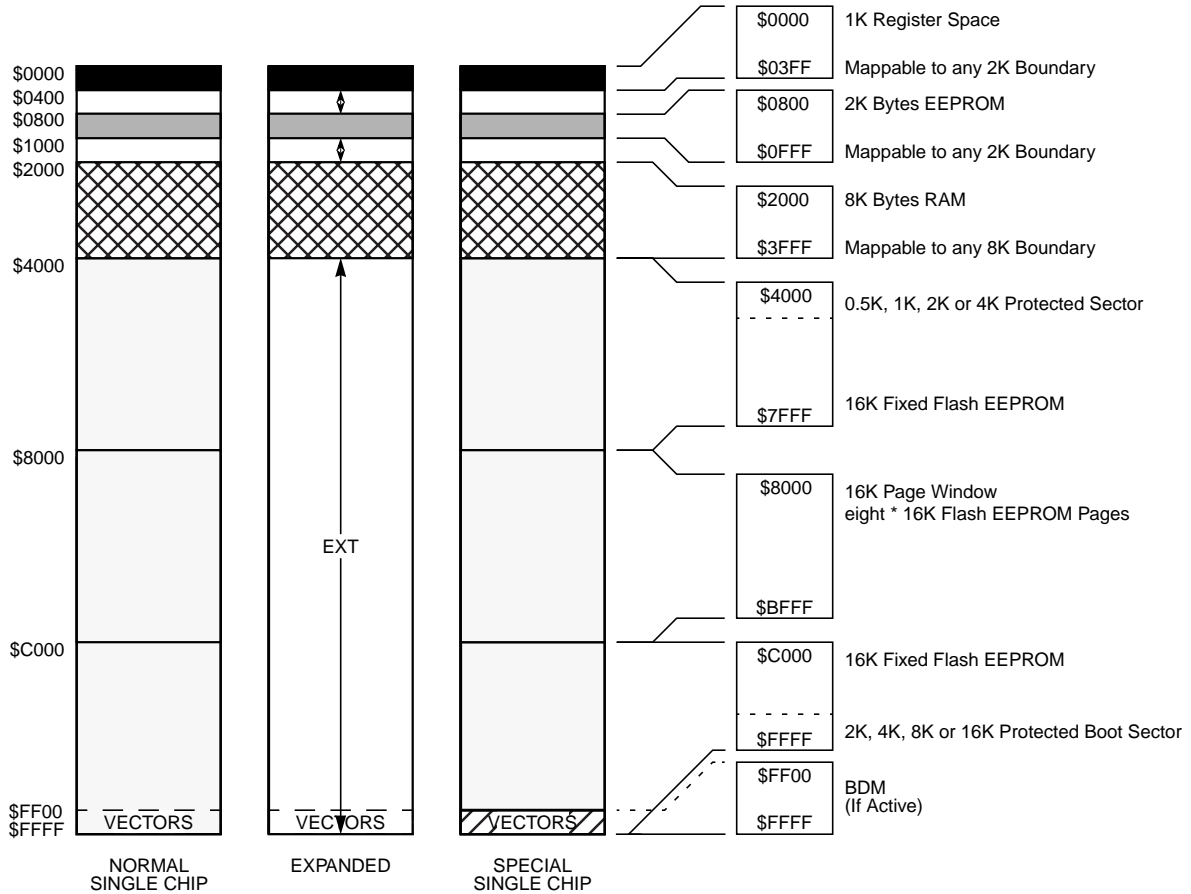

The figure shows a useful map, which is not the map out of reset. After reset the map is:

- \$0000 - \$03FF: Register Space
- \$0000 - \$1FFF: 8K RAM (1K RAM hidden behind Register Space)
- \$0000 - \$07FF: 2K EEPROM (not visible)

Figure 1-4 MC9S12KG128, MC9S12KL128 and MC9S12KC128 Memory Map

Figure 1-5 illustrates the full user configurable device memory map of MC9S12KG64, MC9S12KL64 and MC9S12KC64.

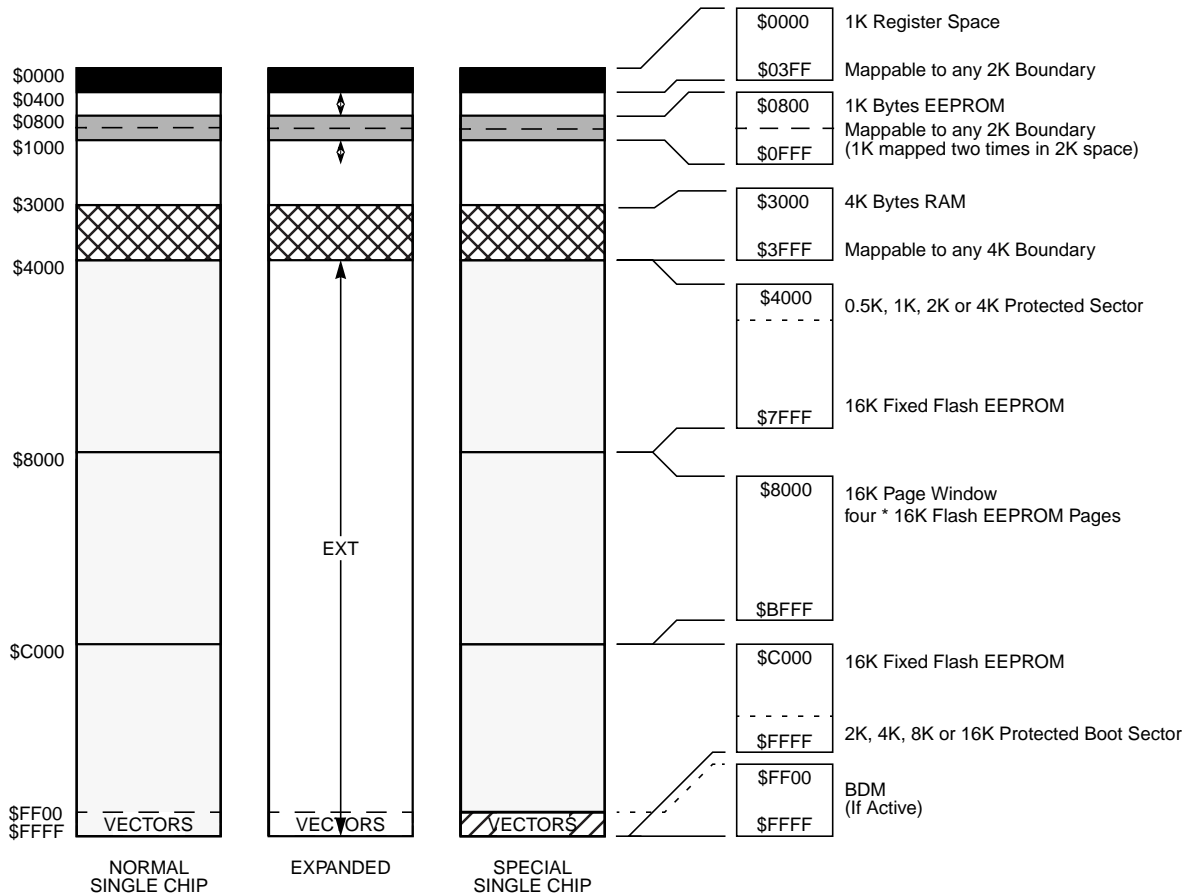

The figure shows a useful map, which is not the map out of reset. After reset the map is:

- \$0000 - \$03FF: Register Space
- \$0000 - \$0FFF: 4K RAM (1K RAM hidden behind Register Space)
- \$0000 - \$03FF: 1K EEPROM (not visible)

Figure 1-5 MC9S12KG64, MC9S12KL64 and MC9S12KC64 Memory Map

Figure 1-6 illustrates the full user configurable device memory map of MC9S12KG32.

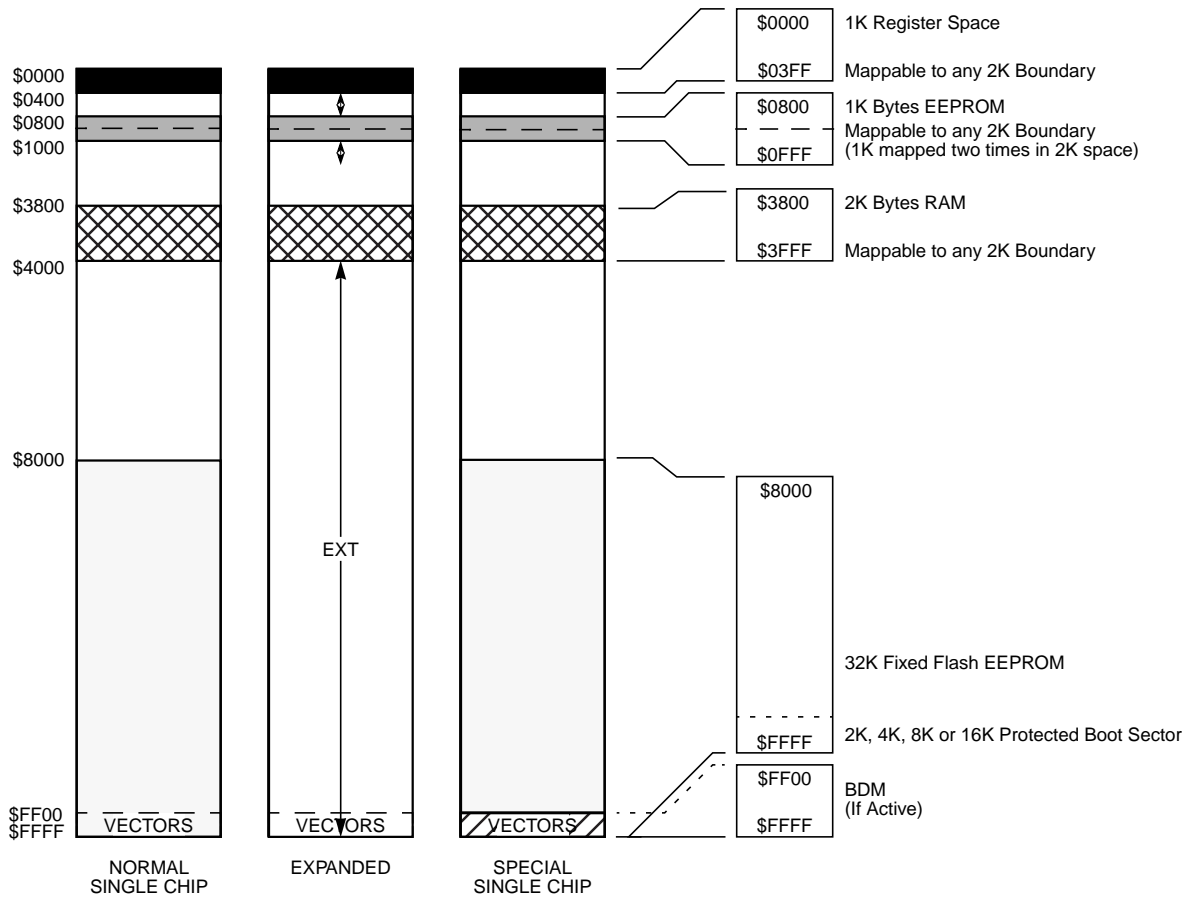

The figure shows a useful map, which is not the map out of reset. After reset the map is:

- \$0000 - \$03FF: Register Space
- \$0000 - \$07FF: 2K RAM (1K RAM hidden behind Register Space)
- \$0000 - \$03FF: 1K EEPROM (not visible)

Figure 1-6 MC9S12KG32 Memory Map

1.7 Detailed Register Map

The following tables show the detailed register map of the MC9S12K-Family.

\$0000 - \$000F

MEBI map 1 of 3 (HCS12 Multiplexed External Bus Interface)

Address	Name		Bit 7	Bit 6	Bit 5	Bit 4	Bit 3	Bit 2	Bit 1	Bit 0
\$0000	PORTA	Read: Write:	Bit 7	6	5	4	3	2	1	Bit 0
\$0001	PORTB	Read: Write:	Bit 7	6	5	4	3	2	1	Bit 0
\$0002	DDRA	Read: Write:	Bit 7	6	5	4	3	2	1	Bit 0
\$0003	DDRB	Read: Write:	Bit 7	6	5	4	3	2	1	Bit 0
\$0004	Reserved	Read: Write:	0	0	0	0	0	0	0	0
\$0005	Reserved	Read: Write:	0	0	0	0	0	0	0	0
\$0006	Reserved	Read: Write:	0	0	0	0	0	0	0	0
\$0007	Reserved	Read: Write:	0	0	0	0	0	0	0	0
\$0008	PORTE	Read: Write:	Bit 7	6	5	4	3	2	Bit 1	Bit 0
\$0009	DDRE	Read: Write:	Bit 7	6	5	4	3	Bit 2	0	0
\$000A	PEAR	Read: Write:	NOACCE	0	PIPOE	NECLK	LSTRE	RDWE	0	0
\$000B	MODE	Read: Write:	MODC	MODB	MODA	0	IVIS	0	EMK	EME
\$000C	PUCR	Read: Write:	PUPKE	0	0	PUPEE	0	0	PUPBE	PUPAE
\$000D	RDRIV	Read: Write:	RDPK	0	0	RDPE	0	0	RDPB	RDPA
\$000E	EBICTL	Read: Write:	0	0	0	0	0	0	0	ESTR
\$000F	Reserved	Read: Write:	0	0	0	0	0	0	0	0

\$0010 - \$0014

MMC map 1 of 4 (HCS12 Module Mapping Control)

Address	Name		Bit 7	Bit 6	Bit 5	Bit 4	Bit 3	Bit 2	Bit 1	Bit 0
\$0010	INITRM	Read: Write:	RAM15	RAM14	RAM13	RAM12	RAM11	0	0	RAMHAL
\$0011	INITRG	Read: Write:	0	REG14	REG13	REG12	REG11	0	0	0

\$0010 - \$0014

MMC map 1 of 4 (HCS12 Module Mapping Control)

Address	Name	Read:	Bit 7	Bit 6	Bit 5	Bit 4	Bit 3	Bit 2	Bit 1	Bit 0
\$0012	INITEE	Read:	EE15	EE14	EE13	EE12	EE11	0	0	EEON
		Write:								
\$0013	MISC	Read:	0	0	0	0	EXSTR1	EXSTR0	ROMHM	ROMON
		Write:								
\$0014	Reserved	Read:	0	0	0	0	0	0	0	0
		Write:								

\$0015 - \$0016

INT map 1 of 2 (HCS12 Interrupt)

Address	Name	Read:	Bit 7	Bit 6	Bit 5	Bit 4	Bit 3	Bit 2	Bit 1	Bit 0
\$0015	ITCR	Read:	0	0	0	WRINT	ADR3	ADR2	ADR1	ADR0
		Write:								
\$0016	ITEST	Read:	INTE	INTC	INTA	INT8	INT6	INT4	INT2	INT0
		Write:								

\$0017 - \$0017

MMC map 2 of 4 (HCS12 Module Mapping Control)

Address	Name	Read:	Bit 7	Bit 6	Bit 5	Bit 4	Bit 3	Bit 2	Bit 1	Bit 0
\$0017	Reserved	Read:	0	0	0	0	0	0	0	0
		Write:								

\$0018 - \$0018

Miscellaneous Peripherals (Device Guide)

Address	Name	Read:	Bit 7	Bit 6	Bit 5	Bit 4	Bit 3	Bit 2	Bit 1	Bit 0
\$0018	Reserved	Read:	0	0	0	0	0	0	0	0
		Write:								

\$0019 - \$0019

VREG3V3 (Voltage Regulator)

Address	Name	Read:	Bit 7	Bit 6	Bit 5	Bit 4	Bit 3	Bit 2	Bit 1	Bit 0
\$0019	VREGCTRL	Read:	0	0	0	0	0	LVDS	LVIE	LVIF
		Write:								

\$001A - \$001B

Miscellaneous Peripherals (Device Guide)

Address	Name	Read:	Bit 7	Bit 6	Bit 5	Bit 4	Bit 3	Bit 2	Bit 1	Bit 0
\$001A	PARTIDH	Read:	ID15	ID14	ID13	ID12	ID11	ID10	ID9	ID8
		Write:								
\$001B	PARTIDL	Read:	ID7	ID6	ID5	ID4	ID3	ID2	ID1	ID0
		Write:								

\$001C - \$001D
Guide)
MMC map 3 of 4 (HCS12 Module Mapping Control, Device

Address	Name	Bit 7	Bit 6	Bit 5	Bit 4	Bit 3	Bit 2	Bit 1	Bit 0
\$001C	MEMSIZ0	Read: reg_sw0	0	eep_sw1	eep_sw0	0	ram_sw2	ram_sw1	ram_sw0
		Write:							
\$001D	MEMSIZ1	Read: rom_sw1	rom_sw0	0	0	0	0	pag_sw1	pag_sw0
		Write:							

\$001E - \$001E
MEBI map 2 of 3 (HCS12 Multiplexed External Bus Interface)

Address	Name	Bit 7	Bit 6	Bit 5	Bit 4	Bit 3	Bit 2	Bit 1	Bit 0
\$001E	INTCR	Read: IRQE	IRQEN	0	0	0	0	0	0
		Write:							

\$001F - \$001F
INT map 2 of 2 (HCS12 Interrupt)

Address	Name	Bit 7	Bit 6	Bit 5	Bit 4	Bit 3	Bit 2	Bit 1	Bit 0
\$001F	HPRIO	Read: PSEL7	PSEL6	PSEL5	PSEL4	PSEL3	PSEL2	PSEL1	0
		Write:							

\$0020 - \$002F
DBG (including BKP) map 1of 1 (HCS12 Debug)

Address	Name	Bit 7	Bit 6	Bit 5	Bit 4	Bit 3	Bit 2	Bit 1	Bit 0	
\$0020	DBGC1 -	read	DBGEN	ARM	TRGSEL	BEGIN	DBGBRK	0	CAPMOD	
		write								
\$0021	DBGSC -	read	AF	BF	CF	0	TRG			
		write								
\$0022	DBGTBH -	read	Bit 15	Bit 14	Bit 13	Bit 12	Bit 11	Bit 10	Bit 9	Bit 8
		write								
\$0023	DBGTBL -	read	Bit 7	Bit 6	Bit 5	Bit 4	Bit 3	Bit 2	Bit 1	Bit 0
		write								
\$0024	DBGCNT -	read	TBF	0	CNT					
		write								
\$0025	DBGCCX -	read	PAGSEL			EXTCMP				
		write								
\$0026	DBGCCH	read	Bit 15	14	13	12	11	10	9	Bit 8
		write								
\$0027	DBGCCL -	read	Bit 7	6	5	4	3	2	1	Bit 0
		write								
\$0028	DBGC2 BKPCT0	read	BKABEN	FULL	BDM	TAGAB	BKCEN	TAGC	RWCEN	RWC
		write								
\$0029	DBGC3 BKPCT1	read	BKAMBH	BKAMBL	BKBMBH	BKBMBL	RWAEN	RWA	RWBEN	RWB
		write								
\$002A	DBGCAH BKP0X	read	PAGSEL			EXTCMP				
		write								
\$002B	DBGCAH BKP0H	read	Bit 15	14	13	12	11	10	9	Bit 8
		write								

\$0020 - \$002F

DBG (including BKP) map 1of 1 (HCS12 Debug)

Address	Name		Bit 7	Bit 6	Bit 5	Bit 4	Bit 3	Bit 2	Bit 1	Bit 0
\$002C	DBGCAL BKP0L	read write	Bit 7	6	5	4	3	2	1	Bit 0
\$002D	DBGCBX BKP1X	read write	PAGSEL			EXTCMP				
\$002E	DBGCBH BKP1H	read write	Bit 15	14	13	12	11	10	9	Bit 8
\$002F	DBGCBL BKP1L	read write	Bit 7	6	5	4	3	2	1	Bit 0

\$0030 - \$0031

MMC map 4 of 4 (HCS12 Module Mapping Control)

Address	Name		Bit 7	Bit 6	Bit 5	Bit 4	Bit 3	Bit 2	Bit 1	Bit 0
\$0030	PPAGE	Read: Write:	0	0	PIX5	PIX4	PIX3	PIX2	PIX1	PIX0
\$0031	Reserved	Read: Write:	0	0	0	0	0	0	0	0

\$0032 - \$0033

MEBI map 3 of 3 (HCS12 Multiplexed External Bus Interface)

Address	Name		Bit 7	Bit 6	Bit 5	Bit 4	Bit 3	Bit 2	Bit 1	Bit 0
\$0032	PORTK	Read: Write:	Bit 7	6	5	4	3	2	1	Bit 0
\$0033	DDRK	Read: Write:	Bit 7	6	5	4	3	2	1	Bit 0

\$0034 - \$003F

CRG (Clock and Reset Generator)

Address	Name		Bit 7	Bit 6	Bit 5	Bit 4	Bit 3	Bit 2	Bit 1	Bit 0
\$0034	SYNR	Read: Write:	0	0	SYN5	SYN4	SYN3	SYN2	SYN1	SYN0
\$0035	REFDV	Read: Write:	0	0	0	0	REFDV3	REFDV2	REFDV1	REFDV0
\$0036	CTFLG TEST ONLY	Read: Write:	TOUT7	TOUT6	TOUT5	TOUT4	TOUT3	TOUT2	TOUT1	TOUT0
\$0037	CRGFLG	Read: Write:	RTIF	PROF	0	LOCKIF	LOCK	TRACK	SCMIF	SCM
\$0038	CRGINT	Read: Write:	RTIE	0	0	LOCKIE	0	0	SCMIE	0
\$0039	CLKSEL	Read: Write:	PLLSEL	PSTP	SYSWAI	ROAWAI	PLLWAI	CWAI	RTIWAI	COPWAI
\$003A	PLLCTL	Read: Write:	CME	PLLON	AUTO	ACQ	0	PRE	PCE	SCME
\$003B	RTICTL	Read: Write:	0	RTR6	RTR5	RTR4	RTR3	RTR2	RTR1	RTR0
\$003C	COPCTL	Read: Write:	WCOP	RSBCK	0	0	0	CR2	CR1	CR0

\$0034 - \$003F**CRG (Clock and Reset Generator)**

Address	Name		Bit 7	Bit 6	Bit 5	Bit 4	Bit 3	Bit 2	Bit 1	Bit 0
\$003D	FORBYP TEST ONLY	Read:	RTIBYP	COPBYP	0	PLLBYP	0	0	FCM	0
		Write:								
\$003E	CTCTL TEST ONLY	Read:	TCTL7	TCTL6	TCTL5	TCTL4	TCTL3	TCTL2	TCTL1	TCTL0
		Write:								
\$003F	ARMCOP	Read:	0	0	0	0	0	0	0	0
		Write:	Bit 7	6	5	4	3	2	1	Bit 0

\$0040 - \$006F**TIM (Timer 16 Bit 8 Channels)**

Address	Name		Bit 7	Bit 6	Bit 5	Bit 4	Bit 3	Bit 2	Bit 1	Bit 0
\$0040	TIOS	Read:	IOS7	IOS6	IOS5	IOS4	IOS3	IOS2	IOS1	IOS0
		Write:								
\$0041	CFORC	Read:	0	0	0	0	0	0	0	0
		Write:	FOC7	FOC6	FOC5	FOC4	FOC3	FOC2	FOC1	FOC0
\$0042	OC7M	Read:	OC7M7	OC7M6	OC7M5	OC7M4	OC7M3	OC7M2	OC7M1	OC7M0
		Write:								
\$0043	OC7D	Read:	OC7D7	OC7D6	OC7D5	OC7D4	OC7D3	OC7D2	OC7D1	OC7D0
		Write:								
\$0044	TCNT (hi)	Read:	Bit 15	14	13	12	11	10	9	Bit 8
		Write:								
\$0045	TCNT (lo)	Read:	Bit 7	6	5	4	3	2	1	Bit 0
		Write:								
\$0046	TSCR1	Read:	TEN	TSWAI	TSFRZ	TFFCA	0	0	0	0
		Write:								
\$0047	TTOV	Read:	TOV7	TOV6	TOV5	TOV4	TOV3	TOV2	TOV1	TOV0
		Write:								
\$0048	TCTL1	Read:	OM7	OL7	OM6	OL6	OM5	OL5	OM4	OL4
		Write:								
\$0049	TCTL2	Read:	OM3	OL3	OM2	OL2	OM1	OL1	OM0	OL0
		Write:								
\$004A	TCTL3	Read:	EDG7B	EDG7A	EDG6B	EDG6A	EDG5B	EDG5A	EDG4B	EDG4A
		Write:								
\$004B	TCTL4	Read:	EDG3B	EDG3A	EDG2B	EDG2A	EDG1B	EDG1A	EDG0B	EDG0A
		Write:								
\$004C	TIE	Read:	C7I	C6I	C5I	C4I	C3I	C2I	C1I	C0I
		Write:								
\$004D	TSCR2	Read:	TOI	0	0	0	TCRE	PR2	PR1	PR0
		Write:								
\$004E	TFLG1	Read:	C7F	C6F	C5F	C4F	C3F	C2F	C1F	C0F
		Write:								
\$004F	TFLG2	Read:	TOF	0	0	0	0	0	0	0
		Write:								
\$0050	TC0 (hi)	Read:	Bit 15	14	13	12	11	10	9	Bit 8
		Write:								
\$0051	TC0 (lo)	Read:	Bit 7	6	5	4	3	2	1	Bit 0
		Write:								
\$0052	TC1 (hi)	Read:	Bit 15	14	13	12	11	10	9	Bit 8
		Write:								
\$0053	TC1 (lo)	Read:	Bit 7	6	5	4	3	2	1	Bit 0
		Write:								

\$0040 - \$006F

TIM (Timer 16 Bit 8 Channels)

Address	Name		Bit 7	Bit 6	Bit 5	Bit 4	Bit 3	Bit 2	Bit 1	Bit 0
\$0054	TC2 (hi)	Read: Write:	Bit 15	14	13	12	11	10	9	Bit 8
\$0055	TC2 (lo)	Read: Write:	Bit 7	6	5	4	3	2	1	Bit 0
\$0056	TC3 (hi)	Read: Write:	Bit 15	14	13	12	11	10	9	Bit 8
\$0057	TC3 (lo)	Read: Write:	Bit 7	6	5	4	3	2	1	Bit 0
\$0058	TC4 (hi)	Read: Write:	Bit 15	14	13	12	11	10	9	Bit 8
\$0059	TC4 (lo)	Read: Write:	Bit 7	6	5	4	3	2	1	Bit 0
\$005A	TC5 (hi)	Read: Write:	Bit 15	14	13	12	11	10	9	Bit 8
\$005B	TC5 (lo)	Read: Write:	Bit 7	6	5	4	3	2	1	Bit 0
\$005C	TC6 (hi)	Read: Write:	Bit 15	14	13	12	11	10	9	Bit 8
\$005D	TC6 (lo)	Read: Write:	Bit 7	6	5	4	3	2	1	Bit 0
\$005E	TC7 (hi)	Read: Write:	Bit 15	14	13	12	11	10	9	Bit 8
\$005F	TC7 (lo)	Read: Write:	Bit 7	6	5	4	3	2	1	Bit 0
\$0060	PACTL	Read: Write:	0	PAEN	PAMOD	PEDGE	CLK1	CLK0	PAOVI	PAI
\$0061	PAFLG	Read: Write:	0	0	0	0	0	0	PAOVF	PAIF
\$0062	PACNT (hi)	Read: Write:	Bit 7	6	5	4	3	2	1	Bit 0
\$0063	PACNT (lo)	Read: Write:	Bit 7	6	5	4	3	2	1	Bit 0
\$0064	Reserved	Read: Write:	0	0	0	0	0	0	0	0
\$0065	Reserved	Read: Write:	0	0	0	0	0	0	0	0
\$0066	Reserved	Read: Write:	0	0	0	0	0	0	0	0
\$0067	Reserved	Read: Write:	0	0	0	0	0	0	0	0
\$0068	Reserved	Read: Write:	0	0	0	0	0	0	0	0
\$0069	Reserved	Read: Write:	0	0	0	0	0	0	0	0
\$006A	Reserved	Read: Write:	0	0	0	0	0	0	0	0
\$006B	Reserved	Read: Write:	0	0	0	0	0	0	0	0
\$006C	Reserved	Read: Write:	0	0	0	0	0	0	0	0

\$0040 - \$006F
TIM (Timer 16 Bit 8 Channels)

Address	Name		Bit 7	Bit 6	Bit 5	Bit 4	Bit 3	Bit 2	Bit 1	Bit 0
\$006D	Reserved	Read:	0	0	0	0	0	0	0	0
		Write:								
\$006E	Reserved	Read:	0	0	0	0	0	0	0	0
		Write:								
\$006F	Reserved	Read:	0	0	0	0	0	0	0	0
		Write:								

\$0070 - \$007F
Reserved space

Address	Name		Bit 7	Bit 6	Bit 5	Bit 4	Bit 3	Bit 2	Bit 1	Bit 0
\$0070 - \$007F	Reserved	Read:	0	0	0	0	0	0	0	0
		Write:								

\$0080 - \$00AF
ATD (Analog to Digital Converter 10 Bit 16 Channel)¹

Address	Name		Bit 7	Bit 6	Bit 5	Bit 4	Bit 3	Bit 2	Bit 1	Bit 0
\$0080	ATDCTL0	Read:	0	0	0	0	WRAP3	WRAP2	WRAP1	WRAP0
		Write:								
\$0081	ATDCTL1	Read:	ETRIGSEL	0	0	0	ETRIGCH3	ETRIGCH2	ETRIGCH1	ETRIGCH0
		Write:								
\$0082	ATDCTL2	Read:	ADPU	AFFC	AWAI	ETRIGLE	ETRIGP	ETRIG	ASCIE	ASCIF
		Write:								
\$0083	ATDCTL3	Read:	0	S8C	S4C	S2C	S1C	FIFO	FRZ1	FRZ0
		Write:								
\$0084	ATDCTL4	Read:	SRES8	SMP1	SMP0	PRS4	PRS3	PRS2	PRS1	PRS0
		Write:								
\$0085	ATDCTL5	Read:	DJM	DSGN	SCAN	MULT	0	CC	CB	CA
		Write:								
\$0086	ATDSTAT0	Read:	SCF	0	ETORF	FIFOR	0	CC2	CC1	CC0
		Write:								
\$0087	Reserved	Read:	0	0	0	0	0	0	0	0
		Write:								
\$0088	ATDTEST0	Read:	0	0	0	0	0	0	0	0
		Write:								
\$0089	ATDTEST1	Read:	0	0	0	0	0	0	0	SC
		Write:								
\$008A	ATDSTAT0	Read:	CCF15	CCF14	CCF13	CCF12	CCF11	CCF10	CCF9	CCF8
		Write:								
\$008B	ATDSTAT1	Read:	CCF7	CCF6	CCF5	CCF4	CCF3	CCF2	CCF1	CCF0
		Write:								
\$008C	ATDDIEN1	Read:	IEN15	IEN14	IEN13	IEN12	IEN11	IEN10	IEN9	IEN8
		Write:								
\$008D	ATDDIEN0	Read:	IEN7	IEN6	IEN5	IEN4	IEN3	IEN2	IEN1	IEN0
		Write:								
\$008E	PORTAD1	Read:	PTAD15	PTAD14	PTAD13	PTAD12	PTAD11	PTAD10	PTAD9	PTAD8
		Write:								
\$008F	PORTAD0	Read:	PTAD7	PTAD6	PTAD5	PTAD4	PTAD3	PTAD2	PTAD1	PTAD0
		Write:								

\$0080 - \$00AF

ATD (Analog to Digital Converter 10 Bit 16 Channel)¹

Address	Name		Bit 7	Bit 6	Bit 5	Bit 4	Bit 3	Bit 2	Bit 1	Bit 0
\$0090	ATDDR0H	Read:	Bit15	14	13	12	11	10	9	Bit8
		Write:								
\$0091	ATDDR0L	Read:	Bit7	Bit6	0	0	0	0	0	0
		Write:								
\$0092	ATDDR1H	Read:	Bit15	14	13	12	11	10	9	Bit8
		Write:								
\$0093	ATDDR1L	Read:	Bit7	Bit6	0	0	0	0	0	0
		Write:								
\$0094	ATDDR2H	Read:	Bit15	14	13	12	11	10	9	Bit8
		Write:								
\$0095	ATDDR2L	Read:	Bit7	Bit6	0	0	0	0	0	0
		Write:								
\$0096	ATDDR3H	Read:	Bit15	14	13	12	11	10	9	Bit8
		Write:								
\$0097	ATDDR3L	Read:	Bit7	Bit6	0	0	0	0	0	0
		Write:								
\$0098	ATDDR4H	Read:	Bit15	14	13	12	11	10	9	Bit8
		Write:								
\$0099	ATDDR4L	Read:	Bit7	Bit6	0	0	0	0	0	0
		Write:								
\$009A	ATDDR5H	Read:	Bit15	14	13	12	11	10	9	Bit8
		Write:								
\$009B	ATDDR5L	Read:	Bit7	Bit6	0	0	0	0	0	0
		Write:								
\$009C	ATDDR6H	Read:	Bit15	14	13	12	11	10	9	Bit8
		Write:								
\$009D	ATDDR6L	Read:	Bit7	Bit6	0	0	0	0	0	0
		Write:								
\$009E	ATDDR7H	Read:	Bit15	14	13	12	11	10	9	Bit8
		Write:								
\$009F	ATDDR7L	Read:	Bit7	Bit6	0	0	0	0	0	0
		Write:								
\$00A0	ATDDR8H	Read:	Bit15	14	13	12	11	10	9	Bit8
		Write:								
\$00A1	ATDDR8L	Read:	Bit7	Bit6	0	0	0	0	0	0
		Write:								
\$00A2	ATDDR9H	Read:	Bit15	14	13	12	11	10	9	Bit8
		Write:								
\$00A3	ATDDR9L	Read:	Bit7	Bit6	0	0	0	0	0	0
		Write:								
\$00A4	ATDDR10H	Read:	Bit15	14	13	12	11	10	9	Bit8
		Write:								
\$00A5	ATDDR10L	Read:	Bit7	Bit6	0	0	0	0	0	0
		Write:								
\$00A6	ATDDR11H	Read:	Bit15	14	13	12	11	10	9	Bit8
		Write:								
\$00A7	ATDDR11L	Read:	Bit7	Bit6	0	0	0	0	0	0
		Write:								
\$00A8	ATDDR12H	Read:	Bit15	14	13	12	11	10	9	Bit8
		Write:								

\$0080 - \$00AF**ATD (Analog to Digital Converter 10 Bit 16 Channel)¹**

Address	Name		Bit 7	Bit 6	Bit 5	Bit 4	Bit 3	Bit 2	Bit 1	Bit 0
\$00A9	ATDDR12L	Read:	Bit7	Bit6	0	0	0	0	0	0
		Write:								
\$00AA	ATDDR13H	Read:	Bit15	14	13	12	11	10	9	Bit8
		Write:								
\$00AB	ATDDR13L	Read:	Bit7	Bit6	0	0	0	0	0	0
		Write:								
\$00AC	ATDDR14H	Read:	Bit15	14	13	12	11	10	9	Bit8
		Write:								
\$00AD	ATDDR14L	Read:	Bit7	Bit6	0	0	0	0	0	0
		Write:								
\$00AE	ATDDR15H	Read:	Bit15	14	13	12	11	10	9	Bit8
		Write:								
\$00AF	ATDDR15L	Read:	Bit7	Bit6	0	0	0	0	0	0
		Write:								

NOTES:

1. Registers only available on MC9S12KG128(64)(32), MC9S12KL128(64) and MC9S12KC128(64)

\$00B0 - \$00C7**Reserved space¹**

Address	Name		Bit 7	Bit 6	Bit 5	Bit 4	Bit 3	Bit 2	Bit 1	Bit 0
\$00B0 - \$00C7	Reserved	Read:	0	0	0	0	0	0	0	0
		Write:								

NOTES:

1. Reserved space for MC9S12KG128(64)(32), MC9S12KL128(64) and MC9S12KC128(64)

\$0080 - \$009F**ATD0 (Analog to Digital Converter 10 Bit 8 Channel)¹**

Address	Name		Bit 7	Bit 6	Bit 5	Bit 4	Bit 3	Bit 2	Bit 1	Bit 0
\$0080	ATD0CTL0	Read:	0	0	0	0	0	WRAP2	WRAP1	WRAP0
		Write:								
\$0081	ATD0CTL1	Read:	ETRIGSEL	0	0	0	0	ETRIGCH2	ETRIGCH1	ETRIGCH0
		Write:								
\$0082	ATD0CTL2	Read:	ADPU	AFFC	AWAI	ETRIGLE	ETRIGP	ETRIG	ASCIE	ASCIF
		Write:								
\$0083	ATD0CTL3	Read:	0	S8C	S4C	S2C	S1C	FIFO	FRZ1	FRZ0
		Write:								
\$0084	ATD0CTL4	Read:	SRES8	SMP1	SMP0	PRS4	PRS3	PRS2	PRS1	PRS0
		Write:								
\$0085	ATD0CTL5	Read:	DJM	DSGN	SCAN	MULT	0	CC	CB	CA
		Write:								
\$0086	ATD0STAT0	Read:	SCF	0	ETORF	FIFOR	0	CC2	CC1	CC0
		Write:								
\$0087	Reserved	Read:	0	0	0	0	0	0	0	0
		Write:								
\$0088	ATD0TEST0	Read:	0	0	0	0	0	0	0	0
		Write:								
\$0089	ATD0TEST1	Read:	0	0	0	0	0	0	0	SC
		Write:								

\$0080 - \$009F

ATD0 (Analog to Digital Converter 10 Bit 8 Channel)¹

Address	Name		Bit 7	Bit 6	Bit 5	Bit 4	Bit 3	Bit 2	Bit 1	Bit 0
\$008A	Reserved	Read:	0	0	0	0	0	0	0	0
		Write:								
\$008B	ATD0STAT1	Read:	CCF7	CCF6	CCF5	CCF4	CCF3	CCF2	CCF1	CCF0
		Write:								
\$008C	Reserved	Read:	0	0	0	0	0	0	0	0
		Write:								
\$008D	ATD0DIEN	Read:	IEN7	IEN6	IEN5	IEN4	IEN3	IEN2	IEN1	IEN0
		Write:								
\$008E	Reserved	Read:	0	0	0	0	0	0	0	0
		Write:								
\$008F	PORTAD0	Read:	PTAD7	PTAD6	PTAD5	PTAD4	PTAD3	PTAD2	PTAD1	PTAD0
		Write:								
\$0090	ATD0DR0H	Read:	Bit15	14	13	12	11	10	9	Bit8
		Write:								
\$0091	ATD0DR0L	Read:	Bit7	Bit6	0	0	0	0	0	0
		Write:								
\$0092	ATD0DR1H	Read:	Bit15	14	13	12	11	10	9	Bit8
		Write:								
\$0093	ATD0DR1L	Read:	Bit7	Bit6	0	0	0	0	0	0
		Write:								
\$0094	ATD0DR2H	Read:	Bit15	14	13	12	11	10	9	Bit8
		Write:								
\$0095	ATD0DR2L	Read:	Bit7	Bit6	0	0	0	0	0	0
		Write:								
\$0096	ATD0DR3H	Read:	Bit15	14	13	12	11	10	9	Bit8
		Write:								
\$0097	ATD0DR3L	Read:	Bit7	Bit6	0	0	0	0	0	0
		Write:								
\$0098	ATD0DR4H	Read:	Bit15	14	13	12	11	10	9	Bit8
		Write:								
\$0099	ATD0DR4L	Read:	Bit7	Bit6	0	0	0	0	0	0
		Write:								
\$009A	ATD0DR5H	Read:	Bit15	14	13	12	11	10	9	Bit8
		Write:								
\$009B	ATD0DR5L	Read:	Bit7	Bit6	0	0	0	0	0	0
		Write:								
\$009C	ATD0DR6H	Read:	Bit15	14	13	12	11	10	9	Bit8
		Write:								
\$009D	ATD0DR6L	Read:	Bit7	Bit6	0	0	0	0	0	0
		Write:								
\$009E	ATD0DR7H	Read:	Bit15	14	13	12	11	10	9	Bit8
		Write:								
\$009F	ATD0DR7L	Read:	Bit7	Bit6	0	0	0	0	0	0
		Write:								

NOTES:

1. Registers only available on MC9S12KT256 and MC9S12KG256

\$00A0 - \$00C7**Reserved space¹**

Address	Name	Bit 7	Bit 6	Bit 5	Bit 4	Bit 3	Bit 2	Bit 1	Bit 0
\$00A0	Reserved	0	0	0	0	0	0	0	0
- \$00C7									

NOTES:

1. Reserved space for MC9S12KT256 and MC9S12KG256

\$00C8 - \$00CF**SCI0 (Asynchronous Serial Interface)**

Address	Name	Bit 7	Bit 6	Bit 5	Bit 4	Bit 3	Bit 2	Bit 1	Bit 0
\$00C8	SCI0BDH	Read: 0	0	0	SBR12	SBR11	SBR10	SBR9	SBR8
		Write:							
\$00C9	SCI0BDL	Read: SBR7	SBR6	SBR5	SBR4	SBR3	SBR2	SBR1	SBR0
		Write:							
\$00CA	SCI0CR1	Read: LOOPS	SCISWAI	RSRC	M	WAKE	ILT	PE	PT
		Write:							
\$00CB	SCI0CR2	Read: TIE	TCIE	RIE	ILIE	TE	RE	RWU	SBK
		Write:							
\$00CC	SCI0SR1	Read: TDRE	TC	RDRF	IDLE	OR	NF	FE	PF
		Write:							
\$00CD	SCI0SR2	Read: 0	0	0	0	0	BRK13	TXDIR	RAF
		Write:							
\$00CE	SCI0DRH	Read: R8	T8	0	0	0	0	0	0
		Write:							
\$00CF	SCI0DRL	Read: R7	R6	R5	R4	R3	R2	R1	R0
		Write: T7	T6	T5	T4	T3	T2	T1	T0

\$00D0 - \$00D7**SCI1 (Asynchronous Serial Interface)**

Address	Name	Bit 7	Bit 6	Bit 5	Bit 4	Bit 3	Bit 2	Bit 1	Bit 0
\$00D0	SCI1BDH	Read: 0	0	0	SBR12	SBR11	SBR10	SBR9	SBR8
		Write:							
\$00D1	SCI1BDL	Read: SBR7	SBR6	SBR5	SBR4	SBR3	SBR2	SBR1	SBR0
		Write:							
\$00D2	SCI1CR1	Read: LOOPS	SCISWAI	RSRC	M	WAKE	ILT	PE	PT
		Write:							
\$00D3	SCI1CR2	Read: TIE	TCIE	RIE	ILIE	TE	RE	RWU	SBK
		Write:							
\$00D4	SCI1SR1	Read: TDRE	TC	RDRF	IDLE	OR	NF	FE	PF
		Write:							
\$00D5	SCI1SR2	Read: 0	0	0	0	0	BRK13	TXDIR	RAF
		Write:							
\$00D6	SCI1DRH	Read: R8	T8	0	0	0	0	0	0
		Write:							
\$00D7	SCI1DRL	Read: R7	R6	R5	R4	R3	R2	R1	R0
		Write: T7	T6	T5	T4	T3	T2	T1	T0

\$00D8 - \$00DF

SPI0 (Serial Peripheral Interface)

Address	Name		Bit 7	Bit 6	Bit 5	Bit 4	Bit 3	Bit 2	Bit 1	Bit 0
\$00D8	SPI0CR1	Read:	SPIE	SPE	SPTIE	MSTR	CPOL	CPHA	SSOE	LSBFE
		Write:								
\$00D9	SPI0CR2	Read:	0	0	0	MODFEN	BIDIROE	0	SPISWAI	SPC0
		Write:								
\$00DA	SPI0BR	Read:	0	SPPR2	SPPR1	SPPR0	0	SPR2	SPR1	SPR0
		Write:								
\$00DB	SPI0SR	Read:	SPIF	0	SPTEF	MODF	0	0	0	0
		Write:								
\$00DC	Reserved	Read:	0	0	0	0	0	0	0	0
		Write:								
\$00DD	SPI0DR	Read:	Bit7	6	5	4	3	2	1	Bit0
		Write:								
\$00DE	Reserved	Read:	0	0	0	0	0	0	0	0
		Write:								
\$00DF	Reserved	Read:	0	0	0	0	0	0	0	0
		Write:								

\$00E0 - \$00E7

IIC (Inter IC Bus)

Address	Name		Bit 7	Bit 6	Bit 5	Bit 4	Bit 3	Bit 2	Bit 1	Bit 0
\$00E0	IBAD	Read:	ADR7	ADR6	ADR5	ADR4	ADR3	ADR2	ADR1	0
		Write:								
\$00E1	IBFD	Read:	IBC7	IBC6	IBC5	IBC4	IBC3	IBC2	IBC1	IBC0
		Write:								
\$00E2	IBCR	Read:	IBEN	IBIE	MS/SL	TX/RX	TXAK	0	0	IBSWAI
		Write:						RSTA		
\$00E3	IBSR	Read:	TCF	IAAS	IBB	IBAL	0	SRW	IBIF	RXAK
		Write:								
\$00E4	IBDR	Read:	D7	D6	D5	D4	D3	D2	D1	D0
		Write:								
\$00E5	Reserved	Read:	0	0	0	0	0	0	0	0
		Write:								
\$00E6	Reserved	Read:	0	0	0	0	0	0	0	0
		Write:								
\$00E7	Reserved	Read:	0	0	0	0	0	0	0	0
		Write:								

\$00E8 - \$00EF

Reserved space

Address	Name		Bit 7	Bit 6	Bit 5	Bit 4	Bit 3	Bit 2	Bit 1	Bit 0
\$00E8 - \$00EF	Reserved	Read:	0	0	0	0	0	0	0	0
		Write:								

\$00F0 - \$00F7**SPI1 (Serial Peripheral Interface)**

Address	Name		Bit 7	Bit 6	Bit 5	Bit 4	Bit 3	Bit 2	Bit 1	Bit 0
\$00F0	SPI1CR1	Read:	SPIE	SPE	SPTIE	MSTR	CPOL	CPHA	SSOE	LSBFE
		Write:								
\$00F1	SPI1CR2	Read:	0	0	0	MODFEN	BIDIROE	0	SPISWAI	SPC0
		Write:								
\$00F2	SPI1BR	Read:	0	SPPR2	SPPR1	SPPR0	0	SPR2	SPR1	SPR0
		Write:								
\$00F3	SPI1SR	Read:	SPIF	0	SPTEF	MODF	0	0	0	0
		Write:								
\$00F4	Reserved	Read:	0	0	0	0	0	0	0	0
		Write:								
\$00F5	SPI1DR	Read:	Bit7	6	5	4	3	2	1	Bit0
		Write:								
\$00F6	Reserved	Read:	0	0	0	0	0	0	0	0
		Write:								
\$00F7	Reserved	Read:	0	0	0	0	0	0	0	0
		Write:								

\$00F8 - \$00FF**SPI2 (Serial Peripheral Interface)**

Address	Name		Bit 7	Bit 6	Bit 5	Bit 4	Bit 3	Bit 2	Bit 1	Bit 0
\$00F8	SPI2CR1	Read:	SPIE	SPE	SPTIE	MSTR	CPOL	CPHA	SSOE	LSBFE
		Write:								
\$00F9	SPI2CR2	Read:	0	0	0	MODFEN	BIDIROE	0	SPISWAI	SPC0
		Write:								
\$00FA	SPI2BR	Read:	0	SPPR2	SPPR1	SPPR0	0	SPR2	SPR1	SPR0
		Write:								
\$00FB	SPI2SR	Read:	SPIF	0	SPTEF	MODF	0	0	0	0
		Write:								
\$00FC	Reserved	Read:	0	0	0	0	0	0	0	0
		Write:								
\$00FD	SPI2DR	Read:	Bit7	6	5	4	3	2	1	Bit0
		Write:								
\$00FE	Reserved	Read:	0	0	0	0	0	0	0	0
		Write:								
\$00FF	Reserved	Read:	0	0	0	0	0	0	0	0
		Write:								

\$0100 - \$010F**Flash Control Register**

Address	Name		Bit 7	Bit 6	Bit 5	Bit 4	Bit 3	Bit 2	Bit 1	Bit 0
\$0100	FCLKDIV	Read:	FDIVLD	PRDIV8	FDIV5	FDIV4	FDIV3	FDIV2	FDIV1	FDIV0
		Write:								
\$0101	FSEC	Read:	KEYEN		RNV5	RNV4	RNV3	RNV2	SEC	
		Write:								
\$0102	FTSTMOD	Read:	0	0	0	WRALL ¹	DFD	0	0	0
		Write:								
\$0103	FCNFG	Read:	CBEIE	CCIE	KEYACC	0	DFDIE	0	0	BKSEL ⁽¹⁾
		Write:								

\$0100 - \$010F

Flash Control Register

Address	Name		Bit 7	Bit 6	Bit 5	Bit 4	Bit 3	Bit 2	Bit 1	Bit 0
\$0104	FPROT	Read:	FPOPEN	RNV6	FPHDIS	FPHS		FPLDIS	FPLS	
		Write:								
\$0105	FSTAT	Read:	CBEIF	CCIF	PVIOL	ACCERR	DFDIF	BLANK	0	0
		Write:								
\$0106	FCMD	Read:	0	CMDB						
		Write:								
\$0107	FCTL ²	Read:	NV7	NV6	NV5	NV4	NV3	NV2	NV1	NV0
		Write:								
\$0108	FADDRHI	Read:	FADDRHI							
		Write:								
\$0109	FADDRLO	Read:	FADDRLO							
		Write:								
\$010A	FDATAHI	Read:	FDATAHI							
		Write:								
\$010B	FDATALO	Read:	FDATALO							
		Write:								
\$010C	Reserved	Read:	0	0	0	0	0	0	0	0
		Write:								
\$010D	Reserved	Read:	0	0	0	0	0	0	0	0
		Write:								
\$010E	Reserved	Read:	0	0	0	0	0	0	0	0
		Write:								
\$010F	Reserved	Read:	0	0	0	0	0	0	0	0
		Write:								

NOTES:

1. Bit only available on MC9S12KT256 and MC9S12KG256.
2. Register only available on MC9S12KT256 and MC9S12KG256.

\$0110 - \$011B

EEPROM Control Register

Address	Name		Bit 7	Bit 6	Bit 5	Bit 4	Bit 3	Bit 2	Bit 1	Bit 0
\$0110	ECLKDIV	Read:	EDIVLD	PRDIV8	EDIV5	EDIV4	EDIV3	EDIV2	EDIV1	EDIV0
		Write:								
\$0111	Reserved	Read:	0	0	0	0	0	0	0	0
		Write:								
\$0112	Reserved for Factory Test	Read:	0	0	0	0	0	0	0	0
		Write:								
\$0113	ECNFG	Read:	CBEIE	CCIE	0	0	0	0	0	0
		Write:								
\$0114	EPROT	Read:	EPOPEN	NV6	NV5	NV4	EPDIS	EP2	EP1	EP0
		Write:								
\$0115	ESTAT	Read:	CBEIF	CCIF	PVIOL	ACCERR	0	BLANK	0	0
		Write:								
\$0116	ECMD	Read:	0	CMDB6	CMDB5	0	0	CMDB2	0	CMDB0
		Write:								
\$0117	Reserved for Factory Test	Read:	0	0	0	0	0	0	0	0
		Write:								
\$0118	EADDRHI	Read:	0	0	0	0	0	10	9	Bit 8
		Write:								

\$0110 - \$011B**EEPROM Control Register**

Address	Name		Bit 7	Bit 6	Bit 5	Bit 4	Bit 3	Bit 2	Bit 1	Bit 0
\$0119	EADDRLO	Read:	Bit 7	6	5	4	3	2	1	Bit 0
		Write:								
\$011A	EDATAHI	Read:	Bit 15	14	13	12	11	10	9	Bit 8
		Write:								
\$011B	EDATALO	Read:	Bit 7	6	5	4	3	2	1	Bit 0
		Write:								

\$011C - \$011F**Reserved space**

Address	Name		Bit 7	Bit 6	Bit 5	Bit 4	Bit 3	Bit 2	Bit 1	Bit 0
\$011C - \$011F	Reserved	Read:	0	0	0	0	0	0	0	0
		Write:								

\$0120 - \$013F**ATD1 (Analog to Digital Converter 10 Bit 8 Channel)¹**

Address	Name		Bit 7	Bit 6	Bit 5	Bit 4	Bit 3	Bit 2	Bit 1	Bit 0
\$0120	ATD1CTL0	Read:	0	0	0	0	0	WRAP2	WRAP1	WRAP0
		Write:								
\$0121	ATD1CTL1	Read:	ETRIGSEL	0	0	0	0	ETRIGCH2	ETRIGCH1	ETRIGCH0
		Write:								
\$0122	ATD1CTL2	Read:	ADPU	AFFC	AWAI	ETRIGLE	ETRIGP	ETRIG	ASCIE	ASCIF
		Write:								
\$0123	ATD1CTL3	Read:	0	S8C	S4C	S2C	S1C	FIFO	FRZ1	FRZ0
		Write:								
\$0124	ATD1CTL4	Read:	SRES8	SMP1	SMP0	PRS4	PRS3	PRS2	PRS1	PRS0
		Write:								
\$0125	ATD1CTL5	Read:	DJM	DSGN	SCAN	MULT	0	CC	CB	CA
		Write:								
\$0126	ATD1STAT0	Read:	SCF	0	ETORF	FIFOR	0	CC2	CC1	CC0
		Write:								
\$0127	Reserved	Read:	0	0	0	0	0	0	0	0
		Write:								
\$0128	ATD1TEST0	Read:	0	0	0	0	0	0	0	0
		Write:								
\$0129	ATD1TEST1	Read:	0	0	0	0	0	0	0	SC
		Write:								
\$012A	Reserved	Read:	0	0	0	0	0	0	0	0
		Write:								
\$012B	ATD1STAT1	Read:	CCF7	CCF6	CCF5	CCF4	CCF3	CCF2	CCF1	CCF0
		Write:								
\$012C	Reserved	Read:	0	0	0	0	0	0	0	0
		Write:								
\$012D	ATD1DIEN	Read:	IEN7	IEN6	IEN5	IEN4	IEN3	IEN2	IEN1	IEN0
		Write:								
\$012E	Reserved	Read:	0	0	0	0	0	0	0	0
		Write:								
\$012F	PORTAD1	Read:	PTAD7	PTAD6	PTAD5	PTAD4	PTAD3	PTAD2	PTAD1	PTAD0
		Write:								

\$0120 - \$013F

ATD1 (Analog to Digital Converter 10 Bit 8 Channel)¹

Address	Name		Bit 7	Bit 6	Bit 5	Bit 4	Bit 3	Bit 2	Bit 1	Bit 0
\$0130	ATD1DR0H	Read:	Bit15	14	13	12	11	10	9	Bit8
		Write:								
\$0131	ATD1DR0L	Read:	Bit7	Bit6	0	0	0	0	0	0
		Write:								
\$0132	ATD1DR1H	Read:	Bit15	14	13	12	11	10	9	Bit8
		Write:								
\$0133	ATD1DR1L	Read:	Bit7	Bit6	0	0	0	0	0	0
		Write:								
\$0134	ATD1DR2H	Read:	Bit15	14	13	12	11	10	9	Bit8
		Write:								
\$0135	ATD1DR2L	Read:	Bit7	Bit6	0	0	0	0	0	0
		Write:								
\$0136	ATD1DR3H	Read:	Bit15	14	13	12	11	10	9	Bit8
		Write:								
\$0137	ATD1DR3L	Read:	Bit7	Bit6	0	0	0	0	0	0
		Write:								
\$0138	ATD1DR4H	Read:	Bit15	14	13	12	11	10	9	Bit8
		Write:								
\$0139	ATD1DR4L	Read:	Bit7	Bit6	0	0	0	0	0	0
		Write:								
\$013A	ATD1DR5H	Read:	Bit15	14	13	12	11	10	9	Bit8
		Write:								
\$013B	ATD1DR5L	Read:	Bit7	Bit6	0	0	0	0	0	0
		Write:								
\$013C	ATD1DR6H	Read:	Bit15	14	13	12	11	10	9	Bit8
		Write:								
\$013D	ATD1DR6L	Read:	Bit7	Bit6	0	0	0	0	0	0
		Write:								
\$013E	ATD1DR7H	Read:	Bit15	14	13	12	11	10	9	Bit8
		Write:								
\$013F	ATD1DR7L	Read:	Bit7	Bit6	0	0	0	0	0	0
		Write:								

NOTES:

1. Registers only available on MC9S12KT256 and MC9S12KG256. Reserved space for MC9S12KG128(64)(32), MC9S12KL128(64) and MC9S12KC128(64).

\$0140 - \$017F

CAN0 (Motorola Scalable CAN - MSCAN)

Address	Name		Bit 7	Bit 6	Bit 5	Bit 4	Bit 3	Bit 2	Bit 1	Bit 0
\$0140	CAN0CTL0	Read:	RXFRM	RXACT	CSWAI	SYNCH	TIME	WUPE	SLPRQ	INITRQ
		Write:								
\$0141	CAN0CTL1	Read:	CANE	CLKSRC	LOOPB	LISTEN	0	WUPM	SLPAK	INITAK
		Write:								
\$0142	CAN0BTR0	Read:	SJW1	SJW0	BRP5	BRP4	BRP3	BRP2	BRP1	BRP0
		Write:								
\$0143	CAN0BTR1	Read:	SAMP	TSEG22	TSEG21	TSEG20	TSEG13	TSEG12	TSEG11	TSEG10
		Write:								
\$0144	CAN0RFLG	Read:	WUPIF	CSCIF	RSTAT1	RSTAT0	TSTAT1	TSTAT0	OVRIF	RXF
		Write:								

\$0140 - \$017F

CAN0 (Motorola Scalable CAN - MSCAN)

Address	Name		Bit 7	Bit 6	Bit 5	Bit 4	Bit 3	Bit 2	Bit 1	Bit 0
\$0145	CAN0RIER	Read:	WUPIE	CSCIE	RSTATE1	RSTATE0	TSTATE1	TSTATE0	OVRIE	RXFIE
		Write:								
\$0146	CAN0TFLG	Read:	0	0	0	0	0	TXE2	TXE1	TXE0
		Write:								
\$0147	CAN0TIER	Read:	0	0	0	0	0	TXEIE2	TXEIE1	TXEIE0
		Write:								
\$0148	CAN0TARQ	Read:	0	0	0	0	0	ABTRQ2	ABTRQ1	ABTRQ0
		Write:								
\$0149	CAN0TAAK	Read:	0	0	0	0	0	ABTAK2	ABTAK1	ABTAK0
		Write:								
\$014A	CAN0TBSEL	Read:	0	0	0	0	0	TX2	TX1	TX0
		Write:								
\$014B	CAN0IDAC	Read:	0	0	IDAM1	IDAM0	0	IDHIT2	IDHIT1	IDHIT0
		Write:								
\$014C	Reserved	Read:	0	0	0	0	0	0	0	0
		Write:								
\$014D	Reserved	Read:	0	0	0	0	0	0	0	0
		Write:								
\$014E	CAN0RXERR	Read:	RXERR7	RXERR6	RXERR5	RXERR4	RXERR3	RXERR2	RXERR1	RXERR0
		Write:								
\$014F	CAN0TXERR	Read:	TXERR7	TXERR6	TXERR5	TXERR4	TXERR3	TXERR2	TXERR1	TXERR0
		Write:								
\$0150 - \$0153	CAN0IDAR0 - CAN0IDAR3	Read:	AC7	AC6	AC5	AC4	AC3	AC2	AC1	AC0
		Write:								
\$0154 - \$0157	CAN0IDMR0 - CAN0IDMR3	Read:	AM7	AM6	AM5	AM4	AM3	AM2	AM1	AM0
		Write:								
\$0158 - \$015B	CAN0IDAR4 - CAN0IDAR7	Read:	AC7	AC6	AC5	AC4	AC3	AC2	AC1	AC0
		Write:								
\$015C - \$015F	CAN0IDMR4 - CAN0IDMR7	Read:	AM7	AM6	AM5	AM4	AM3	AM2	AM1	AM0
		Write:								
\$0160 - \$016F	CAN0RXFG	Read:	FOREGROUND RECEIVE BUFFER see (Table 1-3)							
		Write:								
\$0170 - \$017F	CAN0TXFG	Read:	FOREGROUND TRANSMIT BUFFER see (Table 1-3)							
		Write:								

Table 1-3 Detailed MSCAN Foreground Receive and Transmit Buffer Layout

Address	Name		Bit 7	Bit 6	Bit 5	Bit 4	Bit 3	Bit 2	Bit 1	Bit 0
\$xxx0	Extended ID	Read:	ID28	ID27	ID26	ID25	ID24	ID23	ID22	ID21
	Standard ID	Read:	ID10	ID9	ID8	ID7	ID6	ID5	ID4	ID3
\$xxx1	CANxRIDR0	Write:								
	Extended ID	Read:	ID20	ID19	ID18	SRR=1	IDE=1	ID17	ID16	ID15
\$xxx2	Standard ID	Read:	ID2	ID1	ID0	RTR	IDE=0			
	CANxRIDR1	Write:								
\$xxx3	Extended ID	Read:	ID14	ID13	ID12	ID11	ID10	ID9	ID8	ID7
	Standard ID	Read:								
\$xxx3	CANxRIDR2	Write:								
	Extended ID	Read:	ID6	ID5	ID4	ID3	ID2	ID1	ID0	RTR
\$xxx3	Standard ID	Read:								
	CANxRIDR3	Write:								

Table 1-3 Detailed MSCAN Foreground Receive and Transmit Buffer Layout

Address	Name		Bit 7	Bit 6	Bit 5	Bit 4	Bit 3	Bit 2	Bit 1	Bit 0
\$xxx4-\$xxxB	CANxRDSR0 - CANxRDSR7	Read:	DB7	DB6	DB5	DB4	DB3	DB2	DB1	DB0
		Write:								
\$xxxC	CANRxDLR	Read:					DLC3	DLC2	DLC1	DLC0
		Write:								
\$xxxD	Reserved	Read:								
		Write:								
\$xxxE	CANxRTSRH	Read:	TSR15	TSR14	TSR13	TSR12	TSR11	TSR10	TSR9	TSR8
		Write:								
\$xxxF	CANxRTSRL	Read:	TSR7	TSR6	TSR5	TSR4	TSR3	TSR2	TSR1	TSR0
		Write:								
\$xx10	Extended ID CANxTIDR0 Standard ID	Read:	ID28	ID27	ID26	ID25	ID24	ID23	ID22	ID21
		Write:								
\$xx10	Extended ID CANxTIDR1 Standard ID	Read:	ID20	ID19	ID18	SRR=1	IDE=1	ID17	ID16	ID15
		Write:	ID2	ID1	ID0	RTR	IDE=0			
\$xx12	Extended ID CANxTIDR2 Standard ID	Read:	ID14	ID13	ID12	ID11	ID10	ID9	ID8	ID7
		Write:								
\$xx13	Extended ID CANxTIDR3 Standard ID	Read:	ID6	ID5	ID4	ID3	ID2	ID1	ID0	RTR
		Write:								
\$xx14-\$xx1B	CANxTDSR0 - CANxTDSR7	Read:	DB7	DB6	DB5	DB4	DB3	DB2	DB1	DB0
		Write:								
\$xx1C	CANxTDLR	Read:					DLC3	DLC2	DLC1	DLC0
		Write:								
\$xx1D	CONxTTBPR	Read:	PRI07	PRI06	PRI05	PRI04	PRI03	PRI02	PRI01	PRI00
		Write:								
\$xx1E	CANxTTSRH	Read:	TSR15	TSR14	TSR13	TSR12	TSR11	TSR10	TSR9	TSR8
		Write:								
\$xx1F	CANxTTSRL	Read:	TSR7	TSR6	TSR5	TSR4	TSR3	TSR2	TSR1	TSR0
		Write:								

\$0180 - \$01BF

CAN1 (Motorola Scalable CAN - MSCAN)¹

Address	Name		Bit 7	Bit 6	Bit 5	Bit 4	Bit 3	Bit 2	Bit 1	Bit 0
\$0180	CAN1CTL0	Read:	RXFRM	RXACT	CSWAI	SYNCH	TIME	WUPE	SLPRQ	INITRQ
		Write:								
\$0181	CAN1CTL1	Read:	CANE	CLKSRC	LOOPB	LISTEN	0	WUPM	SLPAK	INITAK
		Write:								
\$0182	CAN1BTR0	Read:	SJW1	SJW0	BRP5	BRP4	BRP3	BRP2	BRP1	BRP0
		Write:								
\$0183	CAN1BTR1	Read:	SAMP	TSEG22	TSEG21	TSEG20	TSEG13	TSEG12	TSEG11	TSEG10
		Write:								

\$0180 - \$01BF**CAN1 (Motorola Scalable CAN - MSCAN)¹**

Address	Name		Bit 7	Bit 6	Bit 5	Bit 4	Bit 3	Bit 2	Bit 1	Bit 0
\$0184	CAN1RFLG	Read:	WUPIF	CSCIF	RSTAT1	RSTAT0	TSTAT1	TSTAT0	OVRIF	RXF
		Write:								
\$0185	CAN1RIER	Read:	WUPIE	CSCIE	RSTATE1	RSTATE0	TSTATE1	TSTATE0	OVRIE	RXFIE
		Write:								
\$0186	CAN1TFLG	Read:	0	0	0	0	0	TXE2	TXE1	TXE0
		Write:								
\$0187	CAN1TIER	Read:	0	0	0	0	0	TXEIE2	TXEIE1	TXEIE0
		Write:								
\$0188	CAN1TARQ	Read:	0	0	0	0	0	ABTRQ2	ABTRQ1	ABTRQ0
		Write:								
\$0189	CAN1TAAK	Read:	0	0	0	0	0	ABTAK2	ABTAK1	ABTAK0
		Write:								
\$018A	CAN1TBSEL	Read:	0	0	0	0	0	TX2	TX1	TX0
		Write:								
\$018B	CAN1IDAC	Read:	0	0	IDAM1	IDAM0	0	IDHIT2	IDHIT1	IDHIT0
		Write:								
\$018C	Reserved	Read:	0	0	0	0	0	0	0	0
		Write:								
\$018D	Reserved	Read:	0	0	0	0	0	0	0	0
		Write:								
\$018E	CAN1RXERR	Read:	RXERR7	RXERR6	RXERR5	RXERR4	RXERR3	RXERR2	RXERR1	RXERR0
		Write:								
\$018F	CAN1TXERR	Read:	TXERR7	TXERR6	TXERR5	TXERR4	TXERR3	TXERR2	TXERR1	TXERR0
		Write:								
\$0190	CAN1IDAR0	Read:	AC7	AC6	AC5	AC4	AC3	AC2	AC1	AC0
		Write:								
\$0191	CAN1IDAR1	Read:	AC7	AC6	AC5	AC4	AC3	AC2	AC1	AC0
		Write:								
\$0192	CAN1IDAR2	Read:	AC7	AC6	AC5	AC4	AC3	AC2	AC1	AC0
		Write:								
\$0193	CAN1IDAR3	Read:	AC7	AC6	AC5	AC4	AC3	AC2	AC1	AC0
		Write:								
\$0194	CAN1IDMR0	Read:	AM7	AM6	AM5	AM4	AM3	AM2	AM1	AM0
		Write:								
\$0195	CAN1IDMR1	Read:	AM7	AM6	AM5	AM4	AM3	AM2	AM1	AM0
		Write:								
\$0196	CAN1IDMR2	Read:	AM7	AM6	AM5	AM4	AM3	AM2	AM1	AM0
		Write:								
\$0197	CAN1IDMR3	Read:	AM7	AM6	AM5	AM4	AM3	AM2	AM1	AM0
		Write:								
\$0198	CAN1IDAR4	Read:	AC7	AC6	AC5	AC4	AC3	AC2	AC1	AC0
		Write:								
\$0199	CAN1IDAR5	Read:	AC7	AC6	AC5	AC4	AC3	AC2	AC1	AC0
		Write:								
\$019A	CAN1IDAR6	Read:	AC7	AC6	AC5	AC4	AC3	AC2	AC1	AC0
		Write:								
\$019B	CAN1IDAR7	Read:	AC7	AC6	AC5	AC4	AC3	AC2	AC1	AC0
		Write:								
\$019C	CAN1IDMR4	Read:	AM7	AM6	AM5	AM4	AM3	AM2	AM1	AM0
		Write:								

\$0180 - \$01BF

CAN1 (Motorola Scalable CAN - MSCAN)¹

Address	Name		Bit 7	Bit 6	Bit 5	Bit 4	Bit 3	Bit 2	Bit 1	Bit 0
\$019D	CAN1IDMR5	Read: Write:	AM7	AM6	AM5	AM4	AM3	AM2	AM1	AM0
\$019E	CAN1IDMR6	Read: Write:	AM7	AM6	AM5	AM4	AM3	AM2	AM1	AM0
\$019F	CAN1IDMR7	Read: Write:	AM7	AM6	AM5	AM4	AM3	AM2	AM1	AM0
\$01A0 - \$01AF	CAN1RXFG	Read: Write:	FOREGROUND RECEIVE BUFFER see (Table 1-3)							
\$01B0 - \$01BF	CAN1TXFG	Read: Write:	FOREGROUND TRANSMIT BUFFER see (Table 1-3)							

NOTES:

- Registers only available on MC9S12KT256. Reserved space for MC9S12KG256(128)(64)(32), MC9S12KL128(64) and MC9S12KC128(64).

\$01C0 - \$023F

Reserved space

Address	Name		Bit 7	Bit 6	Bit 5	Bit 4	Bit 3	Bit 2	Bit 1	Bit 0
\$01C0 - \$023F	Reserved	Read: Write:	0	0	0	0	0	0	0	0

\$0240 - \$027F

PIM (Port Integration Module)

Address	Name		Bit 7	Bit 6	Bit 5	Bit 4	Bit 3	Bit 2	Bit 1	Bit 0
\$0240	PTT	Read: Write:	PTT7	PTT6	PTT5	PTT4	PTT3	PTT2	PTT1	PTT0
\$0241	PTIT	Read: Write:	PTIT7	PTIT6	PTIT5	PTIT4	PTIT3	PTIT2	PTIT1	PTIT0
\$0242	DDRT	Read: Write:	DDRT7	DDRT7	DDRT5	DDRT4	DDRT3	DDRT2	DDRT1	DDRT0
\$0243	RDRT	Read: Write:	RDRT7	RDRT6	RDRT5	RDRT4	RDRT3	RDRT2	RDRT1	RDRT0
\$0244	PERT	Read: Write:	PERT7	PERT6	PERT5	PERT4	PERT3	PERT2	PERT1	PERT0
\$0245	PPST	Read: Write:	PPST7	PPST6	PPST5	PPST4	PPST3	PPST2	PPST1	PPST0
\$0246	Reserved	Read: Write:	0	0	0	0	0	0	0	0
\$0247	Reserved	Read: Write:	0	0	0	0	0	0	0	0
\$0248	PTS	Read: Write:	PTS7	PTS6	PTS5	PTS4	PTS3	PTS2	PTS1	PTS0
\$0249	PTIS	Read: Write:	PTIS7	PTIS6	PTIS5	PTIS4	PTIS3	PTIS2	PTIS1	PTIS0
\$024A	DDRS	Read: Write:	DDRS7	DDRS7	DDRS5	DDRS4	DDRS3	DDRS2	DDRS1	DDRS0
\$024B	RDRS	Read: Write:	RDRS7	RDRS6	RDRS5	RDRS4	RDRS3	RDRS2	RDRS1	RDRS0

\$0240 - \$027F**PIM (Port Integration Module)**

Address	Name		Bit 7	Bit 6	Bit 5	Bit 4	Bit 3	Bit 2	Bit 1	Bit 0
\$024C	PERS	Read:	PERS7	PERS6	PERS5	PERS4	PERS3	PERS2	PERS1	PERS0
		Write:								
\$024D	PPSS	Read:	PPSS7	PPSS6	PPSS5	PPSS4	PPSS3	PPSS2	PPSS1	PPSS0
		Write:								
\$024E	WOMS	Read:	WOMS7	WOMS6	WOMS5	WOMS4	WOMS3	WOMS2	WOMS1	WOMS0
		Write:								
\$024F	Reserved	Read:	0	0	0	0	0	0	0	0
		Write:								
\$0250	PTM	Read:	PTM7	PTM6	PTM5	PTM4	PTM3	PTM2	PTM1	PTM0
		Write:								
\$0251	PTIM	Read:	PTIM7	PTIM6	PTIM5	PTIM4	PTIM3	PTIM2	PTIM1	PTIM0
		Write:								
\$0252	DDRM	Read:	DDRM7	DDRM7	DDRM5	DDRM4	DDRM3	DDRM2	DDRM1	DDRM0
		Write:								
\$0253	RDRM	Read:	RDRM7	RDRM6	RDRM5	RDRM4	RDRM3	RDRM2	RDRM1	RDRM0
		Write:								
\$0254	PERM	Read:	PERM7	PERM6	PERM5	PERM4	PERM3	PERM2	PERM1	PERM0
		Write:								
\$0255	PPSM	Read:	PPSM7	PPSM6	PPSM5	PPSM4	PPSM3	PPSM2	PPSM1	PPSM0
		Write:								
\$0256	WOMM	Read:	WOMM7	WOMM6	WOMM5	WOMM4	WOMM3	WOMM2	WOMM1	WOMM0
		Write:								
\$0257	MODRR	Read:	0	MODRR6	MODRR5	MODRR4	MODRR3	MODRR2	MODRR1	MODRR0
		Write:								
\$0258	PTP	Read:	PTP7	PTP6	PTP5	PTP4	PTP3	PTP2	PTP1	PTP0
		Write:								
\$0259	PTIP	Read:	PTIP7	PTIP6	PTIP5	PTIP4	PTIP3	PTIP2	PTIP1	PTIP0
		Write:								
\$025A	DDRP	Read:	DDRP7	DDRP7	DDRP5	DDRP4	DDRP3	DDRP2	DDRP1	DDRP0
		Write:								
\$025B	RDRP	Read:	RDRP7	RDRP6	RDRP5	RDRP4	RDRP3	RDRP2	RDRP1	RDRP0
		Write:								
\$025C	PERP	Read:	PERP7	PERP6	PERP5	PERP4	PERP3	PERP2	PERP1	PERP0
		Write:								
\$025D	PPSP	Read:	PPSP7	PPSP6	PPSP5	PPSP4	PPSP3	PPSP2	PPSP1	PPSS0
		Write:								
\$025E	PIEP	Read:	PIEP7	PIEP6	PIEP5	PIEP4	PIEP3	PIEP2	PIEP1	PIEP0
		Write:								
\$025F	PIFP	Read:	PIFP7	PIFP6	PIFP5	PIFP4	PIFP3	PIFP2	PIFP1	PIFP0
		Write:								
\$0260	PTH	Read:	PTH7	PTH6	PTH5	PTH4	PTH3	PTH2	PTH1	PTH0
		Write:								
\$0261	PTIH	Read:	PTIH7	PTIH6	PTIH5	PTIH4	PTIH3	PTIH2	PTIH1	PTIH0
		Write:								
\$0262	DDRH	Read:	DDRH7	DDRH7	DDRH5	DDRH4	DDRH3	DDRH2	DDRH1	DDRH0
		Write:								
\$0263	RDRH	Read:	RDRH7	RDRH6	RDRH5	RDRH4	RDRH3	RDRH2	RDRH1	RDRH0
		Write:								
\$0264	PERH	Read:	PERH7	PERH6	PERH5	PERH4	PERH3	PERH2	PERH1	PERH0
		Write:								

\$0240 - \$027F

PIM (Port Integration Module)

Address	Name		Bit 7	Bit 6	Bit 5	Bit 4	Bit 3	Bit 2	Bit 1	Bit 0
\$0265	PPSH	Read:	PPSH7	PPSH6	PPSH5	PPSH4	PPSH3	PPSH2	PPSH1	PPSH0
		Write:								
\$0266	PIEH	Read:	PIEH7	PIEH6	PIEH5	PIEH4	PIEH3	PIEH2	PIEH1	PIEH0
		Write:								
\$0267	PIFH	Read:	PIFH7	PIFH6	PIFH5	PIFH4	PIFH3	PIFH2	PIFH1	PIFH0
		Write:								
\$0268	PTJ	Read:	PTJ7	PTJ6	0	0	0	0	PTJ1	PTJ0
		Write:								
\$0269	PTIJ	Read:	PTIJ7	PTIJ6	0	0	0	0	PTIJ1	PTIJ0
		Write:								
\$026A	DDRJ	Read:	DDRJ7	DDRJ6	0	0	0	0	DDRJ1	DDRJ0
		Write:								
\$026B	RDRJ	Read:	RDRJ7	RDRJ6	0	0	0	0	RDRJ1	RDRJ0
		Write:								
\$026C	PERJ	Read:	PERJ7	PERJ6	0	0	0	0	PERJ1	PERJ0
		Write:								
\$026D	PPSJ	Read:	PPSJ7	PPSJ6	0	0	0	0	PPSJ1	PPSJ0
		Write:								
\$026E	PIEJ	Read:	PIEJ7	PIEJ6	0	0	0	0	PIEJ1	PIEJ0
		Write:								
\$026F	PIFJ	Read:	PIFJ7	PIFJ6	0	0	0	0	PIFJ1	PIFJ0
		Write:								
\$0270 - \$027F	Reserved	Read:								

\$0280 - \$02BF

CAN4 (Motorola Scalable CAN - MSCAN)

Address	Name		Bit 7	Bit 6	Bit 5	Bit 4	Bit 3	Bit 2	Bit 1	Bit 0
\$0280	CAN4CTL0	Read:	RXFRM	RXACT	CSWAI	SYNCH	TIME	WUPE	SLPRQ	INITRQ
		Write:								
\$0281	CAN4CTL1	Read:	CANE	CLKSRC	LOOPB	LISTEN	0	WUPM	SLPAK	INITAK
		Write:								
\$0282	CAN4BTR0	Read:	SJW1	SJW0	BRP5	BRP4	BRP3	BRP2	BRP1	BRP0
		Write:								
\$0283	CAN4BTR1	Read:	SAMP	TSEG22	TSEG21	TSEG20	TSEG13	TSEG12	TSEG11	TSEG10
		Write:								
\$0284	CAN4RFLG	Read:	WUPIF	CSCIF	RSTAT1	RSTAT0	TSTAT1	TSTAT0	OVRIF	RXF
		Write:								
\$0285	CAN4RIER	Read:	WUPIE	CSCIE	RSTATE1	RSTATE0	TSTATE1	TSTATE0	OVRIE	RXFIE
		Write:								
\$0286	CAN4TFLG	Read:	0	0	0	0	0	TXE2	TXE1	TXE0
		Write:								
\$0287	CAN4TIER	Read:	0	0	0	0	0	TXEIE2	TXEIE1	TXEIE0
		Write:								
\$0288	CAN4TARQ	Read:	0	0	0	0	0	ABTRQ2	ABTRQ1	ABTRQ0
		Write:								
\$0289	CAN4TAAK	Read:	0	0	0	0	0	ABTAK2	ABTAK1	ABTAK0
		Write:								
\$028A	CAN4TBSEL	Read:	0	0	0	0	0	TX2	TX1	TX0
		Write:								

\$0280 - \$02BF**CAN4 (Motorola Scalable CAN - MSCAN)**

Address	Name		Bit 7	Bit 6	Bit 5	Bit 4	Bit 3	Bit 2	Bit 1	Bit 0
\$028B	CAN4IDAC	Read:	0	0	IDAM1	IDAM0	0	IDHIT2	IDHIT1	IDHIT0
		Write:								
\$028C	Reserved	Read:	0	0	0	0	0	0	0	0
		Write:								
\$028D	Reserved	Read:	0	0	0	0	0	0	0	0
		Write:								
\$028E	CAN4RXERR	Read:	RXERR7	RXERR6	RXERR5	RXERR4	RXERR3	RXERR2	RXERR1	RXERR0
		Write:								
\$028F	CAN4TXERR	Read:	TXERR7	TXERR6	TXERR5	TXERR4	TXERR3	TXERR2	TXERR1	TXERR0
		Write:								
\$0290	CAN4IDAR0	Read:	AC7	AC6	AC5	AC4	AC3	AC2	AC1	AC0
		Write:								
\$0291	CAN4IDAR1	Read:	AC7	AC6	AC5	AC4	AC3	AC2	AC1	AC0
		Write:								
\$0292	CAN4IDAR2	Read:	AC7	AC6	AC5	AC4	AC3	AC2	AC1	AC0
		Write:								
\$0293	CAN4IDAR3	Read:	AC7	AC6	AC5	AC4	AC3	AC2	AC1	AC0
		Write:								
\$0294	CAN4IDMR0	Read:	AM7	AM6	AM5	AM4	AM3	AM2	AM1	AM0
		Write:								
\$0295	CAN4IDMR1	Read:	AM7	AM6	AM5	AM4	AM3	AM2	AM1	AM0
		Write:								
\$0296	CAN4IDMR2	Read:	AM7	AM6	AM5	AM4	AM3	AM2	AM1	AM0
		Write:								
\$0297	CAN4IDMR3	Read:	AM7	AM6	AM5	AM4	AM3	AM2	AM1	AM0
		Write:								
\$0298	CAN4IDAR4	Read:	AC7	AC6	AC5	AC4	AC3	AC2	AC1	AC0
		Write:								
\$0299	CAN4IDAR5	Read:	AC7	AC6	AC5	AC4	AC3	AC2	AC1	AC0
		Write:								
\$029A	CAN4IDAR6	Read:	AC7	AC6	AC5	AC4	AC3	AC2	AC1	AC0
		Write:								
\$029B	CAN4IDAR7	Read:	AC7	AC6	AC5	AC4	AC3	AC2	AC1	AC0
		Write:								
\$029C	CAN4IDMR4	Read:	AM7	AM6	AM5	AM4	AM3	AM2	AM1	AM0
		Write:								
\$029D	CAN4IDMR5	Read:	AM7	AM6	AM5	AM4	AM3	AM2	AM1	AM0
		Write:								
\$029E	CAN4IDMR6	Read:	AM7	AM6	AM5	AM4	AM3	AM2	AM1	AM0
		Write:								
\$029F	CAN4IDMR7	Read:	AM7	AM6	AM5	AM4	AM3	AM2	AM1	AM0
		Write:								
\$02A0 - \$02AF	CAN4RXFG	Read:	FOREGROUND RECEIVE BUFFER see (Table 1-3)							
		Write:								
\$02B0 - \$02BF	CAN4TXFG	Read:	FOREGROUND TRANSMIT BUFFER see (Table 1-3)							
		Write:								

\$02C0 - \$02E7

PWM (Pulse Width Modulator 8 Bit 8 Channel)

Address	Name		Bit 7	Bit 6	Bit 5	Bit 4	Bit 3	Bit 2	Bit 1	Bit 0
\$02C0	PWME	Read:	PWME7	PWME6	PWME5	PWME4	PWME3	PWME2	PWME1	PWME0
		Write:								
\$02C1	PWMPOL	Read:	PPOL7	PPOL6	PPOL5	PPOL4	PPOL3	PPOL2	PPOL1	PPOL0
		Write:								
\$02C2	PWMCLK	Read:	PCLK7	PCLK6	PCLK5	PCLK4	PCLK3	PCLK2	PCLK1	PCLK0
		Write:								
\$02C3	PWMPRCLK	Read:	0	PCKB2	PCKB1	PCKB0	0	PCKA2	PCKA1	PCKA0
		Write:								
\$02C4	PWMC AE	Read:	CAE7	CAE6	CAE5	CAE4	CAE3	CAE2	CAE1	CAE0
		Write:								
\$02C5	PWMCTL	Read:	CON67	CON45	CON23	CON01	PSWAI	PFRZ	0	0
		Write:								
\$02C6	PWMTST Test Only	Read:	0	0	0	0	0	0	0	0
		Write:								
\$02C7	PWMPRSC	Read:	0	0	0	0	0	0	0	0
		Write:								
\$02C8	PWMSCLA	Read:	Bit 7	6	5	4	3	2	1	Bit 0
		Write:								
\$02C9	PWMSCLB	Read:	Bit 7	6	5	4	3	2	1	Bit 0
		Write:								
\$02CA	PWMSCNTA	Read:	0	0	0	0	0	0	0	0
		Write:								
\$02CB	PWMSCNTB	Read:	0	0	0	0	0	0	0	0
		Write:								
\$02CC	PWMCNT0	Read:	Bit 7	6	5	4	3	2	1	Bit 0
		Write:	0	0	0	0	0	0	0	0
\$02CD	PWMCNT1	Read:	Bit 7	6	5	4	3	2	1	Bit 0
		Write:	0	0	0	0	0	0	0	0
\$02CE	PWMCNT2	Read:	Bit 7	6	5	4	3	2	1	Bit 0
		Write:	0	0	0	0	0	0	0	0
\$02CF	PWMCNT3	Read:	Bit 7	6	5	4	3	2	1	Bit 0
		Write:	0	0	0	0	0	0	0	0
\$02D0	PWMCNT4	Read:	Bit 7	6	5	4	3	2	1	Bit 0
		Write:	0	0	0	0	0	0	0	0
\$02D1	PWMCNT5	Read:	Bit 7	6	5	4	3	2	1	Bit 0
		Write:	0	0	0	0	0	0	0	0
\$02D2	PWMCNT6	Read:	Bit 7	6	5	4	3	2	1	Bit 0
		Write:	0	0	0	0	0	0	0	0
\$02D3	PWMCNT7	Read:	Bit 7	6	5	4	3	2	1	Bit 0
		Write:	0	0	0	0	0	0	0	0
\$02D4	PWMPER0	Read:	Bit 7	6	5	4	3	2	1	Bit 0
		Write:								
\$02D5	PWMPER1	Read:	Bit 7	6	5	4	3	2	1	Bit 0
		Write:								
\$02D6	PWMPER2	Read:	Bit 7	6	5	4	3	2	1	Bit 0
		Write:								
\$02D7	PWMPER3	Read:	Bit 7	6	5	4	3	2	1	Bit 0
		Write:								
\$02D8	PWMPER4	Read:	Bit 7	6	5	4	3	2	1	Bit 0
		Write:								

\$02C0 - \$02E7

PWM (Pulse Width Modulator 8 Bit 8 Channel)

Address	Name		Bit 7	Bit 6	Bit 5	Bit 4	Bit 3	Bit 2	Bit 1	Bit 0
\$02D9	PWMPER5	Read:	Bit 7	6	5	4	3	2	1	Bit 0
		Write:								
\$02DA	PWMPER6	Read:	Bit 7	6	5	4	3	2	1	Bit 0
		Write:								
\$02DB	PWMPER7	Read:	Bit 7	6	5	4	3	2	1	Bit 0
		Write:								
\$02DC	PWMDTY0	Read:	Bit 7	6	5	4	3	2	1	Bit 0
		Write:								
\$02DD	PWMDTY1	Read:	Bit 7	6	5	4	3	2	1	Bit 0
		Write:								
\$02DE	PWMDTY2	Read:	Bit 7	6	5	4	3	2	1	Bit 0
		Write:								
\$02DF	PWMDTY3	Read:	Bit 7	6	5	4	3	2	1	Bit 0
		Write:								
\$02E0	PWMDTY4	Read:	Bit 7	6	5	4	3	2	1	Bit 0
		Write:								
\$02E1	PWMDTY5	Read:	Bit 7	6	5	4	3	2	1	Bit 0
		Write:								
\$02E2	PWMDTY6	Read:	Bit 7	6	5	4	3	2	1	Bit 0
		Write:								
\$02E3	PWMDTY7	Read:	Bit 7	6	5	4	3	2	1	Bit 0
		Write:								
\$02E4	PWMSDN	Read:	PWMIF	PWMIE	PWMRS TRT	PWMLVL	0	PWM7IN	PWM7IN L	PWM7E NA
		Write:								
\$02E5	Reserved	Read:	0	0	0	0	0	0	0	0
		Write:								
\$02E6	Reserved	Read:	0	0	0	0	0	0	0	0
		Write:								
\$02E7	Reserved	Read:	0	0	0	0	0	0	0	0
		Write:								

\$02E8 - \$03FF

Reserved space

Address	Name		Bit 7	Bit 6	Bit 5	Bit 4	Bit 3	Bit 2	Bit 1	Bit 0
\$02E8 - \$03FF	Reserved	Read:	0	0	0	0	0	0	0	0
		Write:								

1.8 Part ID Assignments

The part ID is located in two 8-bit registers PARTIDH and PARTIDL (addresses \$001A and \$001B after reset. The read-only value is a unique part ID for each revision of the chip. **Table 1-4 Assigned Part ID Numbers** shows the assigned part ID number.

Table 1-4 Assigned Part ID Numbers

Device	Mask Set Number	Part ID ¹
MC9S12KT256	0L33V	\$7000
MC9S12KG128	0L74N	\$7100

NOTES:

- The coding is as follows:
 Bit 15-12: Major family identifier
 Bit 11-8: Minor family identifier
 Bit 7-4: Major mask set revision number including FAB transfers
 Bit 3-0: Minor - non full - mask set revision

The device memory sizes are located in two 8-bit registers MEMSIZ0 and MEMSIZ1 (addresses \$001C and \$001D after reset). **Table 1-5** shows the read-only values of these registers. Refer to HCS12 Module Mapping and Control (MMC) Block Guide for further details.

Table 1-5 Memory size registers

Device	Register name	Value
MC9S12KT256	MEMSIZ0	\$25
MC9S12KT256	MEMSIZ1	\$81
MC9S12KG128	MEMSIZ0	\$13
MC9S12KG128	MEMSIZ1	\$80

Section 2 Signal Description

2.1 Device Pinout

The MC9S12K-Family and its derivatives are available in a 112-pin low profile quad flat pack (LQFP), a 100-pin low profile quad flat pack (LQFP), and a 80-pin quad flat pack (QFP). Most pins perform two or more functions, as described in the Signal Descriptions. **Figure 2-1**, **Figure 2-2** and **Figure 2-3** show the pin assignments for different packages.

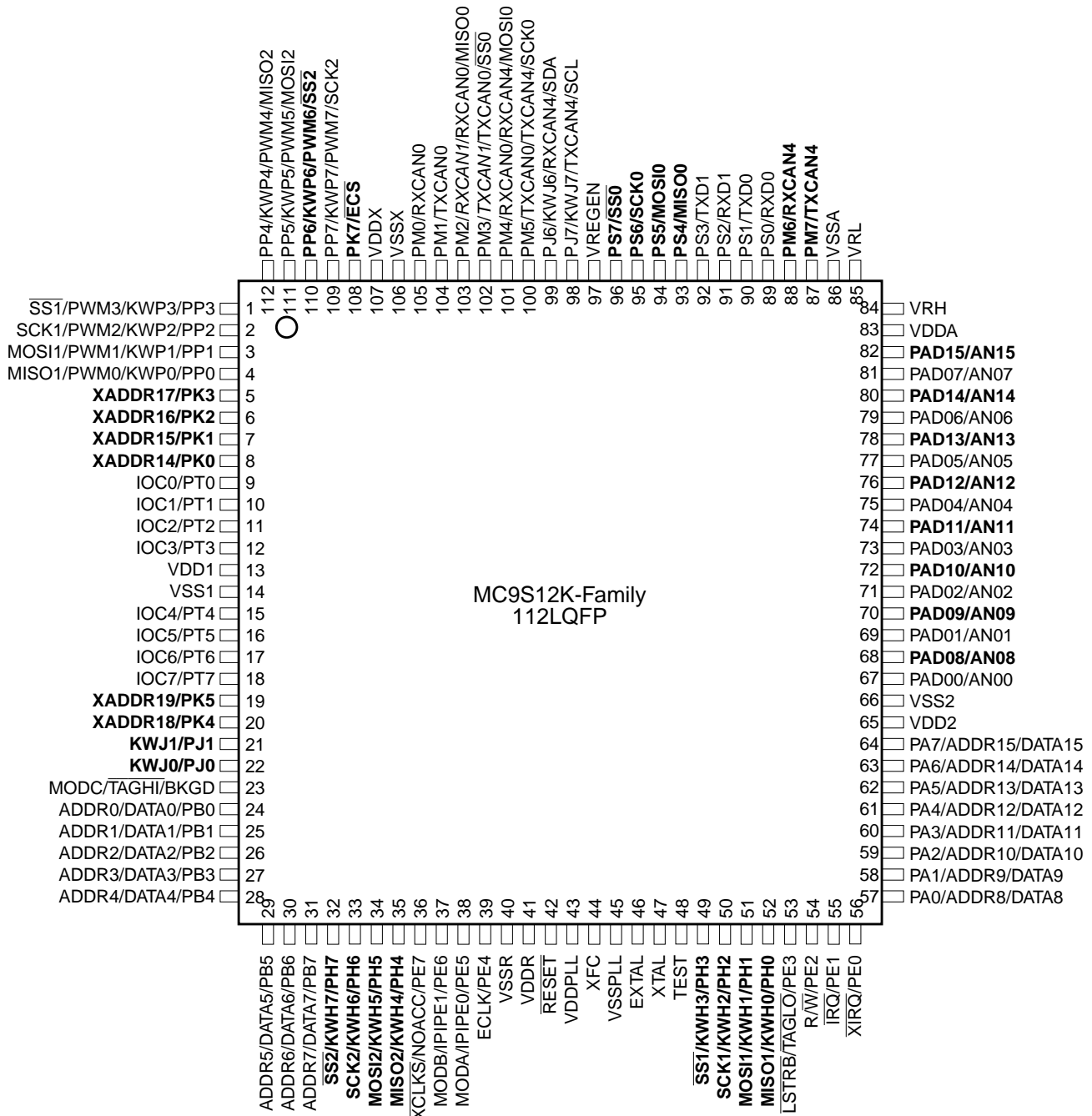

Signals shown in **Bold** are not available on the 80 Pin Package
 Signals shown in *Italic* are only available in MC9S12KT256

Figure 2-1 Pin assignments for 112 LQFP

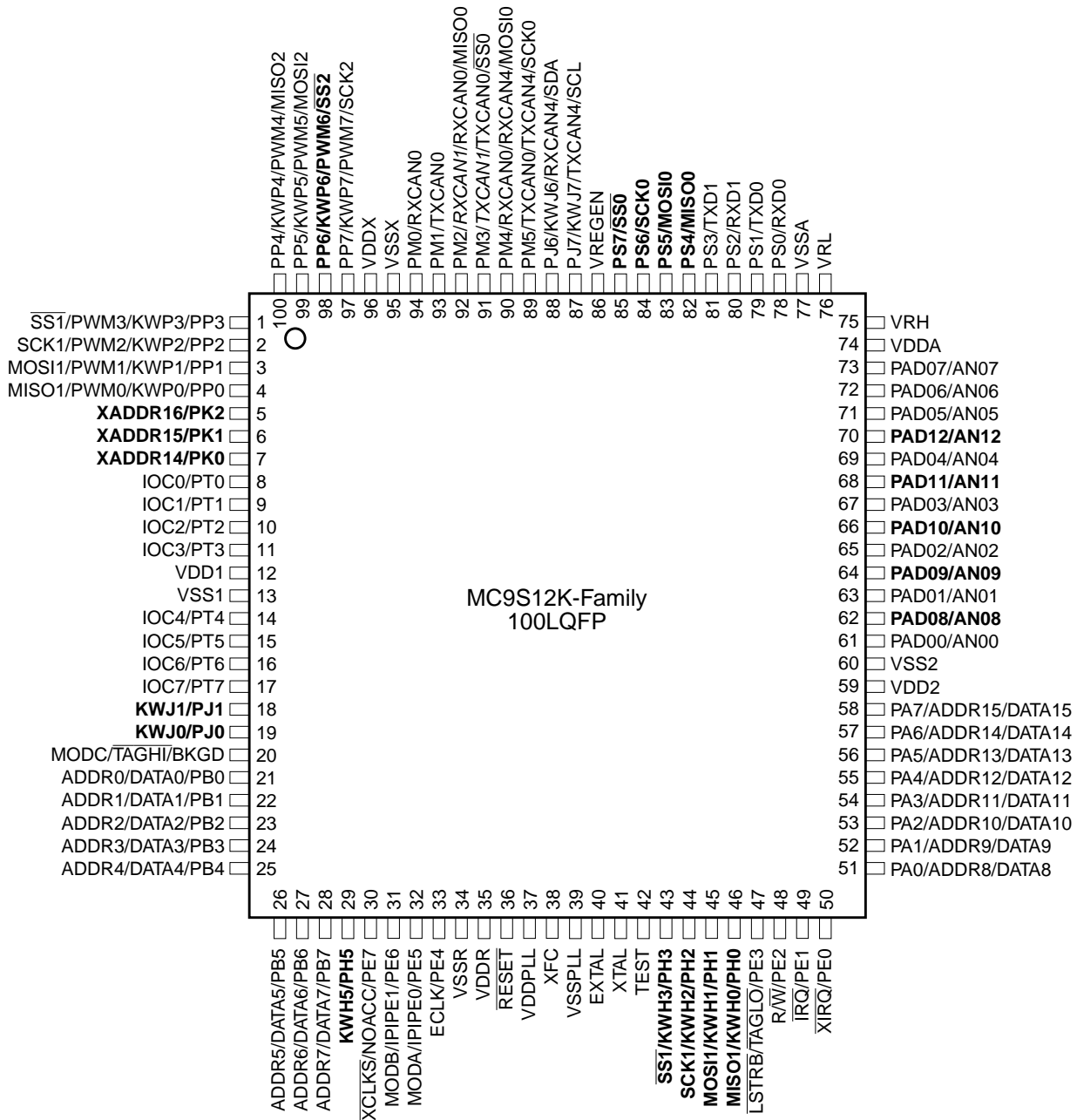

Signals shown in **Bold** are not available on the 80 Pin Package
 Signals shown in *Italics* are only available in MC9S12KT256

Figure 2-2 Pin assignments for 100 LQFP

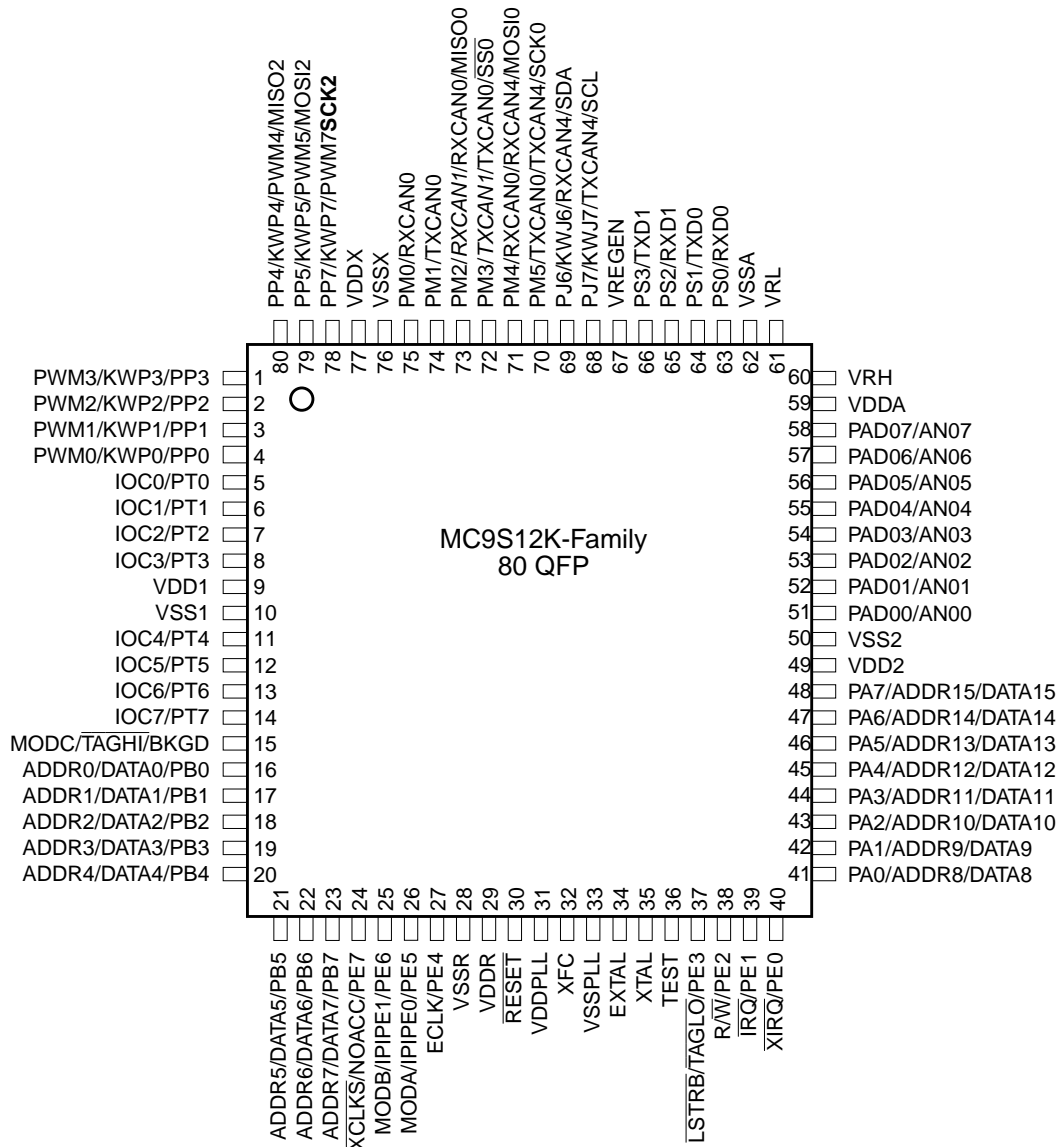

Signals shown in *Italic* are only available in MC9S12KT256

Figure 2-3 Pin assignments for 80 QFP

2.2 Signal Properties Summary

(Table 2-1) summarizes the pin functionality. Signals shown in **bold** are not available in the 80 pin package. (Table 2-2) summarizes the power and ground pins.

Table 2-1 Signal Properties

Pin Name Function 1	Pin Name Function 2	Pin Name Function 3	Pin Name Function 4	Powered by	Internal Pull Resistor		Description
					CTRL	Reset State	
EXTAL	—	—	—	VDDPLL	NA	NA	Oscillator Pins
XTAL	—	—	—	VDDPLL	NA	NA	
$\overline{\text{RESET}}$	—	—	—	VDDR	None	None	External Reset
TEST	—	—	—	NA	NA	NA	Test Input
VREGEN	—	—	—	VDDX	NA	NA	Voltage Regulator Enable Input
XFC	—	—	—	VDDPLL	NA	NA	PLL Loop Filter
BKGD	$\overline{\text{TAGHI}}$	MODC	—	VDDR	Always Up	Up	Background Debug, Tag High, Mode Input
PAD[15:8]	AN[15:8]	AN1[7:0]¹	—	VDDA	None	None	Port AD Input, Analog Inputs of ATD in MC9S12KG128(64)(32), MC9S12KL128(64) and MC9S12KC128(64); Analog Inputs of ATD1 in MC9S12KT256 and MC9S12KG256
PAD[7:0]	AN[7:0]	AN0[7:0] ¹	—	VDDA	None	None	Port AD Input, Analog Inputs of ATD in MC9S12KG128(64)(32), MC9S12KL128(64) and MC9S12KC128(64); Analog Inputs of ATD0 in MC9S12KT256 and MC9S12KG256
PA[7:0]	ADDR[15:8]/ DATA[15:8]	—	—	VDDR	PUCR	Disabled	Port A I/O, Multiplexed Address/Data
PB[7:0]	ADDR[7:0]/ DATA[7:0]	—	—	VDDR	PUCR	Disabled	Port B I/O, Multiplexed Address/Data
PE7	NOACC	$\overline{\text{XCLKS}}$	—	VDDR	PUCR	Up	Port E I/O, Access, Clock Select
PE6	IPIPE1	MODB	—	VDDR	While $\overline{\text{RESET}}$ pin is low: Down		Port E I/O, Pipe Status, Mode Input
PE5	IPIPE0	MODA	—	VDDR	While $\overline{\text{RESET}}$ pin is low: Down		Port E I/O, Pipe Status, Mode Input
PE4	ECLK	—	—	VDDR	PUCR	Up	Port E I/O, Bus Clock Output
PE3	$\overline{\text{LSTRB}}$	$\overline{\text{TAGLO}}$	—	VDDR	PUCR	Up	Port E I/O, Byte Strobe, Tag Low
PE2	R/ $\overline{\text{W}}$	—	—	VDDR	PUCR	Up	Port E I/O, R/ $\overline{\text{W}}$ in expanded modes
PE1	$\overline{\text{IRQ}}$	—	—	VDDR	Always Up		Port E Input, Maskable Interrupt
PE0	$\overline{\text{XIRQ}}$	—	—	VDDR			Port E Input, Non Maskable Interrupt
PH7	KWH7	$\overline{\text{SS2}}$	—	VDDR	PERH/ PPSH	Disabled	Port H I/O, Interrupt, $\overline{\text{SS}}$ of SPI2

Pin Name Function 1	Pin Name Function 2	Pin Name Function 3	Pin Name Function 4	Powered by	Internal Pull Resistor		Description
					CTRL	Reset State	
PH6	KWH6	SCK2	—	VDDR	PERH/PPSH	Disabled	Port H I/O, Interrupt, SCK of SPI2
PH5	KWH5	MOSI2	—	VDDR	PERH/PPSH	Disabled	Port H I/O, Interrupt, MOSI of SPI2
PH4	KWH4	MISO2	—	VDDR	PERH/PPSH	Disabled	Port H I/O, Interrupt, MISO of SPI2
PH3	KWH3	$\overline{SS}1$	—	VDDR	PERH/PPSH	Disabled	Port H I/O, Interrupt, \overline{SS} of SPI1
PH2	KWH2	SCK1	—	VDDR	PERH/PPSH	Disabled	Port H I/O, Interrupt, SCK of SPI1
PH1	KWH1	MOSI1	—	VDDR	PERH/PPSH	Disabled	Port H I/O, Interrupt, MOSI of SPI1
PH0	KWH0	MISO1	—	VDDR	PERH/PPSH	Disabled	Port H I/O, Interrupt, MISO of SPI1
PJ7	KWJ7	TXCAN4	SCL	VDDX	PERJ/PPSJ	Up	Port J I/O, Interrupt, TX of CAN4, SCL of IIC
PJ6	KWJ6	RXCAN4	SDA	VDDX	PERJ/PPSJ	Up	Port J I/O, Interrupt, RX of CAN4, SDA of IIC
PJ[1:0]	KWJ[1:0]	—	—	VDDX	PERJ/PPSJ	Up	Port J I/O, Interrupts
PK7	\overline{ECS}	ROMCTL	—	VDDX	PUCR	Up	Port K I/O, Emulation Chip Select, ROM On Enable
PK[5:0]	XADDR[19:14]	—	—	VDDX	PUCR	Up	Port K I/O, Extended Addresses
PM7	TXCAN4	—	—	VDDX	PERM/PPSM	Disabled	Port M I/O, CAN4 TX
PM6	RXCAN4	—	—	VDDX	PERM/PPSM	Disabled	Port M I/O, CAN4 RX
PM5	TXCAN0	TXCAN4	SCK0	VDDX	PERM/PPSM	Disabled	Port M I/O, CAN0 TX, CAN4 TX, SPI0 SCK
PM4	RXCAN0	RXCAN4	MOSI0	VDDX	PERM/PPSM	Disabled	Port M I/O, CAN0 RX, CAN4 RX, SPI0 MOSI
PM3	TXCAN1 ¹	TXCAN0	$\overline{SS}0$	VDDX	PERM/PPSM	Disabled	Port M I/O, CAN1 TX, CAN0 TX, SPI0 \overline{SS}
PM2	RXCAN1 ¹	RXCAN0	MISO0	VDDX	PERM/PPSM	Disabled	Port M I/O, CAN1 RX, CAN0 RX, SPI0 MISO
PM1	TXCAN0	—	—	VDDX	PERM/PPSM	Disabled	Port M I/O, CAN0 TX
PM0	RXCAN0	—	—	VDDX	PERM/PPSM	Disabled	Port M I/O, CAN0 RX
PP7	KWP7	PWM7	SCK2	VDDX	PERP/PPSP	Disabled	Port P I/O, Interrupt, PWM Channel 7, SCK of SPI2
PP6	KWP6	PWM6	$\overline{SS}2$	VDDX	PERP/PPSP	Disabled	Port P I/O, Interrupt, PWM Channel 6, SPI2 \overline{SS}
PP5	KWP5	PWM5	MOSI2	VDDX	PERP/PPSP	Disabled	Port P I/O, Interrupt, PWM Channel 5, SPI2 MOSI
PP4	KWP4	PWM4	MISO2	VDDX	PERP/PPSP	Disabled	Port P I/O, Interrupt, PWM Channel 4, SPI2 MISO

Pin Name Function 1	Pin Name Function 2	Pin Name Function 3	Pin Name Function 4	Powered by	Internal Pull Resistor		Description
					CTRL	Reset State	
PP3	KWP3	PWM3	SS1	VDDX	PERP/PPSP	Disabled	Port P I/O, Interrupt, PWM Channel 3, SPI1 SS
PP2	KWP2	PWM2	SCK1	VDDX	PERP/PPSP	Disabled	Port P I/O, Interrupt, PWM Channel 2, SPI1 SCK
PP1	KWP1	PWM1	MOSI1	VDDX	PERP/PPSP	Disabled	Port P I/O, Interrupt, PWM Channel 1, SPI1 MOSI
PP0	KWP0	PWM0	MISO1	VDDX	PERP/PPSP	Disabled	Port P I/O, Interrupt, PWM Channel 0, SPI1 MISO
PS7	SS0	—	—	VDDX	PERS/PPSS	Up	Port S I/O, SPI0 SS
PS6	SCK0	—	—	VDDX	PERS/PPSS	Up	Port S I/O, SPI0 SCK
PS5	MOSI0	—	—	VDDX	PERS/PPSS	Up	Port S I/O, SPI0 MOSI
PS4	MISO0	—	—	VDDX	PERS/PPSS	Up	Port S I/O, SPI0 MISO
PS3	TXD1	—	—	VDDX	PERS/PPSS	Up	Port S I/O, SCI1TXD
PS2	RXD1	—	—	VDDX	PERS/PPSS	Up	Port S I/O, SCI1RXD
PS1	TXD0	—	—	VDDX	PERS/PPSS	Up	Port S I/O, SCI0 TXD
PS0	RXD0	—	—	VDDX	PERS/PPSS	Up	Port S I/O, SCI0 RXD
PT[7:0]	IOC[7:0]	—	—	VDDX	Up or Down	Disabled	Port T I/O, Timer channels

NOTES:

1. Only available on MC9S12KT256.

Table 2-2 Power and Ground

Mnemonic	Nominal Voltage	Description
VDD1 VDD2	2.5 V	Internal power and ground generated by internal regulator. These also allow an external source to supply the core VDD/VSS voltages and bypass the internal voltage regulator.
VSS1 VSS2	0 V	
VDDR VSSR	3.3/5.0 V 0 V	External power and ground, supply to pin drivers and internal voltage regulator.
VDDX VSSX	3.3/5.0 V 0 V	External power and ground, supply to pin drivers.
VDDA VSSA	3.3/5.0 V 0 V	Operating voltage and ground for the analog-to-digital converter and the reference for the internal voltage regulator, allows the supply voltage to the A/D to be bypassed independently.
VRH	3.3/5.0 V	Reference voltage high for the ATD converter.
VRL	0 V	Reference voltage low for the ATD converter.

Mnemonic	Nominal Voltage	Description
VDDPLL	2.5 V	Provides operating voltage and ground for the Phased-Locked Loop.
VSSPLL	0 V	This allows the supply voltage to the PLL to be bypassed independently. Internal power and ground generated by internal regulator.

NOTE: *All VSS pins must be connected together in the application. Because fast signal transitions place high, short-duration current demands on the power supply, use bypass capacitors with high-frequency characteristics and place them as close to the MCU as possible. Bypass requirements depend on MCU pin load.*

2.3 Detailed Signal Descriptions

2.3.1 EXTAL, XTAL — Oscillator Pins

EXTAL and XTAL are the crystal driver and external clock pins. On reset all the device clocks are derived from the EXTAL input frequency. XTAL is the crystal output.

2.3.2 $\overline{\text{RESET}}$ — External Reset Pin

An active low bidirectional control signal, it acts as an input to initialize the MCU to a known start-up state, and an output when an internal MCU function causes a reset.

2.3.3 TEST — Test Pin

This input only pin is reserved for test.

NOTE: *The TEST pin must be tied to VSS in all applications.*

2.3.4 VREGEN — Voltage Regulator Enable Pin

This input only pin enables or disables the on-chip voltage regulator.

2.3.5 XFC — PLL Loop Filter Pin

PLL loop filter. Please ask your Motorola representative for the interactive application note to compute PLL loop filter elements. Any current leakage on this pin must be avoided.

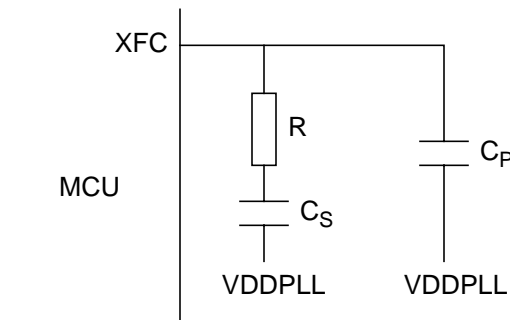

Figure 2-4 PLL Loop Filter Connections

2.3.6 BKGD / $\overline{\text{TAGHI}}$ / MODC — Background Debug, Tag High, and Mode Pin

The BKGD/ $\overline{\text{TAGHI}}$ /MODC pin is used as a pseudo-open-drain pin for the background debug communication. In MCU expanded modes of operation when instruction tagging is on, an input low on this pin during the falling edge of E-clock tags the high half of the instruction word being read into the instruction queue. It is used as a MCU operating mode select pin during reset. The state of this pin is latched to the MODC bit at the rising edge of $\overline{\text{RESET}}$.

2.3.7 PAD[15:8] / AN[15:8] — Port AD Input Pins [15:8]

PAD15 - PAD8 are general purpose input pins and analog inputs of the single analog to digital converter with 16 channels on MC9S12KG128(64)(32), MC9S12KL128(64) and MC9S12KC128(64). PAD15 - PAD8 are general purpose input pins and analog inputs of the analog to digital converter with 8 channels (ATD1) on MC9S12KT256 and MC9S12KG256.

2.3.8 PAD[7:0] / AN[7:0] — Port AD Input Pins [7:0]

PAD7 - PAD0 are general purpose input pins and analog inputs of the single analog to digital converter with 16 channels on MC9S12KG128(64)(32), MC9S12KL128(64) and MC9S12KC128(64). PAD7 - PAD0 are general purpose input pins and analog inputs of the analog to digital converter with 8 channels (ATD0) on MC9S12KT256 and MC9S12KG256.

2.3.9 PA[7:0] / ADDR[15:8] / DATA[15:8] — Port A I/O Pins

PA7-PA0 are general purpose input or output pins. In MCU expanded modes of operation, these pins are used for the multiplexed external address and data bus.

2.3.10 PB[7:0] / ADDR[7:0] / DATA[7:0] — Port B I/O Pins

PB7-PB0 are general purpose input or output pins. In MCU expanded modes of operation, these pins are used for the multiplexed external address and data bus.

2.3.11 PE7 / NOACC / \overline{XCLKS} — Port E I/O Pin 7

PE7 is a general purpose input or output pin. During MCU expanded modes of operation, the NOACC signal, when enabled, is used to indicate that the current bus cycle is an unused or “free” cycle. This signal will assert when the CPU is not using the bus.

The \overline{XCLKS} is an input signal which controls whether a crystal in combination with the internal Loop Controlled Pierce (low power) oscillator is used or whether Full Swing Pierce oscillator/external clock circuitry is used. The state of this pin is latched at the rising edge of \overline{RESET} . If the input is a logic low the EXTAL pin is configured for an external clock drive or Full Swing Pierce Oscillator. If input is a logic high a Loop Controlled Pierce oscillator circuit is configured on EXTAL and XTAL. Since this pin is an input with a pull-up device during reset, if the pin is left floating, the default configuration is a Loop Controlled Pierce oscillator circuit on EXTAL and XTAL.

Table 2-3 Clock selection based on PE7 during reset

PE7	Description
1	Loop Controlled Pierce Oscillator selected
0	Full Swing Pierce Oscillator or external clock selected

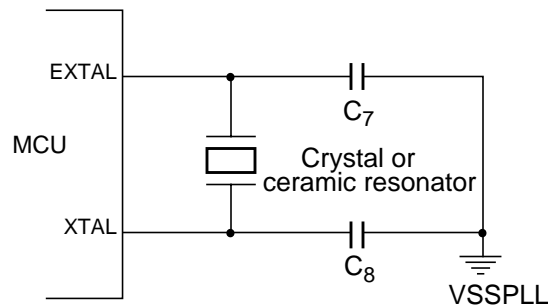
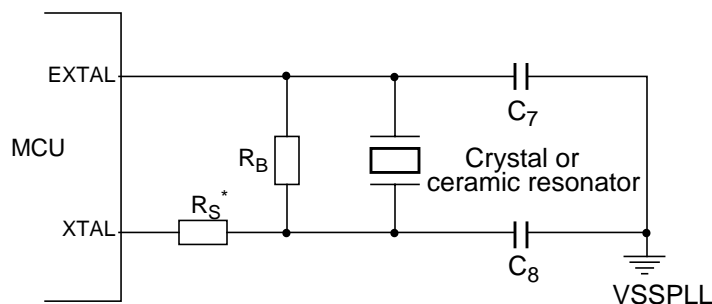

Figure 2-5 Loop Controlled Pierce Oscillator Connections (PE7=1)



* R_S can be zero (shorted) when use with higher frequency crystals. Refer to manufacturer's data.

Figure 2-6 Full Swing Pierce Oscillator Connections (PE7=0)

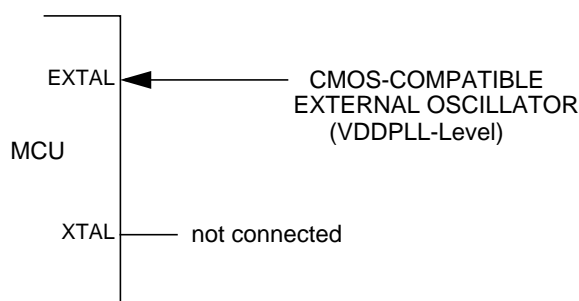

Figure 2-7 External Clock Connections (PE7=0)

2.3.12 PE6 / MODB / IPIPE1 — Port E I/O Pin 6

PE6 is a general purpose input or output pin. It is used as a MCU operating mode select pin during reset. The state of this pin is latched to the MODB bit at the rising edge of $\overline{\text{RESET}}$. This pin is shared with the instruction queue tracking signal IPIPE1.

2.3.13 PE5 / MODA / IPIPE0 — Port E I/O Pin 5

PE5 is a general purpose input or output pin. It is used as a MCU operating mode select pin during reset. The state of this pin is latched to the MODA bit at the rising edge of $\overline{\text{RESET}}$. This pin is shared with the instruction queue tracking signal IPIPE0.

2.3.14 PE4 / ECLK — Port E I/O Pin 4

PE4 is a general purpose input or output pin. It can be configured to drive the internal bus clock ECLK. ECLK can be used as a timing reference.

2.3.15 PE3 / $\overline{\text{LSTRB}}$ / $\overline{\text{TAGLO}}$ — Port E I/O Pin 3

PE3 is a general purpose input or output pin. In MCU expanded modes of operation, $\overline{\text{LSTRB}}$ can be used for the low-byte strobe function to indicate the type of bus access and when instruction tagging is on, $\overline{\text{TAGLO}}$ is used to tag the low half of the instruction word being read into the instruction queue.

2.3.16 PE2 / $\overline{\text{R/W}}$ — Port E I/O Pin 2

PE2 is a general purpose input or output pin. In MCU expanded modes of operations, this pin drives the read/write output signal for the external bus. It indicates the direction of data on the external bus.

2.3.17 PE1 / $\overline{\text{IRQ}}$ — Port E Input Pin 1

PE1 is a general purpose input pin and the maskable interrupt request input that provides a means of applying asynchronous interrupt requests. This will wake up the MCU from STOP or WAIT mode.

2.3.18 PE0 / $\overline{\text{XIRQ}}$ — Port E Input Pin 0

PE0 is a general purpose input pin and the non-maskable interrupt request input that provides a means of applying asynchronous interrupt requests. This will wake up the MCU from STOP or WAIT mode.

2.3.19 PH7 / $\overline{\text{KWH7}}$ / $\overline{\text{SS2}}$ — Port H I/O Pin 7

PH7 is a general purpose input or output pin. It can be configured to generate an interrupt causing the MCU to exit STOP or WAIT mode. It can be configured as slave select pin $\overline{\text{SS}}$ of the Serial Peripheral Interface 2 (SPI2).

2.3.20 PH6 / $\overline{\text{KWH6}}$ / $\overline{\text{SCK2}}$ — Port H I/O Pin 6

PH6 is a general purpose input or output pin. It can be configured to generate an interrupt causing the MCU to exit STOP or WAIT mode. It can be configured as serial clock pin SCK of the Serial Peripheral Interface 2 (SPI2).

2.3.21 PH5 / $\overline{\text{KWH5}}$ / $\overline{\text{MOSI2}}$ — Port H I/O Pin 5

PH5 is a general purpose input or output pin. It can be configured to generate an interrupt causing the MCU to exit STOP or WAIT mode. It can be configured as master output (during master mode) or slave input pin (during slave mode) MOSI of the Serial Peripheral Interface 2 (SPI2).

2.3.22 PH4 / $\overline{\text{KWH4}}$ / $\overline{\text{MISO2}}$ — Port H I/O Pin 2

PH4 is a general purpose input or output pin. It can be configured to generate an interrupt causing the MCU to exit STOP or WAIT mode. It can be configured as master input (during master mode) or slave output (during slave mode) pin MISO of the Serial Peripheral Interface 2 (SPI2).

2.3.23 PH3 / KWH3 / $\overline{SS1}$ — Port H I/O Pin 3

PH3 is a general purpose input or output pin. It can be configured to generate an interrupt causing the MCU to exit STOP or WAIT mode. It can be configured as slave select pin \overline{SS} of the Serial Peripheral Interface 1 (SPI1).

2.3.24 PH2 / KWH2 / SCK1 — Port H I/O Pin 2

PH2 is a general purpose input or output pin. It can be configured to generate an interrupt causing the MCU to exit STOP or WAIT mode. It can be configured as serial clock pin SCK of the Serial Peripheral Interface 1 (SPI1).

2.3.25 PH1 / KWH1 / MOSI1 — Port H I/O Pin 1

PH1 is a general purpose input or output pin. It can be configured to generate an interrupt causing the MCU to exit STOP or WAIT mode. It can be configured as master output (during master mode) or slave input pin (during slave mode) MOSI of the Serial Peripheral Interface 1 (SPI1).

2.3.26 PH0 / KWH0 / MISO1 — Port H I/O Pin 0

PH0 is a general purpose input or output pin. It can be configured to generate an interrupt causing the MCU to exit STOP or WAIT mode. It can be configured as master input (during master mode) or slave output (during slave mode) pin MISO of the Serial Peripheral Interface 1 (SPI1).

2.3.27 PJ7 / KWJ7 / TXCAN4 / SCL — PORT J I/O Pin 7

PJ7 is a general purpose input or output pin. It can be configured to generate an interrupt causing the MCU to exit STOP or WAIT mode. It can be configured as the transmit pin TXCAN for the Motorola Scalable Controller Area Network controller 4 (CAN4) or the serial clock pin SCL of the IIC module.

2.3.28 PJ6 / KWJ6 / RXCAN4 / SDA — PORT J I/O Pin 6

PJ6 is a general purpose input or output pin. It can be configured to generate an interrupt causing the MCU to exit STOP or WAIT mode. It can be configured as the receive pin RXCAN for the Motorola Scalable Controller Area Network controller 4 (CAN4) or the serial data pin SDA of the IIC module.

2.3.29 PJ[1:0] / KWJ[1:0] — Port J I/O Pins [1:0]

PJ1 and PJ0 are general purpose input or output pins. They can be configured to generate an interrupt causing the MCU to exit STOP or WAIT mode.

2.3.30 PK7 / \overline{ECS} / ROMCTL — Port K I/O Pin 7

PK7 is a general purpose input or output pin. During MCU expanded modes of operation, this pin is used as the emulation chip select output (\overline{ECS}). During MCU expanded modes of operation, this pin is used to

enable the Flash EEPROM memory in the memory map (ROMCTL). At the rising edge of $\overline{\text{RESET}}$, the state of this pin is latched to the ROMON bit. For all other modes the reset state of the ROMON bit is as follows:

special single : ROMCTL = 1

normal single : ROMCTL = 1

emulation expanded wide : ROMCTL = 0

emulation expanded narrow : ROMCTL = 0

special test : ROMCTL = 0

peripheral test : ROMCTL = 1

2.3.31 PK[5:0] / XADDR[19:14] — Port K I/O Pins [5:0]

PK5-PK0 are general purpose input or output pins. In MCU expanded modes of operation, these pins provide the expanded address XADDR[19:14] for the external bus.

2.3.32 PM7 / TXCAN4 — Port M I/O Pin 7

PM7 is a general purpose input or output pin. It can be configured as the transmit pin TXCAN of the Motorola Scalable Controller Area Network controllers 4 (CAN4).

2.3.33 PM6 / RXCAN4 — Port M I/O Pin 6

PM6 is a general purpose input or output pin. It can be configured as the receive pin RXCAN of the Motorola Scalable Controller Area Network controllers 4 (CAN4).

2.3.34 PM5 / TXCAN0 / TXCAN4 / SCK0 — Port M I/O Pin 5

PM5 is a general purpose input or output pin. It can be configured as the transmit pin TXCAN of the Motorola Scalable Controller Area Network controllers 0 or 4 (CAN0 or CAN4). It can be configured as the serial clock pin SCK of the Serial Peripheral Interface 0 (SPI0).

2.3.35 PM4 / RXCAN0 / RXCAN4/ MOSI0 — Port M I/O Pin 4

PM4 is a general purpose input or output pin. It can be configured as the receive pin RXCAN of the Motorola Scalable Controller Area Network controllers 0 or 4 (CAN0 or CAN4). It can be configured as the master output (during master mode) or slave input pin (during slave mode) MOSI for the Serial Peripheral Interface 0 (SPI0).

2.3.36 PM3 / TXCAN1 / TXCAN0 / \overline{SS} — Port M I/O Pin 3

PM3 is a general purpose input or output pin. It can be configured as the transmit pin TXCAN of the Motorola Scalable Controller Area Network controllers 1 or 0 (CAN1 or CAN0). It can be configured as the slave select pin \overline{SS} of the Serial Peripheral Interface 0 (SPI0).

2.3.37 PM2 / RXCAN1 / RXCAN0 / MISO0 — Port M I/O Pin 2

PM2 is a general purpose input or output pin. It can be configured as the receive pin RXCAN of the Motorola Scalable Controller Area Network controllers 1 or 0 (CAN1 or CAN0). It can be configured as the master input (during master mode) or slave output pin (during slave mode) MISO for the Serial Peripheral Interface 0 (SPI0).

2.3.38 PM1 / TXCAN0 — Port M I/O Pin 1

PM1 is a general purpose input or output pin. It can be configured as the transmit pin TXCAN of the Motorola Scalable Controller Area Network controller 0 (CAN0).

2.3.39 PM0 / RXCAN0 — Port M I/O Pin 0

PM0 is a general purpose input or output pin. It can be configured as the receive pin RXCAN of the Motorola Scalable Controller Area Network controller 0 (CAN0).

2.3.40 PP7 / KWP7 / PWM7 / SCK2 — Port P I/O Pin 7

PP7 is a general purpose input or output pin. It can be configured to generate an interrupt causing the MCU to exit STOP or WAIT mode. It can be configured as Pulse Width Modulator (PWM) channel 7 output. It can be configured as serial clock pin SCK of the Serial Peripheral Interface 2 (SPI2).

2.3.41 PP6 / KWP6 / PWM6 / \overline{SS} — Port P I/O Pin 6

PP6 is a general purpose input or output pin. It can be configured to generate an interrupt causing the MCU to exit STOP or WAIT mode. It can be configured as Pulse Width Modulator (PWM) channel 6 output. It can be configured as slave select pin \overline{SS} of the Serial Peripheral Interface 2 (SPI2).

2.3.42 PP5 / KWP5 / PWM5 / MOSI2 — Port P I/O Pin 5

PP5 is a general purpose input or output pin. It can be configured to generate an interrupt causing the MCU to exit STOP or WAIT mode. It can be configured as Pulse Width Modulator (PWM) channel 5 output. It can be configured as master output (during master mode) or slave input pin (during slave mode) MOSI of the Serial Peripheral Interface 2 (SPI2).

2.3.43 PP4 / KWP4 / PWM4 / MISO2 — Port P I/O Pin 4

PP4 is a general purpose input or output pin. It can be configured to generate an interrupt causing the MCU to exit STOP or WAIT mode. It can be configured as Pulse Width Modulator (PWM) channel 4 output. It can be configured as master input (during master mode) or slave output (during slave mode) pin MISO of the Serial Peripheral Interface 2 (SPI2).

2.3.44 PP3 / KWP3 / PWM3 / $\overline{SS1}$ — Port P I/O Pin 3

PP3 is a general purpose input or output pin. It can be configured to generate an interrupt causing the MCU to exit STOP or WAIT mode. It can be configured as Pulse Width Modulator (PWM) channel 3 output. It can be configured as slave select pin \overline{SS} of the Serial Peripheral Interface 1 (SPI1).

2.3.45 PP2 / KWP2 / PWM2 / SCK1 — Port P I/O Pin 2

PP2 is a general purpose input or output pin. It can be configured to generate an interrupt causing the MCU to exit STOP or WAIT mode. It can be configured as Pulse Width Modulator (PWM) channel 2 output. It can be configured as serial clock pin SCK of the Serial Peripheral Interface 1 (SPI1).

2.3.46 PP1 / KWP1 / PWM1 / MOSI1 — Port P I/O Pin 1

PP1 is a general purpose input or output pin. It can be configured to generate an interrupt causing the MCU to exit STOP or WAIT mode. It can be configured as Pulse Width Modulator (PWM) channel 1 output. It can be configured as master output (during master mode) or slave input pin (during slave mode) MOSI of the Serial Peripheral Interface 1 (SPI1).

2.3.47 PP0 / KWP0 / PWM0 / MISO1 — Port P I/O Pin 0

PP0 is a general purpose input or output pin. It can be configured to generate an interrupt causing the MCU to exit STOP or WAIT mode. It can be configured as Pulse Width Modulator (PWM) channel 0 output. It can be configured as master input (during master mode) or slave output (during slave mode) pin MISO of the Serial Peripheral Interface 1 (SPI1).

2.3.48 PS7 / $\overline{SS0}$ — Port S I/O Pin 7

PS6 is a general purpose input or output pin. It can be configured as the slave select pin \overline{SS} of the Serial Peripheral Interface 0 (SPI0).

2.3.49 PS6 / SCK0 — Port S I/O Pin 6

PS6 is a general purpose input or output pin. It can be configured as the serial clock pin SCK of the Serial Peripheral Interface 0 (SPI0).

2.3.50 PS5 / MOSI0 — Port S I/O Pin 5

PS5 is a general purpose input or output pin. It can be configured as master output (during master mode) or slave input pin (during slave mode) MOSI of the Serial Peripheral Interface 0 (SPI0).

2.3.51 PS4 / MISO0 — Port S I/O Pin 4

PS4 is a general purpose input or output pin. It can be configured as master input (during master mode) or slave output pin (during slave mode) MOSI of the Serial Peripheral Interface 0 (SPI0).

2.3.52 PS3 / TXD1 — Port S I/O Pin 3

PS3 is a general purpose input or output pin. It can be configured as the transmit pin TXD of Serial Communication Interface 1 (SCI1).

2.3.53 PS2 / RXD1 — Port S I/O Pin 2

PS2 is a general purpose input or output pin. It can be configured as the receive pin RXD of Serial Communication Interface 1 (SCI1).

2.3.54 PS1 / TXD0 — Port S I/O Pin 1

PS1 is a general purpose input or output pin. It can be configured as the transmit pin TXD of Serial Communication Interface 0 (SCI0).

2.3.55 PS0 / RXD0 — Port S I/O Pin 0

PS0 is a general purpose input or output pin. It can be configured as the receive pin RXD of Serial Communication Interface 0 (SCI0).

2.3.56 PT[7:0] / IOC[7:0] — Port T I/O Pins [7:0]

PT7-PT0 are general purpose input or output pins. They can be configured as input capture or output compare pins IOC7-IOC0 of the Timer (TIM).

2.4 Power Supply Pins

MC9S12K-Family power and ground pins are described below.

NOTE: *All VSS pins must be connected together in the application.*

2.4.1 VDDX, VSSX — Power Supply Pins for I/O Drivers

External power and ground for I/O drivers. Because fast signal transitions place high, short-duration current demands on the power supply, use bypass capacitors with high-frequency characteristics and place them as close to the MCU as possible. Bypass requirements depend on how heavily the MCU pins are loaded.

2.4.2 VDDR, VSSR — Power Supply Pins for I/O Drivers & for Internal Voltage Regulator

External power and ground for I/O drivers and input to the internal voltage regulator. Because fast signal transitions place high, short-duration current demands on the power supply, use bypass capacitors with high-frequency characteristics and place them as close to the MCU as possible. Bypass requirements depend on how heavily the MCU pins are loaded.

2.4.3 VDD1, VDD2, VSS1, VSS2 — Power Supply Pins for Internal Logic

Power is supplied to the MCU through VDD and VSS. Because fast signal transitions place high, short-duration current demands on the power supply, use bypass capacitors with high-frequency characteristics and place them as close to the MCU as possible. This 2.5V supply is derived from the internal voltage regulator. There is no static load on those pins allowed. The internal voltage regulator is turned off, if VREGEN is tied to ground.

NOTE: *No load allowed except for bypass capacitors.*

2.4.4 VDDA, VSSA — Power Supply Pins for ATD and VREG

VDDA, VSSA are the power supply and ground input pins for the voltage regulator and the analog to digital converter. It also provides the reference for the internal voltage regulator. This allows the supply voltage to the ATD and the reference voltage to be bypassed independently.

2.4.5 VRH, VRL — ATD Reference Voltage Input Pins

VRH and VRL are the reference voltage input pins for the analog to digital converter.

2.4.6 VDDPLL, VSSPLL — Power Supply Pins for PLL

Provides operating voltage and ground for the Oscillator and the Phased-Locked Loop. This allows the supply voltage to the Oscillator and PLL to be bypassed independently. This 2.5V voltage is generated by the internal voltage regulator.

NOTE: *No load allowed except for bypass capacitors.*

Section 3 System Clock Description

The Clock and Reset Generator provides the internal clock signals for the core and all peripheral modules. **Figure 3-1** shows the clock connections from the CRG to all modules. Consult the CRG Block Guide for details on clock generation.

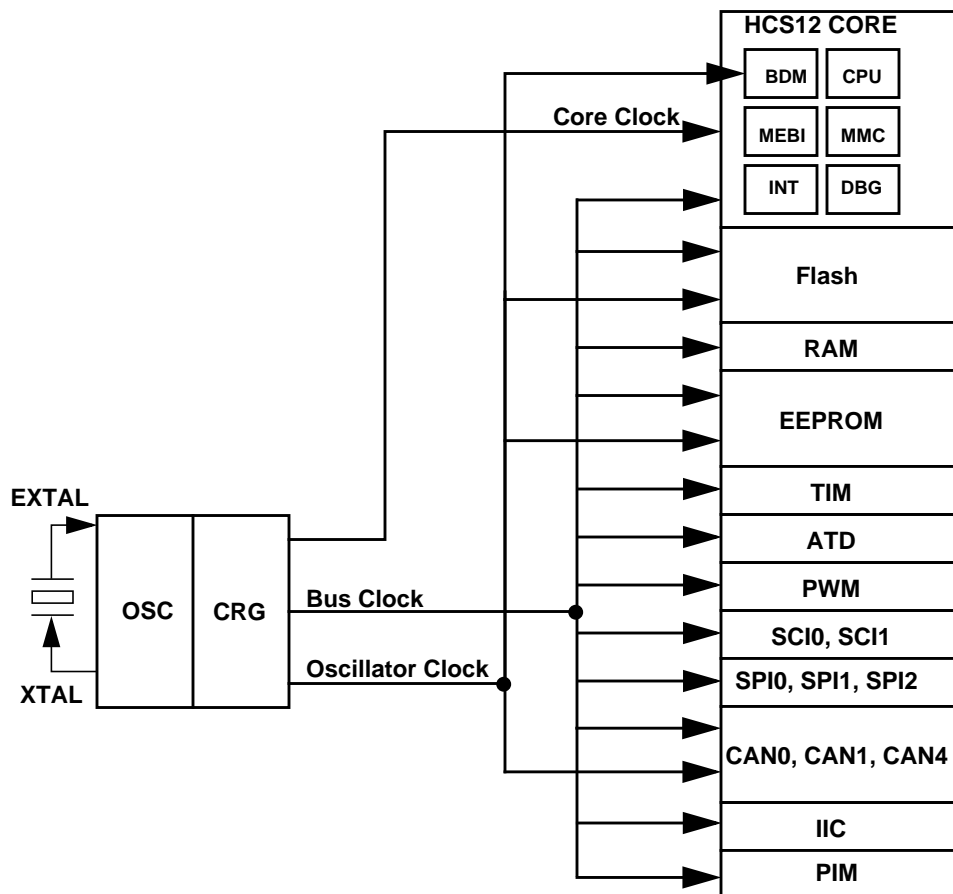

Figure 3-1 Clock Connections

Section 4 Modes of Operation

4.1 Overview

Eight possible modes determine the operating configuration of the MC9S12K-Family. Each mode has an associated default memory map and external bus configuration controlled by a further pin.

Three low power modes exist for the device.

4.2 Chip Configuration Summary

The operating mode out of reset is determined by the states of the MODC, MODB, and MODA pins during reset ((**Table 4-1**)). The MODC, MODB, and MODA bits in the MODE register show the current operating mode and provide limited mode switching during operation. The states of the MODC, MODB, and MODA pins are latched into these bits on the rising edge of the reset signal. The ROMCTL signal allows the setting of the ROMON bit in the MISC register thus controlling whether the internal Flash is visible in the memory map. ROMON = 1 mean the Flash is visible in the memory map. The state of the ROMCTL pin is latched into the ROMON bit in the MISC register on the rising edge of the reset signal.

Table 4-1 Mode Selection

BKGD = MODC	PE6 = MODB	PE5 = MODA	PK7 = ROMCTL	ROMON Bit	Mode Description
0	0	0	X	1	Special Single Chip, BDM allowed and ACTIVE. BDM is allowed in all other modes but a serial command is required to make BDM active.
0	0	1	0	1	Emulation Expanded Narrow, BDM allowed
			1	0	
0	1	0	X	0	Special Test (Expanded Wide), BDM allowed
0	1	1	0	1	Emulation Expanded Wide, BDM allowed
			1	0	
1	0	0	X	1	Normal Single Chip, BDM allowed
1	0	1	0	0	Normal Expanded Narrow, BDM allowed
			1	1	
1	1	0	X	1	Peripheral; BDM allowed but bus operations would cause bus conflicts (must not be used)
1	1	1	0	0	Normal Expanded Wide, BDM allowed
			1	1	

For further explanation on the modes refer to the HCS12 MEBI Block Guide.

Table 4-2 Clock Selection Based on PE7

PE7 = XCLKS	Description
1	Loop Controlled Pierce Oscillator selected
0	Full Swing Pierce Oscillator or external clock selected

Table 4-3 Voltage Regulator VREGEN

VREGEN	Description
1	Internal Voltage Regulator enabled
0	Internal Voltage Regulator disabled, VDD1,2 and VDDPLL must be supplied externally with 2.5V

4.3 Security

The device will make available a security feature preventing the unauthorized read and write of the memory contents. This feature allows:

- Protection of the contents of FLASH,
- Protection of the contents of EEPROM,
- Operation in single-chip mode,
- Operation from external memory with internal FLASH and EEPROM disabled.

The user must be reminded that part of the security must lie with the user's code. An extreme example would be user's code that dumps the contents of the internal program. This code would defeat the purpose of security. At the same time the user may also wish to put a back door in the user's program. An example of this is the user downloads a key through the SCI which allows access to a programming routine that updates parameters stored in EEPROM.

4.3.1 Securing the Microcontroller

Once the user has programmed the FLASH and EEPROM (if desired), the part can be secured by programming the security bits located in the FLASH module. These non-volatile bits will keep the part secured through resetting the part and through powering down the part.

The security byte resides in a portion of the Flash array.

Check the Flash Block Guide for more details on the security configuration.

4.3.2 Operation of the Secured Microcontroller

4.3.2.1 Normal Single Chip Mode

This will be the most common usage of the secured part. Everything will appear the same as if the part was not secured with the exception of BDM operation. The BDM operation will be blocked.

4.3.2.2 Executing from External Memory

The user may wish to execute from external space with a secured microcontroller. This is accomplished by resetting directly into expanded mode. The internal FLASH and EEPROM will be disabled. BDM operations will be blocked.

4.3.3 Unsecuring the Microcontroller

In order to unsecure the microcontroller, the internal FLASH and EEPROM must be erased. This can be done through an external program in expanded mode.

Once the user has erased the FLASH and EEPROM, the part can be reset into special single chip mode. This invokes a program that verifies the erasure of the internal FLASH and EEPROM. Once this program completes, the user can erase and program the FLASH security bits to the unsecured state. This is generally done through the BDM, but the user could also change to expanded mode (by writing the mode bits through the BDM) and jumping to an external program (again through BDM commands). Note that if the part goes through a reset before the security bits are reprogrammed to the unsecure state, the part will be secured again.

4.4 Low Power Modes

The microcontroller features three main low power modes. Consult the respective Block Guide for information on the module behavior in Stop, Pseudo Stop, and Wait Mode. An important source of information about the clock system is the Clock and Reset Generator Guide (CRG).

4.4.1 Stop

Executing the CPU STOP instruction stops all clocks and the oscillator thus putting the chip in fully static mode. Wake up from this mode can be done via reset or external interrupts.

4.4.2 Pseudo Stop

This mode is entered by executing the CPU STOP instruction. In this mode the oscillator is still running and the Real Time Interrupt (RTI) or Watchdog (COP) sub module can stay active. Other peripherals are turned off. This mode consumes more current than the full STOP mode, but the wake up time from this mode is significantly shorter.

4.4.3 Wait

This mode is entered by executing the CPU WAI instruction. In this mode the CPU will not execute instructions. The internal CPU signals (address and databus) will be fully static. All peripherals stay active. For further power consumption the peripherals can individually turn off their local clocks.

4.4.4 Run

Although this is not a low power mode, unused peripheral modules should not be enabled in order to save power.

Section 5 Resets and Interrupts

5.1 Overview

Consult the Exception Processing section of the CPU12 Reference Manual for information on resets and interrupts. Both local masking and CCR masking are included as listed in **Table 5-1**. System resets can be generated through external control of the $\overline{\text{RESET}}$ pin, through the clock and reset generator module CRG or through the low voltage reset (LVR) generator of the voltage regulator module. Refer to the CRG and VREG Block Guides for detailed information on reset generation.

5.2 Vectors

5.2.1 Vector Table

(**Table 5-1**) lists interrupt sources and vectors in default order of priority.

Table 5-1 Interrupt Vector Locations

Vector Address	Interrupt Source	CCR Mask	Local Enable	HPRIO Value to Elevate
\$FFFE, \$FFFF	External Reset, Power On Reset or Low Voltage Reset (see CRG Flags Register to determine reset source)	None	None	–
\$FFFC, \$FFFD	Clock Monitor fail reset	None	PLLCTL (CME, FCME)	–
\$FFFA, \$FFFB	COP failure reset	None	COP rate select	–
\$FFF8, \$FFF9	Unimplemented instruction trap	None	None	–
\$FFF6, \$FFF7	SWI	None	None	–
\$FFF4, \$FFF5	XIRQ	X-Bit	None	–
\$FFF2, \$FFF3	IRQ	I-Bit	IRQCR (IRQEN)	\$F2
\$FFF0, \$FFF1	Real Time Interrupt	I-Bit	CRGINT (RTIE)	\$F0
\$FFEE, \$FFEF	Standard Timer channel 0	I-Bit	TIE (C0I)	\$EE
\$FFEC, \$FFED	Standard Timer channel 1	I-Bit	TIE (C1I)	\$EC
\$FFEA, \$FFEB	Standard Timer channel 2	I-Bit	TIE (C2I)	\$EA
\$FFE8, \$FFE9	Standard Timer channel 3	I-Bit	TIE (C3I)	\$E8
\$FFE6, \$FFE7	Standard Timer channel 4	I-Bit	TIE (C4I)	\$E6
\$FFE4, \$FFE5	Standard Timer channel 5	I-Bit	TIE (C5I)	\$E4
\$FFE2, \$FFE3	Standard Timer channel 6	I-Bit	TIE (C6I)	\$E2
\$FFE0, \$FFE1	Standard Timer channel 7	I-Bit	TIE (C7I)	\$E0
\$FFDE, \$FFDF	Standard Timer overflow	I-Bit	TSCR2 (TOI)	\$DE
\$FFDC, \$FFDD	Pulse accumulator overflow	I-Bit	PACTL (PAOVI)	\$DC
\$FFDA, \$FFDB	Pulse accumulator input edge	I-Bit	PACTL (PAI)	\$DA
\$FFD8, \$FFD9	SPI0	I-Bit	SPICR1 (SPIE, SPTIE)	\$D8
\$FFD6, \$FFD7	SCI0	I-Bit	SCICR2 (TIE, TCIE, RIE, ILIE)	\$D6
\$FFD4, \$FFD5	SCI1	I-Bit	SCICR2 (TIE, TCIE, RIE, ILIE)	\$D4
\$FFD2, \$FFD3	ATD0	I-Bit	ATDCTL2 (ASCIE)	\$D2

\$FFD0, \$FFD1	ATD1	I-Bit	ATDCTL2 (ASCIE) ¹	\$D0
\$FFCE, \$FFCF	Port J	I-Bit	PIEJ (PIEJ7, PIEJ6, PIEJ1, PIEJ0)	\$CE
\$FFCC, \$FFCD	Port H	I-Bit	PIEH (PIEH7-0)	\$CC
\$FFCA, \$FFCB	Reserved	I-Bit	Reserved	\$CA
\$FFC8, \$FFC9		I-Bit		\$C8
\$FFC6, \$FFC7	CRG PLL lock	I-Bit	CRGINT (LOCKIE)	\$C6
\$FFC4, \$FFC5	CRG Self Clock Mode	I-Bit	CRGINT (SCMIE)	\$C4
\$FFC2, \$FFC3	FLASH Double Fault Detect	I-Bit	FCNFG (DFDIE)	\$C2
\$FFC0, \$FFC1	IIC Bus	I-Bit	IBCR (IBIE)	\$C0
\$FFBE, \$FFBF	SPI1	I-Bit	SPICR1 (SPIE, SPTIE)	\$BE
\$FFBC, \$FFBD	SPI2	I-Bit	SPICR1 (SPIE, SPTIE)	\$BC
\$FFBA, \$FFBB	EEPROM command	I-Bit	ECNFG (CCIE, CBEIE)	\$BA
\$FFB8, \$FFB9	FLASH command	I-Bit	FCNFG (CCIE, CBEIE)	\$B8
\$FFB6, \$FFB7	CAN0 wake-up	I-Bit	CAN0RIER (WUPIE)	\$B6
\$FFB4, \$FFB5	CAN0 errors	I-Bit	CAN0RIER (CSCIE, OVRIE)	\$B4
\$FFB2, \$FFB3	CAN0 receive	I-Bit	CAN0RIER (RXFIE)	\$B2
\$FFB0, \$FFB1	CAN0 transmit	I-Bit	CAN0TIER (TXEIE2 - TXEIE0)	\$B0
\$FFAE, \$FFAF	CAN1 wake-up	I-Bit	CAN1RIER (WUPIE) ¹	\$AE
\$FFAC, \$FFAD	CAN1 errors	I-Bit	CAN1RIER (CSCIE, OVRIE) ¹	\$AC
\$FFAA, \$FFAB	CAN1 receive	I-Bit	CAN1RIER (RXFIE) ¹	\$AA
\$FFA8, \$FFA9	CAN1 transmit	I-Bit	CAN1TIER (TXEIE2 - TXEIE0) ¹	\$A8
\$FFA6, \$FFA7	Reserved	I-Bit	Reserved	\$A6
\$FFA4, \$FFA5		I-Bit		\$A4
\$FFA2, \$FFA3		I-Bit		\$A2
\$FFA0, \$FFA1		I-Bit		\$A0
\$FF9E, \$FF9F		I-Bit		\$9E
\$FF9C, \$FF9D		I-Bit		\$9C
\$FF9A, \$FF9B		I-Bit		\$9A
\$FF98, \$FF99		I-Bit		\$98
\$FF96, \$FF97		CAN4 wake-up		I-Bit
\$FF94, \$FF95	CAN4 errors	I-Bit	CAN4RIER (CSCIE, OVRIE)	\$94
\$FF92, \$FF93	CAN4 receive	I-Bit	CAN4RIER (RXFIE)	\$92
\$FF90, \$FF91	CAN4 transmit	I-Bit	CAN4TIER (TXEIE2 - TXEIE0)	\$90
\$FF8E, \$FF8F	Port P	I-Bit	PIEP (PIEP7-0)	\$8E
\$FF8C, \$FF8D	PWM Emergency Shutdown	I-Bit	PWMSDN (PWMIE)	\$8C
\$FF8A, \$FF8B	VREG Low Voltage Interrupt	I-Bit	CTRL0 (LVIE)	\$8A
\$FF80 to \$FF89	Reserved			

NOTES:

1. Interrupt vector is only available on MC9S12KT256. Otherwise it is reserved.

5.3 Resets

Resets are a subset of the interrupts featured in **Table 5-1**. The different sources capable of generating a system reset are summarized in **Table 5-2**.

Table 5-2 Reset Summary

Reset	Priority	Source	Vector
Power-on Reset	1	CRG Module	\$FFFE, \$FFFF
External Reset	1	RESET pin	\$FFFE, \$FFFF
Low Voltage Reset	1	VREG Module	\$FFFE, \$FFFF
Clock Monitor Reset	2	CRG Module	\$FFFC, \$FFFD
COP Watchdog Reset	3	CRG Module	\$FFFA, \$FFFB

5.3.1 Effects of Reset

When a reset occurs, MCU registers and control bits are changed to known start-up states. Refer to the respective module Block Guides for register reset states. Refer to the HCS12 MEBI Block Guide for mode dependent pin configuration of port A, B and E out of reset.

Refer to the PIM Block Guide for reset configurations of all peripheral module ports.

Refer to **Table 1-2**(**Table 1-2**) for locations of the memories depending on the operating mode after reset.

The RAM array is not automatically initialized out of reset.

Section 6 HCS12 Core Block Description

6.1 CPU12 Block Description

Consult the CPU12 Reference Manual for information about the Central Processing Unit.

When the CPU12 Reference Manual refers to *cycles* this is equivalent to *Bus Clock periods*.

So *1 cycle* is equivalent to *1 Bus Clock period*.

6.2 HCS12 Background Debug Module (BDM) Block Description

Consult the HCS12 BDM Block Guide for information about the Background Debug Module.

When the BDM Block Guide refers to *alternate clock* this is equivalent to *Oscillator Clock*.

6.3 HCS12 Debug (DBG) Block Description

Consult the HCS12 DBG Block Guide for information about the Debug module.

6.4 HCS12 Interrupt (INT) Block Description

Consult the HCS12 INT Block Guide for information about the Interrupt module.

6.5 HCS12 Multiplexed External Bus Interface (MEBI) Block Description

Consult the HCS12 MEBI Block Guide for information about the Multiplexed External Bus Interface module.

6.6 HCS12 Module Mapping Control (MMC) Block Description

Consult the HCS12 MMC Block Guide for information about the Module Mapping Control module.

Section 7 Analog to Digital Converter (ATD) Block Description

Consult the ATD_10B16C Block Guide for further information about the A/D Converter module for the MC9S12KG128(64)(32), MC9S12KL128(64) and MC9S12KC128(64). When the ATD_10B16C Block Guide refers to *freeze mode* this is equivalent to *active BDM mode*.

Consult the ATD_10B8C Block Guide for further information about the A/D Converter module for the MC9S12KT256 and MC9S12KG256. When the ATD_10B8C Block Guide refers to *freeze mode* this is equivalent to *active BDM mode*.

Section 8 Clock Reset Generator (CRG) Block Description

Consult the CRG Block Guide for information about the Clock and Reset Generator module.

8.1 Device-specific information

The Low Voltage Reset feature uses the low voltage reset signal from the VREG module as an input to the CRG module. When the regulator output voltage supply to the internal chip logic falls below a specified threshold the LVR signal from the VREG module causes the CRG module to generate a reset. Consult the VREG Block Guide for voltage level specifications.

Section 9 EEPROM Block Description

Consult the EETS2K Block Guide for information about the EEPROM module for the MC9S12KG128(64)(32), MC9S12KL128(64) and MC9S12KC128(64).

Consult the EETS4K Block Guide for information about the EEPROM module for the MC9S12KT256 and MC9S12KG256.

Section 10 Flash EEPROM Block Description

Consult the FTS128K1ECC Block Guide for information about the flash module for the MC9S12KG128(64)(32), MC9S12KL128(64) and MC9S12KC128(64).

Consult the FTS256K2ECC Block Guide for information about the flash module for the MC9S12KT256 and MC9S12KG256.

The "S12 LRAE" is a generic Load RAM and Execute (LRAE) program which will be programmed into the flash memory of this device during manufacture. This LRAE program will provide greater programming flexibility to the end users by allowing the device to be programmed directly using SCI after it is assembled on the PCB. Use of the LRAE program is at the discretion of the end user and, if not required, it must simply be erased prior to flash programming. For more details of the S12 LRAE and its implementation, please see the S12 LREA Application Note (AN2546/D) .

It is planned that most HC9S12 devices manufactured after Q1 of 2004 will be shipped with the S12 LRAE programmed in the Flash . Exact details of the changeover (ie blank to programmed) for each product will be communicated in advance via GPCN and will be traceable by the customer via datecode marking on the device.

Please contact Motorola SPS Sales if you have any additional questions.

Section 11 IIC Block Description

Consult the IIC Block Guide for information about the Inter-IC Bus module.

Section 12 MSCAN Block Description

There are three MSCAN modules (CAN4, CAN1 and CAN0) implemented on the MC9S12KT256. There are only two MSCAN modules (CAN4 and CAN0) implemented on the MC9S12KG128(64)(32). There is only one MSCAN module (CAN0) implemented on the MC9S12KL128(64) and MC9S12KC128(64). Consult the MSCAN Block Guide for information about the Motorola Scalable CAN Module.

Section 13 OSC Block Description

Consult the OSC_LCP Block Guide for information about the Oscillator module.

Section 14 Port Integration Module (PIM) Block Description

Consult the PIM_9KG128 Block Guide for information about the Port Integration Module for the MC9S12KG128(64)(32), MC9S12KL128(64) and MC9S12KC128(64).

Consult the PIM_9KT256 Block Guide for information about the Port Integration Module for the MC9S12KT256 and MC9S12KG256.

Section 15 Pulse Width Modulator (PWM) Block Description

Consult the PWM_8B8C Block Guide for information about the Pulse Width Modulator Module. When the PWM_8B8C Block Guide refers to *freeze mode* this is equivalent to *active BDM mode*.

Section 16 Serial Communications Interface (SCI) Block Description

There are two Serial Communications Interface modules (SCI1 and SCI0). Consult the SCI Block Guide for information about the Serial Communications Interface module.

Section 17 Serial Peripheral Interface (SPI) Block Description

There are three Serial Peripheral Interfaces (SPI2, SPI1 and SPI0) implemented on MC9S12K-Family. Consult the SPI Block Guide for information about each Serial Peripheral Interface module.

Section 18 Timer (TIM) Block Description

Consult the TIM_16B8C Block Guide for information about the Timer module. When the TIM_16B8C Block Guide refers to *freeze mode* this is equivalent to *active BDM mode*.

Section 19 Voltage Regulator (VREG) Block Description

Consult the VREG_3V3 Block Guide for information about the dual output linear voltage regulator.

19.1 Device-specific information

19.1.1 VDD1, VDD2, VSS1, VSS2

In all package versions, both internal VDD and VSS of the 2.5V domain are bonded out on 2 sides of the device as two pin pairs (VDD1, VSS1 & VDD2, VSS2). VDD1 and VDD2 are connected together internally. VSS1 and VSS2 are connected together internally. This allows systems to employ better supply routing and further decoupling.

Appendix A Electrical Characteristics

A.1 General

NOTE: *The electrical characteristics given in this section are preliminary and should be used as a guide only. Values cannot be guaranteed by Motorola and are subject to change without notice.*

This supplement contains the most accurate electrical information for the MC9S12K-Family of microcontrollers available at the time of publication. The information should be considered **PRELIMINARY** and is subject to change.

This introduction is intended to give an overview on several common topics like power supply, current injection etc.

A.1.1 Parameter Classification

The electrical parameters shown in this supplement are guaranteed by various methods. To give the customer a better understanding the following classification is used and the parameters are tagged accordingly in the tables where appropriate.

NOTE: *This classification is shown in the column labeled “C” in the parameter tables where appropriate.*

P:

Those parameters are guaranteed during production testing on each individual device.

C:

Those parameters are achieved by the design characterization by measuring a statistically relevant sample size across process variations. They are regularly verified by production monitors.

T:

Those parameters are achieved by design characterization on a small sample size from typical devices. All values shown in the typical column are within this category.

D:

Those parameters are derived mainly from simulations.

A.1.2 Power Supply

The MC9S12K-Family utilizes several pins to supply power to the I/O ports, A/D converter, oscillator, PLL and internal logic.

The VDDA, VSSA pair supplies the A/D converter.

The VDDX, VSSX pair supplies the I/O pins

The VDDR, VSSR pair supplies the internal voltage regulator.

VDD1, VSS1, VDD2 and VSS2 are the supply pins for the digital logic.

VDDPLL, VSSPLL supply the oscillator and the PLL.

VSS1 and VSS2 are internally connected by metal.

VDD1 and VDD2 are internally connected by metal.

VDDA, VDDX, VDDR as well as VSSA, VSSX, VSSR are connected by anti-parallel diodes for ESD protection.

NOTE: *In the following context VDD5 is used for either VDDA, VDDR and VDDX; VSS5 is used for either VSSA, VSSR and VSSX unless otherwise noted. IDD5 denotes the sum of the currents flowing into the VDDA, VDDX and VDDR pins. VDD is used for VDD1, VDD2 and VDDPLL, VSS is used for VSS1, VSS2 and VSSPLL. IDD is used for the sum of the currents flowing into VDD1 and VDD2.*

A.1.3 Pins

There are four groups of functional pins.

A.1.3.1 3.3V/5V I/O pins

Those I/O pins have a nominal level of 3.3V or 5V depending on the application operating point. This group of pins is comprised of all port I/O pins, the analog inputs, BKGD pin and the RESET inputs. The internal structure of all those pins is identical, however some of the functionality may be disabled. E.g. for the analog inputs the output drivers, pull-up and pull-down resistors are disabled permanently.

A.1.3.2 Analog Reference

This group of pins is comprised of the VRH and VRL pins.

A.1.3.3 Oscillator

The pins EXTAL, XTAL dedicated to the oscillator have a nominal 2.5V level. They are supplied by VDDPLL.

A.1.3.4 PLL

The pin XFC dedicated to the oscillator have a nominal 2.5V level. It is supplied by VDDPLL.

A.1.3.5 TEST

This pin is used for production testing only.

A.1.4 Current Injection

Power supply must maintain regulation within operating V_{DD5} or V_{DD} range during instantaneous and operating maximum current conditions. If positive injection current ($V_{in} > V_{DD5}$) is greater than I_{DD5} , the injection current may flow out of VDD5 and could result in external power supply going out of regulation.

Insure external VDD5 load will shunt current greater than maximum injection current. This will be the greatest risk when the MCU is not consuming power; e.g. if no system clock is present, or if clock rate is very low which would reduce overall power consumption.

A.1.5 Absolute Maximum Ratings

Absolute maximum ratings are stress ratings only. A functional operation under or outside those maxima is not guaranteed. Stress beyond those limits may affect the reliability or cause permanent damage of the device.

This device contains circuitry protecting against damage due to high static voltage or electrical fields; however, it is advised that normal precautions be taken to avoid application of any voltages higher than maximum-rated voltages to this high-impedance circuit. Reliability of operation is enhanced if unused inputs are tied to an appropriate logic voltage level (e.g., either V_{SS5} or V_{DD5}).

Table A-1 Absolute Maximum Ratings

Num	Rating	Symbol	Min	Max	Unit
1	I/O, Regulator and Analog Supply Voltage	V_{DD5}	-0.3	6.5	V
2	Internal Logic Supply Voltage ¹	V_{DD}	-0.3	3.0	V
3	PLL Supply Voltage ⁽¹⁾	V_{DDPLL}	-0.3	3.0	V
4	Voltage difference VDDX to VDDR and VDDA	ΔV_{DDX}	-0.3	0.3	V
5	Voltage difference VSSX to VSSR and VSSA	ΔV_{SSX}	-0.3	0.3	V
6	Digital I/O Input Voltage	V_{IN}	-0.3	6.5	V
7	Analog Reference	V_{RH}, V_{RL}	-0.3	6.5	V
8	XFC, EXTAL, XTAL inputs	V_{ILV}	-0.3	3.0	V
9	TEST input	V_{TEST}	-0.3	10.0	V
10	Instantaneous Maximum Current Single pin limit for all digital I/O pins ²	I_D	-25	+25	mA
11	Instantaneous Maximum Current Single pin limit for XFC, EXTAL, XTAL ³	I_{DL}	-25	+25	mA
12	Instantaneous Maximum Current Single pin limit for TEST ⁴	I_{DT}	-0.25	0	mA
13	Operating Temperature Range (packaged)	T_A	-40	125	°C
14	Operating Temperature Range (junction)	T_J	-40	140	°C
15	Storage Temperature Range	T_{stg}	-65	155	°C

NOTES:

1. The device contains an internal voltage regulator to generate the logic and PLL supply out of the I/O supply. The absolute maximum ratings apply when the device is powered from an external source.
2. All digital I/O pins are internally clamped to V_{SSX} and V_{DDX} , V_{SSR} and V_{DDR} or V_{SSA} and V_{DDA} .
3. These pins are internally clamped to V_{SSPLL} and V_{DDPLL} .
4. This pin is clamped low to V_{SSR} , but not clamped high. This pin must be tied low in applications.

A.1.6 ESD Protection and Latch-up Immunity

All ESD testing is in conformity with CDF-AEC-Q100 Stress test qualification for Automotive Grade Integrated Circuits. During the device qualification ESD stresses were performed for the Human Body Model (HBM), the Machine Model (MM) and the Charge Device Model.

A device will be defined as a failure if after exposure to ESD pulses the device no longer meets the device specification. Complete DC parametric and functional testing is performed per the applicable device specification at room temperature followed by hot temperature, unless specified otherwise in the device specification.

Table A-2 ESD and Latch-up Test Conditions

Model	Description	Symbol	Value	Unit
Human Body	Series Resistance	R1	1500	Ohm
	Storage Capacitance	C	100	pF
	Number of Pulse per pin positive negative	-	- 3 3	
Machine	Series Resistance	R1	0	Ohm
	Storage Capacitance	C	200	pF
	Number of Pulse per pin positive negative	-	- 3 3	
Latch-up	Minimum input voltage limit		-2.5	V
	Maximum input voltage limit		7.5	V

Table A-3 ESD and Latch-Up Protection Characteristics

Num	C	Rating	Symbol	Min	Max	Unit
1	C	Human Body Model (HBM)	V_{HBM}	2000	-	V
2	C	Machine Model (MM)	V_{MM}	200	-	V
3	C	Charge Device Model (CDM)	V_{CDM}	500	-	V
4	C	Latch-up Current at 125°C positive negative	I_{LAT}	+100 -100	-	mA
5	C	Latch-up Current at 27°C positive negative	I_{LAT}	+200 -200	-	mA

A.1.7 Operating Conditions

This chapter describes the operating conditions of the device. Unless otherwise noted those conditions apply to all the following data.

NOTE: *Instead of specifying ambient temperature all parameters are specified for the more meaningful silicon junction temperature. For power dissipation calculations refer to Section A.1.8 Power Dissipation and Thermal Characteristics.*

Table A-4 Operating Conditions

Rating	Symbol	Min	Typ	Max	Unit
I/O, Regulator and Analog Supply Voltage	V_{DD5}	3.15	3.3/5	5.5	V
Internal Logic Supply Voltage ¹	V_{DD}	2.35	2.5	2.75	V
PLL Supply Voltage ⁽¹⁾	V_{DDPLL}	2.35	2.5	2.75	V
Voltage Difference VDDX to VDDA	ΔV_{DDX}	-0.1	0	0.1	V
Voltage Difference VSSX to VSSR and VSSA	ΔV_{SSX}	-0.1	0	0.1	V
Oscillator	f_{osc}	0.5	-	16	MHz
Bus Frequency	f_{bus}	0.5	-	25	MHz
MC9S12K-FamilyC/MC9S12KT256C					
Operating Junction Temperature Range	T_J	-40	-	100	°C
Operating Ambient Temperature Range ²	T_A	-40	27	85	°C
MC9S12K-FamilyV/MC9S12KT256V					
Operating Junction Temperature Range	T_J	-40	-	120	°C
Operating Ambient Temperature Range ⁽²⁾	T_A	-40	27	105	°C
MC9S12K-FamilyM/MC9S12KT256M					
Operating Junction Temperature Range	T_J	-40	-	140	°C
Operating Ambient Temperature Range ⁽²⁾	T_A	-40	27	125	°C

NOTES:

1. The device contains an internal voltage regulator to generate the logic and PLL supply out of the I/O supply. The absolute maximum ratings apply when this regulator is disabled and the device is powered from an external source.
2. Please refer to **Section A.1.8 Power Dissipation and Thermal Characteristics** for more details about the relation between ambient temperature T_A and device junction temperature T_J .

A.1.8 Power Dissipation and Thermal Characteristics

Power dissipation and thermal characteristics are closely related. The user must assure that the maximum operating junction temperature is not exceeded. The average chip-junction temperature (T_J) in °C can be obtained from:

$$T_J = T_A + (P_D \cdot \Theta_{JA})$$

T_J = Junction Temperature, [°C]

T_A = Ambient Temperature, [°C]

P_D = Total Chip Power Dissipation, [W]

Θ_{JA} = Package Thermal Resistance, [$^{\circ}\text{C}/\text{W}$]

The total power dissipation can be calculated from:

$$P_D = P_{INT} + P_{IO}$$

P_{INT} = Chip Internal Power Dissipation, [W]

Two cases with internal voltage regulator enabled and disabled must be considered:

1. Internal Voltage Regulator disabled

$$P_{INT} = I_{DD} \cdot V_{DD} + I_{DDPLL} \cdot V_{DDPLL} + I_{DDA} \cdot V_{DDA}$$

$$P_{IO} = \sum_i R_{DSON} \cdot I_{IO_i}^2$$

P_{IO} is the sum of all output currents on I/O ports associated with VDDX and VDDR.

For R_{DSON} is valid:

$$R_{DSON} = \frac{V_{OL}}{I_{OL}}; \text{for outputs driven low}$$

respectively

$$R_{DSON} = \frac{V_{DD5} - V_{OH}}{I_{OH}}; \text{for outputs driven high}$$

2. Internal voltage regulator enabled

$$P_{INT} = I_{DDR} \cdot V_{DDR} + I_{DDA} \cdot V_{DDA}$$

I_{DDR} is the current shown in **Table A-8** and not the overall current flowing into VDDR, which additionally contains the current flowing into the external loads with output high.

$$P_{IO} = \sum_i R_{DSON} \cdot I_{IO_i}^2$$

P_{IO} is the sum of all output currents on I/O ports associated with VDDX and VDDR.

Table A-5 Thermal Package Characteristics¹

Num	C	Rating	Symbol	Min	Typ	Max	Unit
1	T	Thermal Resistance LQFP112, single sided PCB ²	θ_{JA}	-	-	54	°C/W
2	T	Thermal Resistance LQFP112, double sided PCB with 2 internal planes ³	θ_{JA}	-	-	41	°C/W
3	T	Thermal Resistance QFP 80, single sided PCB	θ_{JA}	-	-	51	°C/W
4	T	Thermal Resistance QFP 80, double sided PCB with 2 internal planes	θ_{JA}	-	-	41	°C/W

NOTES:

1. The values for thermal resistance are achieved by package simulations
2. PC Board according to EIA/JEDEC Standard 51-2
3. PC Board according to EIA/JEDEC Standard 51-7

A.1.9 I/O Characteristics

This section describes the characteristics of all 3.3V/5V I/O pins. All parameters are not always applicable, e.g. not all pins feature pull up/down resistances.

Table A-6 5V I/O Characteristics

Conditions are shown in Table A-4 unless otherwise noted							
Num	C	Rating	Symbol	Min	Typ	Max	Unit
1	P	Input High Voltage	V_{IH}	$0.65 \cdot V_{DD5}$	-	$V_{DD5} + 0.3$	V
2	P	Input Low Voltage	V_{IL}	$V_{SS5} - 0.3$	-	$0.35 \cdot V_{DD5}$	V
3	C	Input Hysteresis	V_{HYS}		250		mV
4	P	Input Leakage Current (pins in high impedance input mode) $V_{in} = V_{DD5}$ or V_{SS5}	I_{in}	-2.5	-	2.5	μ A
5	P	Output High Voltage (pins in output mode) Partial Drive $I_{OH} = -2.0$ mA Full Drive $I_{OH} = -10.0$ mA	V_{OH}	$V_{DD5} - 0.8$	-	-	V
6	P	Output Low Voltage (pins in output mode) Partial Drive $I_{OL} = +2.0$ mA Full Drive $I_{OL} = +10.0$ mA	V_{OL}	-	-	0.8	V
7	P	Internal Pull Up Device Current, tested at V_{IL} Max.	I_{PUL}	-	-	-130	μ A
8	P	Internal Pull Up Device Current, tested at V_{IH} Min.	I_{PUH}	-10	-	-	μ A
9	P	Internal Pull Down Device Current, tested at V_{IH} Min.	I_{PDH}	-	-	130	μ A
10	P	Internal Pull Down Device Current, tested at V_{IL} Max.	I_{PDL}	10	-	-	μ A
11	D	Input Capacitance	C_{in}		7	-	pF
12	T	Injection current ¹ Single Pin limit Total Device Limit. Sum of all injected currents	I_{ICS} I_{ICP}	-2.5 -25	-	2.5 25	mA
13	P	Port H, J, P Interrupt Input Pulse filtered ²	t_{pign}			3	μ s
14	P	Port H, J, P Interrupt Input Pulse passed ⁽²⁾	t_{pval}	10			μ s

NOTES:

1. Refer to **Section A.1.4 Current Injection**, for more details
2. Parameter only applies in STOP or Pseudo STOP mode.

Table A-7 3.3V I/O Characteristics

Conditions are shown in Table A-4 unless otherwise noted							
Num	C	Rating	Symbol	Min	Typ	Max	Unit
1	P	Input High Voltage	V_{IH}	$0.65 \cdot V_{DD5}$	-	$V_{DD5} + 0.3$	V
2	P	Input Low Voltage	V_{IL}	$V_{SS5} - 0.3$	-	$0.35 \cdot V_{DD5}$	V
3	C	Input Hysteresis	V_{HYS}		250		mV
4	P	Input Leakage Current (pins in high impedance input mode) $V_{in} = V_{DD5}$ or V_{SS5}	I_{in}	-1	-	1	μA
5	P	Output High Voltage (pins in output mode) Partial Drive $I_{OH} = -0.75mA$ Full Drive $I_{OH} = -4.5mA$	V_{OH}	$V_{DD5} - 0.4$	-	-	V
6	P	Output Low Voltage (pins in output mode) Partial Drive $I_{OL} = +0.9mA$ Full Drive $I_{OL} = +5.5mA$	V_{OL}	-	-	0.4	V
7	P	Internal Pull Up Device Current, tested at V_{IL} Max.	I_{PUL}	-	-	-60	μA
8	P	Internal Pull Up Device Current, tested at V_{IH} Min.	I_{PUH}	-6	-	-	μA
9	P	Internal Pull Down Device Current, tested at V_{IH} Min.	I_{PDH}	-	-	60	μA
10	P	Internal Pull Down Device Current, tested at V_{IL} Max.	I_{PDL}	6	-	-	μA
11	D	Input Capacitance	C_{in}		7	-	pF
12	T	Injection current ¹ Single Pin limit Total Device Limit. Sum of all injected currents	I_{ICS} I_{ICP}	-2.5 -25	-	2.5 25	mA
13	P	Port P, J Interrupt Input Pulse filtered ²	t_{PULSE}			3	μs
14	P	Port P, J Interrupt Input Pulse passed ⁽²⁾	t_{PULSE}	10			μs

NOTES:

1. Refer to **Section A.1.4 Current Injection**, for more details
2. Parameter only applies in STOP or Pseudo STOP mode.

A.1.10 Supply Currents

This section describes the current consumption characteristics of the device as well as the conditions for the measurements.

A.1.10.1 Measurement Conditions

All measurements are without output loads. Unless otherwise noted the currents are measured in single chip mode, internal voltage regulator enabled and at 25MHz bus frequency using a 4MHz oscillator.

A.1.10.2 Additional Remarks

In expanded modes the currents flowing in the system are highly dependent on the load at the address, data and control signals as well as on the duty cycle of those signals. No generally applicable numbers can be given. A very good estimate is to take the single chip currents and add the currents due to the external loads.

Table A-8 Supply Current Characteristics

Conditions are shown in Table A-4 unless otherwise noted						
Num	Rating	Symbol	Min	Typ	Max	Unit
1	Run supply currents Single Chip, Internal regulator enabled	I_{DD5}			65	mA
2	Wait Supply current All modules enabled only RTI enabled ¹	I_{DDW}			40 5	mA
3	Pseudo Stop Current (RTI and COP enabled) ^{1,2} -40°C 27°C 70°C 85°C "C" Temp Option 100°C 105°C "V" Temp Option 120°C 125°C "M" Temp Option 140°C	I_{DDPS}		90 130 155 180 250 295 470 520 1000	350 1200 2400 5000	μA
4	Pseudo Stop Current (RTI and COP disabled) ^{1,2} -40°C 27°C 70°C 85°C "C" Temp Option 100°C 105°C "V" Temp Option 120°C 125°C "M" Temp Option 140°C	I_{DDPS}		40 80 105 130 200 245 420 470 800	200 1000 2000 5000	μA
5	Stop Current ² -40°C 27°C 70°C 85°C "C" Temp Option 100°C 105°C "V" Temp Option 120°C 125°C "M" Temp Option 140°C	I_{DD5}		20 60 85 110 180 225 400 450 600	100 800 1800 5000	μA

NOTES:

1. PLL off
2. All those low power dissipation levels $T_J = T_A$ can be assumed.

A.2 Voltage Regulator (VREG_3V3) Operating Characteristics

This section describes the characteristics of the on chip voltage regulator.

Table A-9 VREG_3V3 - Operating Conditions

Num	C	Characteristic	Symbol	Min	Typical	Max	Unit
1	P	Input Voltages	$V_{VDDR,A}$	3.15	—	5.5	V
2	P	Regulator Current Reduced Power Mode Shutdown Mode	I_{REG}	— —	20 12	50 40	μA μA
3	P	Output Voltage Core Full Performance Mode Reduced Power Mode Shutdown Mode ¹	V_{DD}	2.35 1.7 —	2.5 2.5 —	2.75 2.75 —	V V V
4	P	Output Voltage PLL Full Performance Mode Reduced Power Mode ² Shutdown Mode ⁽¹⁾	V_{DDPLL}	2.35 1.7 —	2.5 2.5 —	2.75 2.75 —	V V V
5	P	Low Voltage Interrupt ³ Assert Level Deassert Level	V_{LVIA} V_{LVID}	4.1 4.25	4.37 4.52	4.66 4.77	V V
5	P	Low Voltage Reset ⁴ Assert Level Deassert Level	V_{LVRA} $V_{LV RD}$	2.25 —	— —	— 2.55	V V
7	C	Power-on Reset ⁵ Assert Level Deassert Level	V_{PORA} V_{PORD}	0.97 —	— —	— 2.05	V V

NOTES:

1. High Impedance Output
2. Current $I_{DDPLL} = 500\mu A$
3. Monitors V_{DDA} , active only in Full Performance Mode. Indicates I/O & ADC performance degradation due to low supply voltage.
4. Monitors V_{DD} , active only in Full Performance Mode. V_{LVRA} and V_{PORD} must overlap
5. Monitors V_{DD} . Active in all modes.

NOTE: *The electrical characteristics given in this section are preliminary and should be used as a guide only. Values in this section cannot be guaranteed by Motorola and are subject to change without notice.*

A.3 Chip Power-up and LVI/LVR graphical explanation

Voltage regulator sub modules LVI (low voltage interrupt), POR (power-on reset) and LVR (low voltage reset) handle chip power-up or drops of the supply voltage. Their function is described in **Figure A-1**.

Figure A-1 Voltage Regulator - Chip Power-up and Voltage Drops (not scaled)

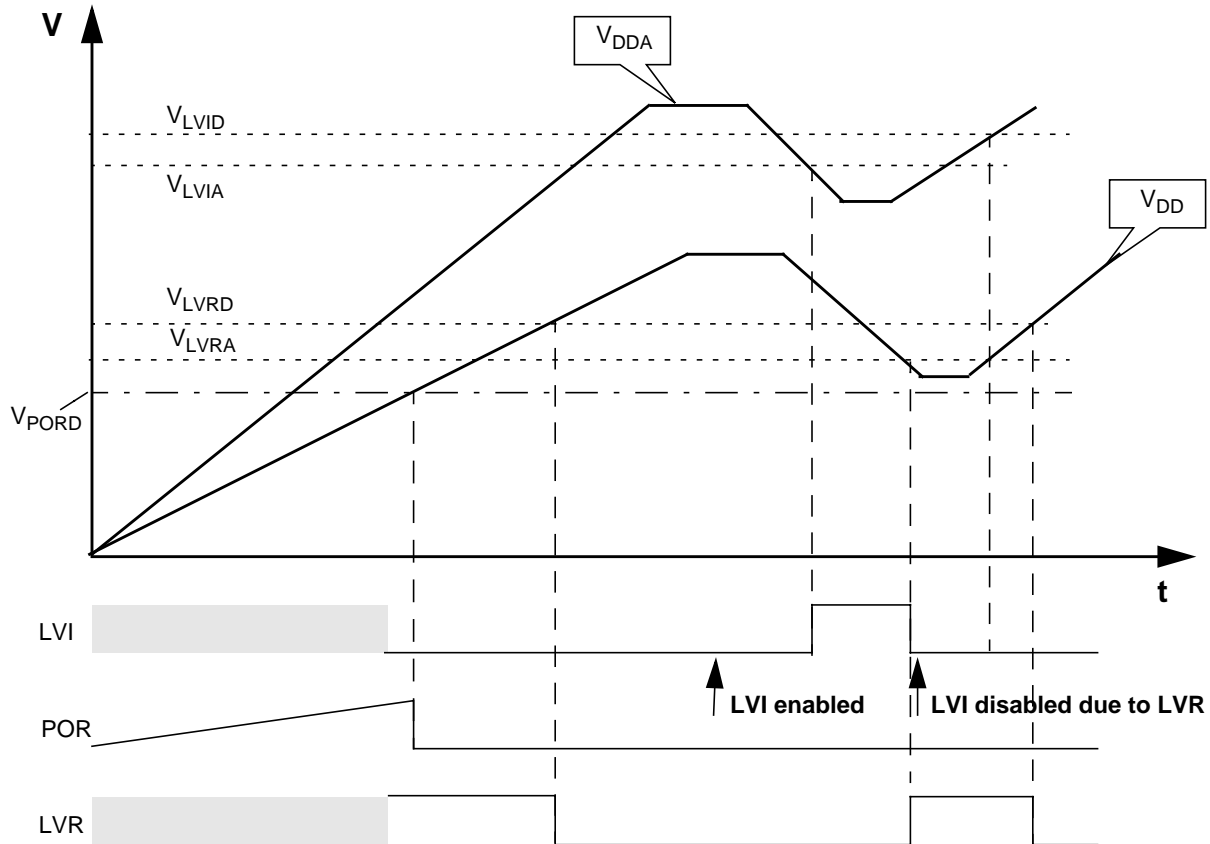

A.4 Output Loads

A.4.1 Resistive Loads

The on-chip voltage regulator is intended to supply the internal logic and oscillator circuits and allows no external DC loads.

A.4.2 Capacitive Loads

The capacitive loads are specified in **Table A-10**. Ceramic capacitors with X7R dielectricum are required.

Table A-10 Voltage Regulator - Capacitive Loads

Num	Characteristic	Symbol	Min	Typical	Max	Unit
1	VDD external capacitive load	C_{DDext}	200	440	12000	nF
2	VDDPLL external capacitive load	$C_{DDPLLext}$	90	220	5000	nF

A.5 ATD Characteristics

This section describes the characteristics of the analog to digital converter.

A.5.1 ATD Operating Characteristics

The **Table A-11** shows conditions under which the ATD operates.

The following constraints exist to obtain full-scale, full range results:

$VSSA \leq VRL \leq VIN \leq VRH \leq VDDA$. This constraint exists since the sample buffer amplifier can not drive beyond the power supply levels that it ties to. If the input level goes outside of this range it will effectively be clipped.

Table A-11 5V ATD Operating Characteristics

Conditions are shown in Table A-4 unless otherwise noted							
Num	C	Rating	Symbol	Min	Typ	Max	Unit
1	D	Reference Potential Low High	VRL VRH	VSSA VDDA/2		VDDA/2 VDDA	V V
2	C	Differential Reference Voltage ¹	VRH-VRL	4.75	5.0	5.25	V
3	D	ATD Clock Frequency	f _{ATDCLK}	0.5		2.0	MHz
4	D	ATD 10-Bit Conversion Period Clock Cycles ² Conv, Time at 2.0MHz ATD Clock f _{ATDCLK} Conv, Time at 4.0MHz ³ ATD Clock f _{ATDCLK}	N _{CONV10} T _{CONV10} T _{CONV10}	14 7 3.5		28 14 7	Cycles μs μs
5	D	ATD 8-Bit Conversion Period Clock Cycles ⁽¹⁾ Conv, Time at 2.0MHz ATD Clock f _{ATDCLK}	N _{CONV8} T _{CONV8}	12 6		26 13	Cycles μs
6	D	Stop Recovery Time (V _{DDA} =5.0 Volts)	t _{SR}			20	μs
7	P	Reference Supply current (two ATD modules)	I _{REF}			0.750	mA
8	P	Reference Supply current (one ATD module)	I _{REF}			0.375	mA

NOTES:

1. Full accuracy is not guaranteed when differential voltage is less than 4.75V
2. The minimum time assumes a final sample period of 2 ATD clocks cycles while the maximum time assumes a final sample period of 16 ATD clocks.
3. Reduced accuracy see **Table A-14** and **Table A-15**.

Table A-12 3.3V ATD Operating Characteristics

Conditions are shown in Table A-4 unless otherwise noted; Supply Voltage $3.3V-10\% \leq V_{DDA} \leq 3.3V+10\%$							
Num	C	Rating	Symbol	Min	Typ	Max	Unit
1	D	Reference Potential Low High	V_{RL} V_{RH}	V_{SSA} $V_{DDA}/2$		$V_{DDA}/2$ V_{DDA}	V V
2	C	Differential Reference Voltage	$V_{RH}-V_{RL}$	3.0	3.3	3.6	V
3	D	ATD Clock Frequency	f_{ATDCLK}	0.5		2.0	MHz
4	D	ATD 10-Bit Conversion Period Clock Cycles ¹ Conv, Time at 2.0MHz ATD Clock f_{ATDCLK} Conv, Time at 4.0MHz ² ATD Clock f_{ATDCLK}	N_{CONV10} T_{CONV10} T_{CONV10}	14 7 3.5		28 14 7	Cycles μs μs
5	D	ATD 8-Bit Conversion Period Clock Cycles ⁽¹⁾ Conv, Time at 2.0MHz ATD Clock f_{ATDCLK}	N_{CONV8} T_{CONV8}	12 6		26 13	Cycles μs
6	D	Recovery Time ($V_{DDA}=3.3$ Volts)	t_{REC}			20	μs
7	P	Reference Supply current (two ATD modules)	I_{REF}			0.500	mA
8	P	Reference Supply current (one ATD module)	I_{REF}			0.250	mA

NOTES:

1. The minimum time assumes a final sample period of 2 ATD clocks cycles while the maximum time assumes a final sample period of 16 ATD clocks.
2. Reduced accuracy see **Table A-14** and **Table A-15**.

A.5.2 Factors influencing accuracy

Three factors - source resistance, source capacitance and current injection - have an influence on the accuracy of the ATD.

A.5.2.1 Source Resistance:

Due to the input pin leakage current as specified in **Table A-6** and **Table A-7** in conjunction with the source resistance there will be a voltage drop from the signal source to the ATD input. The maximum source resistance R_S specifies results in an error of less than 1/2 LSB (2.5mV) at the maximum leakage current. If device or operating conditions are less than worst case or leakage-induced error is acceptable, larger values of source resistance are allowed.

A.5.2.2 Source capacitance

When sampling an additional internal capacitor is switched to the input. This can cause a voltage drop due to charge sharing with the external and the pin capacitance. For a maximum sampling error of the input voltage ≤ 1 LSB, then the external filter capacitor, $C_f \geq 1024 * (C_{INS} - C_{INN})$.

A.5.2.3 Current injection

There are two cases to consider.

1. A current is injected into the channel being converted. The channel being stressed has conversion values of \$3FF (\$FF in 8-bit mode) for analog inputs greater than VRH and \$000 for values less than VRL unless the current is higher than specified as disruptive conditions.
2. Current is injected into pins in the neighborhood of the channel being converted. A portion of this current is picked up by the channel (coupling ratio K), This additional current impacts the accuracy of the conversion depending on the source resistance.
The additional input voltage error on the converted channel can be calculated as $V_{ERR} = K * R_S * I_{INJ}$, with I_{INJ} being the sum of the currents injected into the two pins adjacent to the converted channel.

Table A-13 ATD Electrical Characteristics

Conditions are shown in Table A-4 unless otherwise noted						
Num	Rating	Symbol	Min	Typ	Max	Unit
1	Max input Source Resistance	R_S	-	-	1	K Ω
2	Total Input Capacitance Non Sampling Sampling	C_{INN} C_{INS}			10 22	pF
3	Disruptive Analog Input Current	I_{NA}	-2.5		2.5	mA
4	Coupling Ratio positive current injection	K_p			10^{-4}	A/A
5	Coupling Ratio negative current injection	K_n			10^{-2}	A/A

A.5.3 ATD accuracy

Table A-14 and **Table A-15** specify the ATD conversion performance excluding any errors due to current injection, input capacitance and source resistance.

Table A-14 5V ATD Conversion Performance

Conditions are shown in Table A-4 unless otherwise noted $V_{REF} = V_{RH} - V_{RL} = 5.12V$. Resulting to one 8 bit count = 20mV and one 10 bit count = 5mV $f_{ATDCLK} = 2.0MHz$							
Num	C	Rating	Symbol	Min	Typ	Max	Unit
1	P	10-Bit Resolution	LSB		5		mV
2	P	10-Bit Differential Nonlinearity	DNL	-1		1	Counts
3	P	10-Bit Integral Nonlinearity	INL	-2.5	± 1.5	2.5	Counts
4	P	10-Bit Absolute Error ¹	AE	-3	± 2.0	3	Counts
5	C	10-Bit Absolute Error at $f_{ATDCLK} = 4MHz$	AE		± 7.0		Counts
6	P	8-Bit Resolution	LSB		20		mV
7	P	8-Bit Differential Nonlinearity	DNL	-0.5		0.5	Counts
8	P	8-Bit Integral Nonlinearity	INL	-1.0	± 0.5	1.0	Counts
9	P	8-Bit Absolute Error ⁽¹⁾	AE	-1.5	± 1.0	1.5	Counts

NOTES:

1. These values include quantization error which is inherently 1/2 count for any A/D converter.

Table A-15 3.3V ATD Conversion Performance

Conditions are shown in Table A-4 unless otherwise noted $V_{REF} = V_{RH} - V_{RL} = 3.328V$. Resulting to one 8 bit count = 13mV and one 10 bit count = 3.25mV $f_{ATDCLK} = 2.0MHz$							
Num	C	Rating	Symbol	Min	Typ	Max	Unit
1	P	10-Bit Resolution	LSB		3.25		mV
2	P	10-Bit Differential Nonlinearity	DNL	-1.5		1.5	Counts
3	P	10-Bit Integral Nonlinearity	INL	-3.5	±1.5	3.5	Counts
4	P	10-Bit Absolute Error ¹	AE	-5	±2.5	5	Counts
5	C	10-Bit Absolute Error at $f_{ATDCLK} = 4MHz$	AE		±7.0		Counts
6	P	8-Bit Resolution	LSB		13		mV
7	P	8-Bit Differential Nonlinearity	DNL	-0.5		0.5	Counts
8	P	8-Bit Integral Nonlinearity	INL	-1.5	±0.1	1.5	Counts
9	P	8-Bit Absolute Error ⁽¹⁾	AE	-2.0	±1.5	2.0	Counts

NOTES:

1. These values include the quantization error which is inherently 1/2 count for any A/D converter.

For the following definitions see also **Figure A-2**.

Differential Non-Linearity (DNL) is defined as the difference between two adjacent switching steps.

$$DNL(i) = \frac{V_i - V_{i-1}}{1LSB} - 1$$

The Integral Non-Linearity (INL) is defined as the sum of all DNLs:

$$INL(n) = \sum_{i=1}^n DNL(i) = \frac{V_n - V_0}{1LSB} - n$$

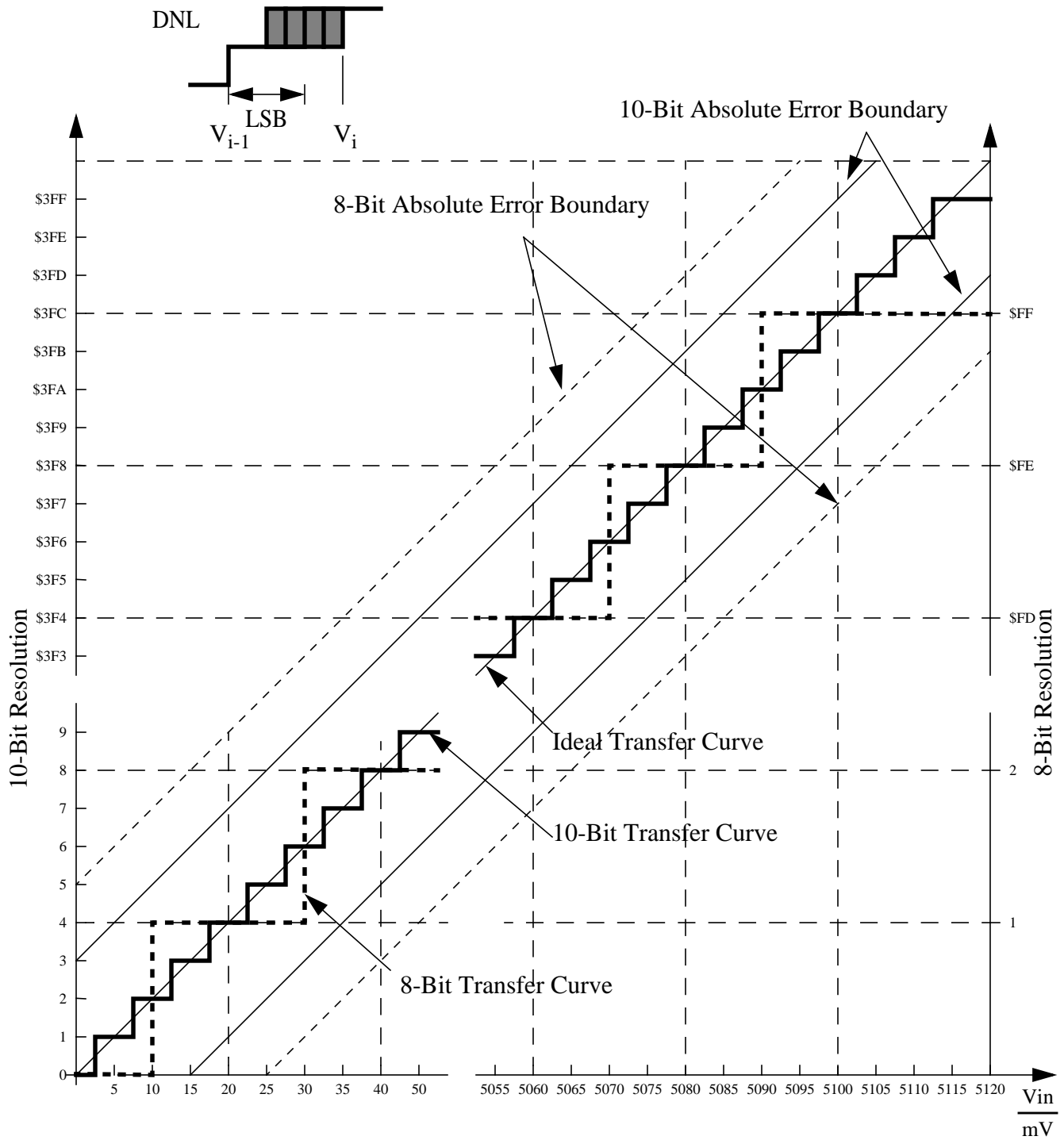

Figure A-2 ATD Accuracy Definitions

NOTE: Figure A-2 shows only definitions, for specification values refer to **Table A-14** and **Table A-15**.

A.6 NVM, Flash and EEPROM

NOTE: Unless otherwise noted the abbreviation NVM (Non Volatile Memory) is used for both Flash and EEPROM.

A.6.1 NVM timing

The time base for all NVM program or erase operations is derived from the oscillator. A minimum oscillator frequency f_{NVMOSC} is required for performing program or erase operations. The NVM modules do not have any means to monitor the frequency and will not prevent program or erase operation at frequencies above or below the specified minimum. Attempting to program or erase the NVM modules at a lower frequency a full program or erase transition is not assured.

The Flash and EEPROM program and erase operations are timed using a clock derived from the oscillator using the FCLKDIV and ECLKDIV registers respectively. The frequency of this clock must be set within the limits specified as f_{NVMOP} .

The minimum program and erase times shown in **Table A-16** are calculated for maximum f_{NVMOP} and maximum f_{bus} . The maximum times are calculated for minimum f_{NVMOP} and a f_{bus} of 2MHz.

A.6.1.1 Single Word Programming

The programming time for single word programming is dependant on the bus frequency as a well as on the frequency f_{NVMOP} and can be calculated according to the following formula.

$$t_{\text{swpgm}} = 9 \cdot \frac{1}{f_{\text{NVMOP}}} + 25 \cdot \frac{1}{f_{\text{bus}}}$$

A.6.1.2 Row Programming

Flash programming where up to 64 words in a row can be programmed consecutively by keeping the command pipeline filled. The time to program a consecutive word can be calculated as:

$$t_{\text{bwp gm}} = 4 \cdot \frac{1}{f_{\text{NVMOP}}} + 9 \cdot \frac{1}{f_{\text{bus}}}$$

The time to program a whole row is:

$$t_{\text{brpgm}} = t_{\text{swpgm}} + 63 \cdot t_{\text{bwp gm}}$$

Row programming is more than 2 times faster than single word programming.

A.6.1.3 Sector Erase

Erasing a 512 byte Flash sector or a 4 byte EEPROM sector takes:

$$t_{\text{era}} \approx 4000 \cdot \frac{1}{f_{\text{NVMOP}}}$$

The setup time can be ignored for this operation.

A.6.1.4 Mass Erase

Erasing a NVM block takes:

$$t_{\text{mass}} \approx 20000 \cdot \frac{1}{f_{\text{NVMOP}}}$$

The setup time can be ignored for this operation.

A.6.1.5 Blank Check

The time it takes to perform a blank check on the Flash or EEPROM is dependant on the location of the first non-blank word starting at relative address zero. It takes one bus cycle per word to verify plus a setup of the command.

$$t_{\text{check}} \approx \text{location} \cdot t_{\text{cyc}} + 10 \cdot t_{\text{cyc}}$$

Table A-16 NVM Timing Characteristics

Conditions are shown in Table A-4 unless otherwise noted							
Num	C	Rating	Symbol	Min	Typ	Max	Unit
1	D	External Oscillator Clock	f_{NVMOSC}	0.5		50 ¹	MHz
2	D	Bus frequency for Programming or Erase Operations	f_{NVMBUS}	1			MHz
3	D	Operating Frequency	f_{NVMOP}	150		200	kHz
4	P	Single Word Programming Time	t_{swpgm}	46 ²		74.5 ³	μs
5	D	Flash Burst Programming consecutive word ⁴	t_{bwpgm}	20.4 ⁽²⁾		31 ⁽³⁾	μs
6	D	Flash Burst Programming Time for 64 Words ⁽⁴⁾	t_{brpgm}	1331.2 ⁽²⁾		2027.5 ⁽³⁾	μs
7	P	Sector Erase Time	t_{era}	20 ⁵		26.7 ⁽³⁾	ms
8	P	Mass Erase Time	t_{mass}	100 ⁽⁵⁾		133 ⁽³⁾	ms
9	D	Blank Check Time Flash per block	t_{check}	11 ⁶		65546 ⁷	t_{cyc}
10	D	Blank Check Time EEPROM per block	t_{check}	11 ⁽⁶⁾		2058 ⁽⁷⁾	t_{cyc}

NOTES:

- Restrictions for oscillator in crystal mode apply!
- Minimum Programming times are achieved under maximum NVM operating frequency f_{NVMOP} and maximum bus frequency f_{bus} .
- Maximum Erase and Programming times are achieved under particular combinations of f_{NVMOP} and bus frequency f_{bus} . Refer to formula in Sections **Section A.6.1.1 Single Word Programming- Section A.6.1.4 Mass Erase** for guidance.
- Burst Programming operations are not applicable to EEPROM
- Minimum Erase times are achieved under maximum NVM operating frequency f_{NVMOP} .
- Minimum time, if first word in the array is not blank
- Maximum time to complete check on an erased block

A.6.2 NVM Reliability

The reliability of the NVM blocks is guaranteed by stress test during qualification, constant process monitors and burn-in to screen early life failures.

The failure rates for data retention and program/erase cycling are specified at the operating conditions noted.

The program/erase cycle count on the sector is incremented every time a sector or mass erase event is executed.

NOTE: All values shown in **Table A-17** are target values and subject to further extensive characterization.

Table A-17 NVM Reliability Characteristics

Conditions are shown in Table A-4 unless otherwise noted							
Num	C	Rating	Symbol	Min	Typ	Max	Unit
1	C	Data Retention at an average junction temperature of $T_{Javg} = 70^{\circ}\text{C}$	t_{NVMRET}	15			Years
2	C	Flash number of Program/Erase cycles	n_{FLPE}	1000	10,000		Cycles
3	C	EEPROM number of Program/Erase cycles ($-40^{\circ}\text{C} \leq T_J \leq 0^{\circ}\text{C}$)	n_{EEPE}	10,000			Cycles
4	C	EEPROM number of Program/Erase cycles ($0^{\circ}\text{C} < T_J \leq 140^{\circ}\text{C}$)	n_{EEPE}	100,000			Cycles

A.7 Reset, Oscillator and PLL

This section summarizes the electrical characteristics of the various startup scenarios for Oscillator and Phase-Locked-Loop (PLL).

A.7.1 Startup

Table A-18 summarizes several startup characteristics explained in this section. Detailed description of the startup behavior can be found in the Clock and Reset Generator (CRG) Block User Guide.

Table A-18 Startup Characteristics

Conditions are shown in Table A-4 unless otherwise noted							
Num	C	Rating	Symbol	Min	Typ	Max	Unit
1	T	POR release level	V_{PORR}			2.07	V
2	T	POR assert level	V_{PORA}	0.97			V
3	D	Reset input pulse width, minimum input time	PW_{RSTL}	2			t_{osc}
4	D	Startup from Reset	n_{RST}	192		196	n_{osc}
5	D	Interrupt pulse width, \overline{IRQ} edge-sensitive mode	PW_{IRQ}	20			ns
6	D	Wait recovery startup time	t_{WRS}			14	t_{cyc}

A.7.1.1 POR

The release level V_{PORR} and the assert level V_{PORA} are derived from the V_{DD} Supply. They are also valid if the device is powered externally. After releasing the POR reset the oscillator and the clock quality check are started. If after a time t_{CQOUT} no valid oscillation is detected, the MCU will start using the internal self clock. The fastest startup time possible is given by n_{uposc} .

A.7.1.2 SRAM Data Retention

Provided an appropriate external reset signal is applied to the MCU, preventing the CPU from executing code when V_{DD5} is out of specification limits, the SRAM contents integrity is guaranteed if after the reset the PORF bit in the CRG Flags Register has not been set.

A.7.1.3 External Reset

When external reset is asserted for a time greater than PW_{RSTL} the CRG module generates an internal reset, and the CPU starts fetching the reset vector without doing a clock quality check, if there was an oscillation before reset.

A.7.1.4 Stop Recovery

Out of STOP the controller can be woken up by an external interrupt. A clock quality check as after POR is performed before releasing the clocks to the system.

A.7.1.5 Pseudo Stop and Wait Recovery

The recovery from Pseudo STOP and Wait are essentially the same since the oscillator was not stopped in both modes. The controller can be woken up by internal or external interrupts. After t_{WRS} the CPU starts fetching the interrupt vector.

A.7.2 Oscillator

The device features an internal low-power loop controlled Pierce oscillator and a full swing Pierce oscillator/external clock mode. The selection of loop controlled Pierce oscillator or full swing Pierce oscillator/external clock depends on the XCLKS signal which is sampled during reset. Full swing Pierce oscillator/external clock mode allows the input of a square wave. Before asserting the oscillator to the internal system clocks the quality of the oscillation is checked for each start from either power-on, STOP or oscillator fail. t_{CQOUT} specifies the maximum time before switching to the internal self clock mode after POR or STOP if a proper oscillation is not detected. The quality check also determines the minimum oscillator start-up time t_{UPOSC} . The device also features a clock monitor. A Clock Monitor Failure is asserted if the frequency of the incoming clock signal is below the Assert Frequency f_{CMFA} .

Table A-19 Oscillator Characteristics

Conditions are shown in Table A-4 unless otherwise noted							
Num	C	Rating	Symbol	Min	Typ	Max	Unit
1a	C	Crystal oscillator range (loop controlled Pierce)	f_{OSC}	4.0		16	MHz
1b	C	Crystal oscillator range (full swing Pierce) ^{1,2}	f_{OSC}	0.5		40	MHz
2	P	Startup Current	i_{OSC}	100			μ A
3	C	Oscillator start-up time (loop controlled Pierce)	t_{UPOSC}		3 ³	50 ⁴	ms
4	D	Clock Quality check time-out	t_{CQOUT}	0.45		2.5	s
5	P	Clock Monitor Failure Assert Frequency	f_{CMFA}	50	100	200	KHz
6	P	External square wave input frequency ²	f_{EXT}	0.5		50	MHz
7	D	External square wave pulse width low	t_{EXTL}	9.5			ns
8	D	External square wave pulse width high	t_{EXTH}	9.5			ns
9	D	External square wave rise time	t_{EXTR}			1	ns
10	D	External square wave fall time	t_{EXTF}			1	ns
11	D	Input Capacitance (EXTAL, XTAL pins)	C_{IN}		7		pF
12	P	EXTAL Pin Input High Voltage	$V_{IH,EXTAL}$	0.7* V_{DDPLL}			V
	T	EXTAL Pin Input High Voltage	$V_{IH,EXTAL}$			$V_{DDPLL} + 0.3$	V
13	P	EXTAL Pin Input Low Voltage	$V_{IL,EXTAL}$			0.3* V_{DDPLL}	V
	T	EXTAL Pin Input Low Voltage	$V_{IL,EXTAL}$	$V_{SSPLL} - 0.3$			V
14	C	EXTAL Pin Input Hysteresis	$V_{HYS,EXTAL}$		250		mV

NOTES:

1. Depending on the crystal a damping series resistor might be necessary

2. Only valid if full swing Pierce oscillator/external clock mode is selected
3. $f_{OSC} = 4\text{MHz}$, $C = 22\text{pF}$.
4. Maximum value is for extreme cases using high Q, low frequency crystals

A.7.3 Phase Locked Loop

The oscillator provides the reference clock for the PLL. The PLL's Voltage Controlled Oscillator (VCO) is also the system clock source in self clock mode.

A.7.3.1 XFC Component Selection

This section describes the selection of the XFC components to achieve a good filter characteristics.

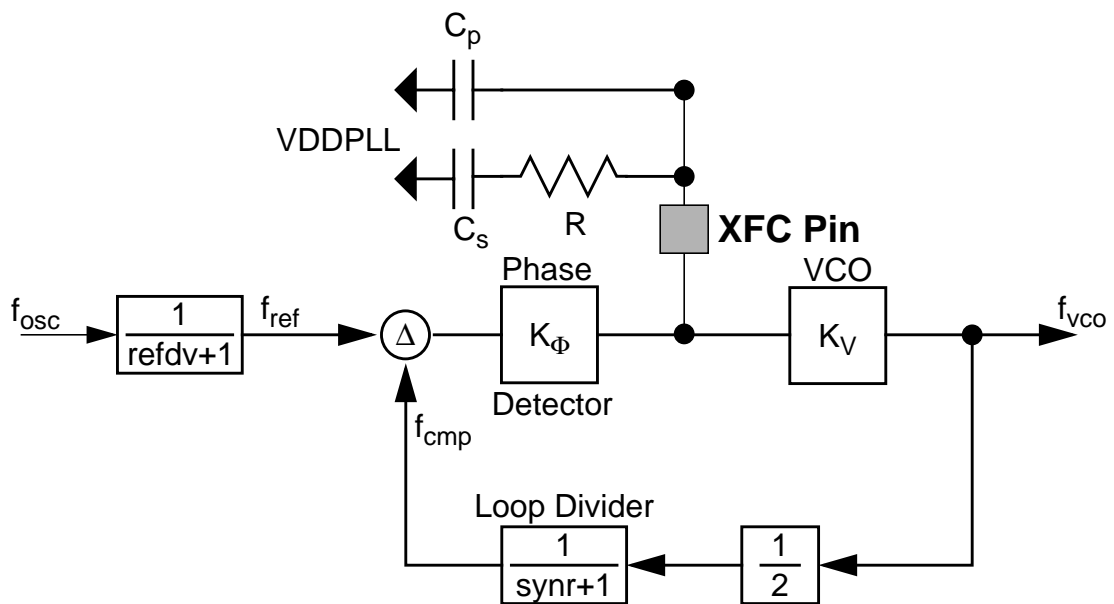

Figure A-3 Basic PLL functional diagram

The following procedure can be used to calculate the resistance and capacitance values using typical values for K_1 , f_1 and i_{ch} from **Table A-20**.

The grey boxes show the calculation for $f_{VCO} = 50\text{MHz}$ and $f_{ref} = 1\text{MHz}$. E.g., these frequencies are used for $f_{OSC} = 4\text{MHz}$ and a 25MHz bus clock.

The VCO Gain at the desired VCO frequency is approximated by:

$$K_V = K_1 \cdot e^{\frac{(f_1 - f_{VCO})}{K_1 \cdot 1V}} = -100 \cdot e^{\frac{(60 - 50)}{-100}} = -90.48\text{MHz/V}$$

The phase detector relationship is given by:

$$K_{\Phi} = -|i_{ch}| \cdot K_V = 316.7\text{Hz}/\Omega$$

i_{ch} is the current in tracking mode.

The loop bandwidth f_C should be chosen to fulfill the Gardner's stability criteria by at least a factor of 10, typical values are 50. $\zeta = 0.9$ ensures a good transient response.

$$f_C < \frac{2 \cdot \zeta \cdot f_{ref}}{\pi \cdot (\zeta + \sqrt{1 + \zeta^2})} \cdot \frac{1}{10} \rightarrow f_C < \frac{f_{ref}}{4 \cdot 10}; (\zeta = 0.9)$$

$$f_C < 25\text{kHz}$$

And finally the frequency relationship is defined as

$$n = \frac{f_{VCO}}{f_{ref}} = 2 \cdot (\text{synr} + 1) = 50$$

With the above values the resistance can be calculated. The example is shown for a loop bandwidth $f_C=10\text{kHz}$:

$$R = \frac{2 \cdot \pi \cdot n \cdot f_C}{K_{\Phi}} = 2 \cdot \pi \cdot 50 \cdot 10\text{kHz} / (316.7\text{Hz}/\Omega) = 9.9\text{k}\Omega \approx 10\text{k}\Omega$$

The capacitance C_s can now be calculated as:

$$C_s = \frac{2 \cdot \zeta^2}{\pi \cdot f_C \cdot R} \approx \frac{0.516}{f_C \cdot R}; (\zeta = 0.9) = 5.19\text{nF} \approx 4.7\text{nF}$$

The capacitance C_p should be chosen in the range of:

$$C_s/20 \leq C_p \leq C_s/10 \quad C_p = 470\text{pF}$$

A.7.3.2 Jitter Information

NOTE: This section is under construction

The basic functionality of the PLL is shown in **Figure A-3**. With each transition of the clock f_{cmp} , the deviation from the reference clock f_{ref} is measured and input voltage to the VCO is adjusted accordingly. The adjustment is done continuously with no abrupt changes in the clock output frequency. Noise, voltage, temperature and other factors cause slight variations in the control loop resulting in a clock jitter. This jitter affects the real minimum and maximum clock periods as illustrated in **Figure A-4**.

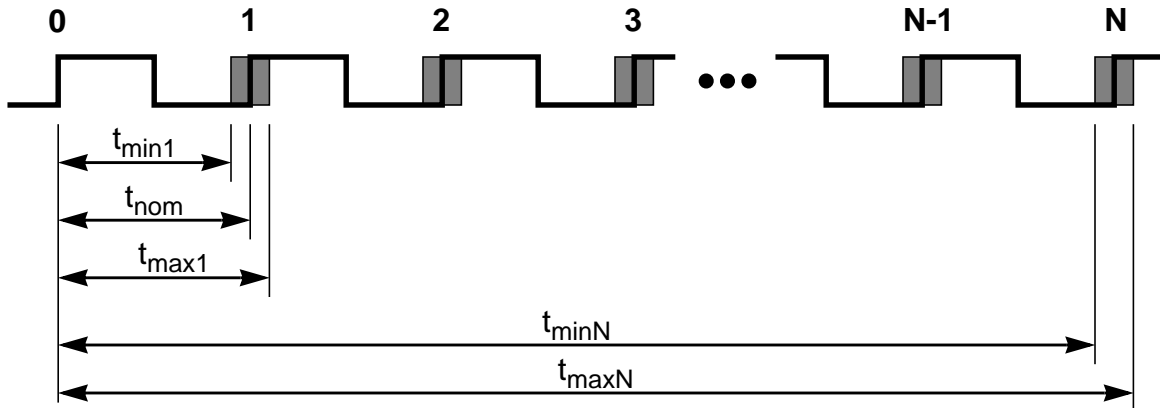

Figure A-4 Jitter Definitions

The relative deviation of t_{nom} is at its maximum for one clock period, and decreases towards zero for larger number of clock periods (N).

Defining the jitter as:

$$J(N) = \max\left(\left|1 - \frac{t_{\text{max}}(N)}{N \cdot t_{\text{nom}}}\right|, \left|1 - \frac{t_{\text{min}}(N)}{N \cdot t_{\text{nom}}}\right|\right)$$

NOTE: From the evaluation data a formula for $t_{\text{max}} = f(N)$, resp. $t_{\text{min}} = f(N)$ should be derived.

Assuming no long term drift of the reference clock, the following will hold

$$\lim_{N \rightarrow \infty} J(N) = 0$$

This is very important to notice with respect to timers, serial modules where a pre-scaler will eliminate the effect of the jitter to a large extent.

Table A-20 PLL Characteristics

Conditions are shown in Table A-4 unless otherwise noted							
Num	C	Rating	Symbol	Min	Typ	Max	Unit
1	P	Self Clock Mode frequency	f_{SCM}	1		5.5	MHz
2	D	VCO locking range	f_{VCO}	8		50	MHz
3	D	Lock Detector transition from Acquisition to Tracking mode	Δ_{trk}	3%		4% ¹	—
4	D	Lock Detection	Δ_{Lock}	0%		1.5% ⁽¹⁾	—
5	D	Un-Lock Detection	Δ_{unl}	0.5%		2.5% ⁽¹⁾	—
6	D	Lock Detector transition from Tracking to Acquisition mode	Δ_{unt}	6%		8% ⁽¹⁾	—
7	C	PLLON Total Stabilization delay ²	t_{stab}		0.5		ms
8	D	PLLON Acquisition mode stabilization delay ⁽²⁾	t_{acq}		0.3		ms
9	D	PLLON Tracking mode stabilization delay ⁽²⁾	t_{al}		0.2		ms
10	D	Fitting parameter VCO loop gain	K_1		-100		MHz/V
11	D	Fitting parameter VCO loop frequency	f_1		60		MHz
12	D	Charge pump current acquisition mode	i_{ch}		-38.5		μA
13	D	Charge pump current tracking mode	i_{ch}		-3.5		μA
14	C	Jitter fit parameter 1 ⁽²⁾	j_1			1.1	%
15	C	Jitter fit parameter 2 ⁽²⁾	j_2			0.13	%

NOTES:

1. % deviation from target frequency

2. $f_{OSC} = 4MHz$, $f_{BUS} = 25MHz$ equivalent $f_{VCO} = 50MHz$: $REFDV = \#03$, $SYNR = \#018$, $Cs = 4.7nF$, $Cp = 470pF$, $Rs = 10K\Omega$.

A.8 MSCAN

Table A-21 MSCAN Wake-up Pulse Characteristics

Conditions are shown in Table A-4 unless otherwise noted							
Num	C	Rating	Symbol	Min	Typ	Max	Unit
1	P	MSCAN Wake-up dominant pulse filtered	t_{WUP}			2	μs
2	P	MSCAN Wake-up dominant pulse pass	t_{WUP}	5			μs

A.9 SPI

A.9.1 Master Mode

Figure A-5 and Figure A-6 illustrate the master mode timing. Timing values are shown in Table A-22.

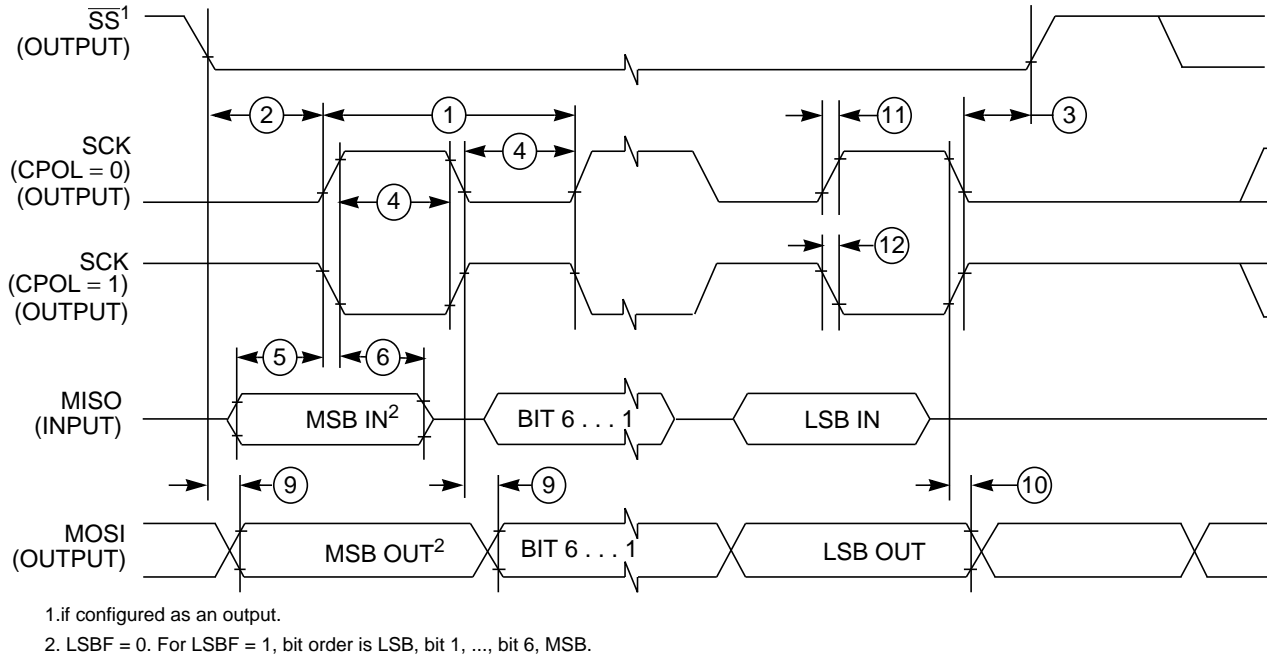
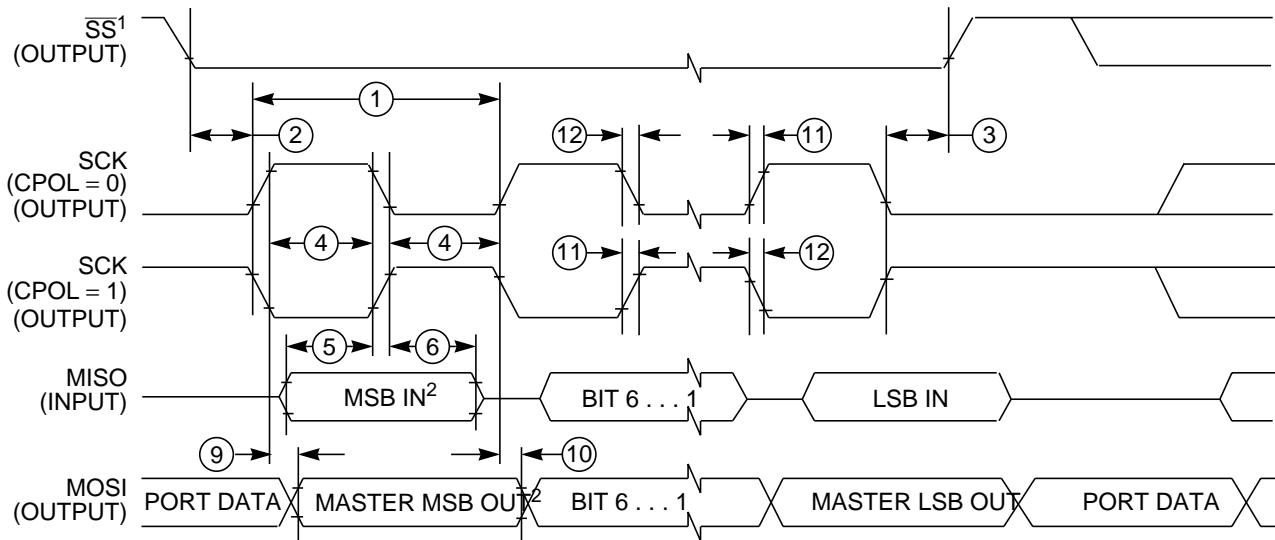

Figure A-5 SPI Master Timing (CPHA = 0)



- 1. If configured as output
- 2. LSBF = 0. For LSBF = 1, bit order is LSB, bit 1, ..., bit 6, MSB.

Figure A-6 SPI Master Timing (CPHA =1)

Table A-22 SPI Master Mode Timing Characteristics

Conditions are shown in **Table A-4** unless otherwise noted, CLOAD = 200pF on all outputs

Num	C	Rating	Symbol	Min	Typ	Max	Unit
1	P	Operating Frequency	f_{op}	DC		1/4	f_{bus}
1	P	SCK Period	t_{sck}	4		2048	t_{bus}
2	D	Enable Lead Time	t_{lead}	1/2		—	t_{sck}
3	D	Enable Lag Time	t_{lag}	1/2			t_{sck}
4	D	Clock (SCK) High or Low Time	t_{wsck}	$t_{bus} - 30$		$1024 t_{bus}$	ns
5	D	Data Setup Time (Inputs)	t_{su}	25			ns
6	D	Data Hold Time (Inputs)	t_{hi}	0			ns
9	D	Data Valid (after SCK Edge)	t_v			25	ns
10	D	Data Hold Time (Outputs)	t_{ho}	0			ns
11	D	Rise Time Inputs and Outputs	t_r			25	ns
12	D	Fall Time Inputs and Outputs	t_f			25	ns

A.9.2 Slave Mode

Figure A-7 and Figure A-8 illustrate the slave mode timing. Timing values are shown in Table A-23.

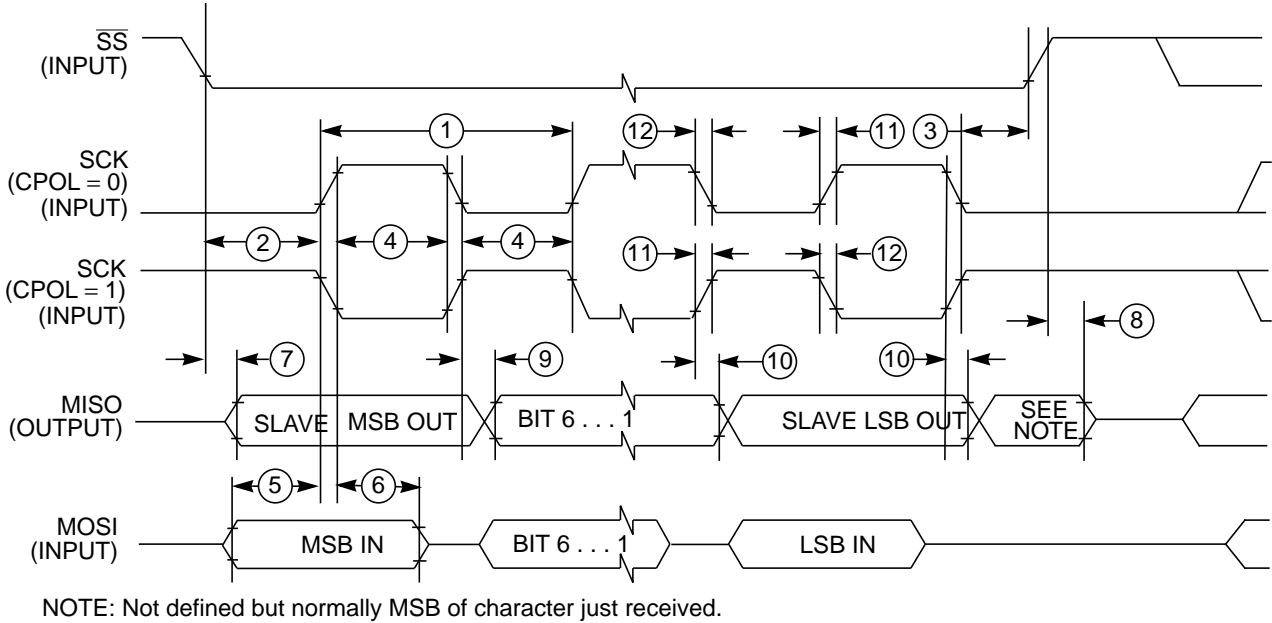

Figure A-7 SPI Slave Timing (CPHA = 0)

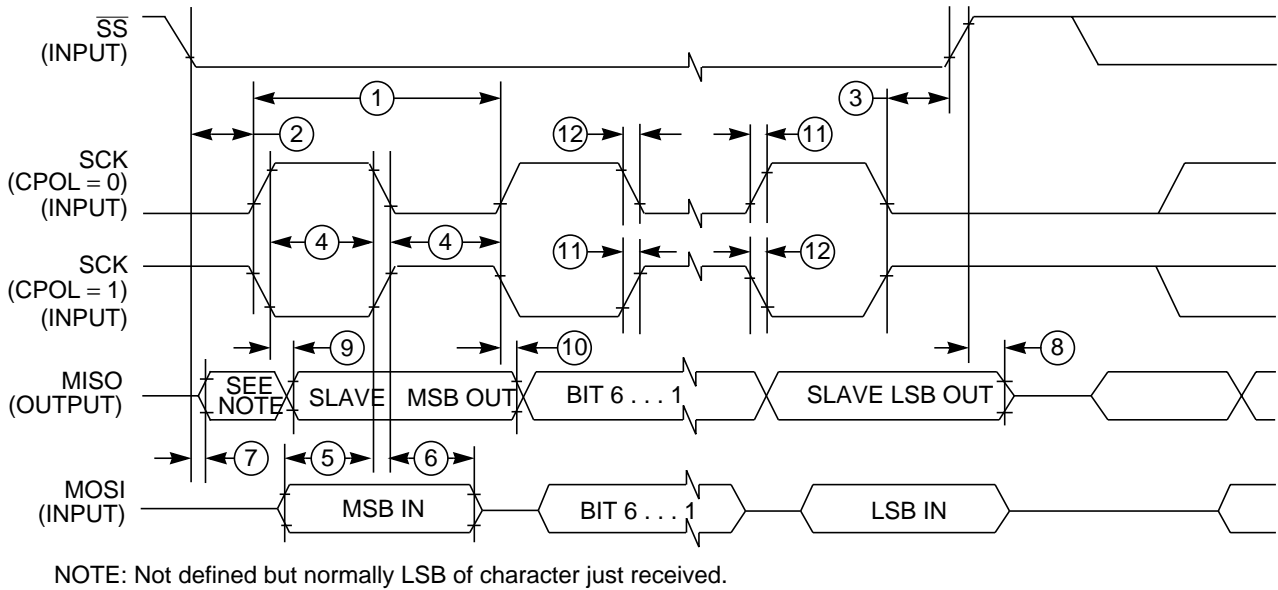

Figure A-8 SPI Slave Timing (CPHA = 1)

Table A-23 SPI Slave Mode Timing Characteristics

Conditions are shown in Table A-4 unless otherwise noted, CLOAD = 200pF on all outputs							
Num	C	Rating	Symbol	Min	Typ	Max	Unit
1	P	Operating Frequency	f_{op}	DC		1/4	f_{bus}
1	P	SCK Period	t_{sck}	4		2048	t_{bus}
2	D	Enable Lead Time	t_{lead}	1			t_{cyc}
3	D	Enable Lag Time	t_{lag}	1			t_{cyc}
4	D	Clock (SCK) High or Low Time	t_{wsck}	$t_{cyc} - 30$			ns
5	D	Data Setup Time (Inputs)	t_{su}	25			ns
6	D	Data Hold Time (Inputs)	t_{hi}	25			ns
7	D	Slave Access Time	t_a			1	t_{cyc}
8	D	Slave MISO Disable Time	t_{dis}			1	t_{cyc}
9	D	Data Valid (after SCK Edge)	t_v			25	ns
10	D	Data Hold Time (Outputs)	t_{ho}	0			ns
11	D	Rise Time Inputs and Outputs	t_r			25	ns
12	D	Fall Time Inputs and Outputs	t_f			25	ns

A.10 External Bus Timing

A timing diagram of the external multiplexed-bus is illustrated in **Figure A-9** with the actual timing values shown on table **Table A-24**. All major bus signals are included in the diagram. While both a data write and data read cycle are shown, only one or the other would occur on a particular bus cycle.

A.10.1 General Muxed Bus Timing

The expanded bus timings are highly dependent on the load conditions. The timing parameters shown assume a balanced load across all outputs.

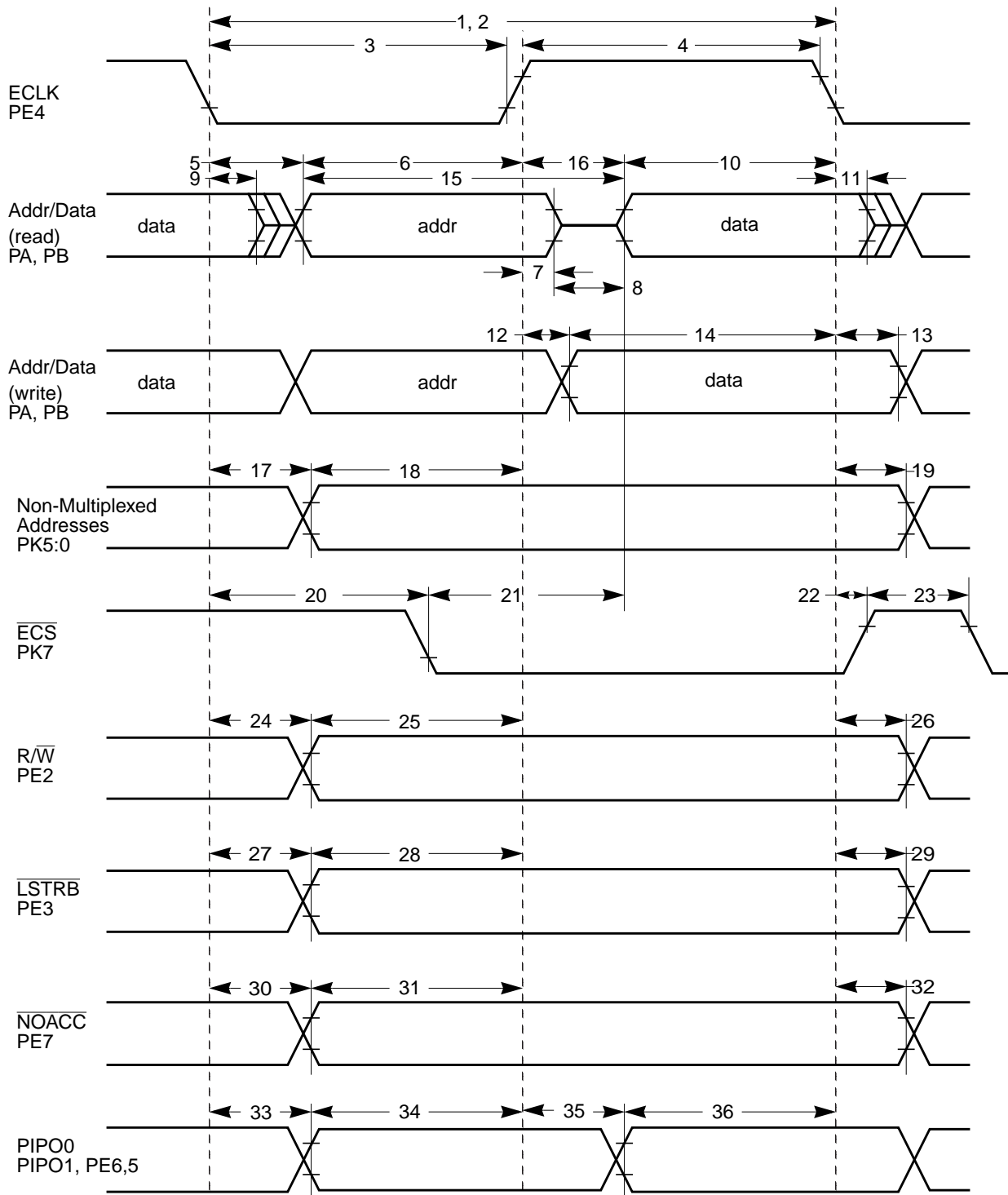

Figure A-9 General External Bus Timing

Table A-24 Expanded Bus Timing Characteristics

Conditions are shown in Table A-4 unless otherwise noted, $C_{LOAD} = 50pF$							
Num	C	Rating	Symbol	Min	Typ	Max	Unit
1	P	Frequency of operation (E-clock)	f_o	0		25.0	1
2	P	Cycle time	t_{cyc}	40			2
3	D	Pulse width, E low	PW_{EL}	17			3
4	D	Pulse width, E high ¹	PW_{EH}	17			4
5	D	Address delay time	t_{AD}			8	5
6	D	Address valid time to E rise ($PW_{EL}-t_{AD}$)	t_{AV}	11			6
7	D	Muxed address hold time	t_{MAH}	2			7
8	D	Address hold to data valid	t_{AHDS}	7			8
9	D	Data hold to address	t_{DHA}	2			9
10	D	Read data setup time	t_{DSR}	13			10
11	D	Read data hold time	t_{DHR}	0			11
12	D	Write data delay time	t_{DDW}			7	12
13	D	Write data hold time	t_{DHW}	2			13
14	D	Write data setup time ⁽¹⁾ ($PW_{EH}-t_{DDW}$)	t_{DSW}	10			14
15	D	Address access time ⁽¹⁾ ($t_{cyc}-t_{AD}-t_{DSR}$)	t_{ACCA}	19			15
16	D	E high access time ⁽¹⁾ ($PW_{EH}-t_{DSR}$)	t_{ACCE}	4			16
17	D	Non-multiplexed address delay time	t_{NAD}			7	17
18	D	Non-muxed address valid to E rise ($PW_{EL}-t_{NAD}$)	t_{NAV}	10			18
19	D	Non-multiplexed address hold time	t_{NAH}	2			19
20	D	Chip select delay time	t_{CSD}			16	20
21	D	Chip select access time ⁽¹⁾ ($t_{cyc}-t_{CSD}-t_{DSR}$)	t_{ACCS}	11			21
22	D	Chip select hold time	t_{CSH}	2			22
23	D	Chip select negated time	t_{CSN}	8			23
24	D	Read/write delay time	t_{RWD}			7	24
25	D	Read/write valid time to E rise ($PW_{EL}-t_{RWD}$)	t_{RWV}	10			25
26	D	Read/write hold time	t_{RWH}	2			26
27	D	Low strobe delay time	t_{LSD}			7	27
28	D	Low strobe valid time to E rise ($PW_{EL}-t_{LSD}$)	t_{LSV}	10			28
29	D	Low strobe hold time	t_{LSH}	2			29
30	D	NOACC strobe delay time	t_{NOD}			7	30
31	D	NOACC valid time to E rise ($PW_{EL}-t_{LSD}$)	t_{NOV}	10			31

Table A-24 Expanded Bus Timing Characteristics

Conditions are shown in Table A-4 unless otherwise noted, $C_{LOAD} = 50pF$							
32	D	NOACC hold time	t_{NOH}	2			32
33	D	PIPO0 delay time	t_{P0D}	2		7	33
34	D	PIPO0 valid time to E rise ($PW_{EL} - t_{P0D}$)	t_{P0V}	10			34
35	D	PIPO1 delay time ⁽¹⁾ ($PW_{EH} - t_{P1V}$)	t_{P1D}	2		7	35
36	D	PIPO1 valid time to E fall	t_{P1V}	10			36

NOTES:

1. Affected by clock stretch: add $N \times t_{cyc}$ where $N=0,1,2$ or 3 , depending on the number of clock stretches.

Appendix B Package Information

This section provides the physical dimensions of the MC9S12K-Family packages.

B.1 80-pin QFP package

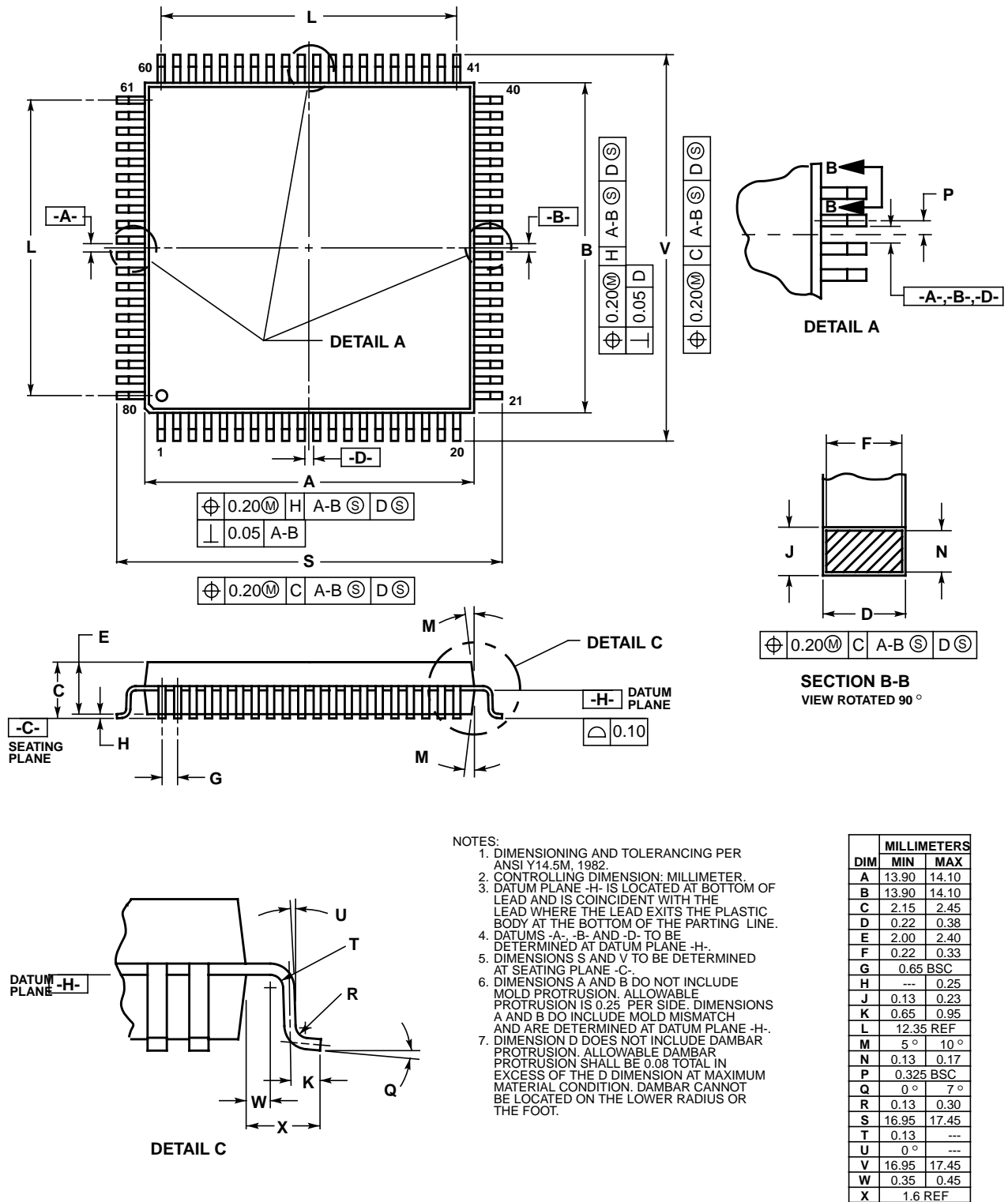
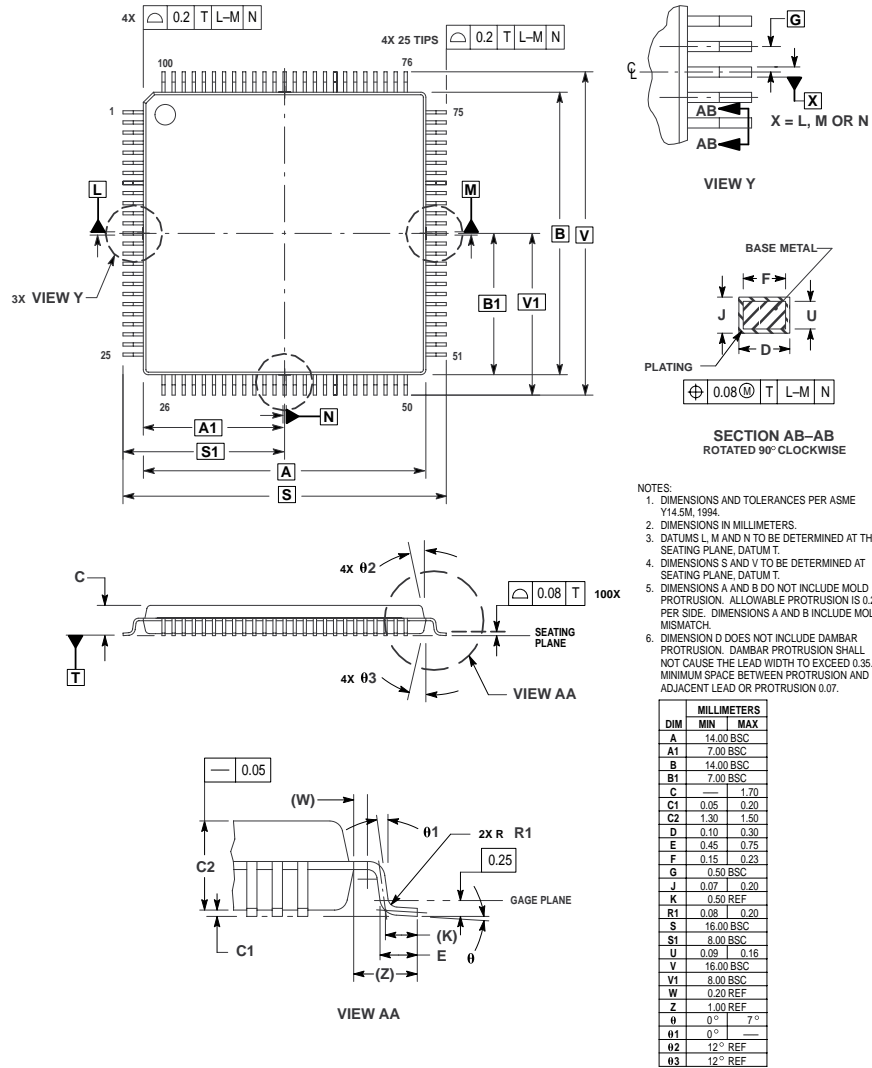

Figure B-1 80-pin QFP Mechanical Dimensions (case no. 841B)

B.2 100-pin LQFP package



CASE 983-02
ISSUE E

DATE 01/30/96

Figure B-2 100-pin LQFP Mechanical Dimensions (case no. 983)

B.3 112-pin LQFP package

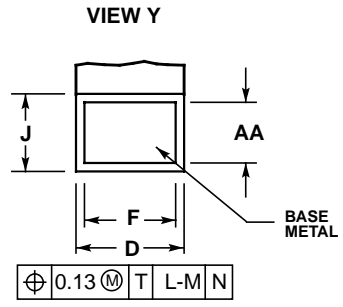
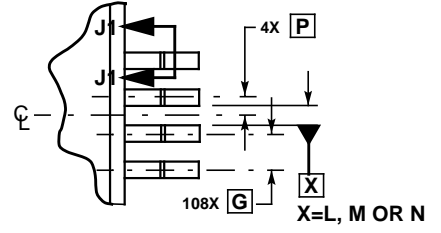
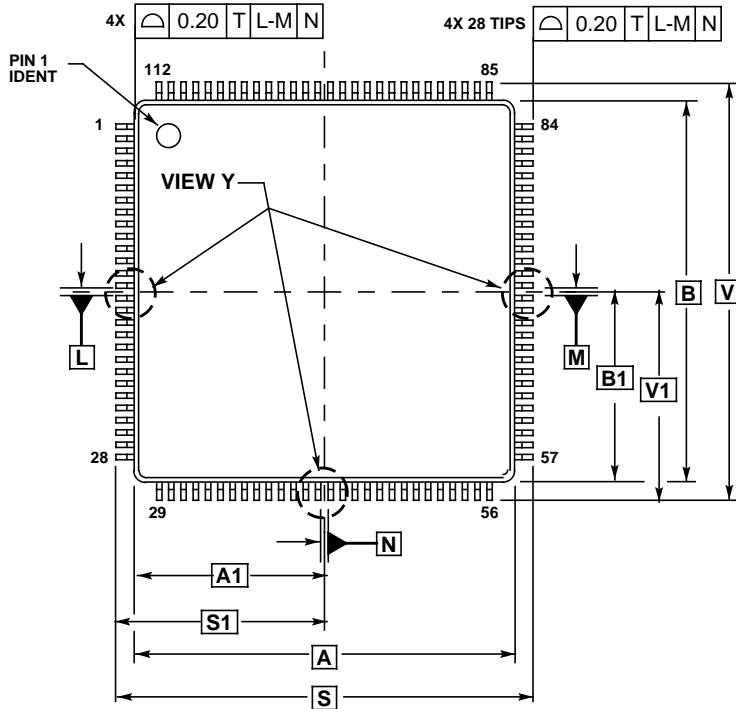

- NOTES:
1. DIMENSIONING AND TOLERANCING PER ASME Y14.5M, 1994.
 2. DIMENSIONS IN MILLIMETERS.
 3. DATUMS L, M AND N TO BE DETERMINED AT SEATING PLANE, DATUM T.
 4. DIMENSIONS S AND V TO BE DETERMINED AT SEATING PLANE, DATUM T.
 5. DIMENSIONS A AND B DO NOT INCLUDE MOLD PROTRUSION. ALLOWABLE PROTRUSION IS 0.25 PER SIDE.
 6. DIMENSION D DOES NOT INCLUDE DAMBAR

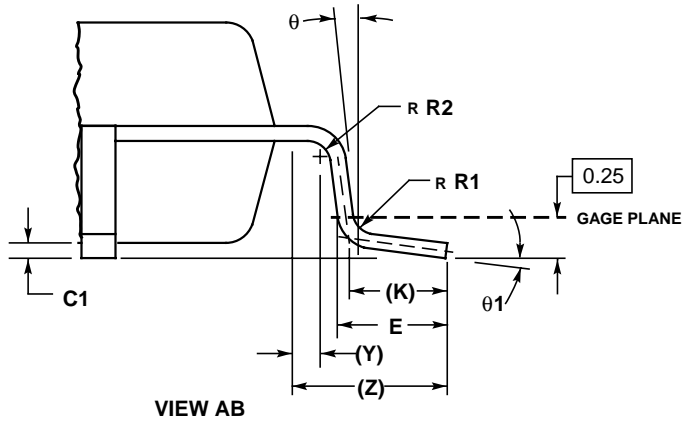
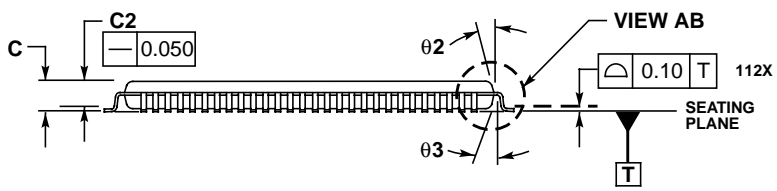

DIM	MILLIMETERS	
	MIN	MAX
A	20.000	BSC
A1	10.000	BSC
B	20.000	BSC
B1	10.000	BSC
C	---	1.600
C1	0.050	0.150
C2	1.350	1.450
D	0.270	0.370
E	0.450	0.750
F	0.270	0.330
G	0.650	BSC
J	0.090	0.170
K	0.500	REF
P	0.325	BSC
R1	0.100	0.200
R2	0.100	0.200
S	22.000	BSC
S1	11.000	BSC
V	22.000	BSC
V1	11.000	BSC
Y	0.250	REF
Z	1.000	REF
AA	0.090	0.160
theta	0°	8°
theta 1	3°	7°
theta 2	11°	13°
theta 3	11°	13°

Figure B-3 112-pin LQFP Mechanical Dimensions (case no. 987)

FINAL PAGE OF 126 PAGES

How to Reach Us:

USA/Europe/Locations not listed:
Freescale Semiconductor Literature Distribution
P.O. Box 5405, Denver, Colorado 80217
1-800-521-6274 or 480-768-2130

Japan:
Freescale Semiconductor Japan Ltd.
SPS, Technical Information Center
3-20-1, Minami-Azabu
Minato-ku
Tokyo 106-8573, Japan
81-3-3440-3569

Asia/Pacific:
Freescale Semiconductor H.K. Ltd.
2 Dai King Street
Tai Po Industrial Estate
Tai Po, N.T. Hong Kong
852-26668334

Learn More:
For more information about Freescale
Semiconductor products, please visit
<http://www.freescale.com>

Information in this document is provided solely to enable system and software implementers to use Freescale Semiconductor products. There are no express or implied copyright licenses granted hereunder to design or fabricate any integrated circuits or integrated circuits based on the information in this document.

Freescale Semiconductor reserves the right to make changes without further notice to any products herein. Freescale Semiconductor makes no warranty, representation or guarantee regarding the suitability of its products for any particular purpose, nor does Freescale Semiconductor assume any liability arising out of the application or use of any product or circuit, and specifically disclaims any and all liability, including without limitation consequential or incidental damages. "Typical" parameters which may be provided in Freescale Semiconductor data sheets and/or specifications can and do vary in different applications and actual performance may vary over time. All operating parameters, including "Typicals" must be validated for each customer application by customer's technical experts. Freescale Semiconductor does not convey any license under its patent rights nor the rights of others. Freescale Semiconductor products are not designed, intended, or authorized for use as components in systems intended for surgical implant into the body, or other applications intended to support or sustain life, or for any other application in which the failure of the Freescale Semiconductor product could create a situation where personal injury or death may occur. Should Buyer purchase or use Freescale Semiconductor products for any such unintended or unauthorized application, Buyer shall indemnify and hold Freescale Semiconductor and its officers, employees, subsidiaries, affiliates, and distributors harmless against all claims, costs, damages, and expenses, and reasonable attorney fees arising out of, directly or indirectly, any claim of personal injury or death associated with such unintended or unauthorized use, even if such claim alleges that Freescale Semiconductor was negligent regarding the design or manufacture of the part.

Freescale™ and the Freescale logo are trademarks of Freescale Semiconductor, Inc. All other product or service names are the property of their respective owners.
© Freescale Semiconductor, Inc. 2004.