

AND8038

Implementing the NCP1200 in a 10 W AC/DC Wall Adapter

Prepared by: Christophe Basso
ON Semiconductor



ON Semiconductor™

<http://onsemi.com>

APPLICATION NOTE

INTRODUCTION

The NCP1200 implements a standard current mode architecture where the switch-off time is dictated by the peak primary current setpoint. By combining fixed frequency and skip cycle operation in a single integrated circuit, ON Semiconductor NCP1200 represents an excellent solution where cost and ease of implementation are premium: low-cost AC/DC adapters, auxiliary supplies, etc. Furthermore, the device does not require any auxiliary winding to operate and thus offers a real breakthrough alternative to UC384X based supplies. This application note details how to build an efficient and

rugged 10 W adapter. This adapter is designed to operate from a universal mains (90–260 VAC) while providing a good standby power at no load.

The Electrical Schematic

Driving an external MOSFET, the NCP1200P60, only requires a sense element and a V_{CC} capacitor. Working together with an internal high-voltage current source, this V_{CC} capacitor provides the NCP1200 with an average DC level of 11 V typically while it also controls the short-circuit time out. All these parameters are detailed in the application note AND8023 available to download at www.onsemi.com. The electrical schematic appears in Figure 1:

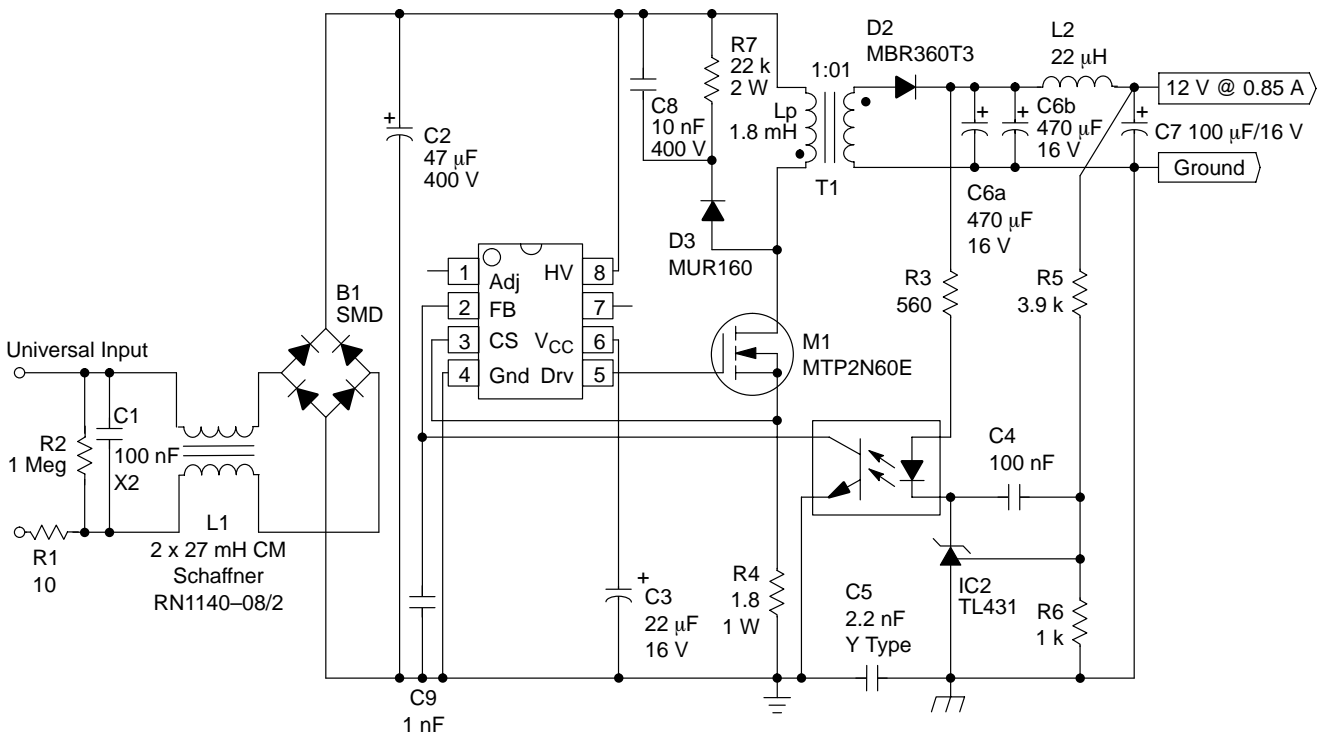

Figure 1. A 10 W AC/DC adapter built with the NCP1200

As stated in AND8023, the V_{cc} capacitor needs to be evaluated taking into account the startup sequence (actually seen as a transient short-circuit by the controller). An internal error flag is raised within the NCP1200 when an output overload occurs. If this error flag is still asserted when the V_{cc} capacitor reaches UVLO_{Low} (around 10 V typical), then the IC goes into the latch-off phase: the output drive is locked and the internal consumption falls down to 350 μA typical. When another V_{cc} breakpoint is reached (around 6.0 V), then the internal current source turns on again and the IC tries to restart. If the error is still present, the

protection activates again. If the short-circuit has gone, the IC resumes its operation and delivers its normal level. To check the correct value of the calculated V_{cc} capacitor, you need to monitor both output voltage and V_{cc} level on an oscilloscope. A shot as proposed by Figure 2 confirms the validity of a 22 μF choice. We can see that the internal error flag goes high first but as soon as V_{out} reaches its target level, the flag goes back to zero, confirming the normal controller behavior at the UVLO_{Low} checkpoint. This experiment should be carried in the worse case conditions, e.g. low mains and maximum output load.

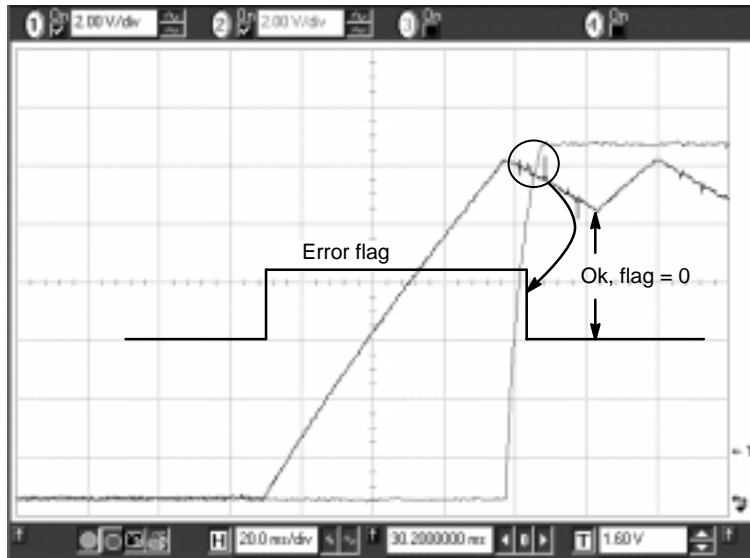

Figure 2. The startup sequence shows a V_{out} establishment before UVLO_{Low} is reached

Feedback Loop

In this application, a precise output voltage is obtained through the use of a TL431. Since we target a 12 V output, you calculate the upper and lower voltage sense elements by applying the following formula:

$$V_{out} = \left(\frac{R_{upper}}{R_{lower}} + 1 \right) \cdot V_{ref}$$

Depending on the TL431 type, V_{ref} can be 2.5 V or 1.25 V. With a 2.5 V reference, R_{upper} (R5) = 3.9 kΩ and R_{lower}

(R6) = 1.0 kΩ. This network ensures a bridge current flow of 2.0 mA which is good for the noise immunity. As any closed loop systems, a compensation network needs to be tailored to stabilize the loop. In this aspect, the NCP1200 average SPICE model will save you a tremendous amount of time. The simulation template appears in Figure 3 on the following page, showing how to wire the NCP1200 average model with INTUSOFT’s IsSpice4.

AND8038

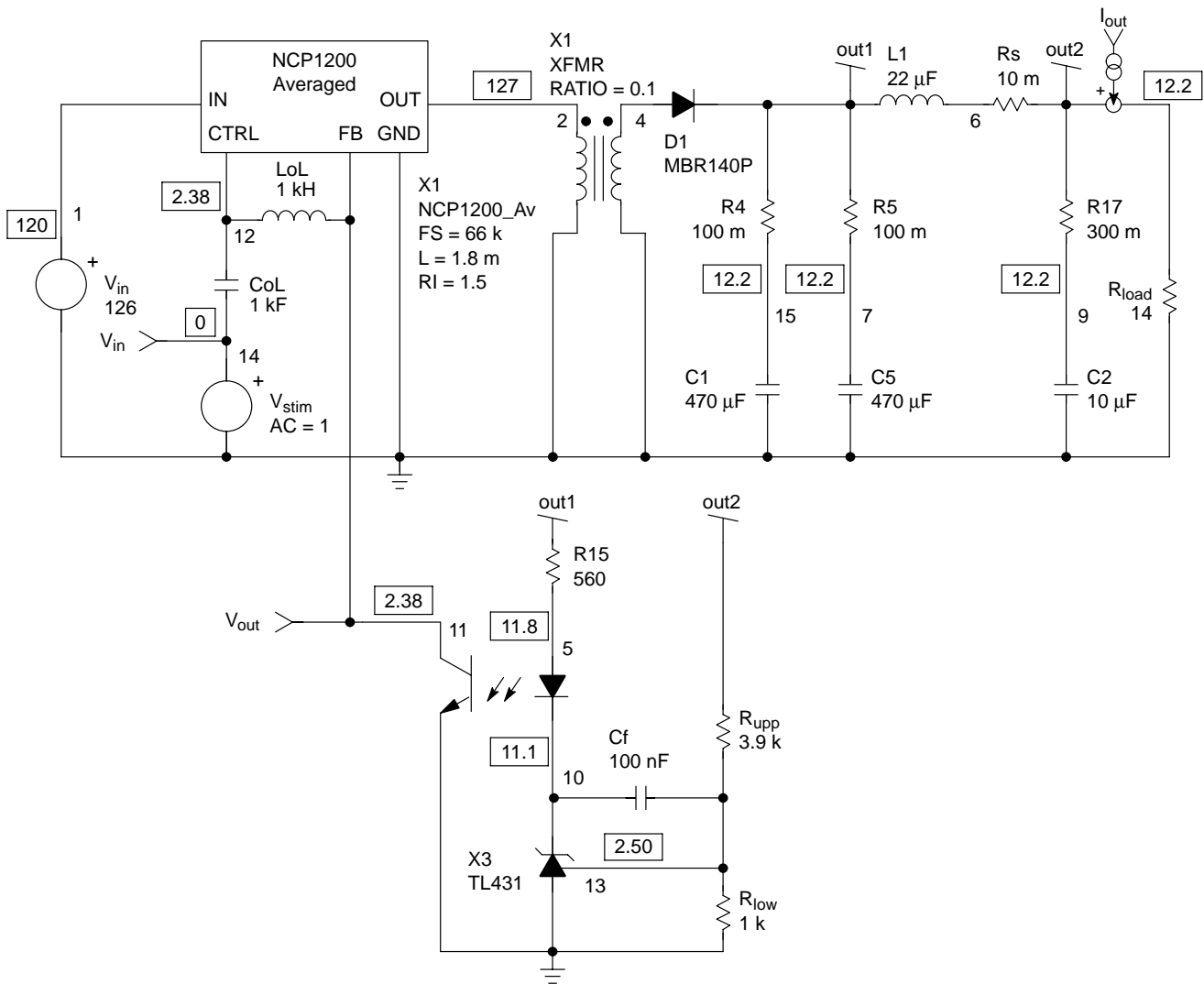

Figure 3. The average model of the NCP1200 when used in AC analysis

The loop is kept opened in AC thanks to LoL which exhibits a fairly high value. However, during its bias point calculation, SPICE opens all capacitors and shorts all inductors. Therefore, LoL closes the loop in DC but blocks

the AC stimuli to allow Bode plot generation. Figure 4 portrays the simulated results with a 100 nF feedback capacitor, while Figure 5 offers the true measurement curves.

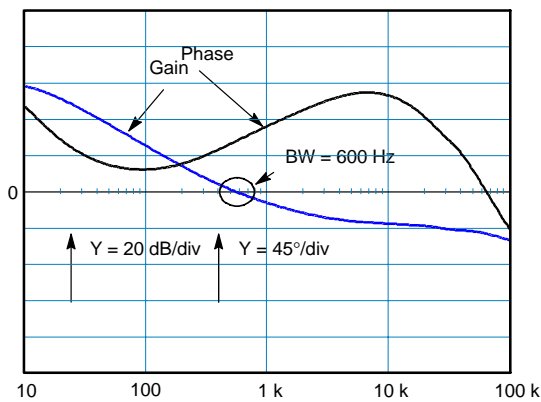

Figure 4. Bode plot obtained using SPICE...

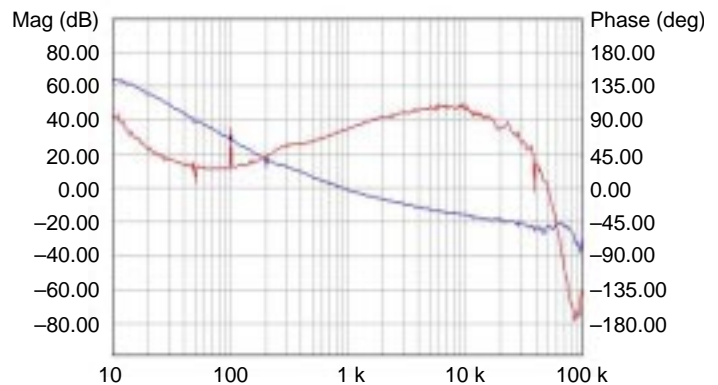

Figure 5. ...confirmed by a network analyzer measurement

As you can see, curves are in good agreement, despite the small DC gain error which predicts a slightly lower bandwidth in the case of SPICE. In both cases, the phase and gain margins confirm the good stability of the design, but also the validity of the SPICE model (based on Ben-Gurion University GSIM approach). The NCP1200 FB pin being a high impedance path, a 1.0 nF placed between this pin and ground will prevent any noise picking during operation.

Transient Results

Using the NCP1200 design aid spreadsheet lead us to a transformer offering the following specs: Lprim = 1.8 mH, Np:Ns = 1:0.1, RM8 or E25 core. For ease of implementation, this transformer will be available from Coilcraft, as referenced in the bill of material. The maximum peak current has been fixed to 600 mA. This value essentially defines the air gap requirement in the transformer but also the final potential transformer mechanical noise generated in standby. As explained, the NCP1200 skips

switching cycles in standby operation. By default, skip cycle takes place at 1/3rd of the maximum peak current: 200 mA in our case. Because skip cycle frequency will naturally enter into the audible range, it is important that the skip current value does not engender noise. Fortunately, if that would be the case, you could still wire a resistor bridge on pin 4 to fix a DC point different than the default one (1.4 V). As a result, you can force skip operation to happen at less than 1/3rd of the maximum peak current. However, keep in mind that the highest peak currents in skip mode offer the best standby power. This is because of the switching cycles population within the bursts: less cycles mean less switching losses and better efficiency at no load.

A quick method to assess the RMS current in the MOSFET consists in simulating the whole AC adapter with SPICE. This has already been presented in AND8029 and the schematic will not be reproduced here. The simulated results are given below through Figure 6 and Figure 7 while the supply is delivering 10 W:

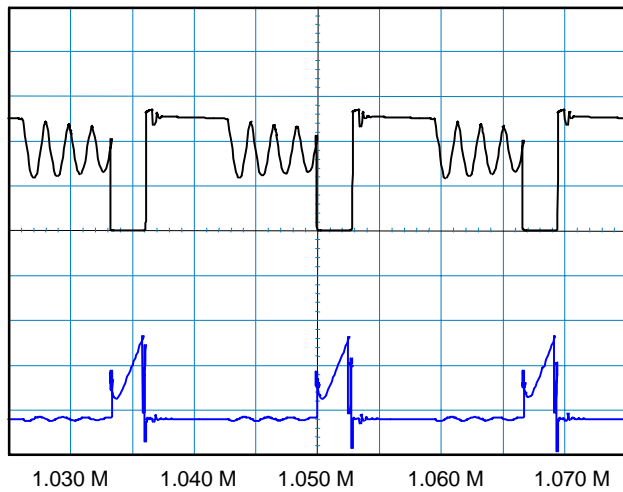

Figure 6. Transient results obtained with IsSpice4...

Worse case conditions (low mains, maximum output current) gives an RMS drain current of 230 mA. Associated with a 6.5 Ω Rds(ON) @ Tj = 100°C, the conduction losses grow up to 340 mW. Using a TO220 package for the MOSFET, offers the ability to dissipate a given amount of

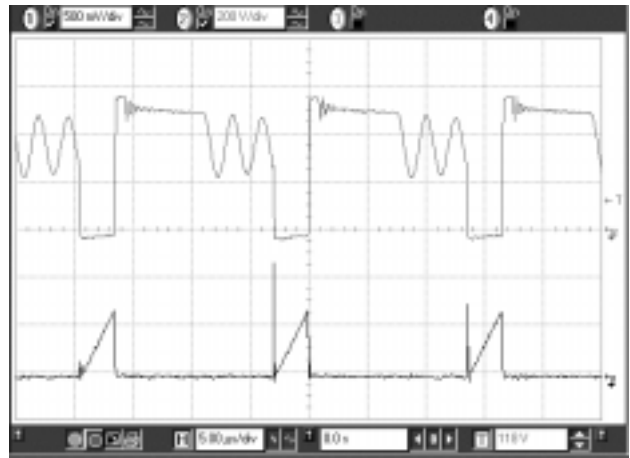

Figure 7. Compared to true measurements

power in free-air conditions (without a heatsink) of:

$$P_{max} = \frac{T_j - T_{amb}}{R_{\theta j - a}} = 1.3 \text{ W.}$$
 Further switching losses measurements confirm the ability to use this MOSFET without any heatsink up to an ambient of 80°C.

AND8038

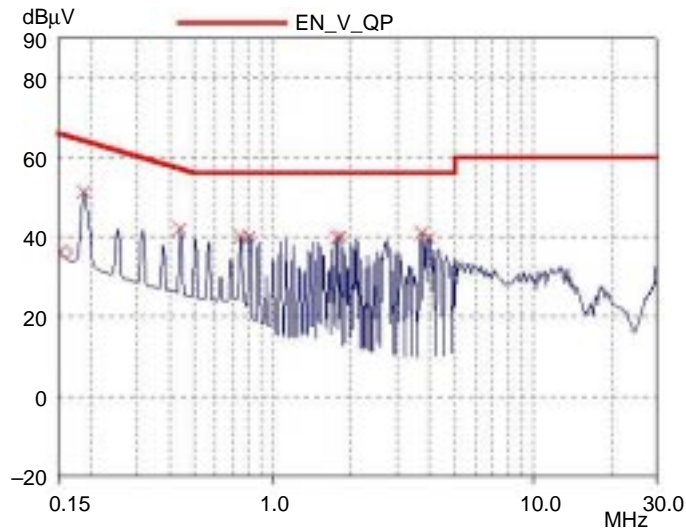

Figure 8. The final composite QP plot carried over one line while the other is loaded (230 VAC, $P_{out} = 10\text{ W}$)

Conducting EMI Filtering

The 10 W NCP1200 demo board is equipped with a front stage filter who lets you pass the CISPR22 EMI tests in both quasi-peak and average detector methods. The method we used for calculating the filter is described in AND8032 “Conducted EMI Filter Design for the NCP1200”. The front stage is made of a single common mode (CM) choke whose wiring method gives enough leakage inductance for differential mode (DM) filtering. Figure 8 plots the final CM+DM noise component confirming the test passing.

Final Performance

We have carried some power tests on the 10 W adapters and the below numbers will confirm the pertinence of choosing ON Semiconductor’s NCP1200 for your next designs:

V_{inDC}	$P_{out}(W)$	$P_{in}(W)$	$\eta(\%)$
126	0	0.245	–
126	10.5	12.6	83.3
356	0	0.462	
356	10.5	13.17	79.7

The standby power can be further reduced by implementing one of the method proposed in AND8023 either through an additional diode or an auxiliary winding.

Thanks to its inherent protection circuitry, NCP1200 protects the power supply in presence of a permanent output short circuit. When shorted, the average output current was less than 500 mA.

AND8038

10 W Demoboard, Bill of Material

R1	10 Ω , 1 W through holes
R2a R2b	2 times 560 k Ω SMD in series
R3	560 Ω SMD
R4	1.8 Ω , 1 W SMD or 1.8 Ω 1 W through holes
R5	3.9 k Ω SMD
R6	1 k Ω , SMD
R7	22 k Ω , 2 W through holes
L1	Schaffner RN114-08/2
L2	22 μ H, 1 A
M1	MTP2N60E, TO-220 through holes, ON Semiconductor
IC1	SFH615A-2, SMD (optocoupler)
IC2	TL431BC (TO-92), ON Semiconductor
IC3	NCP1200P60, DIP8, ON Semiconductor
C1	100 nF X2/ 250 VAC
C2	47 μ F/400 V, snap-in vertical
C3	22 μ F/16 V, vertical
C4	100 nF, SMD
C5	1.5 nF Y1 type only

C6a	470 μ F/16 V, vertical
C6b	470 μ F/16 V, vertical
C7	100 μ F/16 V, vertical
C8	10 nF/400 V
D1	MUR160, ON Semiconductor
D2	MBRS360T3, ON Semiconductor
B1	Bridge 1 A/600 V, mini DIP
	Transformer available from Coilcraft U.S, ref. : Y8848-A
	Mains connector: Schurter GSF1.1202.31 with fuse

Other Available Documents Related to NCP1200:

AND8023/D, "Implementing the NCP1200 in Low-Cost AC/DC Adapters"

AND8029/D, "Ramp Compensation for the NCP1200"

AND8032/D, "Conducted EMI Filter Design for the NCP1200"

PSpice, IsSpice4 and Micro-Cap *Averaged* and *Transient* models available in ready-to-use templates at www.onsemi.com

NCP1200 Design aid spreadsheet with EBNC1200/D

AND8038

Printed Circuit Board Details

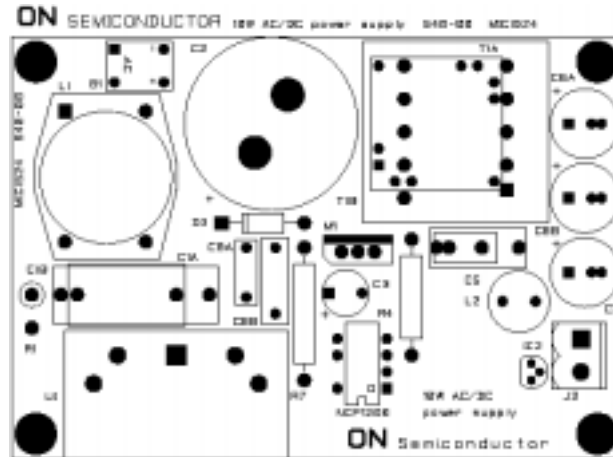

Figure 9. Component Side, Silk Screen, Scale 1

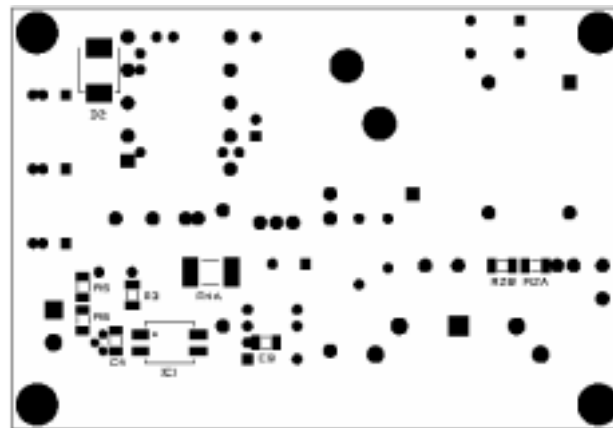

Figure 10. Solder Side, Silk Screen, Scale 1

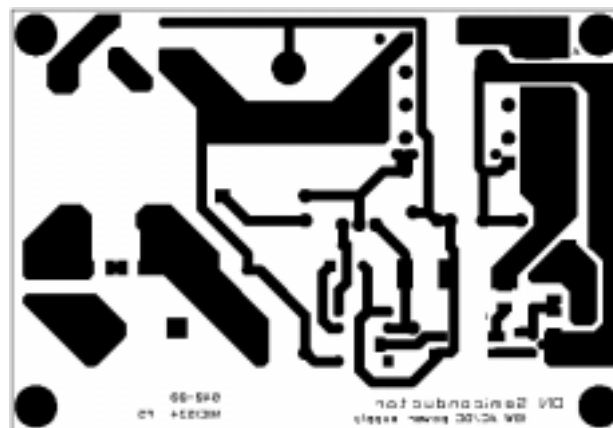

Figure 11. Copper Traces, Scale 1

ON Semiconductor and  are trademarks of Semiconductor Components Industries, LLC (SCILLC). SCILLC reserves the right to make changes without further notice to any products herein. SCILLC makes no warranty, representation or guarantee regarding the suitability of its products for any particular purpose, nor does SCILLC assume any liability arising out of the application or use of any product or circuit, and specifically disclaims any and all liability, including without limitation special, consequential or incidental damages. "Typical" parameters which may be provided in SCILLC data sheets and/or specifications can and do vary in different applications and actual performance may vary over time. All operating parameters, including "Typicals" must be validated for each customer application by customer's technical experts. SCILLC does not convey any license under its patent rights nor the rights of others. SCILLC products are not designed, intended, or authorized for use as components in systems intended for surgical implant into the body, or other applications intended to support or sustain life, or for any other application in which the failure of the SCILLC product could create a situation where personal injury or death may occur. Should Buyer purchase or use SCILLC products for any such unintended or unauthorized application, Buyer shall indemnify and hold SCILLC and its officers, employees, subsidiaries, affiliates, and distributors harmless against all claims, costs, damages, and expenses, and reasonable attorney fees arising out of, directly or indirectly, any claim of personal injury or death associated with such unintended or unauthorized use, even if such claim alleges that SCILLC was negligent regarding the design or manufacture of the part. SCILLC is an Equal Opportunity/Affirmative Action Employer.

PUBLICATION ORDERING INFORMATION

NORTH AMERICA Literature Fulfillment:

Literature Distribution Center for ON Semiconductor
P.O. Box 5163, Denver, Colorado 80217 USA
Phone: 303-675-2175 or 800-344-3860 Toll Free USA/Canada
Fax: 303-675-2176 or 800-344-3867 Toll Free USA/Canada
Email: ONlit@hibbertco.com
Fax Response Line: 303-675-2167 or 800-344-3810 Toll Free USA/Canada

N. American Technical Support: 800-282-9855 Toll Free USA/Canada

EUROPE: LDC for ON Semiconductor – European Support

German Phone: (+1) 303-308-7140 (Mon-Fri 2:30pm to 7:00pm CET)
Email: ONlit-german@hibbertco.com
French Phone: (+1) 303-308-7141 (Mon-Fri 2:00pm to 7:00pm CET)
Email: ONlit-french@hibbertco.com
English Phone: (+1) 303-308-7142 (Mon-Fri 12:00pm to 5:00pm GMT)
Email: ONlit@hibbertco.com

EUROPEAN TOLL-FREE ACCESS*: 00-800-4422-3781

*Available from Germany, France, Italy, UK, Ireland

CENTRAL/SOUTH AMERICA:

Spanish Phone: 303-308-7143 (Mon-Fri 8:00am to 5:00pm MST)
Email: ONlit-spanish@hibbertco.com
Toll-Free from Mexico: Dial 01-800-288-2872 for Access –
then Dial 866-297-9322

ASIA/PACIFIC: LDC for ON Semiconductor – Asia Support

Phone: 1-303-675-2121 (Tue-Fri 9:00am to 1:00pm, Hong Kong Time)
Toll Free from Hong Kong & Singapore:
001-800-4422-3781
Email: ONlit-asia@hibbertco.com

JAPAN: ON Semiconductor, Japan Customer Focus Center
4-32-1 Nishi-Gotanda, Shinagawa-ku, Tokyo, Japan 141-0031
Phone: 81-3-5740-2700
Email: r14525@onsemi.com

ON Semiconductor Website: <http://onsemi.com>

For additional information, please contact your local Sales Representative.