

# SHINDENGEN

## Schottky Rectifiers (SBD)

## SBD Bridges

# D10SBS4

## 40V 10A

### FEATURES

- Thin Single In-Line Package
- SBD Bridge
- Low VF

### APPLICATION

- Switching power supply
- Home Appliances, Office Equipment
- Telecommunication, Factory Automation

### OUTLINE DIMENSIONS

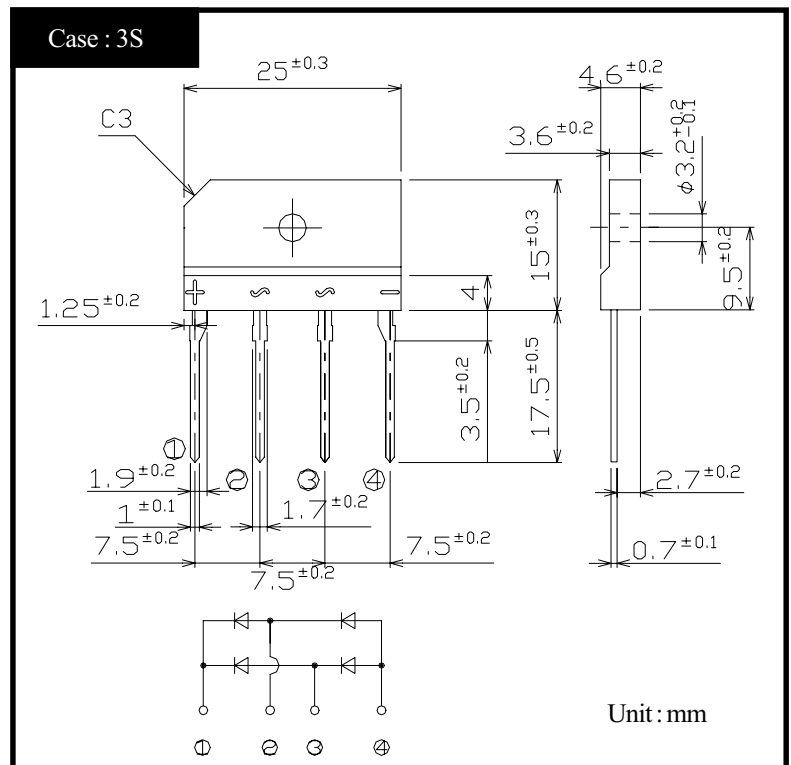

### RATINGS

#### ● Absolute Maximum Ratings (If not specified Tc=25°C)

Item	Symbol	Conditions	Ratings	Unit
Storage Temperature	T <sub>stg</sub>		-55~150	°C
Operating Junction Temperature	T <sub>j</sub>		150	°C
Maximum Reverse Voltage	V <sub>RM</sub>		40	V
Repetitive Peak Surge Reverse Voltage	V <sub>RRSM</sub>	Pulse width 0.5ms, duty 1/40	45	V
Average Rectified Forward Current	I <sub>O</sub>	50Hz sine wave, R-load With heatsink Tc=67°C	10	A
		50Hz sine wave, R-load Without heatsink Ta=25°C	3.4	
Peak Surge Forward Current	I <sub>FSM</sub>	50Hz sine wave, Non-repetitive 1cycle peak value, Tj=25 °C	100	A
Repetitive Peak Surge Reverse Power	P <sub>RRSM</sub>	Pulse width 10 μ s, Rating of per diode, Tj=25°C	330	W
Dielectric Strength	V <sub>dis</sub>	Terminals to case, AC 1 minute	2	kV
Mounting Torque	TOR	( Recommended torque: 0.5N·m)	0.8	N·m

#### ● Electrical Characteristics (If not specified Tc=25°C)

Item	Symbol	Conditions	Ratings	Unit
Forward Voltage	V <sub>F</sub>	I <sub>F</sub> =5A, Pulse measurement, Rating of per diode	Max.0.55	V
Reverse Current	I <sub>R</sub>	V <sub>R</sub> =V <sub>RM</sub> , Pulse measurement, Rating of per diode	Max.3.5	mA
Junction Capacitance	C <sub>j</sub>	f=1MHz, V <sub>R</sub> =10V, Rating of per arm	TYP 180	pF
Thermal Resistance	θ <sub>jc</sub>	junction to case With heatsink	Max.5.5	°C/W
	θ <sub>jl</sub>	junction to lead Without heatsink	Max.6	
	θ <sub>ja</sub>	junction to ambient Without heatsink	Max.30	

# D10SBS4

## Forward Voltage

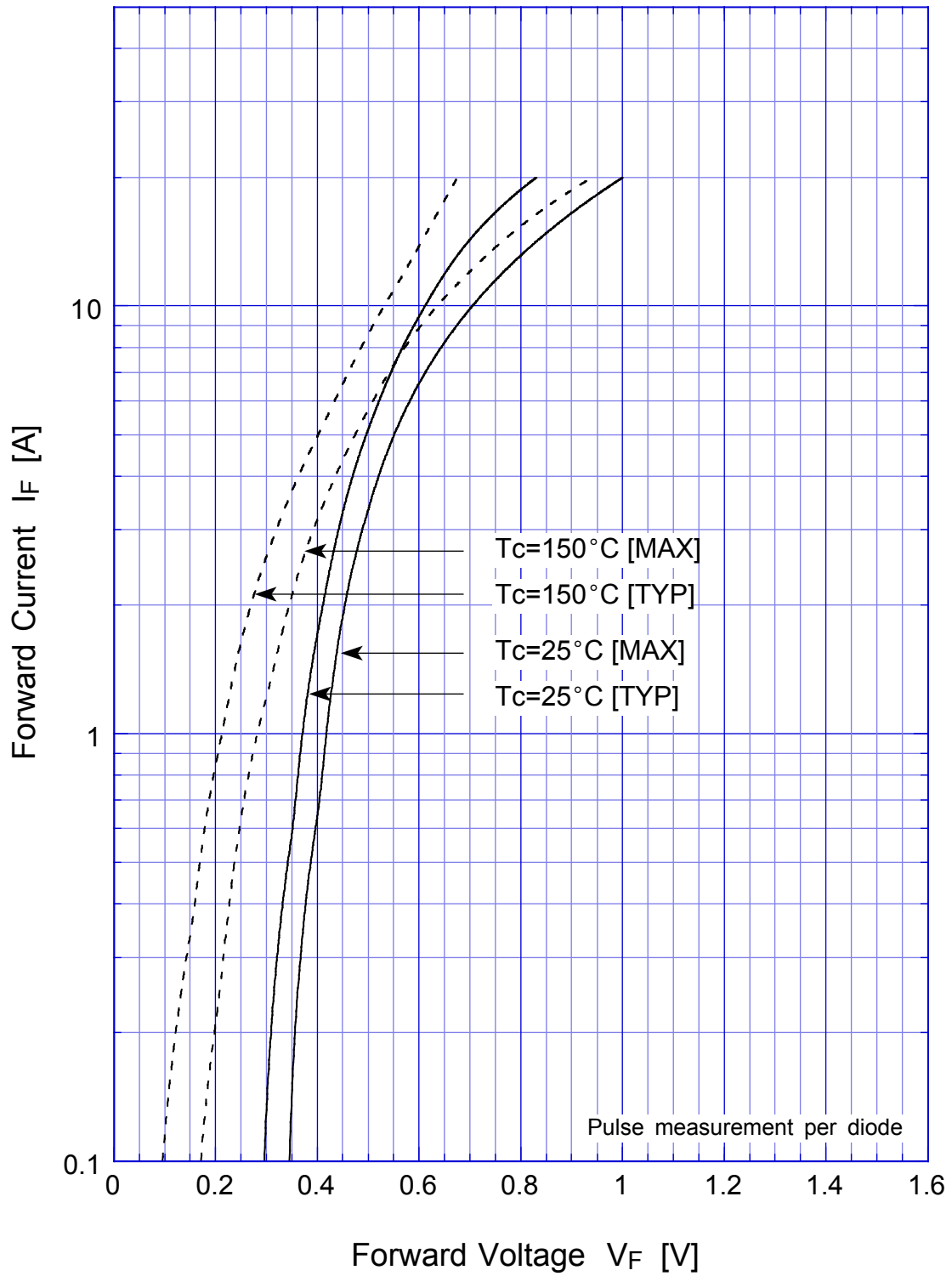

## D10SBS4 Junction Capacitance

---

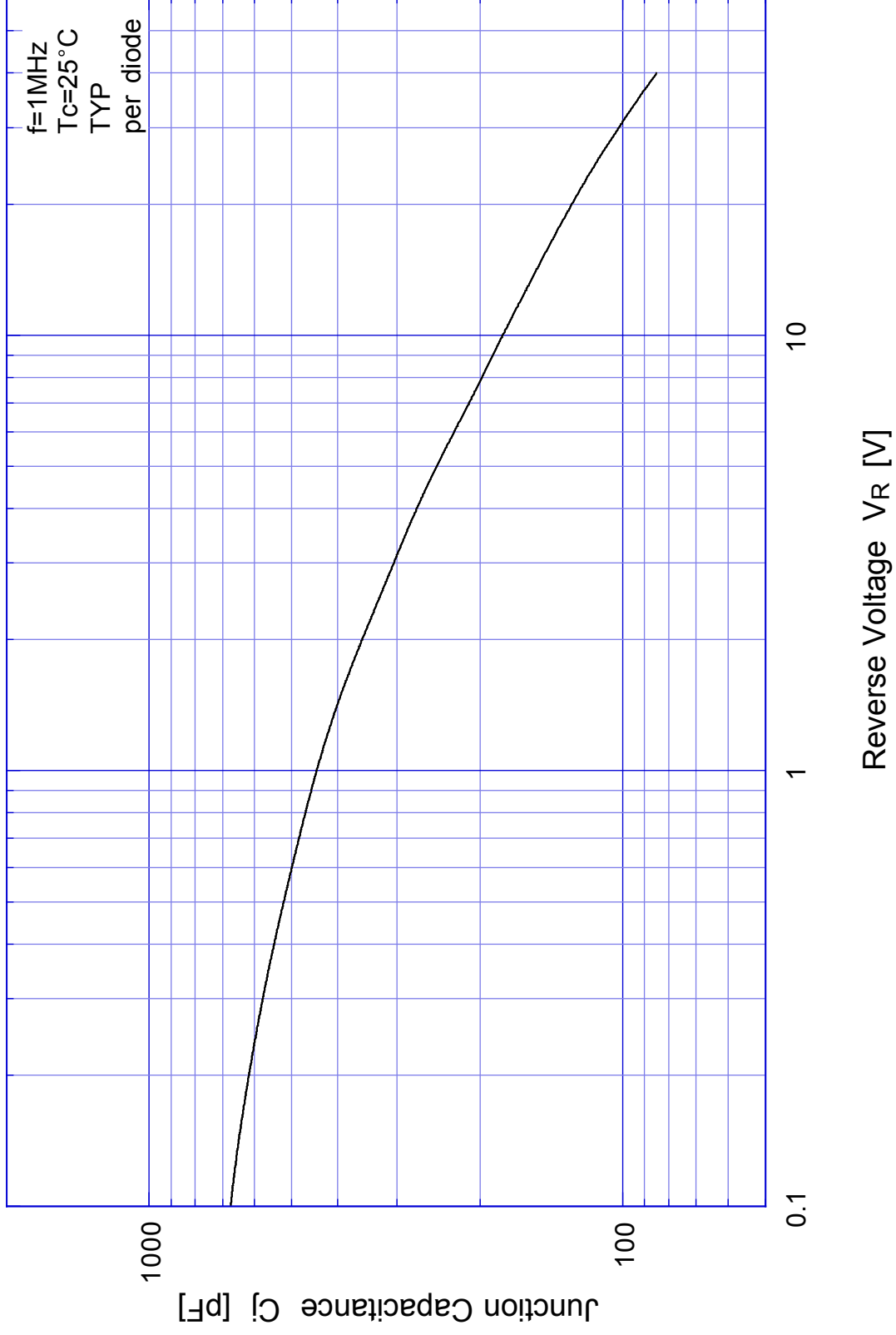

# D10SBS4 Reverse Current

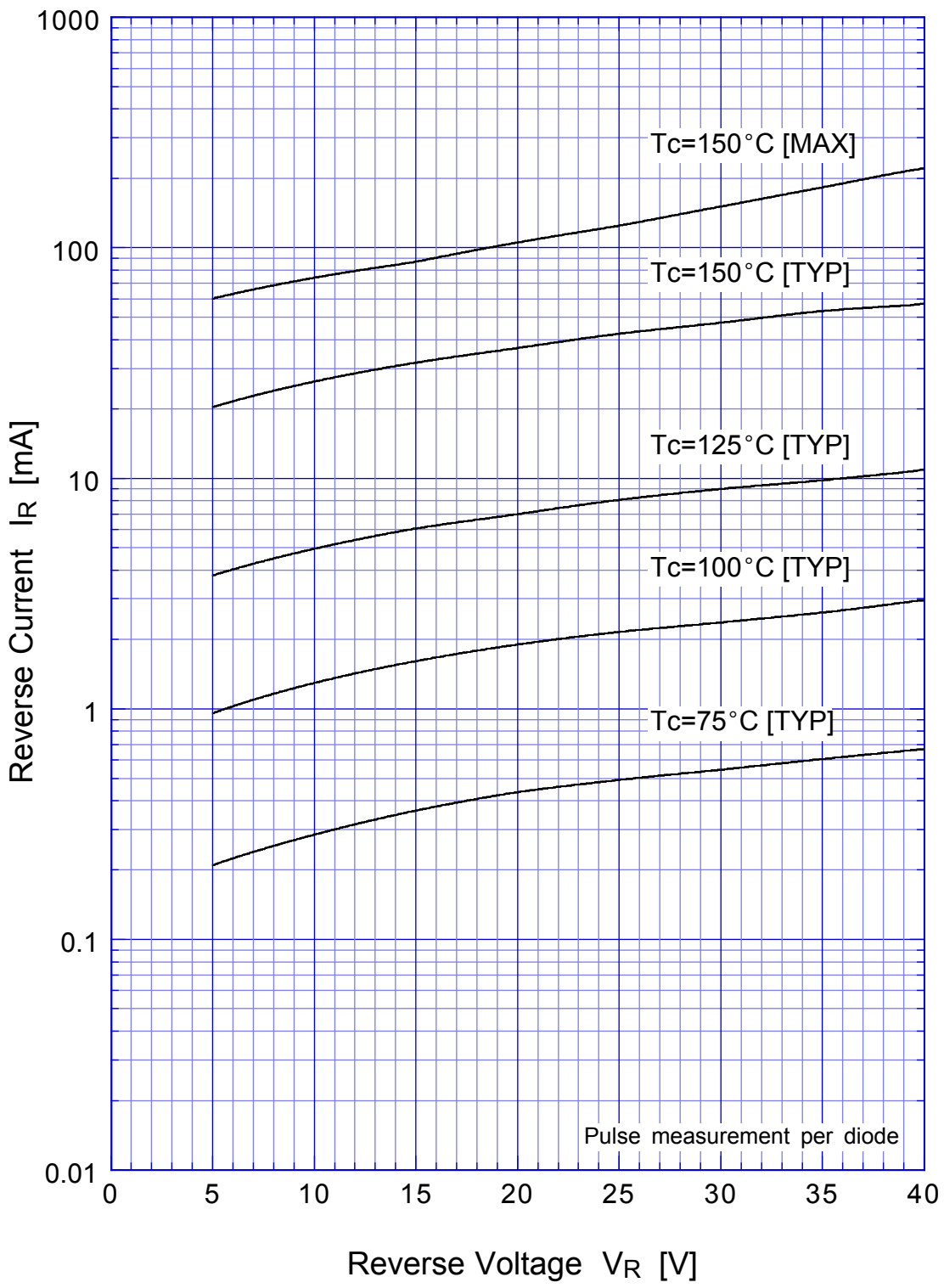

# D10SBS4 Reverse Power Dissipation

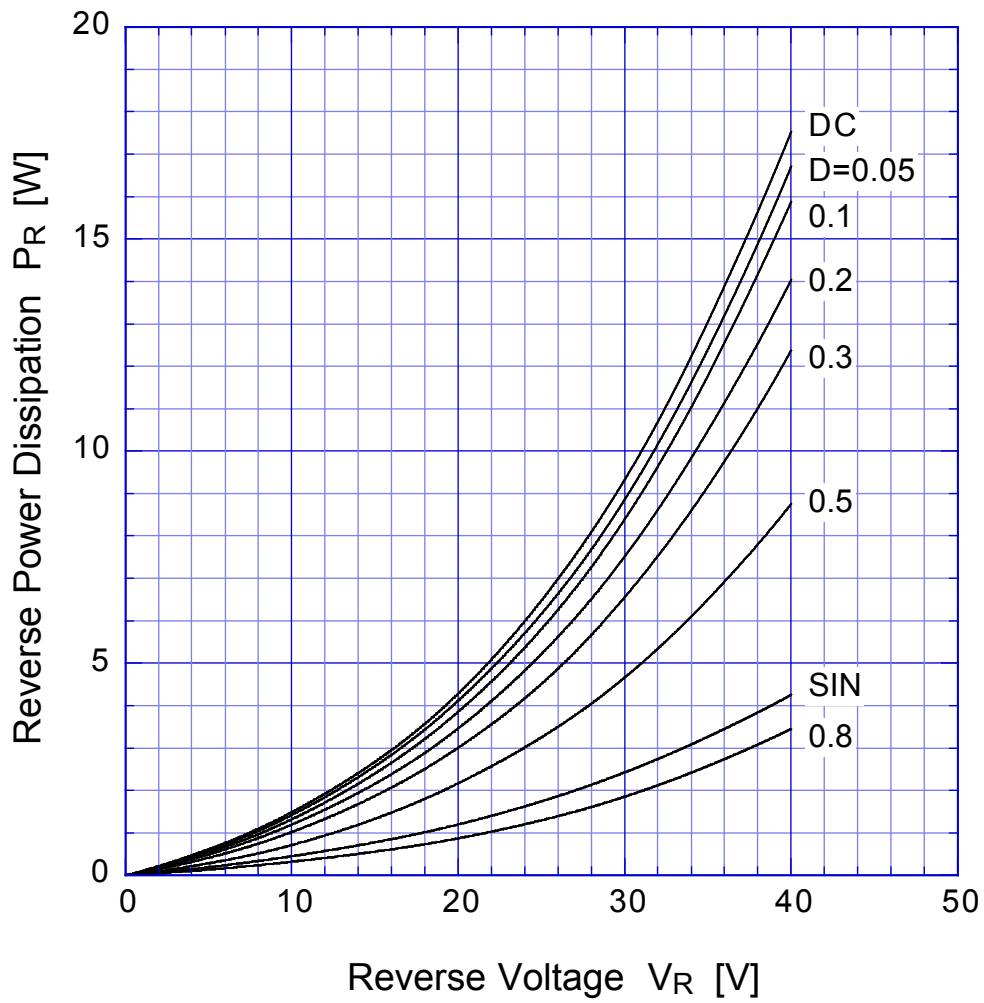

$T_j = 150^\circ\text{C}$

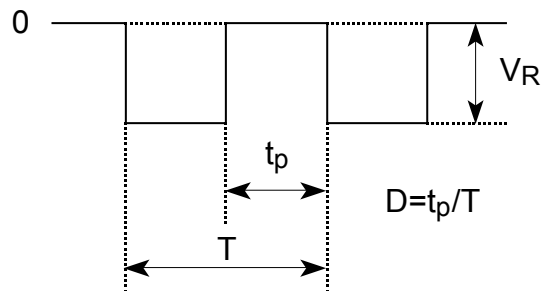

# D10SBS4 Forward Power Dissipation

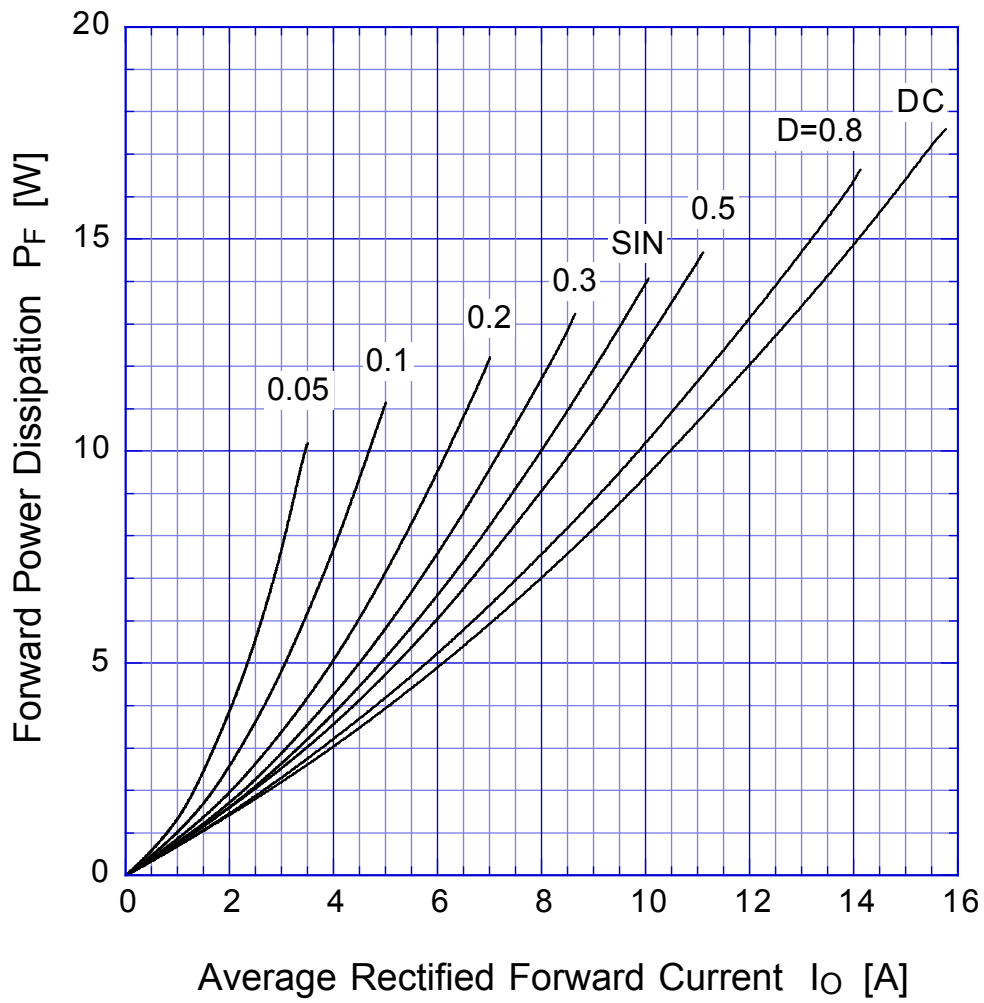

$T_j = 150^\circ\text{C}$

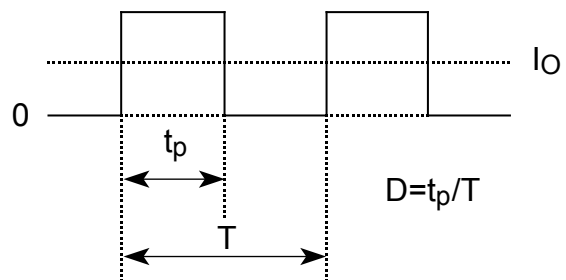

# D10SBS4

# Derating Curve

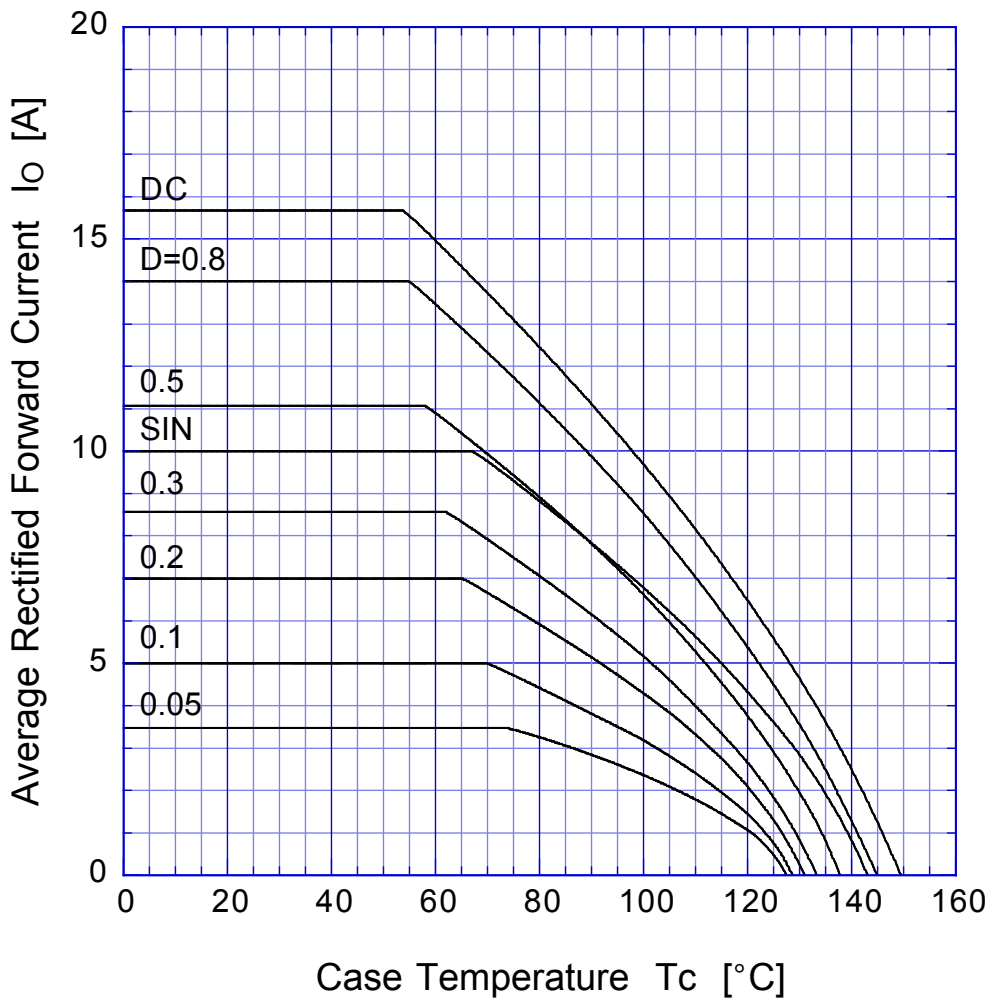

$V_R = 20V$

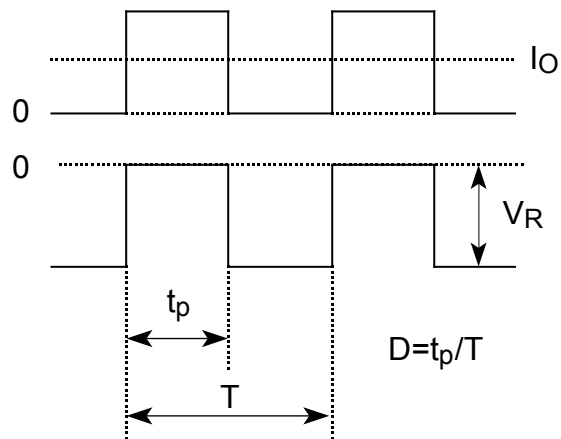

# D10SBS4

# Derating Curve

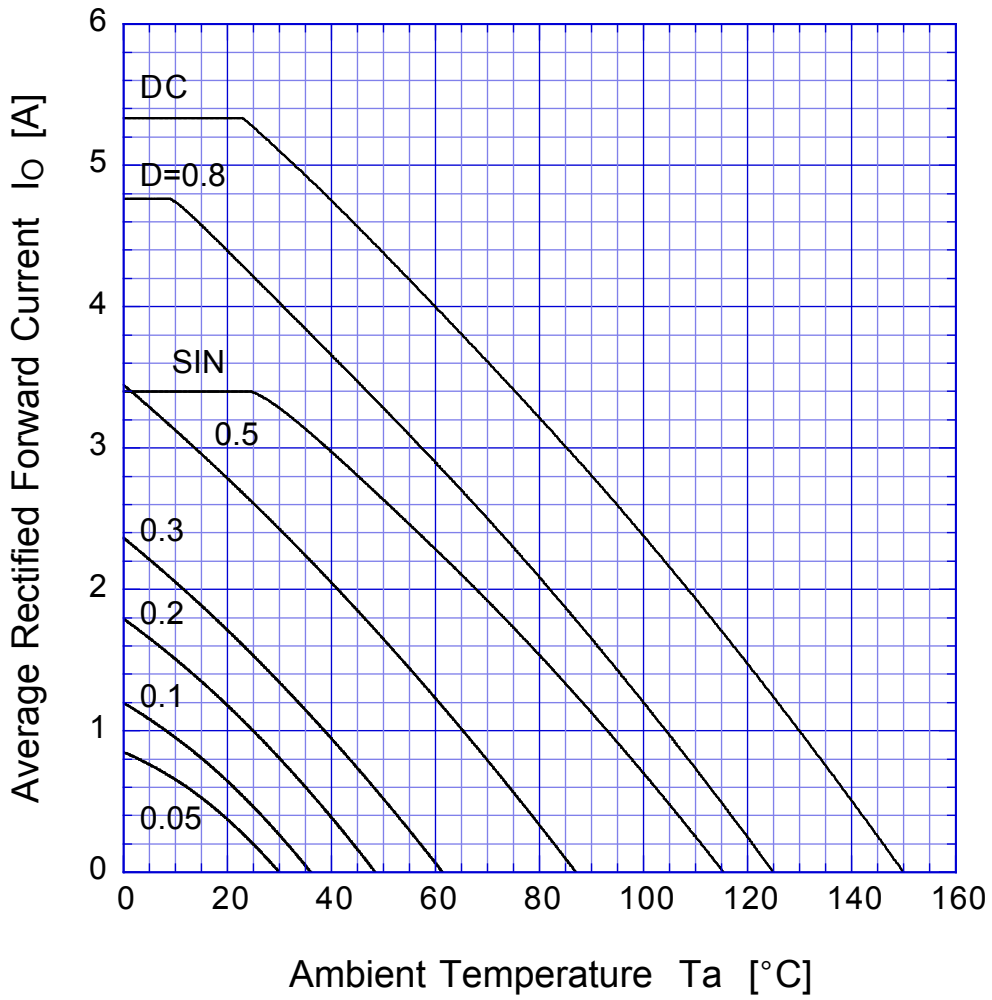

$V_R = 20V$

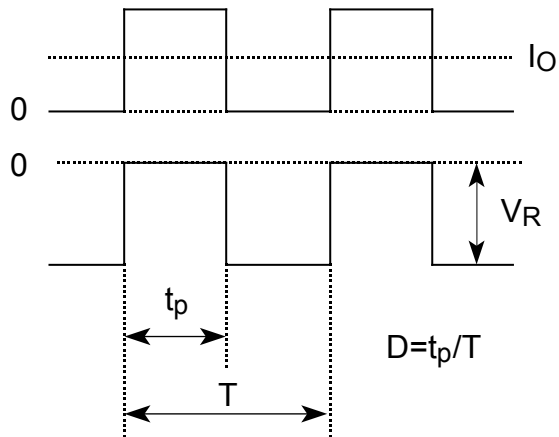



# D10SBS4 Peak Surge Forward Capability

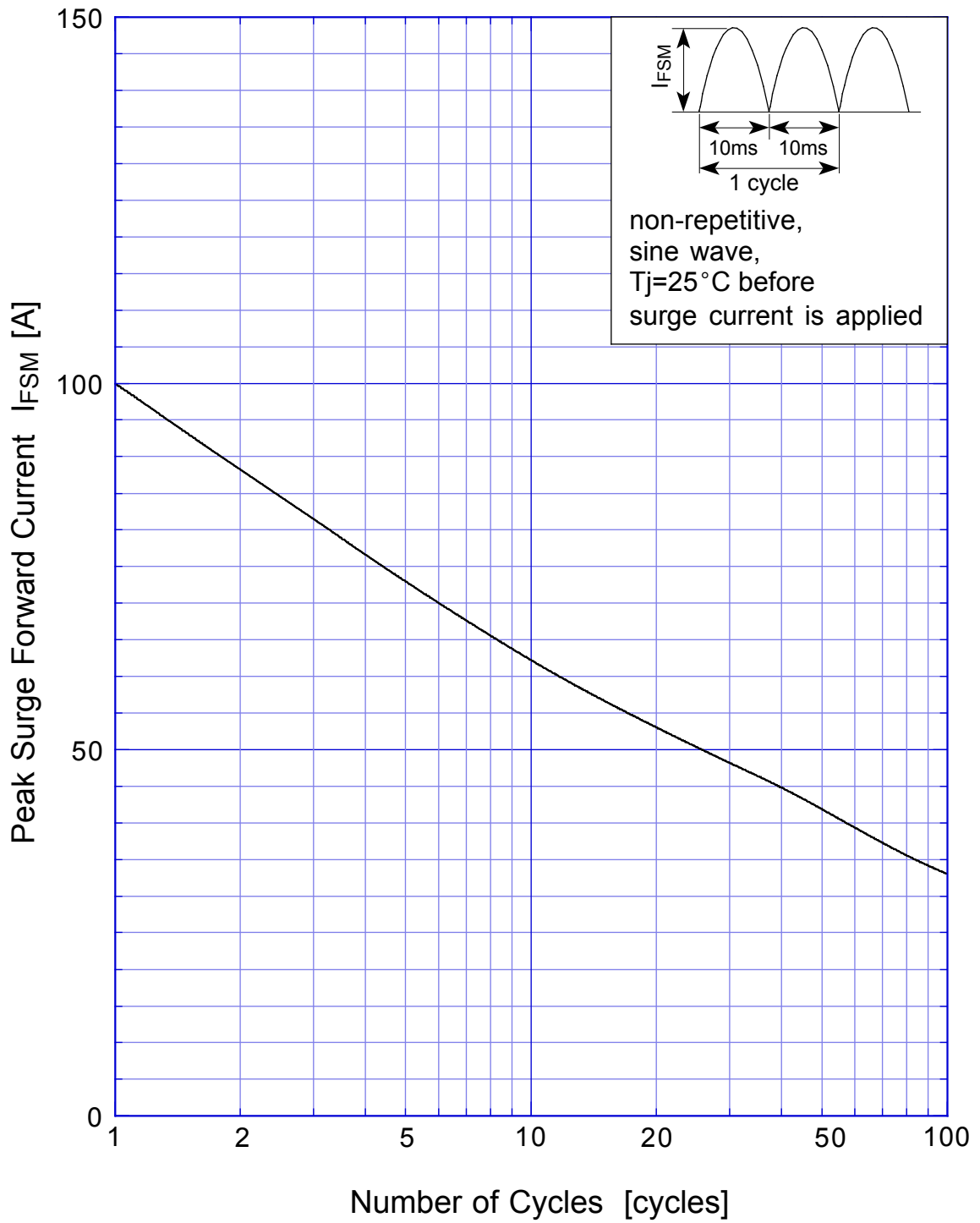

# SBD Repetitive Surge Reverse Power Derating Curve

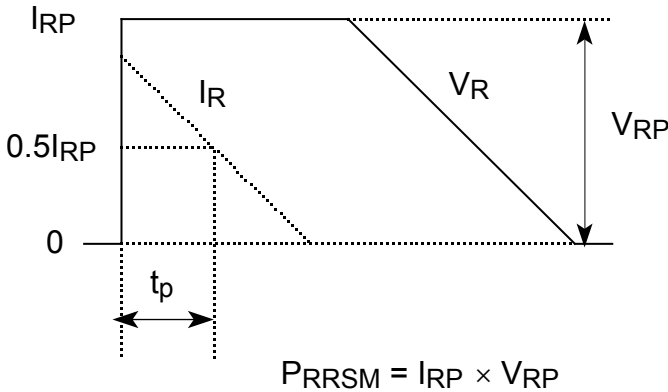
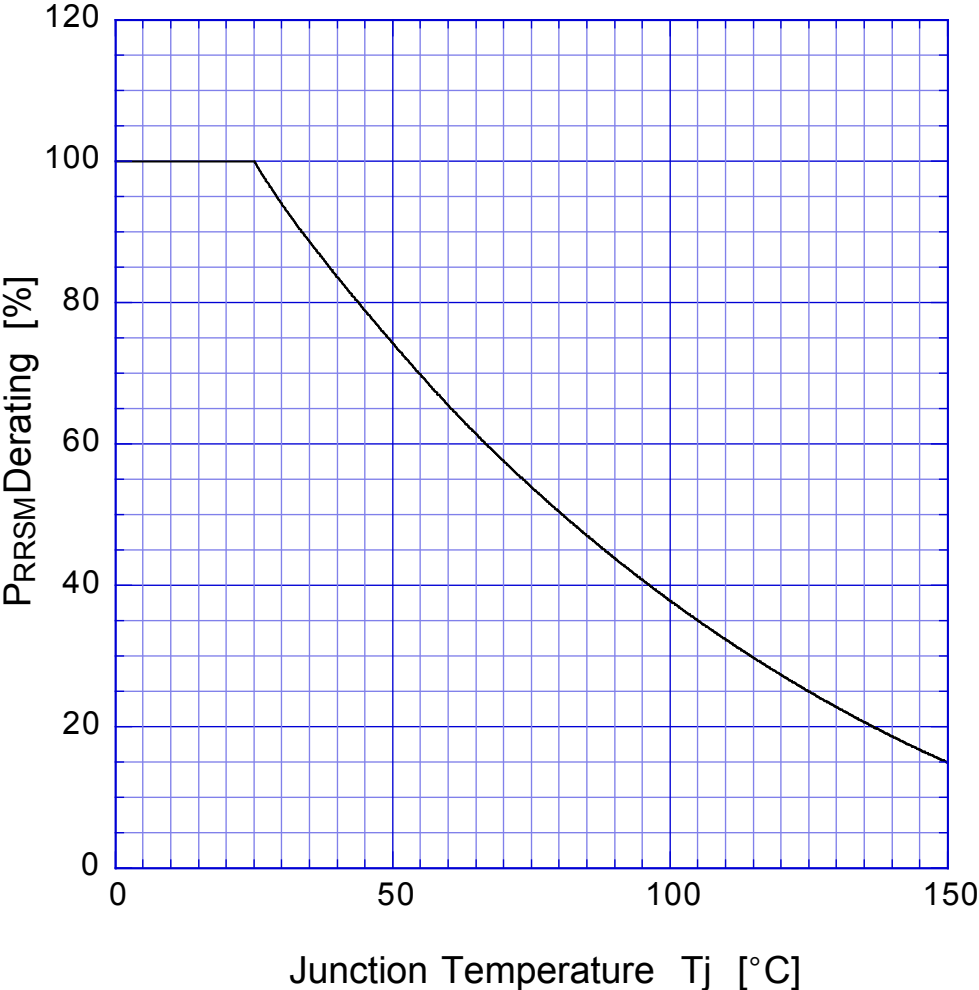

# SBD

## Repetitive Surge Reverse Power Capability

