

LOW INSERTION LOSS LINE MATCHING TRANSFORMER

P3303

Features

- * Lead-free (Pb-free)
- * RoHS compliant
- * Low Insertion Loss, <1dB
- * 12.6mm (0.5") Seated Height
- * Industry Standard Pinout
- * IEC 60950 and UL 60950 Certified
- * UL Recognized Component
- * Environmentally tested to IEC 68
- * CERT reliability tested
- * Excellent Frequency Response
- * Simple Matching
- * High Thermal Stability

Applications

- * Voice
- * V.22bis Modems
- * SLIC Interfaces
- * PABX
- * Instrumentation

DESCRIPTION

P3303 is intended for voice and low speed data applications where good distortion at moderate power levels is required with low insertion loss.

P3303 uses patented design and construction methods to achieve excellent signal performance and safety isolation to international standards, making it the component of choice for low loss voice and data applications throughout the world. P3303 is certified to IEC 60950 and UL 60950. P3303 is a UL Recognized Component, and is supported by an IEC CB Test Certificate. The part is completely lead-free, compliant with RoHS Directive 2002/95/EC, and suitable for lead-free and conventional processing.

P3303 has been subjected to relevant environmental testing according to IEC 68 and Combined Environmental Reliability Testing (CERT) beyond normal operational levels and passed all tests, remaining fully functional.

P3303 has exceptionally flat frequency response from 100Hz to 10kHz, a 3dB bandwidth of typically 90kHz and requires only the very simplest of matching to achieve good return loss and transhybrid loss across the voiceband, with low levels of signal distortion at signal frequencies as low as 200Hz.

P3303 has very low leakage inductance and winding resistances and is designed for use with AMD QSLAC devices.

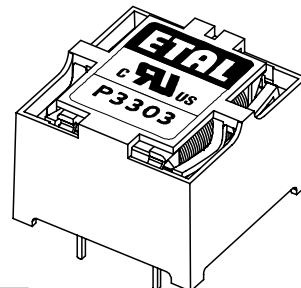

Patented



SPECIFICATIONS

Electrical

At T = 25°C and as test circuit Fig. 2 unless otherwise stated.

Parameter	Conditions	Min	Typ	Max	Units
Insertion Loss	f = 2kHz	-	0.9	-	dB
Frequency Response	LF -3dB cutoff	-	30	-	Hz
	HF -3dB cutoff	-	90	-	kHz
	200Hz – 4kHz	-	-	±0.1	dB
Return Loss	200Hz – 4kHz	-	20	-	dB
Transhybrid Loss	200Hz – 4kHz	-	30	-	dB
Third Harmonic Distortion ^{(1) (3)}	300Hz 0dBm in line	-	-70	-	dBm
	600Hz -10dBm in line	-	-95	-	dBm
Signal Handling ⁽³⁾	300Hz	-	3.5	-	Vrms
	200Hz	-	2.5	-	Vrms
Voltage Isolation ⁽²⁾	50Hz	2.12	-	-	kVrms
	DC	3.0	-	-	kV
Operating Range:	Functional	0	-	+70	°C
	Storage	-40	-	+85	°C

Lumped equivalent circuit parameters as Fig. 1

DC resistance ⁽³⁾	Primary resistance R_{DCP}	34	-	42	Ω
	Secondary resistance R_{DCS}	48	-	58	Ω
Leakage inductance, ΔL		1.7	-	2.8	mH
Shunt inductance, L_p ⁽⁴⁾	10mV 200Hz	4	6	-	H
Shunt loss, R_p ⁽⁴⁾	10mV 200Hz	8	10	-	k Ω

Notes:

1. Third harmonic typically exceeds other harmonics by 10dB.
2. Components are 100% tested at 3.25kVDC.
3. Caution: do not pass DC through windings. Telephone line current must be diverted using semiconductor line hold circuit or choke.
4. At signal levels greater than 100mV, L_p will increase and R_p will decrease slightly but the effect is usually favourable to the return loss characteristic.

Equivalent Circuit

Fig. 1

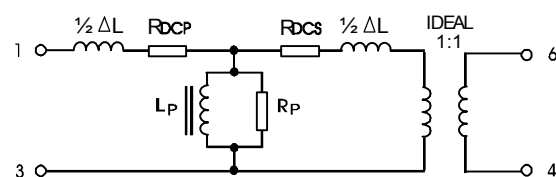

MATCHING RECOMMENDATIONS

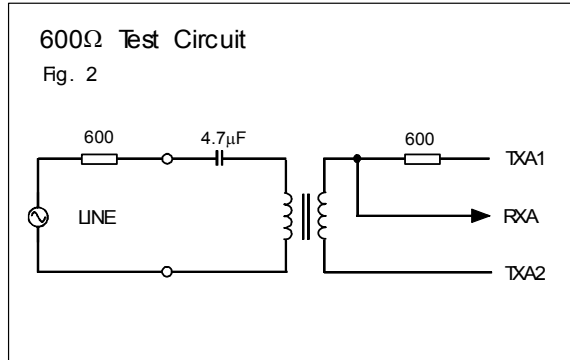

TXA1/TXA2 represent low impedance transmit outputs. RXA represents a high impedance receive input.
Transhybrid loss in specification table assumes TXA1 and TXA2 are balanced outputs.
Other hybrid arrangements are possible.

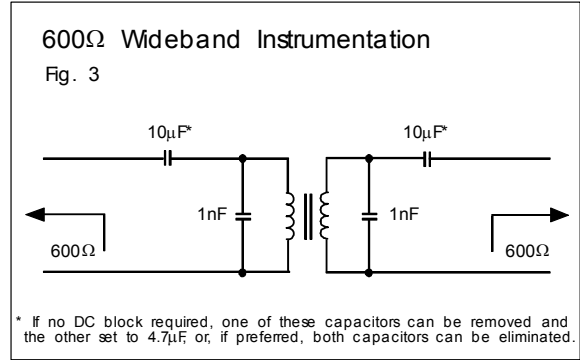

Insertion Loss: 1dB @ 2kHz
Frequency Response : ±0.2dB 100Hz – 20kHz
3dB Bandwidth >100kHz
Return Loss: 16dB 100Hz – 20kHz

CONSTRUCTION

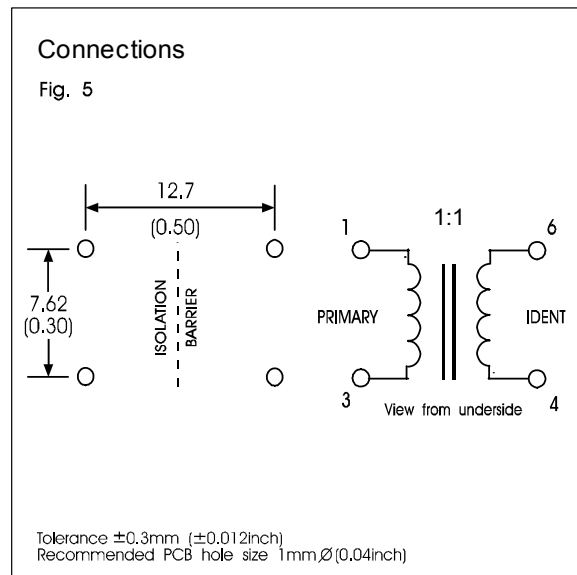
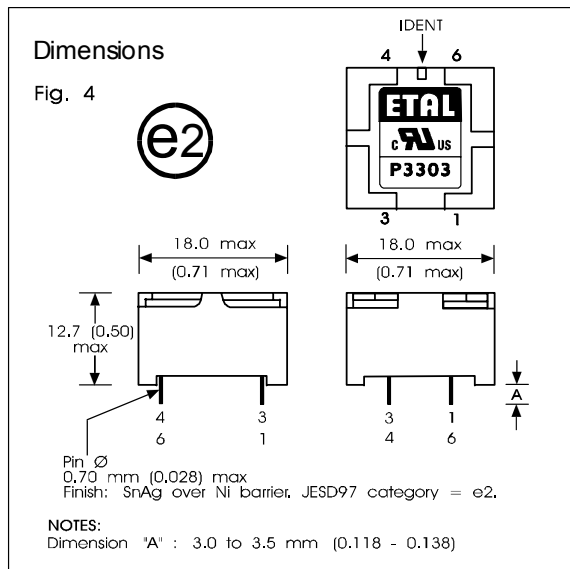

Dimensions shown are in millimetres (inches).
Geometric centres of outline and pin grid coincide within a tolerance circle of 0.6mmØ.
Windings may be used interchangeably as primary or secondary.
Total weight typically 7g.

Patented

ENVIRONMENTAL TESTING

Reliability testing to IEC 68

Tested to clauses of IEC 68 and compliant with all functional and safety requirements following exposure as follows:

Test description	IEC 68 reference	Test details	Result
Robustness of terminations	68-2-21 Test Ua ₁ 68-2-21 Test Ua ₂	Tensile 5N pull Thrust 1N push	No impairment No pin detachment or distortion
Solderability	68-2-20 Test Ta Method 1	Solder bath 235°C 2s	No impairment Finish smooth, bright and even
Resistance to soldering heat	68-2-20 Test Tb Method 1A 68-2-20 Test Tb Method 2	Solder bath 260°C 10s Soldering iron 350°C 5s	
Vibration	68-2-6 Test Fc	Sweep 10-55-10Hz in 1 minute Amplitude 1.5mm pk-pk Duration 2h per axis, 3 axes	No impairment
Shock	68-2-27 Test Ea	Peak acceleration 1000m/s ² Duration of pulse 6ms 3 shocks each direction on 3 axes	No impairment
Cold	68-2-1 Test Ab	-25°C 16h Recovery to ambient 1-2h	No impairment
Dry heat	68-2-2 Test Bb	125°C 16h Recovery to ambient 1-2h	No impairment
Damp heat	68-2-3 Test Ca	40°C 4 days, RH 93% Recovery to ambient 1-2h	No impairment
Change of temperature	68-2-14 Test Na	T _A -25°C T _B +85°C t ₁ 30 min 2 min ≤ t ₂ ≤ 3 min Recovery to ambient 1-2h 5 cycles	No impairment

Combined Environmental Reliability Testing (CERT)

Components step stressed at increasing levels of severity using combined stresses to detect potential weaknesses.

Results are shown for highest levels of stress tested. Compliant with all functional and safety tests following exposure as follows:

Test description	Test details	Duration	Result
Storage Test	Thermal cycling -30°C to +100°C at 11°C/min 6mm pk 2-9Hz at 1 octave/min 20m/s ² 9-200Hz	20 mins per plane	No impairment
Transportation Test	Thermal cycling -65°C to +80°C Random vibration 10-200Hz and 200-2000Hz at 57m/s ² RMS	2 hours per plane	No impairment

SAFETY

Constructed in accordance with IEC 60950-1, EN 60950-1, and UL 60950-1 supplementary insulation, 250Vrms maximum working voltage, flammability class V-0.

There are no special installation requirements (beyond attending to usual PCB track separations) since the integral cover provides supplementary insulation from its external faces to internal core and windings.

CERTIFICATION

Certified under the IEC CB scheme (Certificate DK-8570) to IEC 60950-1-2001, sub-clauses 1.5, 1.5.1, 1.5.2, 1.7.1, 2.9, 2.9.1, 2.9.2, 2.9.3, 2.10, 2.10.1, 2.10.2, 2.10.3, 2.10.3.1, 2.10.3.3, 2.10.4, 2.10.5, 2.10.5.1, 2.10.5.2, 2.10.5.4, 4.7, 4.7.1 (classV-1), 4.7.3, 4.7.3.1, 4.7.3.4, 5.2, 5.2.1, 5.2.2, 6.1.2.1 (Finland, Norway, Sweden national deviations) for a maximum working voltage of 250Vrms, nominal mains supply voltage not exceeding 300Vrms and a maximum operating temperature of 70°C in Pollution Degree 2 environments.

Recognized under the Component Recognition Program of Underwriters Laboratories Inc. to US and Canadian requirements CAN/CSA C22.2 No. 60950-1-03/UL60950-1, First Edition, based on IEC 60950-1, First Edition, maximum working voltage 180Vrms (creepage), 420V peak (clearance), Pollution Degree 2, supplementary insulation.

UL File number E203175.

Additionally, Profec Technologies certifies all transformers as providing voltage isolation of 2.12kVrms, 3kV DC minimum. All shipments are supported by a certificate of conformity to current applicable safety standards.

ABSOLUTE MAXIMUM RATINGS

(Ratings of components independent of circuit).

Short term isolation voltage (1s)	2.12kVrms, 3.0 kVDC
DC current	100µA
Storage temperature	-40°C to +85°C
Lead temperature, 10s	260°C

INTELLECTUAL PROPERTY RIGHTS

ETAL and P3303 are Trade Marks of Profec Technologies Ltd.

The Trade Mark ETAL is registered at the UK Trade Marks Registry.

AMD and QSLAC are trademarks of Advanced Micro Devices, Inc.

Profec Technologies Ltd. is the owner of the design right under the Copyright Designs and Patents Act 1988 and no rights or licences are hereby granted or implied to any third party.

P3303 design and construction are protected by patents and registered design.

British Patent No. 2333646.

USA Patent Nos. 6, 344, 787; 6,690,254

European Patent No. 1082734

China Patent No. ZL 99806739.3

UK Registered Design No. 2077360.

French Registered Design No. 991512.

United States Registered Design 426, 815.

Mexico Registered Design 12143

Other patents and registered designs pending.

© 1998 - 2005 Profec Technologies Ltd.

Reproduction prohibited.



ISO 9001
FM 25326

ETAL Group Oy, Kuormatie 14, FIN-03101, Nummela
Telephone: +358 (0)20 7500 330 Fax: +358 (0)20 7500 333
Website: www.etalgroup.com Email: etalgroup@egruppen.com