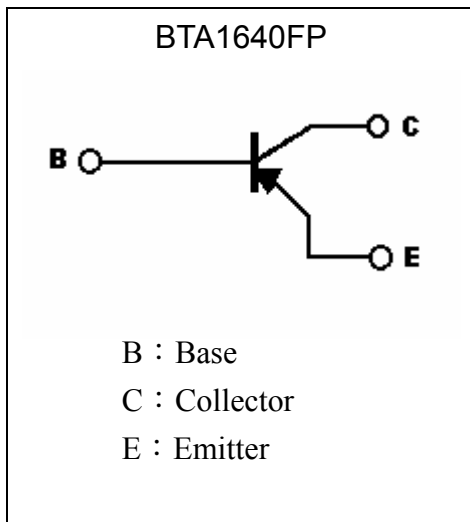
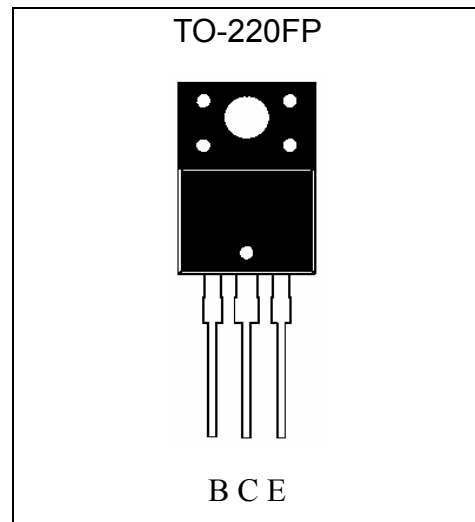

**PNP Epitaxial Planar Power Transistor**

# BTA1640FP

**Features**

- Low collector-emitter saturation voltage,  $V_{CE(sat)} = -0.4V(max) @ I_C = -3A, I_B = -0.1A$
- Excellent current gain linearity
- Pb-free package

**Symbol**

**Outline**

**Absolute Maximum Ratings** ( $T_A = 25^\circ C$ )

Parameter	Symbol	Limits	Unit
Collector-Base Voltage	$V_{CBO}$	-50	V
Collector-Emitter Voltage	$V_{CEO}$	-50	V
Emitter-Base Voltage	$V_{EBO}$	-5	V
Collector Current (DC)	$I_C$	-7	A
Collector Current (Pulse)	$I_{CP}$	-10 (Note 1)	
Power Dissipation @ $T_A = 25^\circ C$	$P_D$	2	W
Power Dissipation @ $T_C = 25^\circ C$	$P_D$	40	
Thermal Resistance, Junction to Ambient	$R_{\theta JA}$	62.5	$^\circ C/W$
Thermal Resistance, Junction to Case	$R_{\theta JC}$	3.125	$^\circ C/W$
Junction Temperature	$T_j$	150	$^\circ C$
Storage Temperature	$T_{stg}$	-55~+150	$^\circ C$

 Note : 1. Single Pulse ,  $P_w \leq 380\mu s$ , Duty  $\leq 2\%$ .



**Characteristics (Ta=25°C)**

Symbol	Min.	Typ.	Max.	Unit	Test Conditions
*BV <sub>CEO</sub>	-50	-	-	V	I <sub>C</sub> =-10mA, I <sub>B</sub> =0
BV <sub>CBO</sub>	-50	-	-	V	I <sub>C</sub> =-1mA, I <sub>E</sub> =0
BV <sub>EBO</sub>	-5	-	-	V	I <sub>E</sub> =-1mA, I <sub>C</sub> =0
I <sub>CEO</sub>	-	-	-50	μA	V <sub>CE</sub> =-30V, I <sub>B</sub> =0
I <sub>CBO</sub>	-	-	-10	μA	V <sub>CB</sub> =-40V, I <sub>B</sub> =0
I <sub>EBO</sub>	-	-	-10	μA	V <sub>EB</sub> =-5V, I <sub>C</sub> =0
*V <sub>CE(sat)</sub>	-	-	-0.4	V	I <sub>C</sub> =-3A, I <sub>B</sub> =-100mA
*V <sub>BE(sat)</sub>	-	-	-1	V	I <sub>C</sub> =-3A, I <sub>B</sub> =-100mA
*h <sub>FE</sub>	250	-	500	-	V <sub>CE</sub> =-2V, I <sub>C</sub> =-200mA

\*Pulse Test : Pulse Width ≤380μs, Duty Cycle≤2%

**Characteristic Curves**

Current Gain vs Collector Current

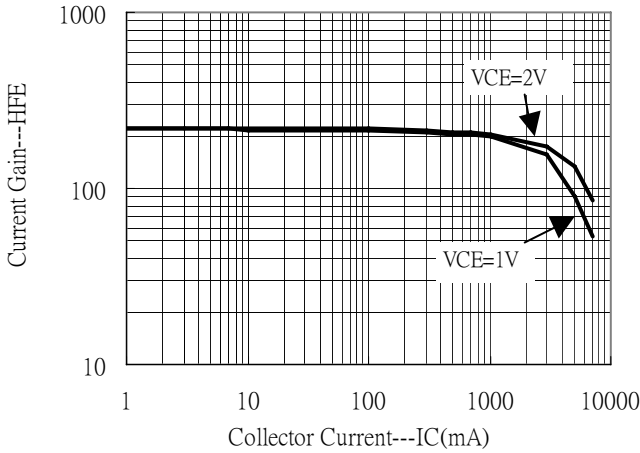

Saturation Voltage vs Collector Current

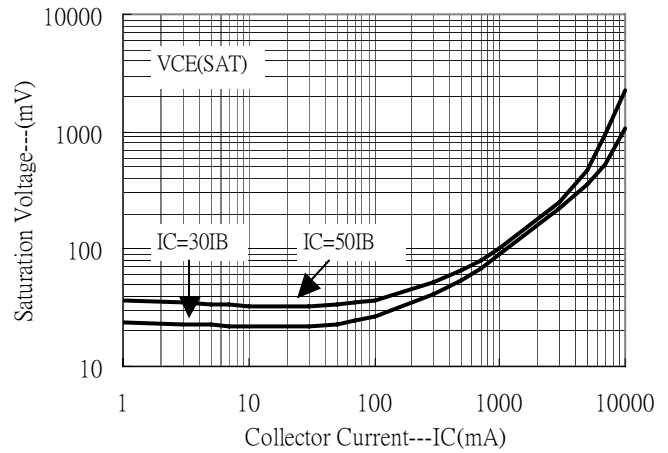

Saturation Voltage vs Collector Current

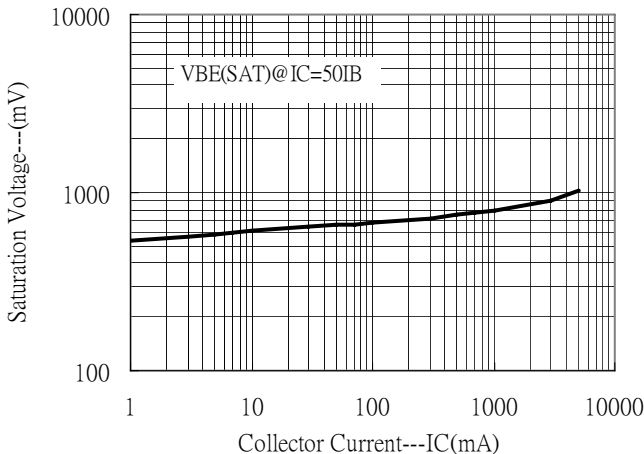

Grounded Emitter Output Characteristics

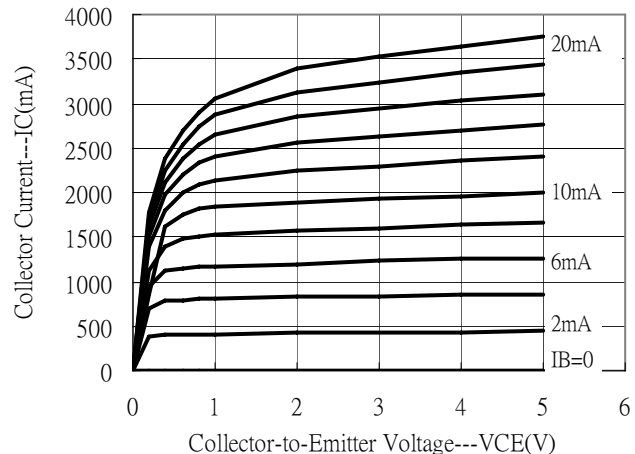



### Characteristic Curves(Cont.)

Grounded Emitter Output Characteristics

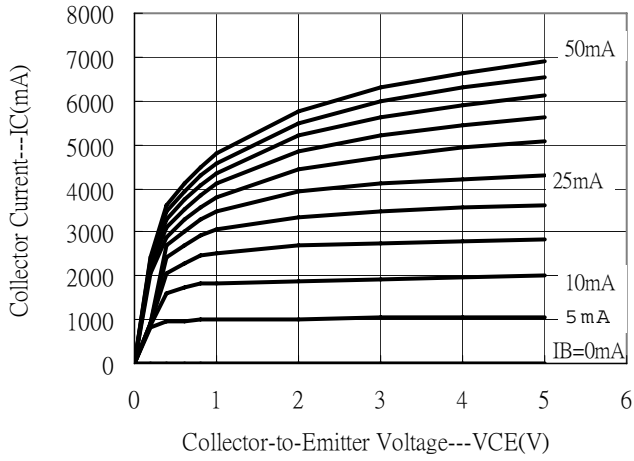

Power Derating Curve

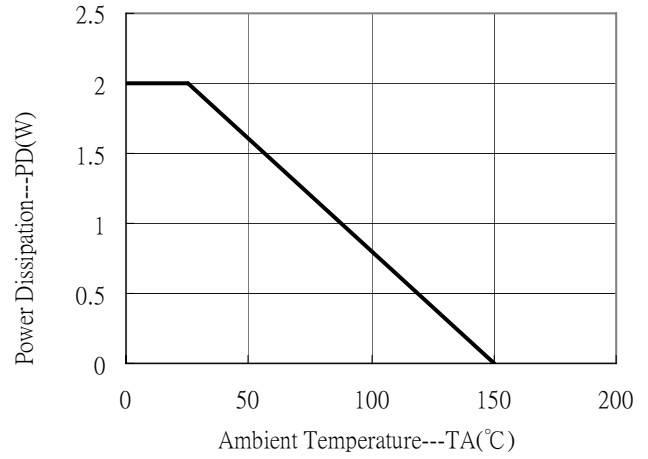

Power Derating Curve

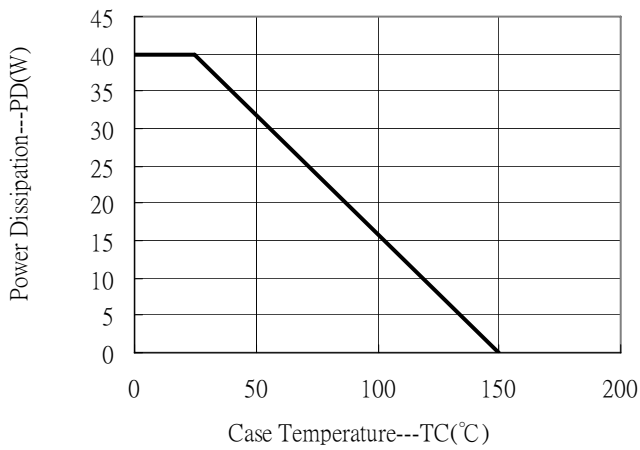

**TO-220FP Dimension**

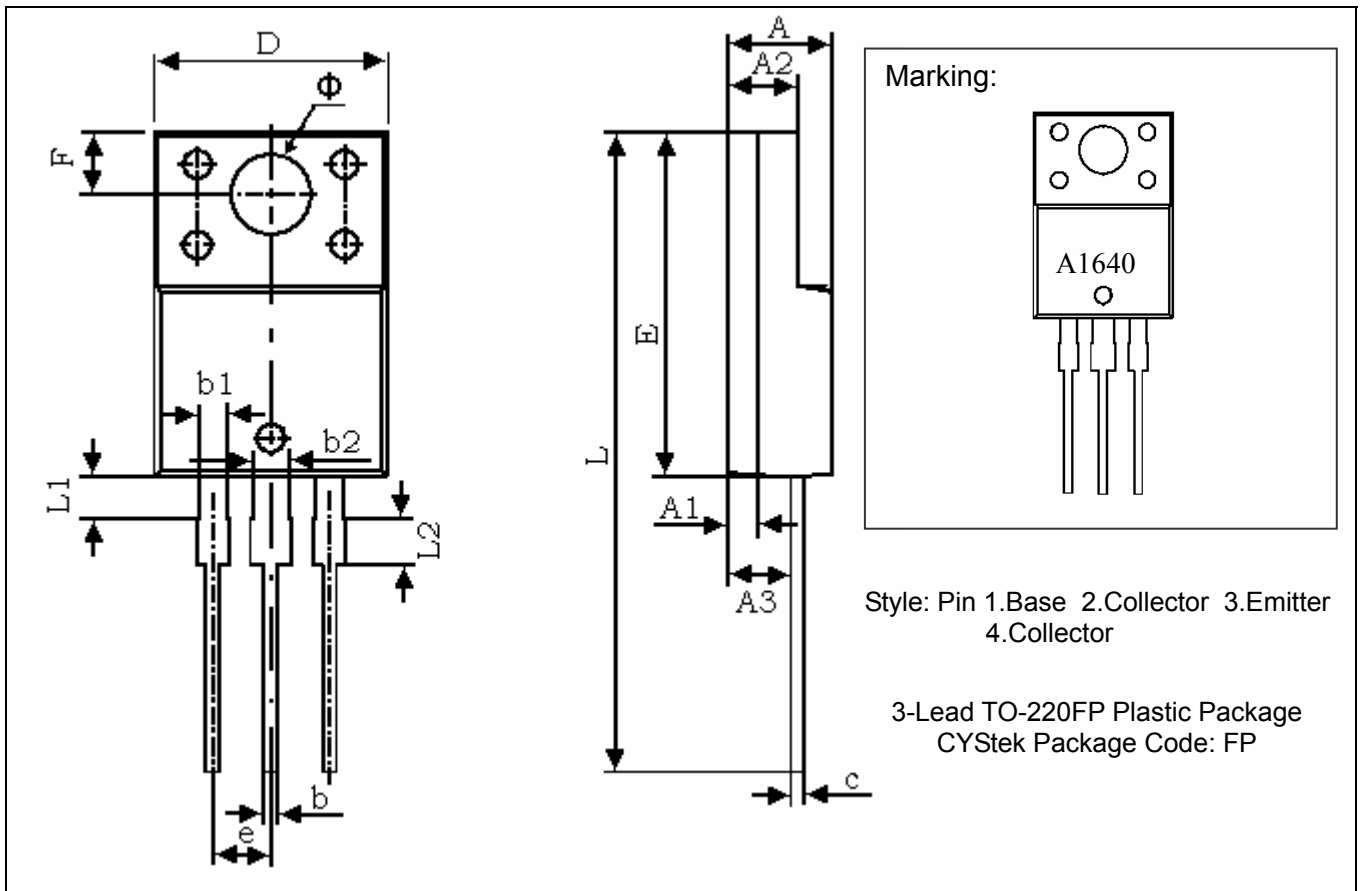

\*: Typical

DIM	Inches		Millimeters		DIM	Inches		Millimeters	
	Min.	Max.	Min.	Max.		Min.	Max.	Min.	Max.
A	0.169	0.185	4.300	4.700	D	0.392	0.408	9.960	10.360
A1	0.051 REF		1.300 REF		E	0.583	0.598	14.800	15.200
A2	0.110	0.126	2.800	3.200	e	0.100 TYP		2.540 TYP	
A3	0.098	0.114	2.500	2.900	F	0.106 REF		2.700 REF	
b	0.020	0.030	0.500	0.750	Φ	0.138 REF		3.500 REF	
b1	0.043	0.053	1.100	1.350	L	1.102	1.118	28.000	28.400
b2	0.059	0.069	1.500	1.750	L1	0.067	0.075	1.700	1.900
c	0.020	0.030	0.500	0.750	L2	0.075	0.083	1.900	2.100

- Notes:**
- 1.Controlling dimension: millimeters.
  - 2.Maximum lead thickness includes lead finish thickness, and minimum lead thickness is the minimum thickness of base material.
  - 3.If there is any question with packing specification or packing method, please contact your local CYStek sales office.

**Material:**

- Lead: 42 Alloy ; solder plating
- Mold Compound: Epoxy resin family, flammability solid burning class: UL94V-0

**Important Notice:**

- All rights are reserved. Reproduction in whole or in part is prohibited without the prior written approval of CYStek.
- CYStek reserves the right to make changes to its products without notice.
- CYStek **semiconductor products are not warranted to be suitable for use in Life-Support Applications, or systems.**
- CYStek assumes no liability for any consequence of customer product design, infringement of patents, or application assistance.