

# SHINDENGEN

## Super Fast Recovery Rectifiers

Modules

# D120LC40

## 400V 120A

### FEATURES

- High current capacity
- trr100ns
- Small  $\theta_{jc}$

### APPLICATION

- Semiconductor Production Equipment
- Big Power Supply
- Factory Automation, Robot

### OUTLINE DIMENSIONS

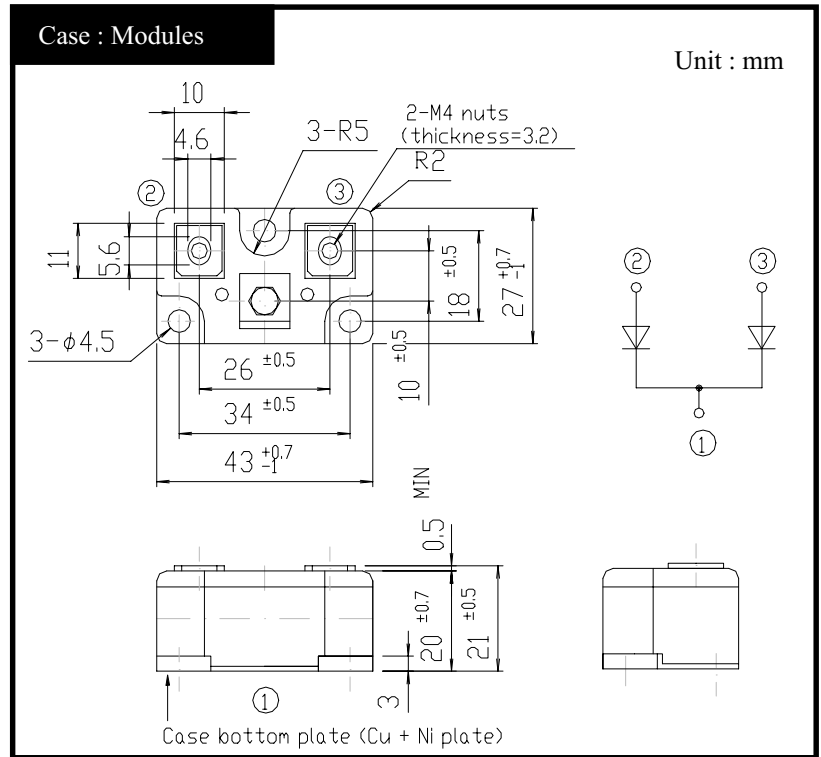

### RATINGS

#### ● Absolute Maximum Ratings (If not specified $T_c=25^\circ\text{C}$ )

Item	Symbol	Conditions	Ratings	Unit
Storage Temperature	$T_{stg}$		-40~150	$^\circ\text{C}$
Operating Junction Temperature	$T_j$		150	$^\circ\text{C}$
Maximum Reverse Voltage	$V_{RM}$		400	V
Average Rectified Forward Current	$I_O$	50Hz sine wave, R-load, Rating for each arm $I_o/2$ , $T_c=95^\circ\text{C}$	120	A
Peak Surge Forward Current	$I_{FSM}$	50Hz sine wave, Non-repetitive 1cycle peak value, Rating of per arm $T_j=25^\circ\text{C}$	650	A
Mounting Torque	TOR		1.7	N·m

#### ● Electrical Characteristics (If not specified $T_c=25^\circ\text{C}$ )

Item	Symbol	Conditions	Ratings	Unit
Forward Voltage	$V_F$	$I_F=60\text{A}$ , Pulse measurement, Rating of per arm	Max.1.3	V
Reverse Current	$I_R$	$V_R=V_{RM}$ , Pulse measurement, Rating of per arm	Max.25	$\mu\text{A}$
Reverse Recovery Time	trr	$I_F=0.5\text{A}$ , $I_R=1\text{A}$ , Rating of per arm	Max.100	ns
Thermal Resistance	$\theta_{jc}$	junction to case	Max.0.31	$^\circ\text{C}/\text{W}$

# D120LC40 Forward Voltage

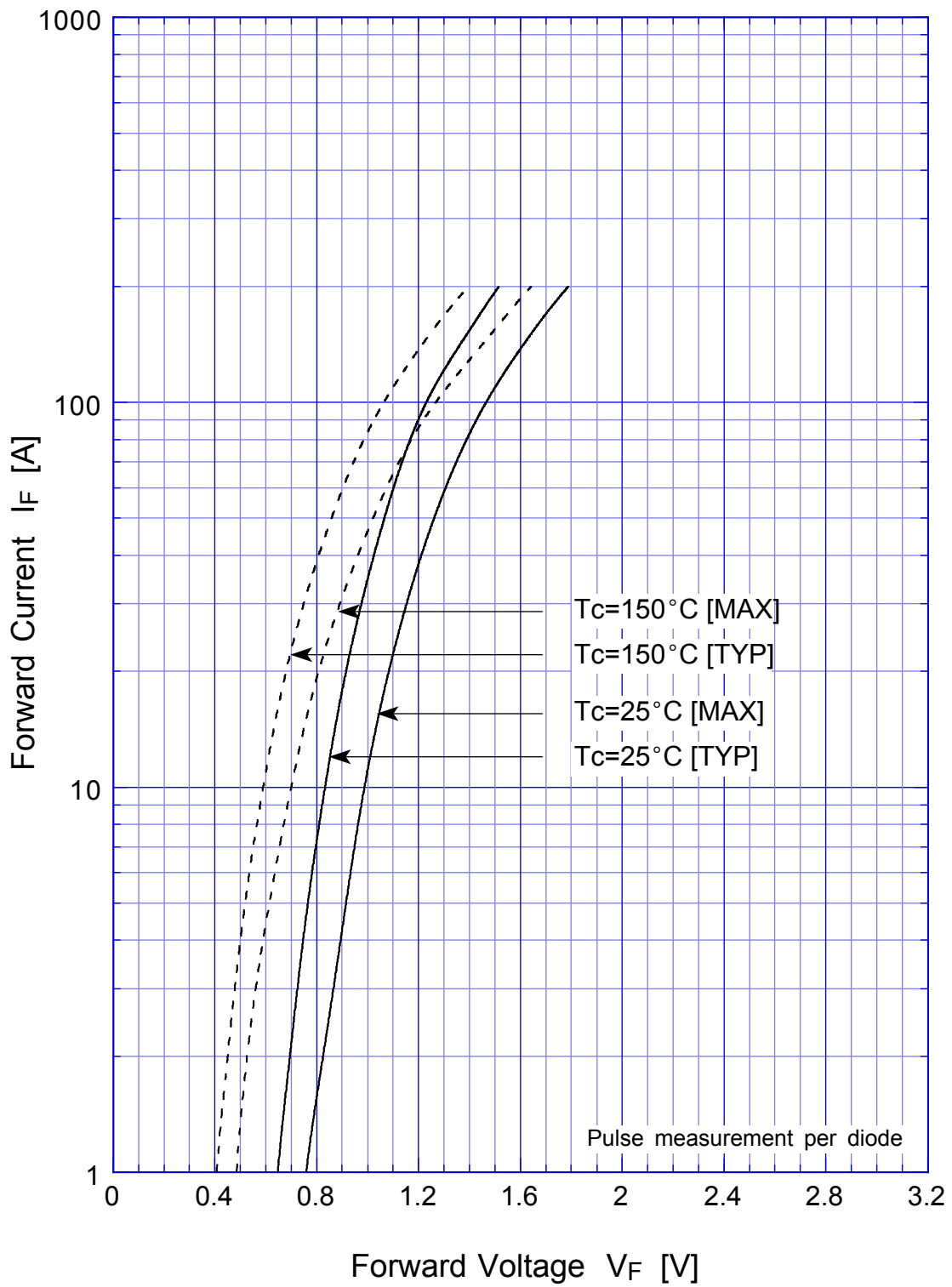

# D120LC40 Forward Power Dissipation

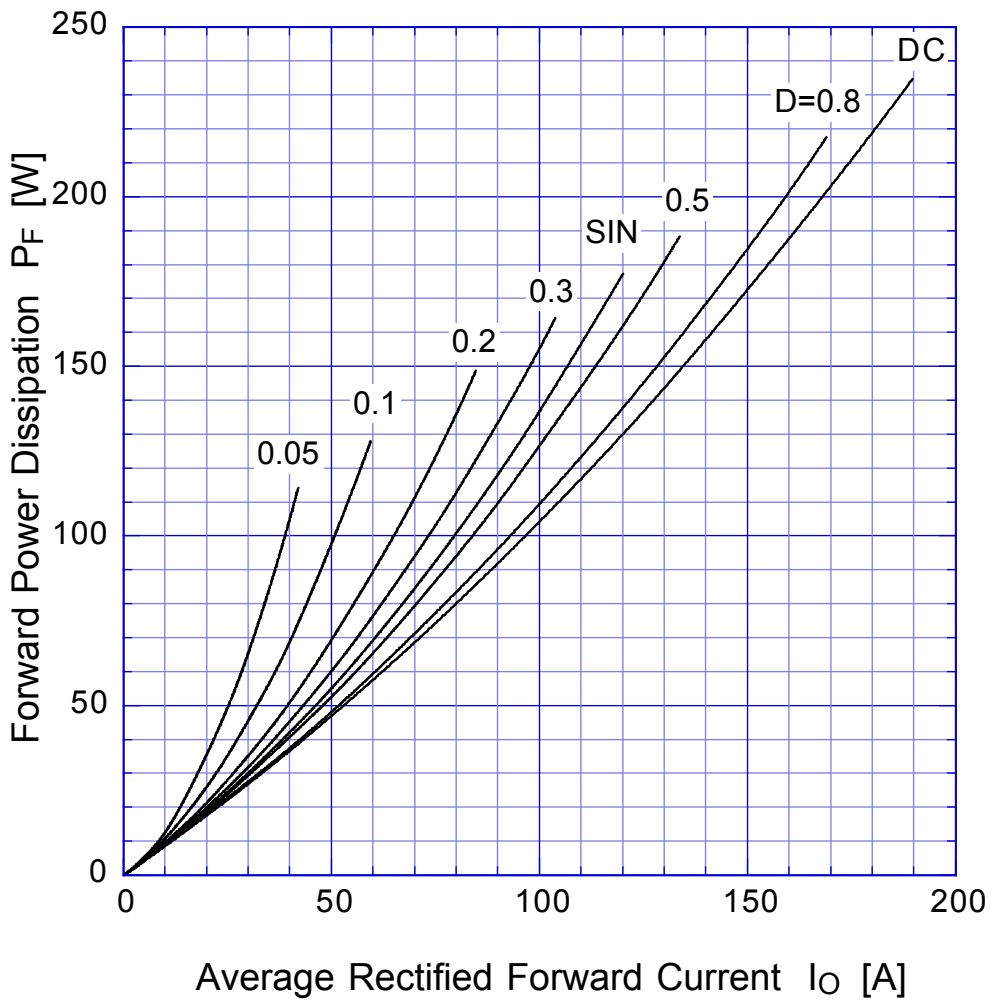

$T_j = T_{jmax}$

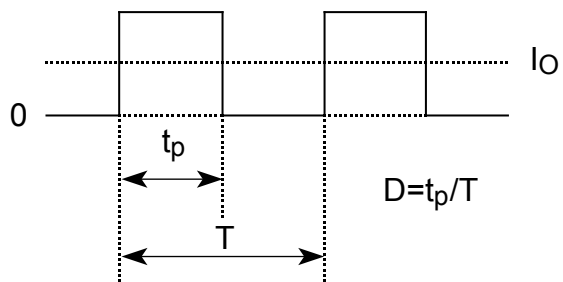

# D120LC40

## Derating Curve

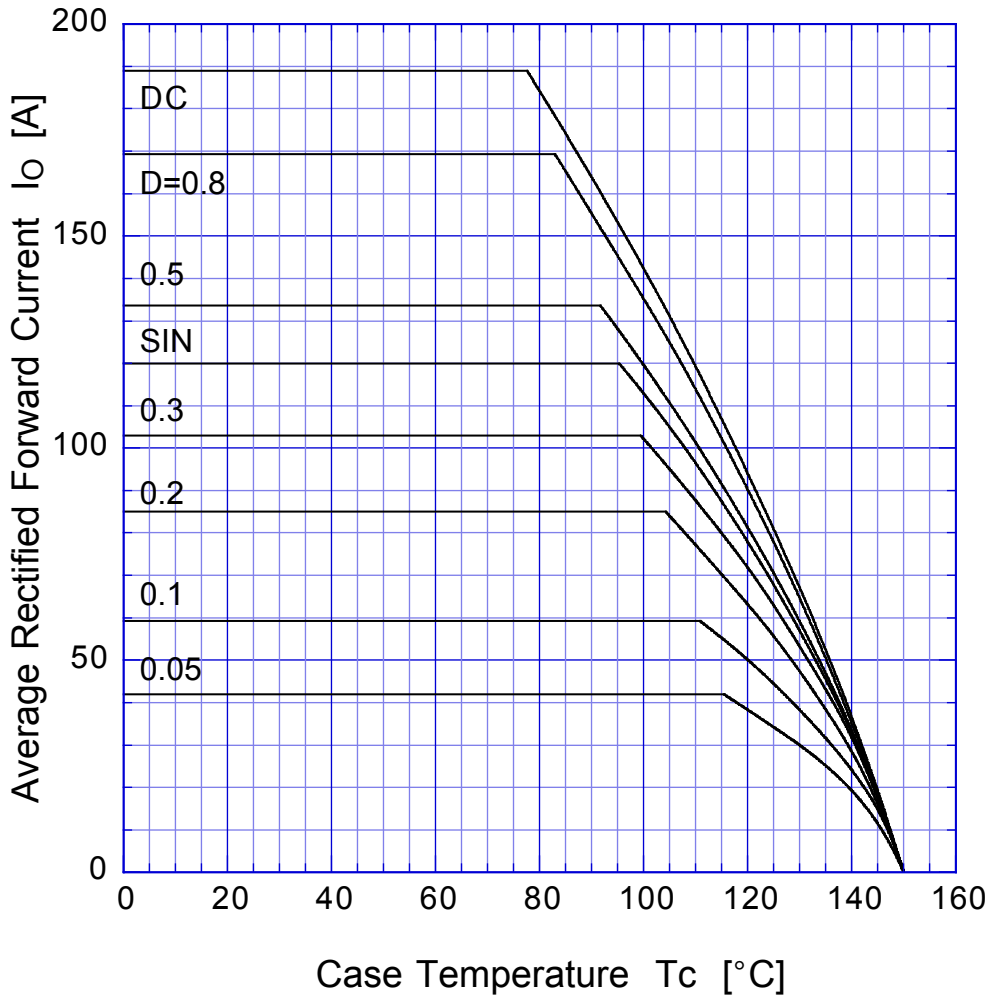

$$V_R = V_{RM}$$

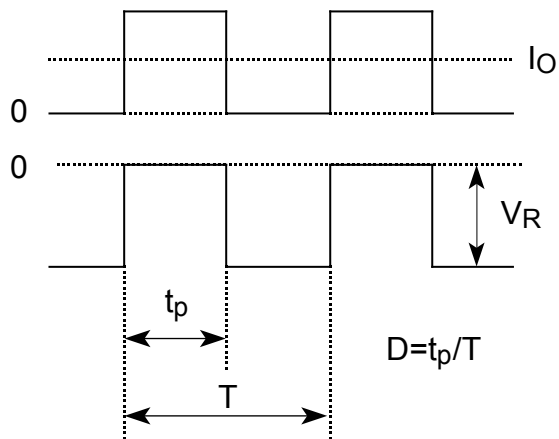

# D120LC40 Peak Surge Forward Capability

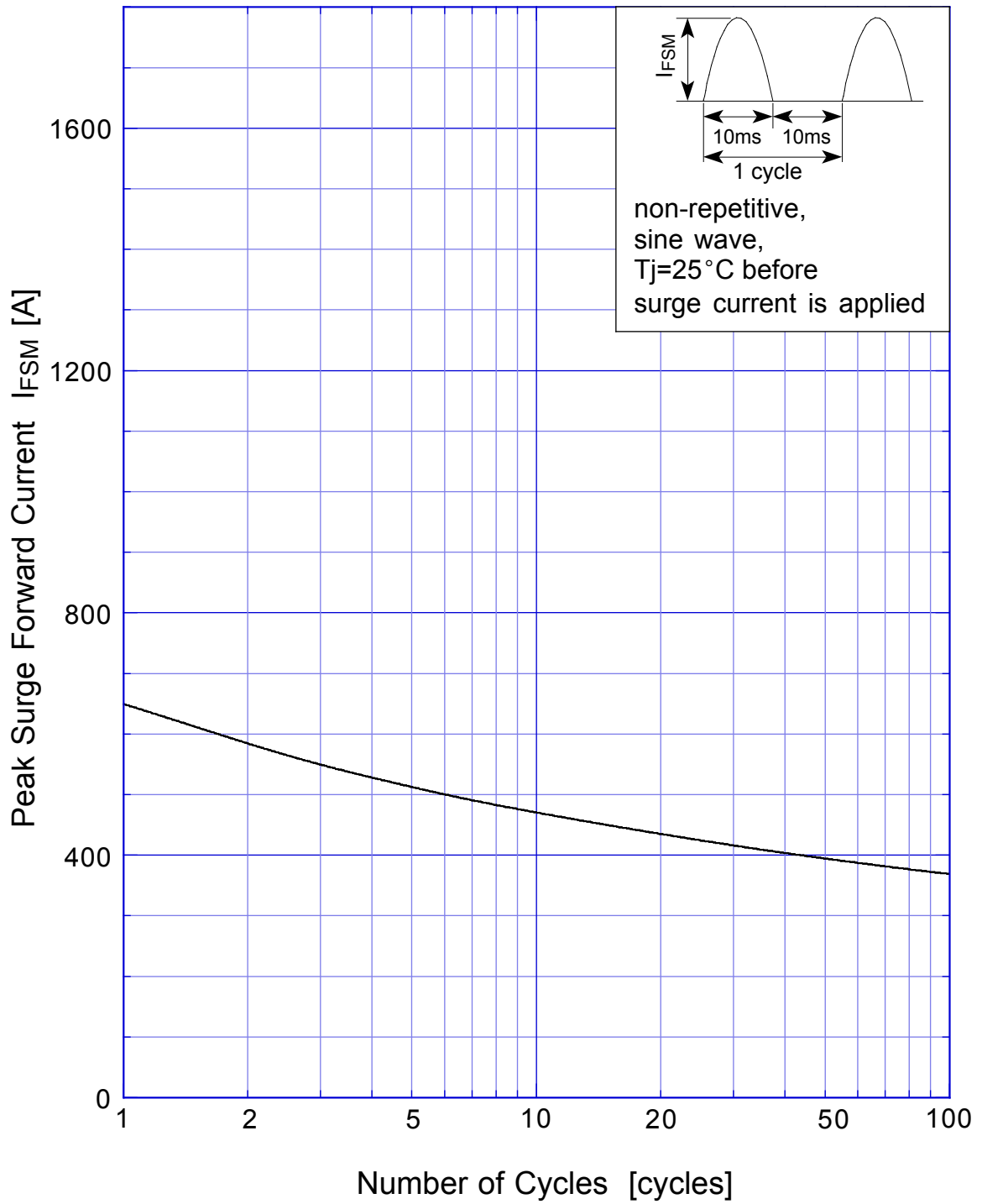

# D120LC40 Junction Capacitance

