

**PLEASE CHECK WWW.MOLEX.COM FOR LATEST PART INFORMATION**

**Part Number:** **0190020020**  
**Status:** **Active**  
**Description:** Avikrimp™ Fully Insulated Quick Disconnect, Female, for 18-22 AWG Wire, Mylar Tape

**Documents:**

[Drawing \(PDF\)](#) [RoHS Certificate of Compliance \(PDF\)](#)

**Agency Certification**

UL E79133

**General**

Product Family Quick Disconnects  
 Series 19002  
 Crimp Quality Equipment Yes  
 Product Name Avikrimp™  
 Type Quick Disconnect

**Physical**

Barrel Type Closed  
 Flammability 94V-2  
 Gender Female  
 Glow-Wire Compliant No  
 Insulation Nylon (PA)  
 Lock to Mating Part None  
 Material - Metal Brass  
 Orientation Straight  
 Packaging Type Adhesive Tape on Reel  
 Polarized to Mating Part No  
 Tab Thickness 0.51mm (.020")  
 Tab Width 5.21mm (.205")  
 Temperature Range - Operating -65°C to +105°C  
 Wire Insulation Diameter 3.17mm (.125") max.  
 Wire Size AWG 18, 20, 22  
 Wire Size mm² 0.35 - 0.80

**Electrical**

Voltage - Maximum 300V

**Material Info**

Old Part Number AA-5283T

**Reference - Drawing Numbers**

Sales Drawing SD-19002-003

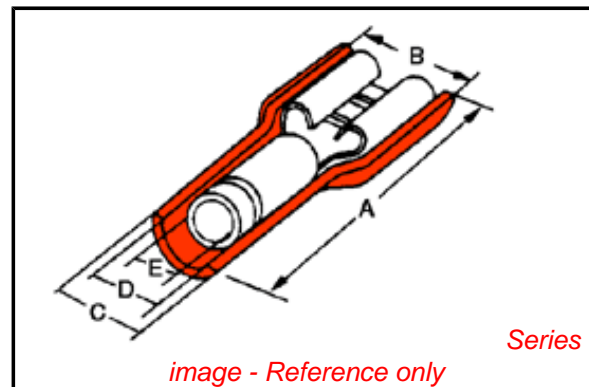

*image - Reference only*

**EU RoHS**

**ELV and RoHS Compliant**

**REACH SVHC**

Not Reviewed

**Halogen-Free**

**Status**

**Not Reviewed**

**China RoHS**



**Need more information on product environmental compliance?**

Email [productcompliance@molex.com](mailto:productcompliance@molex.com)  
 For a multiple part number RoHS Certificate of Compliance, [click here](#)

Please visit the [Contact Us](#) section for any non-product compliance questions.

**Search Parts in this Series**

19002Series

**Application Tooling | [FAQ](#)**

*Tooling specifications and manuals are found by selecting the products below. Crimp Height Specifications are then contained in the Application Tooling Specification document.*

**Global**

Description	Product #
ATP Perishable Tool Kit Used in ATP Presses that Process Product on Tape	<u>0192880028</u>
Mini-Mac™ Applicator	<u>0638852000</u>

13	12	11	10	9	8	7	6	5	4	3	2	1				
MATERIAL NUMBER LOOSE PCS	ENGINEERING NUMBER LOOSE PCS	MATERIAL NUMBER ON STRIP	ENGINEERING NUMBER ON STRIP	MATERIAL NUMBER ON TAPE	ENGINEERING NUMBER ON TAPE	MATERIAL NUMBER REV WOUND ON TAPE	ENGINEERING NUMBER REV WOUND ON TAPE	MATERIAL NUMBER ON TAPE BIG REEL	ENGINEERING NUMBER ON TAPE BIG REEL	ACCEPTS TAB SIZE	STOCK THK	"A" MAX	"B" MAX	"F" REF	"G" MAX	"H" REF
190020001	AA-5261	190020004	AA-5261Z	190020002	AA-5261T	190020003	AA-5261TR	190020047	AA-5261BT	.250 X .032	.016/0.41	.89/22.6	.38/9.7	.16/4.1	.20/5.1	1.425/36.20
190020019	AA-5283	190020059	AA-5283Z	190020020	AA-5283T	190020058	AA-5283TR			.205 X .020	.016/0.41	.80/20.3	.32/8.1	.16/4.1	.22/5.6	1.395/35.43
190020021	AA-5285	190020023	AA-5285Z	190020022	AA-5285T	190020060	AA-5285TR			.205 X .032	.016/0.41	.80/20.3	.32/8.1	.16/4.1	.22/5.6	1.395/35.43
190020005	AA-5267	190020008	AA-5267Z	190020007	AA-5267T			190020006	AA-5267BT	.187 X .020	.016/0.41	.80/20.3	.32/8.1	.16/4.1	.22/5.6	1.380/35.10
190020009	AA-5271	190020012	AA-5271Z	190020010	AA-5271T	190020011	AA-5271TR			.187 X .032	.016/0.41	.80/20.3	.32/8.1	.16/4.1	.22/5.6	1.380/35.10
190020013	AA-5275	190020015	AA-5275Z	190020014	AA-5275T					.110 X .020	.012/0.31	.80/20.3	.23/5.8	.13/3.3	.20/5.1	1.380/35.05
190020016	AA-5279	190020018	AA-5279Z	190020017	AA-5279T	190020065	AA-5279TR			.110 X .032	.012/0.31	.80/20.3	.23/5.8	.13/3.3	.20/5.1	1.380/35.05

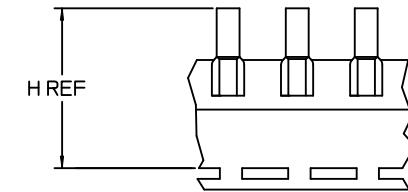
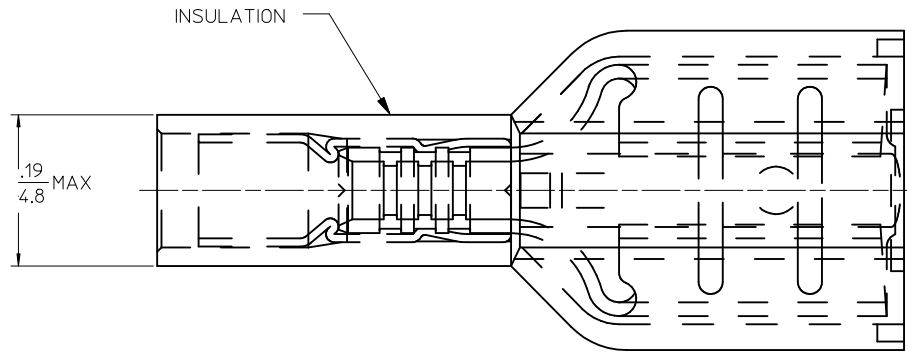

PARTS ON TAPE

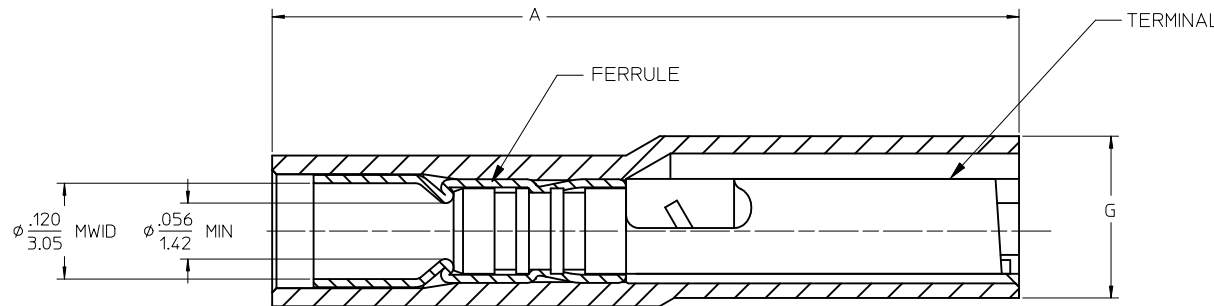

TERMINAL IS NOT SECTIONED FOR CLARITY

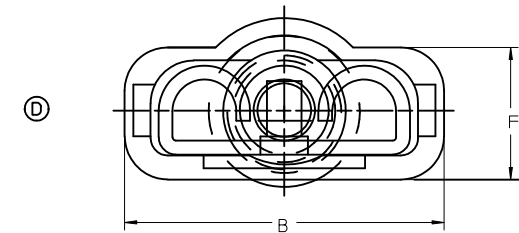

SALES DRAWING

NOTES:

- MATERIAL: TERMINAL BRASS  
TERMINAL PLATING: ELECTRO TIN  
① FERRULE: COPPER ALLOY  
FERRULE PLATING: ELECTRO TIN  
INSULATION: NYLON 94V2 COLOR RED.
- MWD = MAXIMUM WIRE INSULATION DIAMETER
- ① PARTS ARE ROHS COMPLIANT.

<b>FERRULE MAT'L DESCR</b> EC NO: MNA2009-0510 DRAWN: THRODAHL 2010/01/04 CHKD: JMACNEIL 2010/01/05 APPR: JMACNEIL 2010/01/05	QUALITY SYMBOLS ▽=0 ▽=0	GENERAL TOLERANCES (UNLESS SPECIFIED)		DIMENSION STYLE	SCALE	DESIGN UNITS	THIRD ANGLE PROJECTION		
				IN/MM	---	INCH			
				mm	INCH	DRAWN BY DATE		TITLE	
				4 PLACES ± ---	± ---	BENDERLE 2005/03/28		AVIKRIMP FEMALE FIQD 22-18 AWG	
REV D	DESCRIPTION			CHECKED BY DATE		MOLEX INCORPORATED			
				R DEROSS 2005/03/28		DOCUMENT NO.			
				APPROVED BY DATE		SD-19002-003			
				R DEROSS 2005/03/28		SHEET NO.			
		ANGULAR ± ---°		MATERIAL NO.		1 OF 1			
		DRAFT WHERE APPLICABLE MUST REMAIN WITHIN DIMENSIONS		SEE CHART		THIS DRAWING CONTAINS INFORMATION THAT IS PROPRIETARY TO MOLEX INCORPORATED AND SHOULD NOT BE USED WITHOUT WRITTEN PERMISSION			