

Phase-sequence Phase-loss Relay K8AB-PH

CSM_K8AB-PH_DS_E_2_1

Three-phase Phase-sequence Phase-loss Relay Using Voltage Detection Method

- Prevents reverse motor rotation due to incorrect wiring.
- Distinguishes between positive phases, reversed phases, and phase loss when power is turned ON.
- Voltage detection method enables application for any load current.
- One SPDT output relay, 6 A at 250 VAC (resistive load).
- Output status can be monitored using LED indicator.



Refer to *Safety Precautions for the K8AB Series*. Refer to page 5 for the Q&A section.



Model Number Structure

Model Number Legend

K8AB-□□
1 2 3

1. Basic Model

K8AB: Measuring and Monitoring Relays

2. Functions

PH: Phase-sequence Phase-loss Relay

3. Rated Input Voltage

1: 200 to 500 VAC

Ordering Information

List of Models

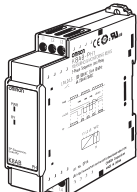
Phase-sequence Phase-loss Relay	Functions	Rated input voltage (See note.)	Model
	Phase sequence and phase loss monitoring	200 to 500 VAC	K8AB-PH1

Note: The power supply is shared with the rated input voltage.

Ratings and Specifications

■ Ratings

Rated input voltage	Three-phase, three-wire mode, 200 to 500 VAC
Input load	15 VA max.
Reversed phase and phase loss operating time	0.1 s max.
Reset method	Automatic reset
Indicators	Power (PWR): Green, Relay output (RY): Yellow
Output relays	One SPDT relay (NC operation)
Output relay ratings	<p>Rated load</p> <p>Resistive load</p> <p>6 A at 250 VAC ($\cos\phi = 1$)</p> <p>6 A at 30 VDC (L/R = 0 ms)</p> <p>Inductive load</p> <p>1 A at 250 VAC ($\cos\phi = 0.4$)</p> <p>1 A at 30 VDC (L/R = 7 ms)</p> <p>Maximum contact voltage: 250 VAC</p> <p>Maximum contact current: 6 A AC</p> <p>Maximum switching capacity: 1,500 VA</p> <p>Minimum load: 10 mA at 5 VDC</p> <p>Mechanical life: 10,000,000 operations</p> <p>Electrical life: Make: 50,000 times, Break: 30,000 times</p>
Ambient operating temperature	-20 to 60°C (with no condensation or icing)
Storage temperature	-40 to 70°C (with no condensation or icing)
Ambient operating humidity	25% to 85% (with no condensation)
Storage humidity	25% to 85% (with no condensation)
Altitude	2,000 m max.
Terminal screw tightening torque	0.49 N·m
Terminal wiring method	<p>Recommended wire</p> <p>Solid wire: 2.5 mm²</p> <p>Twisted wires: AWG16, AWG18</p> <p>Note: 1. Ferrules with insulating sleeves must be used with twisted wires. 2. Two wires can be twisted together.</p> <p>Recommended ferrules</p> <p>Al 1,5-8BK (for AWG16) manufactured by Phoenix Contact</p> <p>Al 1-8RD (for AWG18) manufactured by Phoenix Contact</p> <p>Al 0,75-8GY (for AWG18) manufactured by Phoenix Contact</p>
Case color	Munsell 5Y8/1
Case material	ABS resin (self-extinguishing resin) UL94-V0
Weight	Approx. 110 g
Mounting	Mounted to DIN Track or via M4 screws (tightening torque: 1.2 N·m)
Dimensions	22.5 (W) × 90 (H) × 100 (D) mm

Specifications

Input voltage range		200 to 500 VAC
Input frequency range		45 to 65 Hz
Overload capacity		Continuous input: 115% of maximum input, 10 s max.: 125% of maximum input
Temperature influence		Operating time Fluctuation based on measured value at standard temperature: -20°C to standard temperature: ±10% max. Standard temperature to 60°C : ±10% max. (Humidity: 25% to 80%)
Humidity influence		Operating time Based on ambient room humidity 25% to 80%: ±10% max.
Influence of power supply voltage		Operating time: ±10% max. Note: The error in the operating value and operating time under standard conditions.
Influence of power supply frequency		Operating time: ±10% max. (at 45 to 65 Hz) Note: The error in the operating value and operating time under standard conditions.
Influence of input frequency		At 45 to 65 Hz Operating time ±10% max. Note: The error in the operating value and operating time under standard conditions.
Applicable standards	Conforming standards	EN60255-5 and EN60255-6 Installation environment (Pollution Degree 2, Overvoltage Category III)
	EMC	EN61326
	Safety standards	UL508
Insulation resistance		20 MΩ min. Between external terminals and case Between input terminals and output terminals
Dielectric strength		2,000 VAC for one minute Between external terminals and case Between input terminals and output terminals
Noise immunity		1,500 V power supply terminal common/normal mode Square-wave noise of ±1 μs/100 ns pulse width with 1-ns rise time
Vibration resistance		Frequency 10 to 55 Hz, 0.35-mm single amplitude, acceleration 50 m/s ² 10 sweeps of 5 min each in X, Y, and Z directions
Shock resistance		100 m/s ² , 3 times each in 6 directions along three axes (up/down, left/right, forward/backward)
Degree of protection		Terminal section: Finger protection

Connections

Wiring Diagram

Phase Sequence and Phase Loss Operation Diagram



- Note:**
1. Motor load phase loss cannot be detected. To detect motor load phase loss, use the K8AB-PM or K8AB-PA.
 2. The K8AB-PH output relay is normally operative.
 3. L1 and L3 function both as the power supply terminals and as input terminals. If the voltage drops below the minimum input voltage (60%), then the Relay will not operate due to an undervoltage.
 4. Phase loss is detected based on the phase sequence, so phase loss cannot be detected for loads that generate inductive power, e.g., due to motor during operation.
 5. Phase loss is detected based on voltage, so phase loss cannot be detected on the load side.

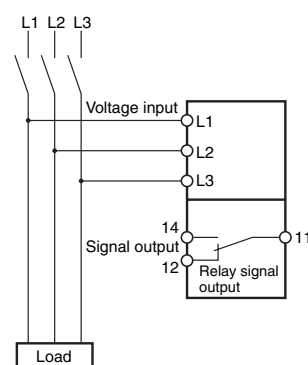

Nomenclature

■ Front

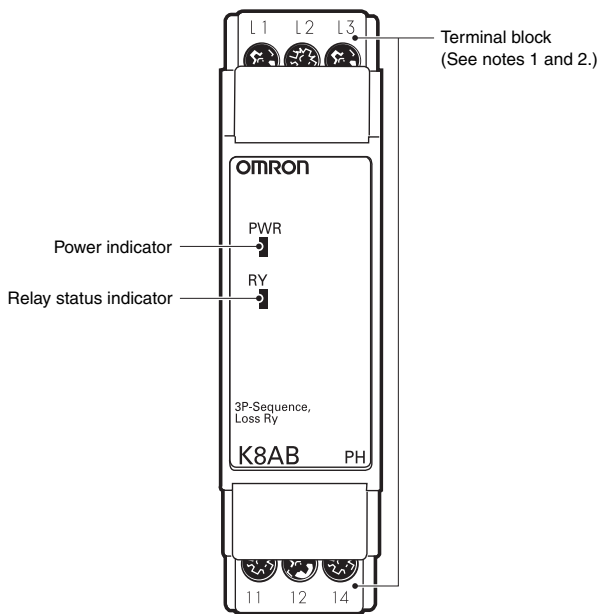

Indicators

Item	Meaning
Power indicator (PWR: Green)	Lit when power is being supplied (see note).
Relay status indicator (RY: Yellow)	Lit when relay is operating (normally lit).

- Note: 1.** The input across L1 and L3 is used for the internal power supply. Therefore, the power indicator will not be lit if there is no input across L1 and L3.
- 2.** Use either a solid wire of 2.5 mm² maximum or a ferrule with insulating sleeve for the terminal connection. The length of the exposed current-carrying part inserted into the terminal must be 8 mm or less to maintain dielectric strength after connection.

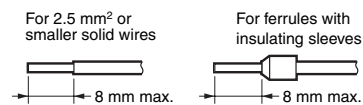

Recommended ferrules

- Phoenix Contact
- AI 1,5-8BK (for AWG16)
 - AI 1-8RD (for AWG18)
 - AI 0,75-8GY (for AWG18)

- 3.** Tightening torque
 Recommended: 0.49 N·m
 Maximum: 0.54 N·m

■ Operation and Setting Methods

Connections

- 1. Input**
 Connect using L1, L2, and L3.
 Make sure the phase sequence is wired correctly. The Unit will not operate normally if the phase sequence is incorrect.
- 2. Outputs**
 Terminals 11, 12, and 14 are output terminals for SPDT.

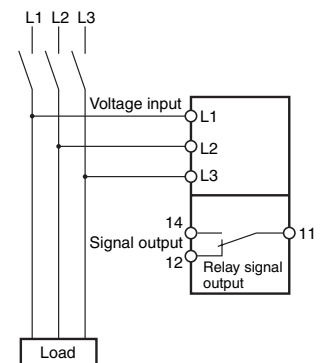

Dimensions

(Unit: mm)

Phase-sequence, Phase-loss Relays

K8AB-PH1

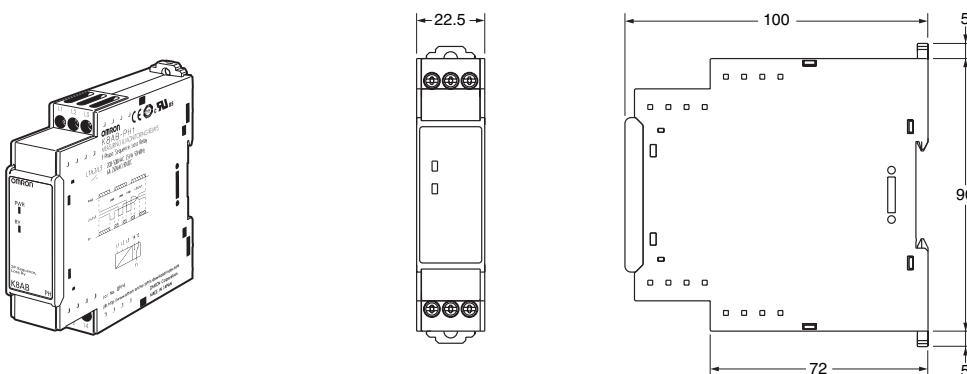

Questions and Answers

Q Checking Operation

A Phase Sequence
Switch the wiring, as shown by the dotted lines in the connection diagram, to reverse the phase sequence and check that the K8AB operates.

Phase Loss
Create a phase loss for any input phase and check that the K8AB operates.

Connection Diagram

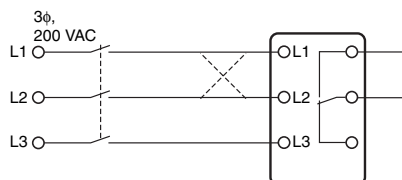

Q Can phase loss be detected on the load side?

A In principle, phase loss cannot be detected on the load side because the K8AB-PH1 measures three-phase voltage to determine phase loss.

Q Motor Load Phase Loss during Operation

A Motor load phase loss cannot be detected during operation. It can be used to detect phase loss at startup. Normally, three-phase motors will continue to rotate even if one phase is open. The three-phase voltage will be induced at the motor terminals. The diagram shows voltage induction at the motor terminals when phase R has been lost with a load applied to a three-phase motor. The horizontal axis shows the motor load as a percentage of the rated load, and the vertical axis shows voltage as a percentage of the rated voltage. The lines in the graph show the voltage induced at the motor terminals for each load when phase loss occurs during operation. As the graph shows, voltage is induced at the motor terminals even if there is phase loss for a motor load, so the K8AB-PH1 cannot detect phase loss for motor loads during operation. Use the K8AB-PH1 to detect phase loss at startup.

Characteristic Curve Diagram

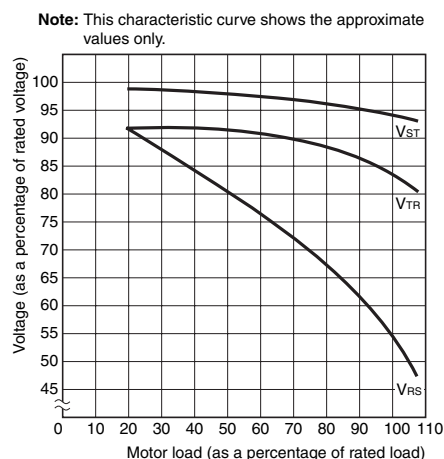

Note: For phase loss of phase R. V_{st}, V_{tr}, and V_{rs} indicate the motor terminal voltage at phase loss.

ALL DIMENSIONS SHOWN ARE IN MILLIMETERS.
To convert millimeters into inches, multiply by 0.03937. To convert grams into ounces, multiply by 0.03527.

In the interest of product improvement, specifications are subject to change without notice.

Read and Understand This Catalog

Please read and understand this catalog before purchasing the products. Please consult your OMRON representative if you have any questions or comments.

Warranty and Limitations of Liability

WARRANTY

OMRON's exclusive warranty is that the products are free from defects in materials and workmanship for a period of one year (or other period if specified) from date of sale by OMRON.

OMRON MAKES NO WARRANTY OR REPRESENTATION, EXPRESS OR IMPLIED, REGARDING NON-INFRINGEMENT, MERCHANTABILITY, OR FITNESS FOR PARTICULAR PURPOSE OF THE PRODUCTS. ANY BUYER OR USER ACKNOWLEDGES THAT THE BUYER OR USER ALONE HAS DETERMINED THAT THE PRODUCTS WILL SUITABLY MEET THE REQUIREMENTS OF THEIR INTENDED USE. OMRON DISCLAIMS ALL OTHER WARRANTIES, EXPRESS OR IMPLIED.

LIMITATIONS OF LIABILITY

OMRON SHALL NOT BE RESPONSIBLE FOR SPECIAL, INDIRECT, OR CONSEQUENTIAL DAMAGES, LOSS OF PROFITS OR COMMERCIAL LOSS IN ANY WAY CONNECTED WITH THE PRODUCTS, WHETHER SUCH CLAIM IS BASED ON CONTRACT, WARRANTY, NEGLIGENCE, OR STRICT LIABILITY.

In no event shall the responsibility of OMRON for any act exceed the individual price of the product on which liability is asserted.

IN NO EVENT SHALL OMRON BE RESPONSIBLE FOR WARRANTY, REPAIR, OR OTHER CLAIMS REGARDING THE PRODUCTS UNLESS OMRON'S ANALYSIS CONFIRMS THAT THE PRODUCTS WERE PROPERLY HANDLED, STORED, INSTALLED, AND MAINTAINED AND NOT SUBJECT TO CONTAMINATION, ABUSE, MISUSE, OR INAPPROPRIATE MODIFICATION OR REPAIR.

Application Considerations

SUITABILITY FOR USE

OMRON shall not be responsible for conformity with any standards, codes, or regulations that apply to the combination of products in the customer's application or use of the products.

At the customer's request, OMRON will provide applicable third party certification documents identifying ratings and limitations of use that apply to the products. This information by itself is not sufficient for a complete determination of the suitability of the products in combination with the end product, machine, system, or other application or use.

The following are some examples of applications for which particular attention must be given. This is not intended to be an exhaustive list of all possible uses of the products, nor is it intended to imply that the uses listed may be suitable for the products:

- Outdoor use, uses involving potential chemical contamination or electrical interference, or conditions or uses not described in this catalog.
- Nuclear energy control systems, combustion systems, railroad systems, aviation systems, medical equipment, amusement machines, vehicles, safety equipment, and installations subject to separate industry or government regulations.
- Systems, machines, and equipment that could present a risk to life or property.

Please know and observe all prohibitions of use applicable to the products.

NEVER USE THE PRODUCTS FOR AN APPLICATION INVOLVING SERIOUS RISK TO LIFE OR PROPERTY WITHOUT ENSURING THAT THE SYSTEM AS A WHOLE HAS BEEN DESIGNED TO ADDRESS THE RISKS, AND THAT THE OMRON PRODUCTS ARE PROPERLY RATED AND INSTALLED FOR THE INTENDED USE WITHIN THE OVERALL EQUIPMENT OR SYSTEM.

PROGRAMMABLE PRODUCTS

OMRON shall not be responsible for the user's programming of a programmable product, or any consequence thereof.

Disclaimers

CHANGE IN SPECIFICATIONS

Product specifications and accessories may be changed at any time based on improvements and other reasons.

It is our practice to change model numbers when published ratings or features are changed, or when significant construction changes are made. However, some specifications of the products may be changed without any notice. When in doubt, special model numbers may be assigned to fix or establish key specifications for your application on your request. Please consult with your OMRON representative at any time to confirm actual specifications of purchased products.

DIMENSIONS AND WEIGHTS

Dimensions and weights are nominal and are not to be used for manufacturing purposes, even when tolerances are shown.

PERFORMANCE DATA

Performance data given in this catalog is provided as a guide for the user in determining suitability and does not constitute a warranty. It may represent the result of OMRON's test conditions, and the users must correlate it to actual application requirements. Actual performance is subject to the OMRON Warranty and Limitations of Liability.

ERRORS AND OMISSIONS

The information in this document has been carefully checked and is believed to be accurate; however, no responsibility is assumed for clerical, typographical, or proofreading errors, or omissions.

2009.10

In the interest of product improvement, specifications are subject to change without notice.

OMRON Corporation
Industrial Automation Company

<http://www.ia.omron.com/>

(c)Copyright OMRON Corporation 2009 All Right Reserved.